

Serial-Data Interface Chip Supplies Bipolar Voltages

Some of the interface ICs currently available for serial-data transmission not only operate from low VCC levels (5V or 3.3V); they also generate bipolar dc voltages ($\pm 6.5\text{V}$ to $\pm 10\text{V}$) to support the minimum driver-output levels as specified by E1a/T1a-232. With care, you can steal useful amounts of power from these voltage rails without interfering with the IC's operation.

In **Figure 1**, the IC's switch-mode controller operates with an external inductor, two diodes, and two capacitors to produce $\pm 6.5\text{V}$. FETs Q1 and Q2 ensure start-up for the circuit by disconnecting the load until these switch-mode supply voltages are present. Note that Q1 must be a logic-level device.

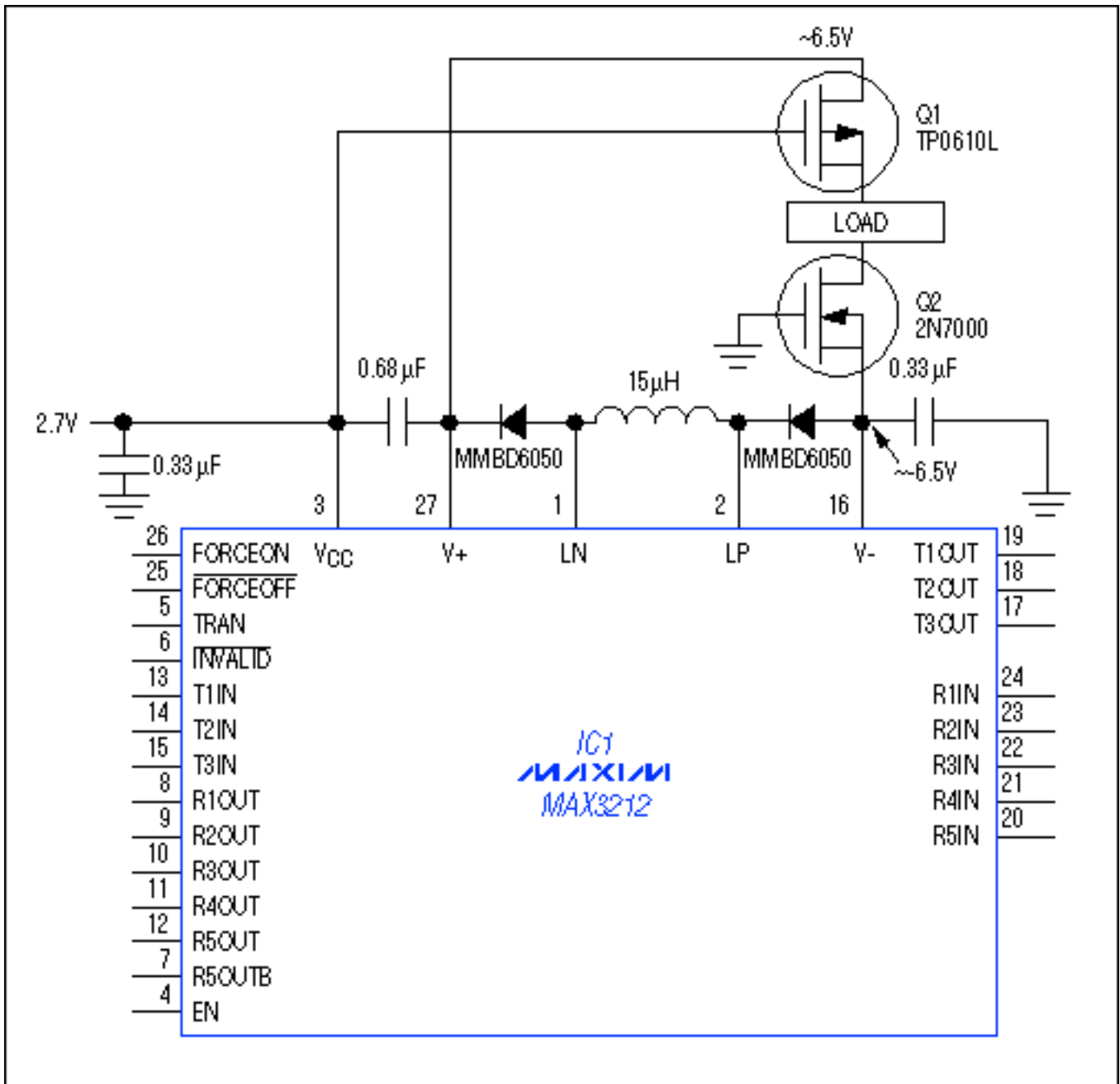

Figure 1. For data rates and driver-output loads less than the maximum allowed, the V+ and V- outputs of this serial interface IC can supply modest amounts of current to an external circuit.

Unlike ICs designed to generate supply voltages, an interface IC generally doesn't specify how much current you can draw from its internally generated supply rails. The amount available depends almost entirely on loads connected to the driver outputs. IC1, for example, guarantees that one transmitter can drive a parallel combination of 3k Ω and 1000pF at 250kbps while the other two maintain dc outputs across 3k Ω loads. These conditions let you calculate the chip's maximum output current capability, but you can't expect to draw extra current while delivering that maximum.

To calculate the maximum output current available, superimpose the ac and dc components: Output current flows alternately from each rail as the NRZ output waveform swings between

the guaranteed minimum output levels ($\pm 5V$). assuming the output requires one whole data period (4as at 250kbps) to slew from -5V to +5V, the ac component equals $CLOaD(dv/dt) = 1000pF(10V/4as) = 2.5ma$. For the dc component, Ohm's Law gives $I = E/R = 5V/3k\Omega = 1.67ma$ from one transmitter, so the three transmitters together represent a dc load of 5ma. adding the ac and dc components together gives a conservative maximum rating of $2.5ma + 5ma = 7.5ma$.

The $3k\Omega$ load is an E1a-232 requirement, but the data rate and load capacitance are application-dependent parameters. Lower values for these parameters make more current available for external use. a remote-sensing system, for instance, might operate at 2400 bits/sec (2400bps) with a load of $3k\Omega$ in parallel with 1000pF (50 feet of cable at 20pF/ft). The dc load for three transmitters is 5ma, and the ac load for one transmitter (72 μA) is almost negligible in this low-data-rate application. So, the available current in this case is calculated as $7.5ma - (5ma + 72\mu A) = 2.428ma$.

The above calculation is conservative: with $VCC = 2.7V$ and the three transmitters loaded with $3k\Omega || 1000pF$, a circuit transmitting valid E1a-232 levels at 2400bps will actually deliver 6.7ma to an external load (even more for $VCC = 3V$ and up). as mentioned, Q1 and Q2 enable the circuit to start under these conditions. If you disconnect the transmitter loads, the maximum external load current that allows start-up is 11.5ma. With Q1 and Q2 removed, the maximum is only 5.7ma.

More Information

MAX3212: [QuickView](#) -- [Full \(PDF\) Data Sheet](#) -- [Free Samples](#)