

# HA1630Q01/02/03 Series

## Low Voltage Operation CMOS Quad Operational Amplifier

REJ03D0802-0100

Rev.1.00

Mar 10, 2006

### Description

The HA1630Q01/02/03 are dual CMOS Operational Amplifiers realizing low voltage operation, low input offset voltage and low supply current. In addition to a low operating voltage from 1.8V, these device output can achieve full swing output voltage capability extending to either supply. Available in an ultra-small TSSOP-14 package that occupies only 1/2 the area of the SOP-14 package.

### Features

- Low power and single supply operation  $V_{DD} = 1.8$  to  $5.5$  V
- Low input offset voltage  $V_{IO} = 4.0$  mV Max
- Low supply current (per channel)
  - $I_{DD} = 15$   $\mu$ A Typ (HA1630Q01)
  - $I_{DD} = 50$   $\mu$ A Typ (HA1630Q02)
  - $I_{DD} = 100$   $\mu$ A Typ (HA1630Q03)
- Maximum output voltage  $V_{OH} = 2.9$  V Min (at  $V_{DD} = 3.0$  V)
- Low input bias current  $I_{IB} = 1$  pA Typ

### Ordering Information

Type No.	Package Name	Package Code
HA1630Q01T	TTP-14D	PTSP0014JA-B
HA1630Q02T	TTP-14D	PTSP0014JA-B
HA1630Q03T	TTP-14D	PTSP0014JA-B

## Pin Arrangement

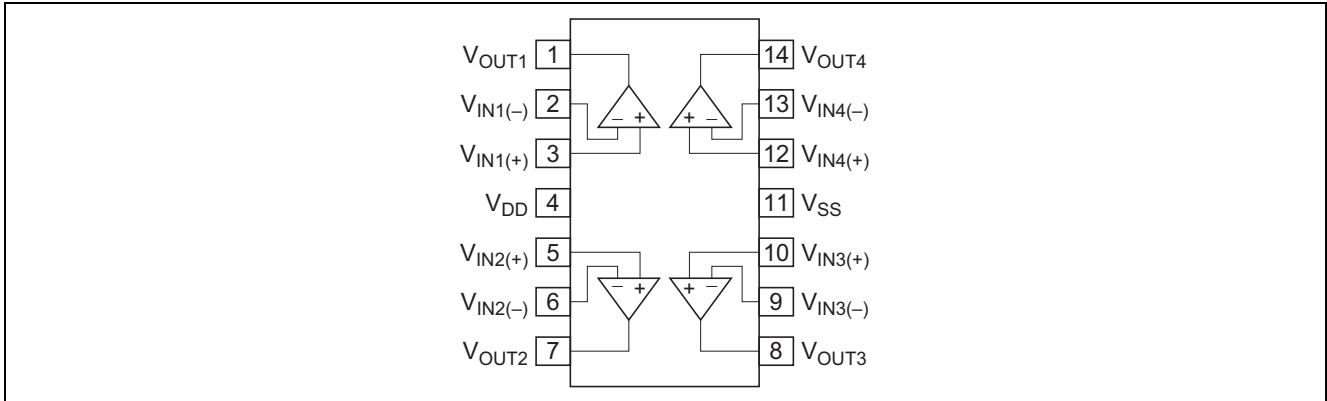

## Equivalent Circuit (per one channel)

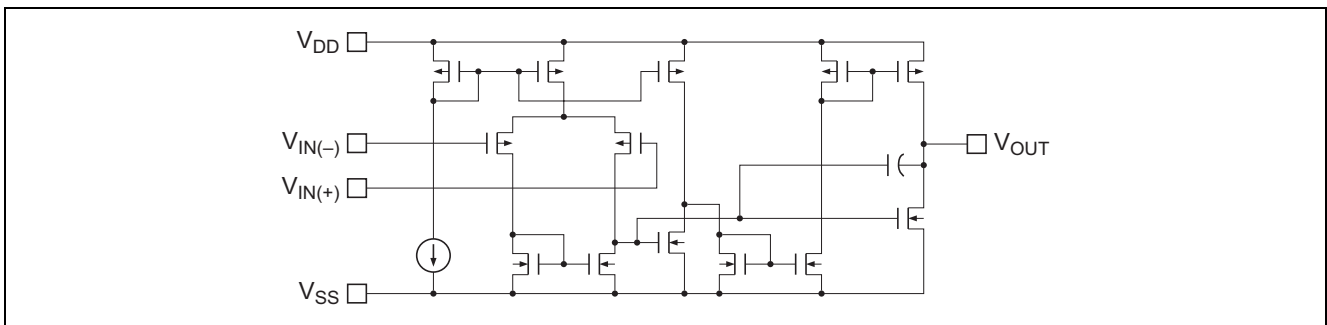

## Absolute Maximum Ratings

(Ta = 25°C)

Items	Symbol	Ratings	Unit	Note
Supply voltage	V <sub>DD</sub>	7	V	
Differential input voltage	V <sub>IN(diff)</sub>	-V <sub>DD</sub> to +V <sub>DD</sub>	V	
Input voltage	V <sub>IN</sub>	-0.3 to +V <sub>DD</sub>	V	1
Power dissipation	P <sub>T</sub>	400	mW	
Operating temp. Range	Topr	-40 to +85	°C	
Storage temp. Range	Tstg	-55 to +125	°C	

Note: 1. Do not apply Input Voltage exceeding V<sub>DD</sub> or 7 V.

## Electrical Characteristics

(V<sub>DD</sub> = 3.0 V, Ta = 25°C)

Items	Symbol	Min	Typ	Max	Unit	Test Condition
Input offset voltage	V <sub>IO</sub>	—	—	4.0	mV	V <sub>in</sub> = 1.5 V
Input offset current	I <sub>IO</sub>	—	(1.0)	—	pA	V <sub>in</sub> = 1.5 V
Input bias current	I <sub>IB</sub>	—	(1.0)	—	pA	V <sub>in</sub> = 1.5 V
Output high voltage	V <sub>OH</sub>	2.9	—	—	V	R <sub>L</sub> = 1 MΩ
Output source current	I <sub>O SOURCE</sub>	6	12	—	μA	V <sub>OH</sub> = 2.5 V (HA1630Q01)
		25	50	—		V <sub>OH</sub> = 2.5 V (HA1630Q02)
		50	100	—		V <sub>OH</sub> = 2.5 V (HA1630Q03)
Output low voltage	V <sub>OL</sub>	—	—	0.1	V	R <sub>L</sub> = 1 MΩ
Output sink current	I <sub>O SINK</sub>	—	(0.8)	—	mA	V <sub>OL</sub> = 0.5 V (HA1630Q01)
		—	(1.0)	—		V <sub>OL</sub> = 0.5 V (HA1630Q02)
		—	(1.2)	—		V <sub>OL</sub> = 0.5 V (HA1630Q03)
Common mode input voltage range	V <sub>CM</sub>	-0.1 to 2.1	—	—	V	
Slew rate	SR	—	(0.125)	—	V/μs	C <sub>L</sub> = 20 pF (HA1630Q01)
		—	(0.50)	—		C <sub>L</sub> = 20 pF (HA1630Q02)
		—	(1.00)	—		C <sub>L</sub> = 20 pF (HA1630Q03)
Voltage gain	A <sub>V</sub>	60	80	—	dB	
Gain bandwidth product	BW	—	(200)	—	kHz	C <sub>L</sub> = 20 pF (HA1630Q01)
		—	(680)	—		C <sub>L</sub> = 20 pF (HA1630Q02)
		—	(1200)	—		C <sub>L</sub> = 20 pF (HA1630Q03)
Power supply rejection ratio	PSRR	60	80	—	dB	
Common mode rejection ratio	CMRR	60	80	—	dB	
Supply current	I <sub>DD</sub>	—	60	120	μA	R <sub>L</sub> = ∞ (HA1630Q01)
		—	200	400		R <sub>L</sub> = ∞ (HA1630Q02)
		—	400	800		R <sub>L</sub> = ∞ (HA1630Q03)

Note: 1. ( ) : Design specification

## Table of Graphs

Electrical Characteristics			HA1630Q01 Figure	HA1630Q02 Figure	HA1630Q03 Figure	Test Circuit
Supply current	$I_{DD}$	vs Supply voltage	1-1	2-1	3-1	2
		vs Ambient temperature	1-2	2-2	3-2	
Output high voltage	$V_{OH}$	vs Output source current	1-3	2-3	3-3	4
		vs Supply voltage	1-4	2-4	3-4	
Output source current	$I_{O\ SOURCE}$	vs Ambient temperature	1-5	2-5	3-5	6
Output low voltage	$V_{OL}$	vs Output sink current	1-6	2-6	3-6	5
Output sink current	$I_{O\ SINK}$	vs Ambient temperature	1-7	2-7	3-7	6
Input offset voltage	$V_{IO}$	Distribution	1-8	2-8	3-8	1
		vs Supply voltage	1-9	2-9	3-9	
		vs Ambient temperature	1-10	2-10	3-10	
Common mode input voltage range	$V_{CM}$	vs Ambient temperature	1-11	2-11	3-11	7
Power supply rejection ratio	PSRR	vs Frequency	1-12	2-12	3-12	1
Common mode rejection ratio	CMRR	vs Frequency	1-13	2-13	3-13	7
Voltage gain & phase angle	$A_V$	vs Frequency	1-14	2-14	3-14	10
Input bias current	$I_{IB}$	vs Ambient temperature	1-15	2-15	3-15	3
		vs Input voltage	1-16	2-16	3-16	
Slew Rate (rising)	SRr	vs Ambient temperature	1-17	2-17	3-17	9
Slew Rate (falling)	SRf	vs Ambient temperature	1-18	2-18	3-18	
Slew rate		Large signal transient response	1-19	2-19	3-19	
		Small signal transient response	1-20	2-20	3-20	
Total harmonic distortion + noise	(0 dB)	vs. Output voltage p-p	—	2-21	3-21	8
	(40 dB)	vs. Output voltage p-p	—	2-22	3-22	
Maximum p-p output voltage		vs Frequency	1-21	2-23	3-23	
Voltage noise density		vs Frequency	1-22	2-24	3-24	

Main Characteristics (HA1630Q01)

Figure 1-1. HA1630Q01  
Supply Current vs. Supply Voltage

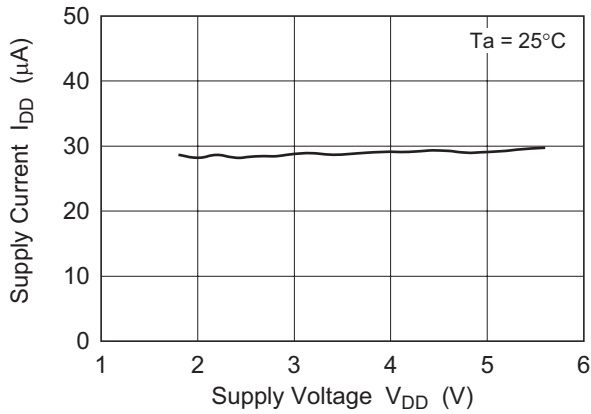

Figure 1-2. HA1630Q01  
Supply Current vs. Ambient Temperature

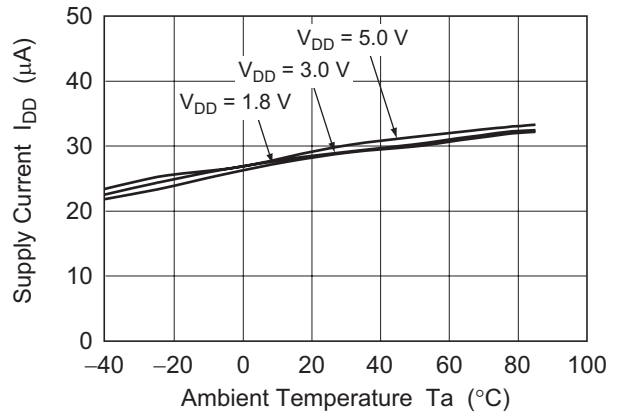

Figure 1-3. HA1630Q01  
Output High Voltage vs. Output Source Current

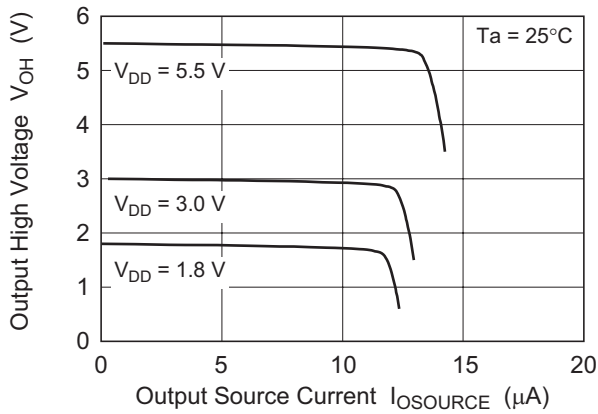

Figure 1-4. HA1630Q01  
Output High Voltage vs. Supply Voltage

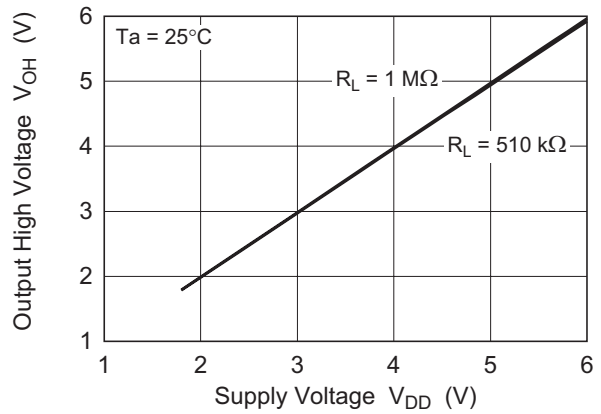
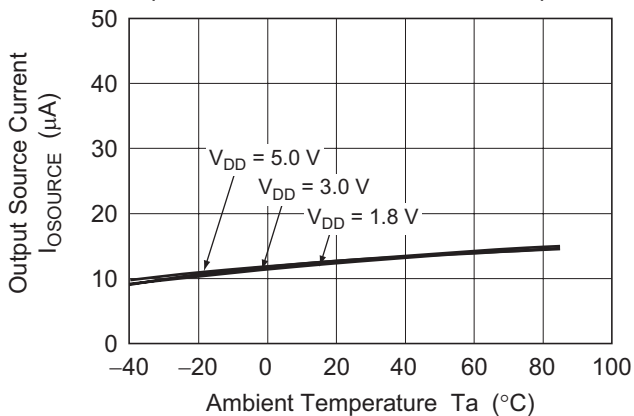

Figure 1-5. HA1630Q01  
Output Source Current vs. Ambient Temperature



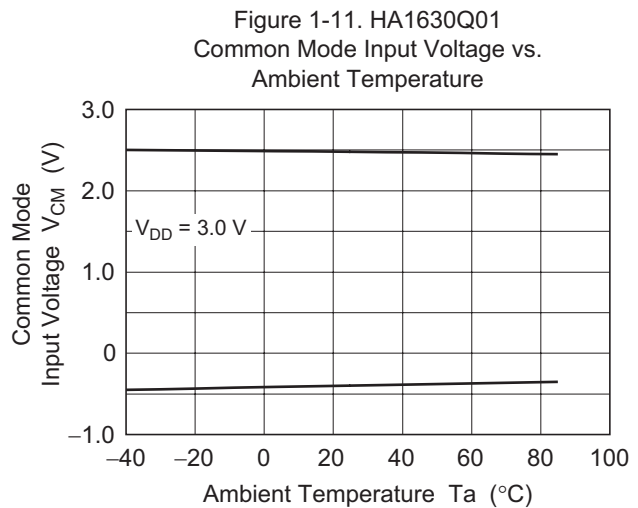
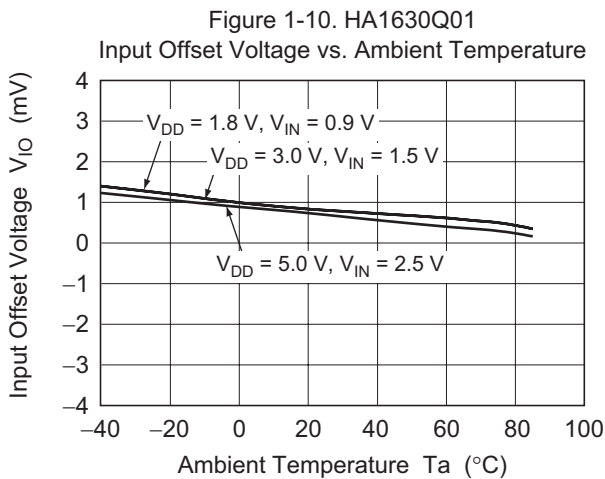
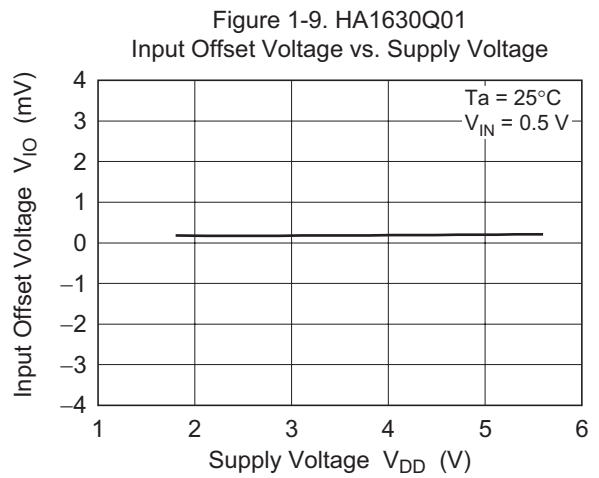
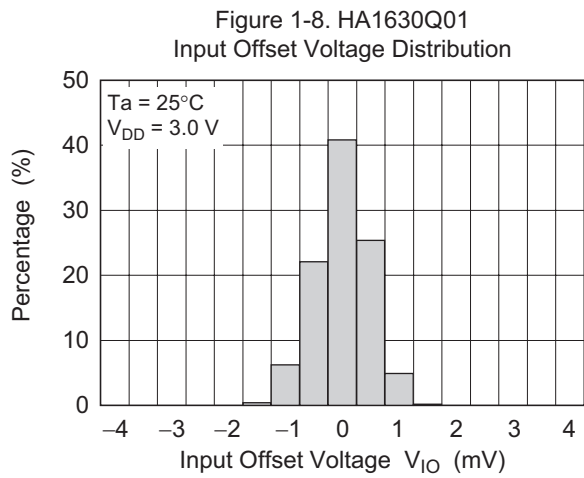
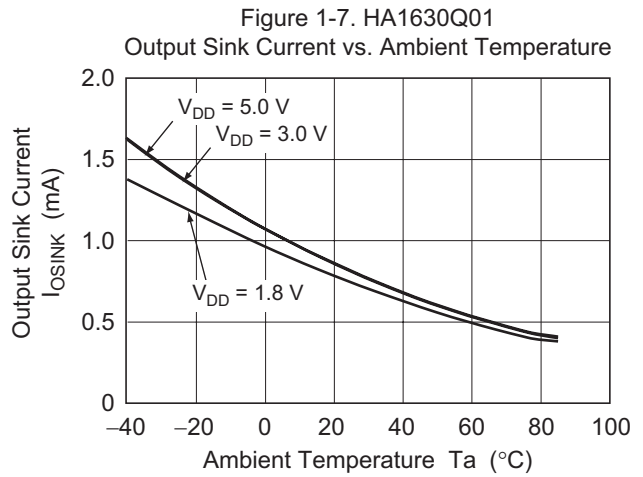
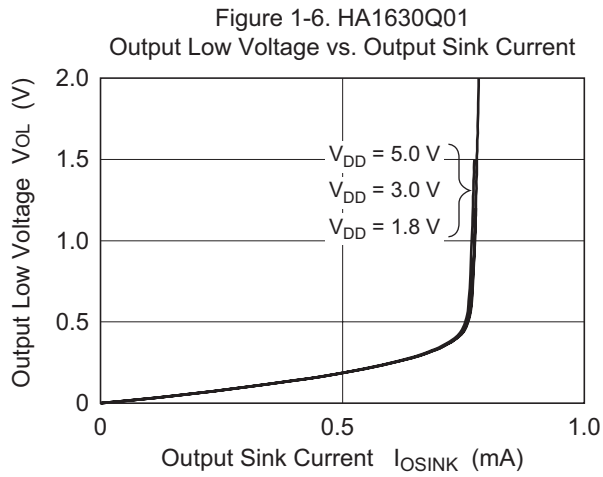

Figure 1-12. HA1630Q01  
Power Supply Rejection Ratio vs. Frequency

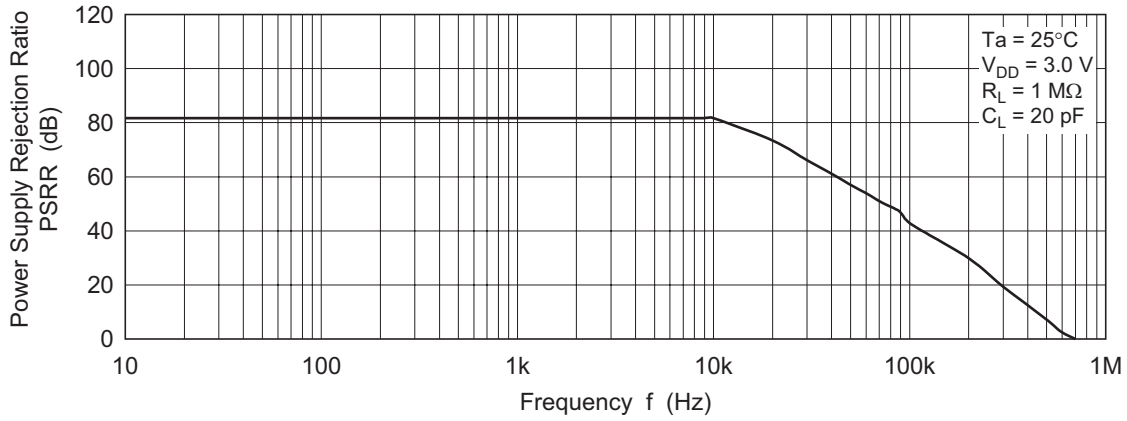

Figure 1-13. HA1630Q01  
Common Mode Rejection Ratio vs. Frequency

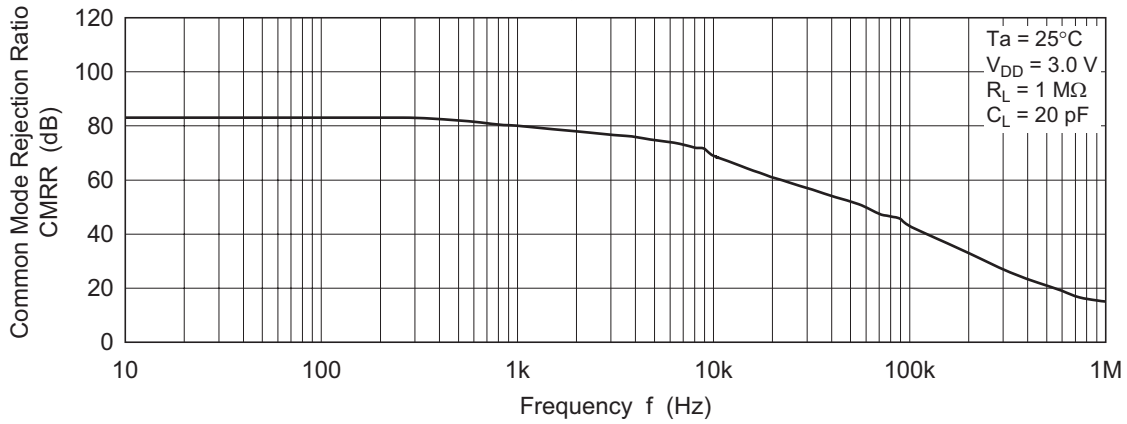
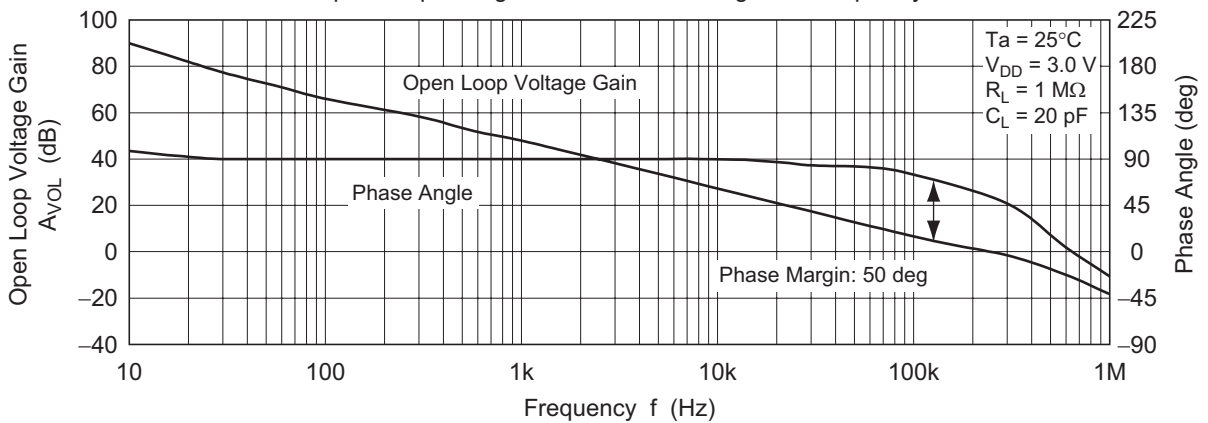

Figure 1-14. HA1630Q01  
Open Loop Voltage Gain and Phase Angle vs. Frequency



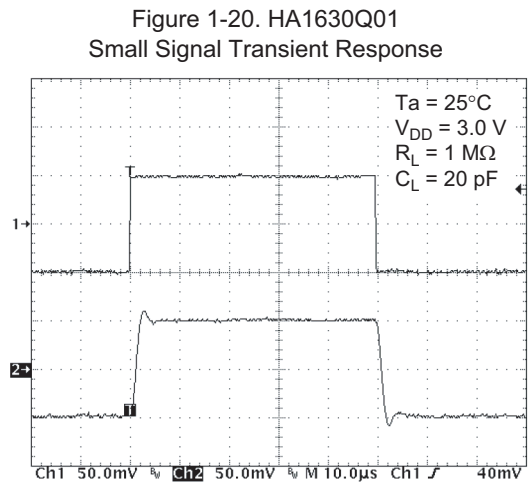
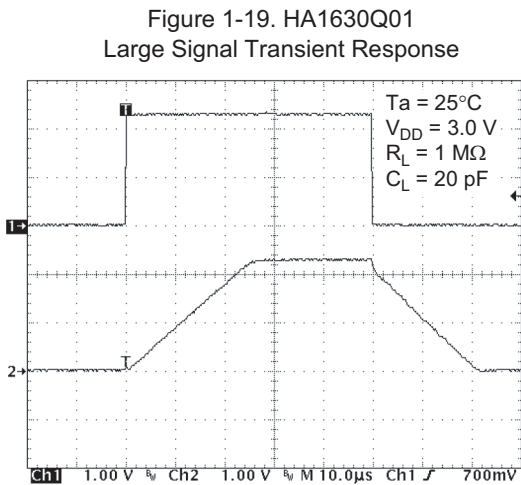
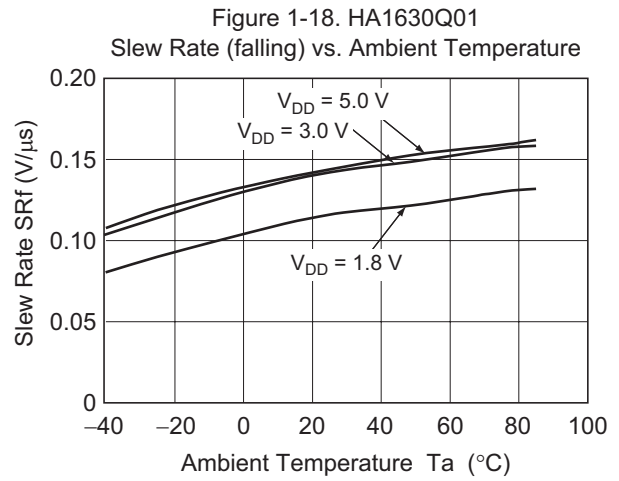
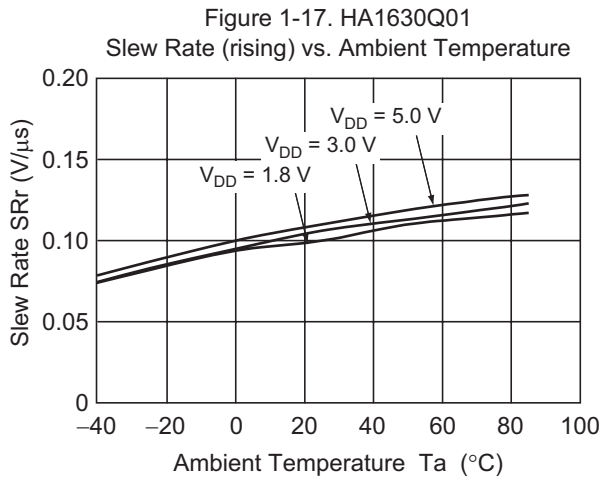
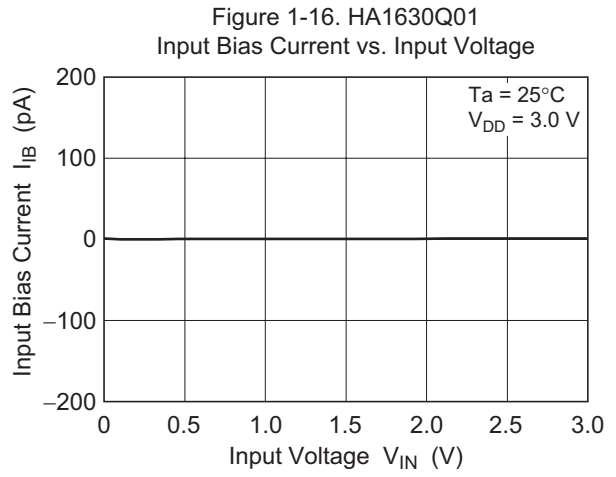
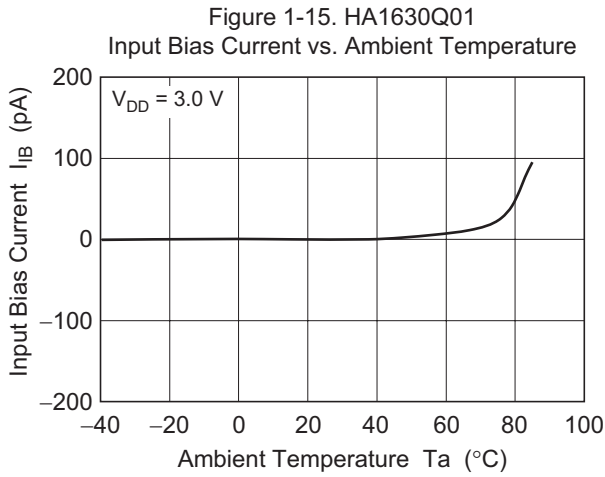



Figure 1-21. HA1630Q01  
Voltage Output p-p vs. Frequency

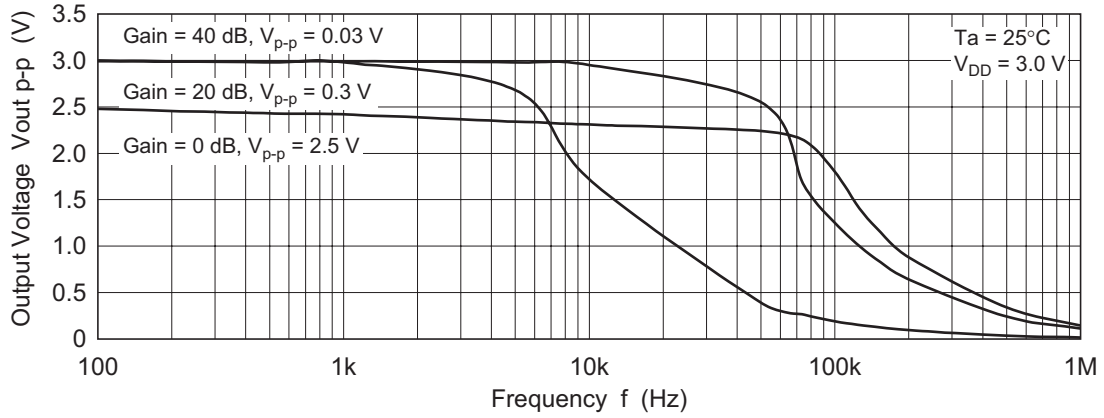
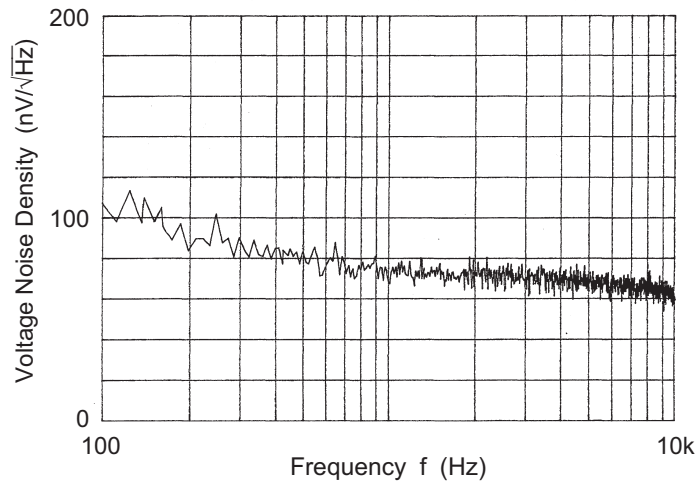

Figure 1-22. HA1630Q01  
Voltage Noise Density vs. Frequency



Main Characteristics (HA1630Q02)

Figure 2-1. HA1630Q02  
Supply Current vs. Supply Voltage

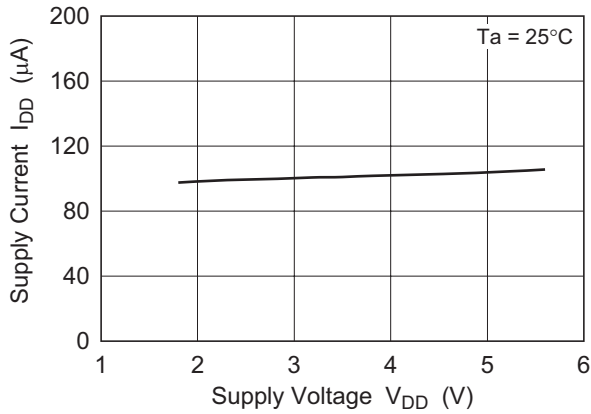

Figure 2-2. HA1630Q02  
Supply Current vs. Ambient Temperature

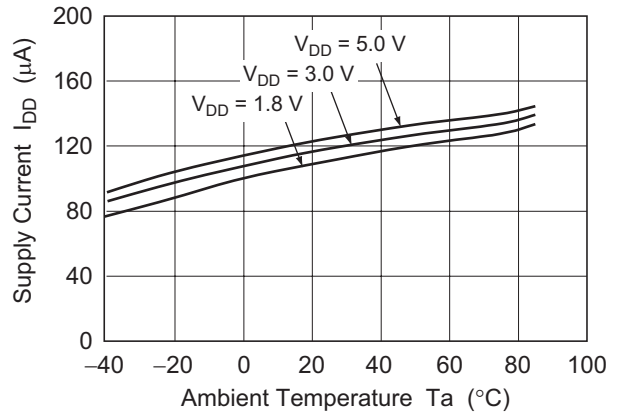

Figure 2-3. HA1630Q02  
Output High Voltage vs. Output Source Current

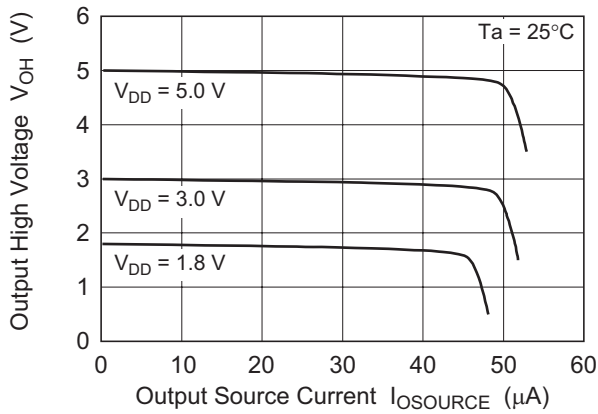

Figure 2-4. HA1630Q02  
Output High Voltage vs. Supply Voltage

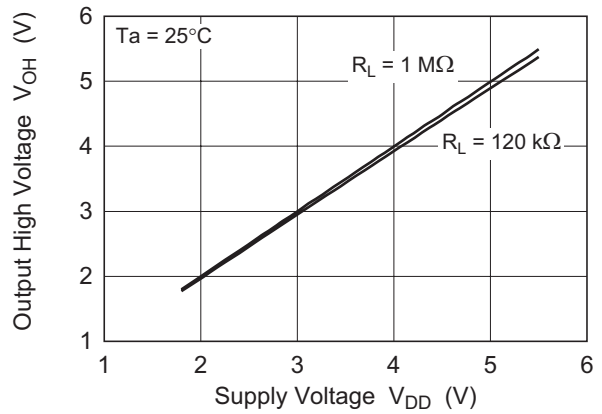
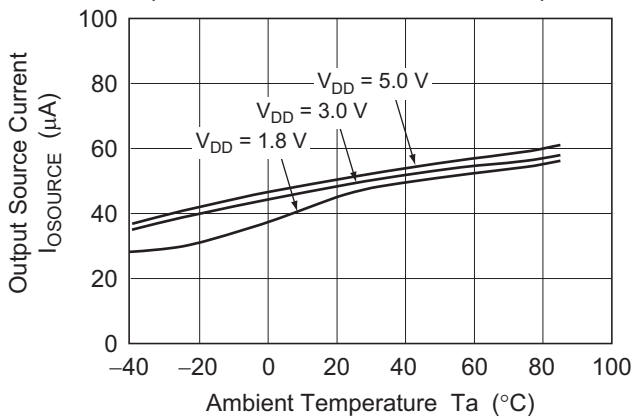

Figure 2-5. HA1630Q02  
Output Source Current vs. Ambient Temperature



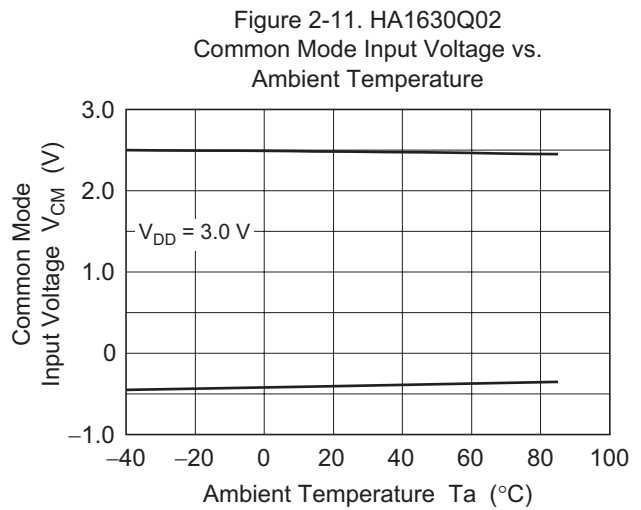
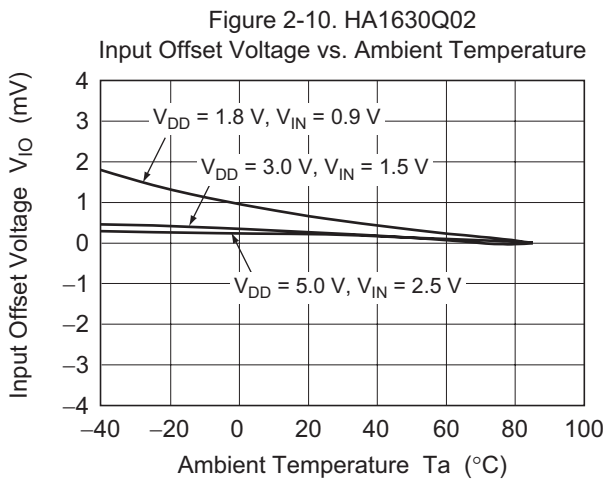
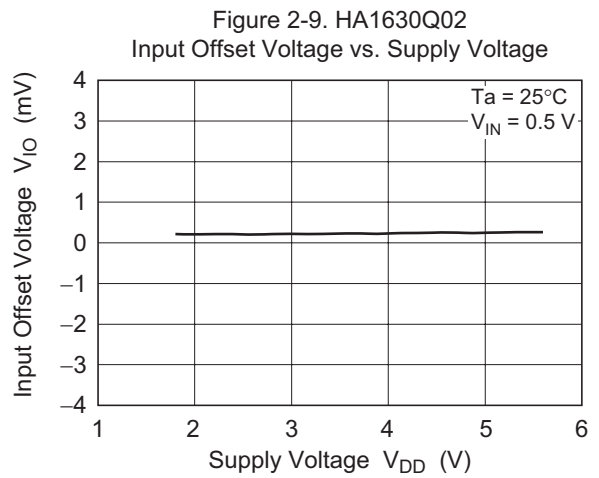
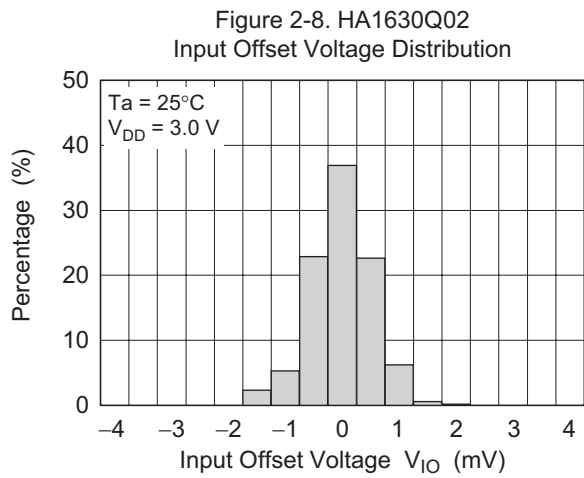
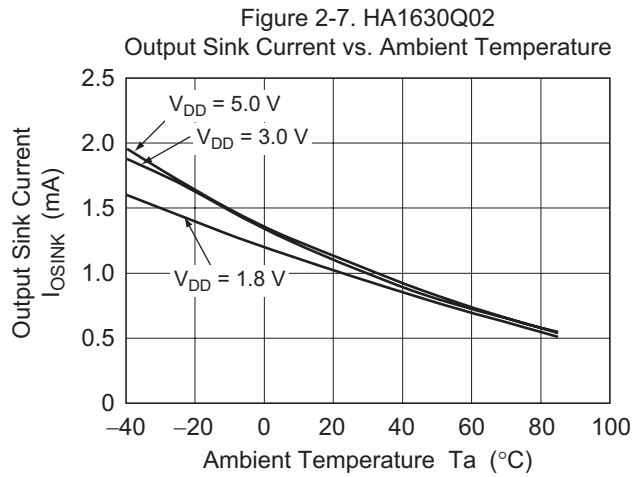
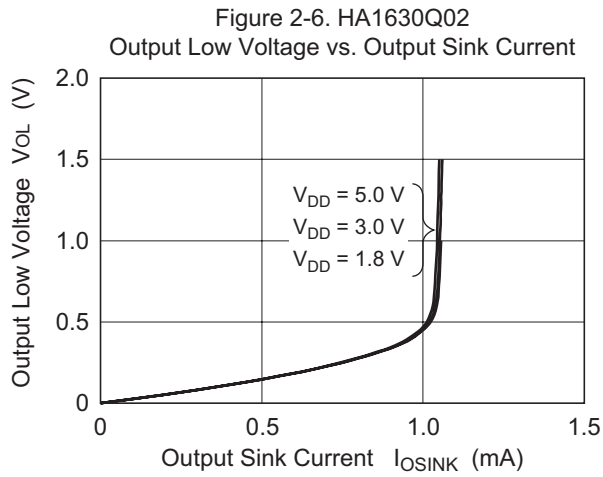

Figure 2-12. HA1630Q02  
Power Supply Rejection Ratio vs. Frequency

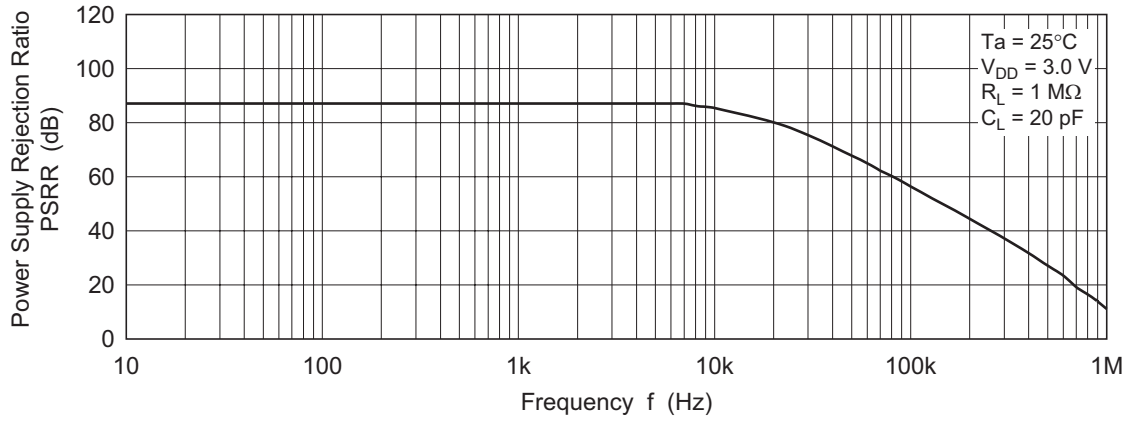

Figure 2-13. HA1630Q02  
Common Mode Rejection Ratio vs. Frequency

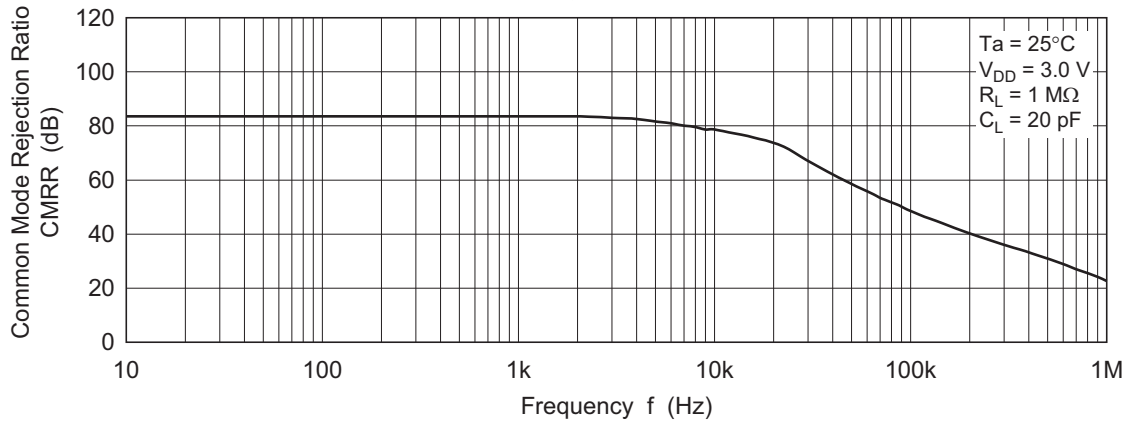
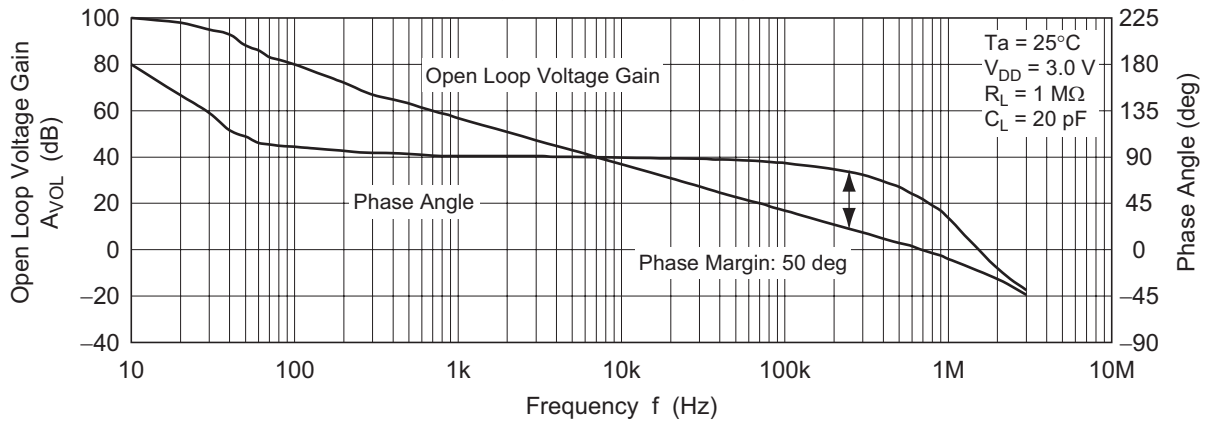

Figure 2-14. HA1630Q02  
Open Loop Voltage Gain and Phase Angle vs. Frequency



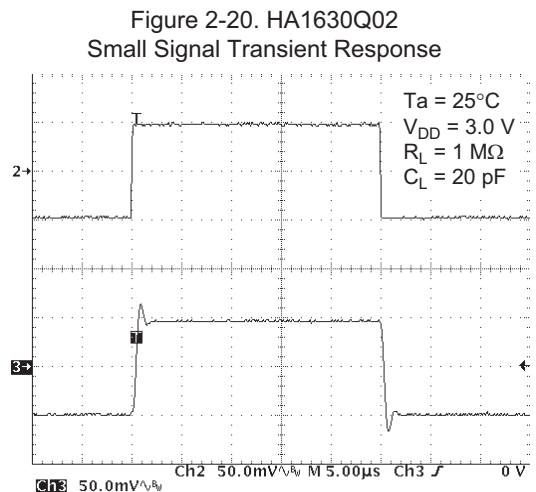
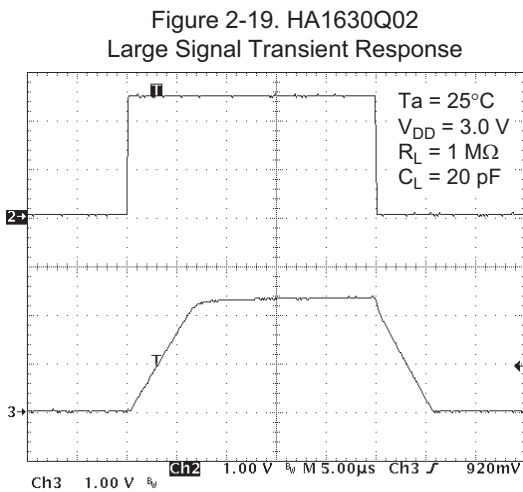
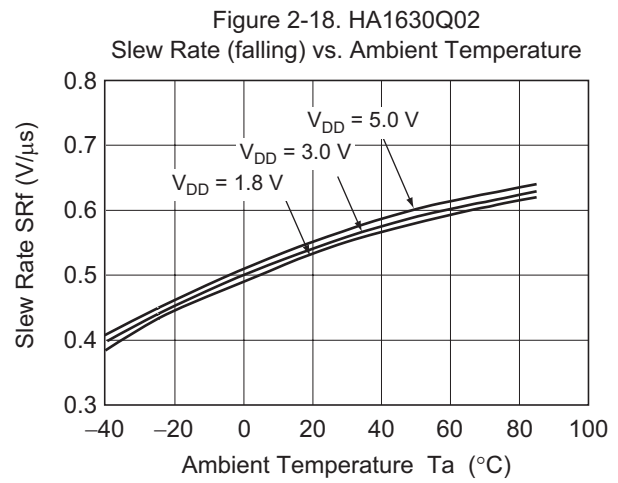
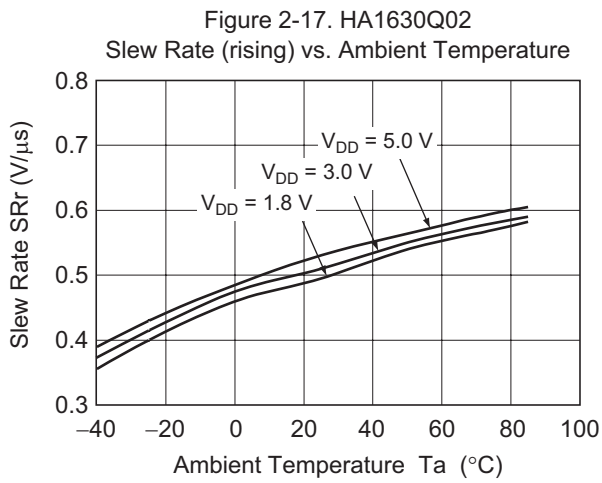
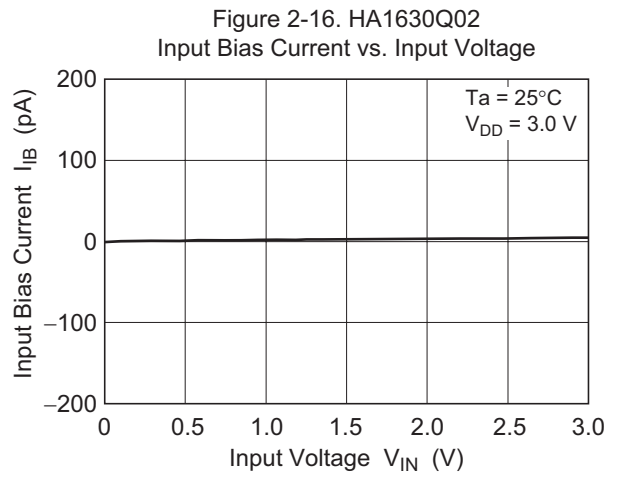
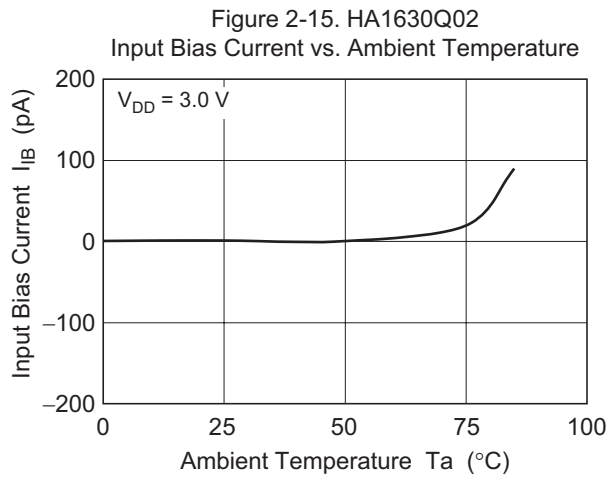

Figure 2-21. HA1630Q02  
Total Harmonic Distortion + Noise vs.  
Output Voltage p-p

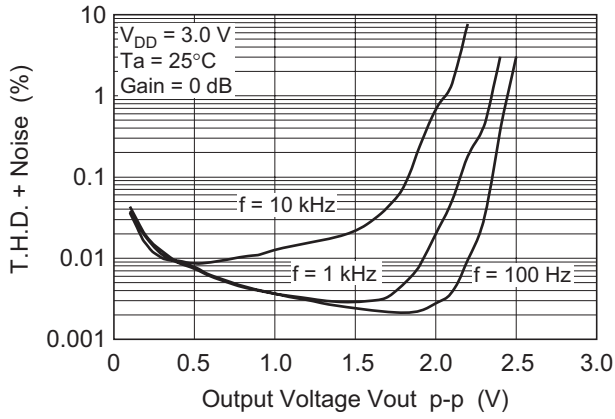

Figure 2-22. HA1630Q02  
Total Harmonic Distortion + Noise vs.  
Output Voltage p-p

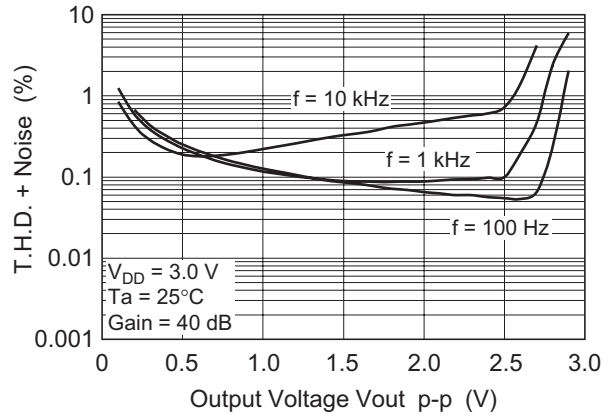

Figure 2-23. HA1630Q02  
Voltage Output p-p vs. Frequency

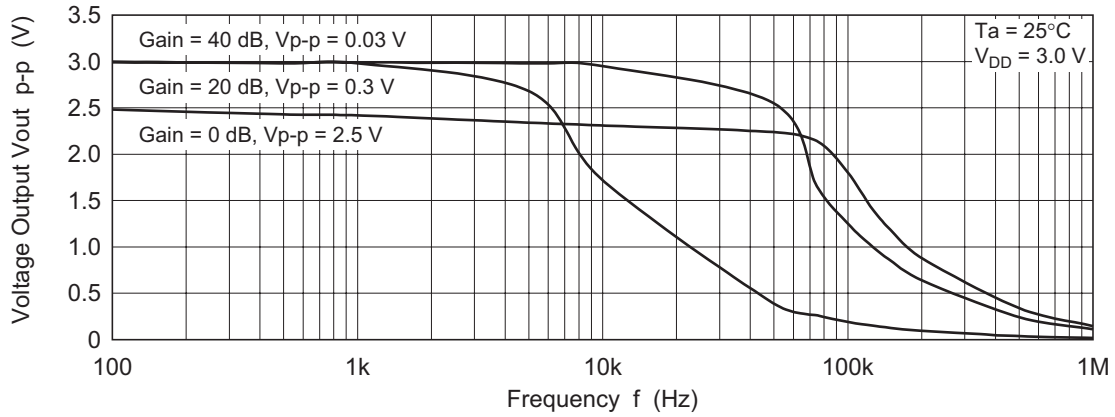
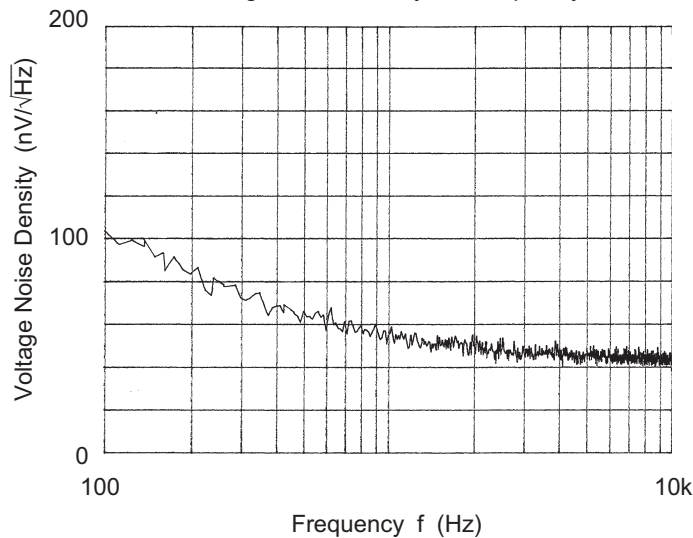
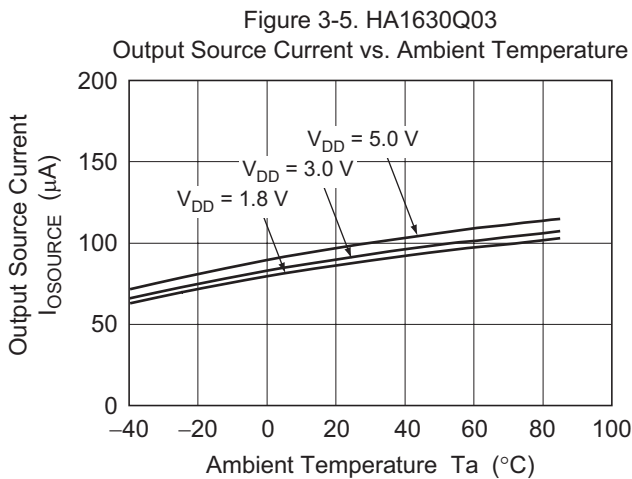
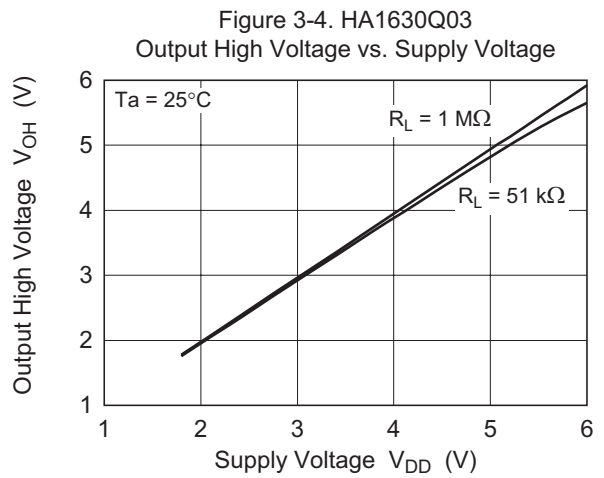
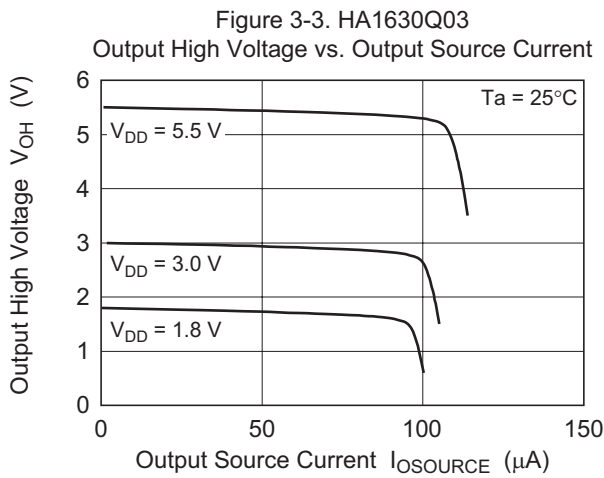
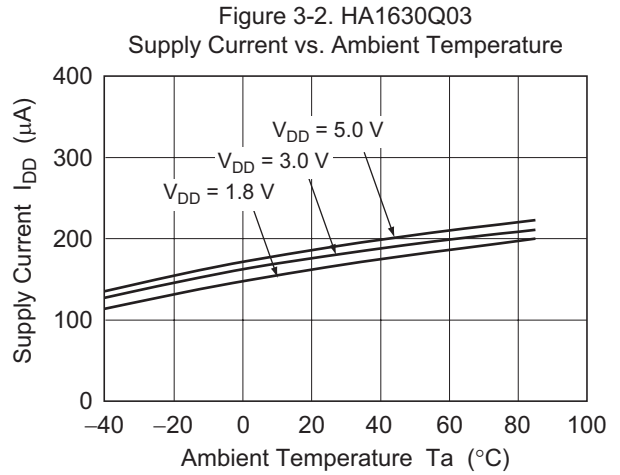
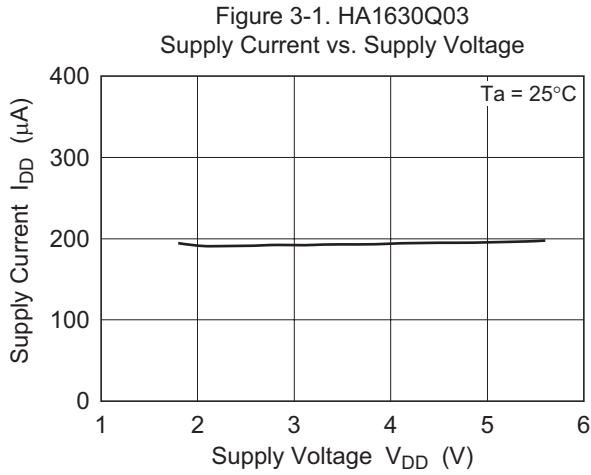

Figure 2-24. HA1630Q02  
Voltage Noise Density vs. Frequency



Main Characteristics (HA1630Q03)



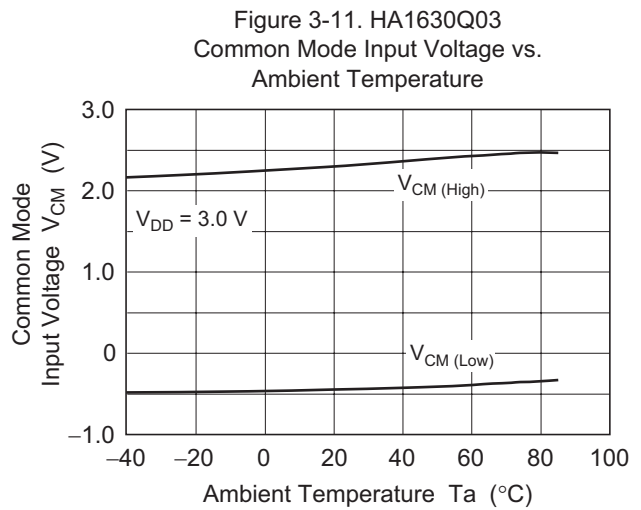
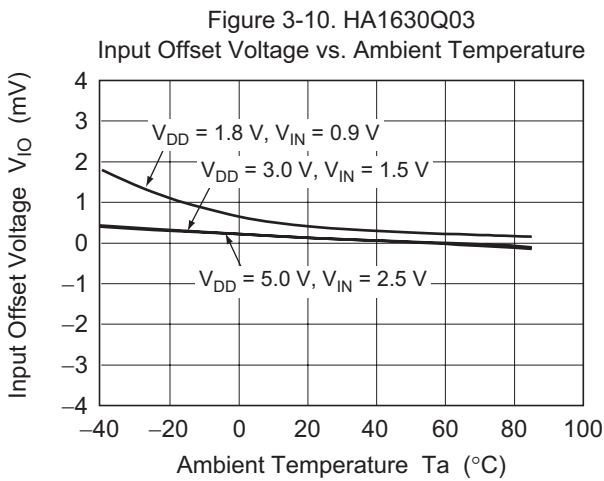
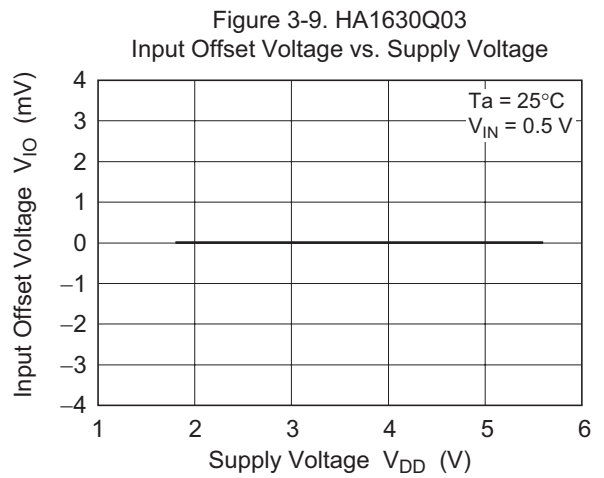
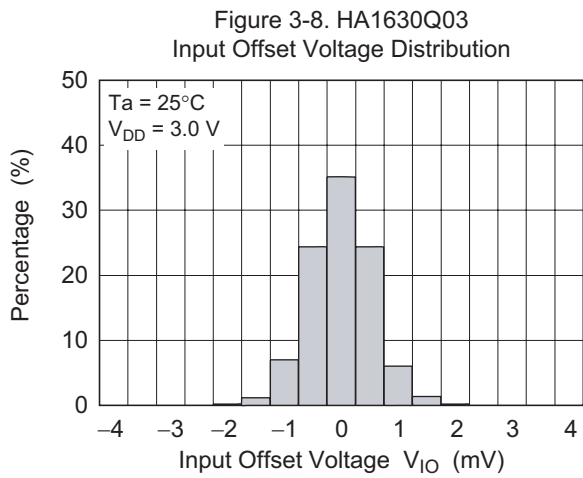
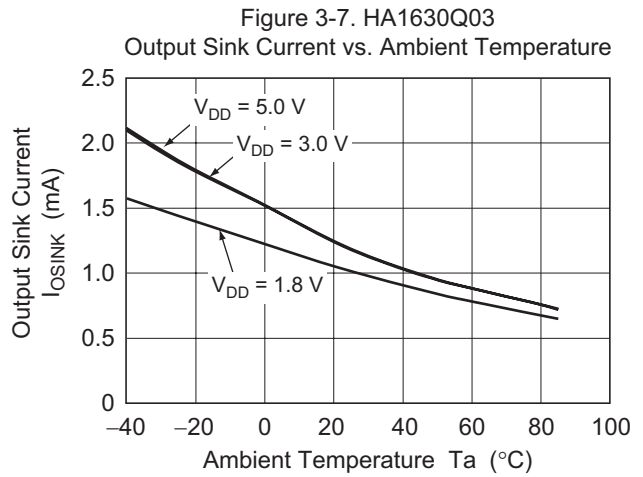
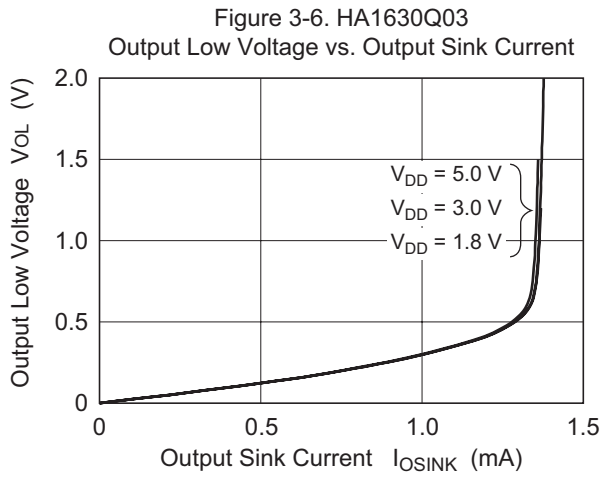



Figure 3-12. HA1630Q03  
Power Supply Rejection Ratio vs. Frequency

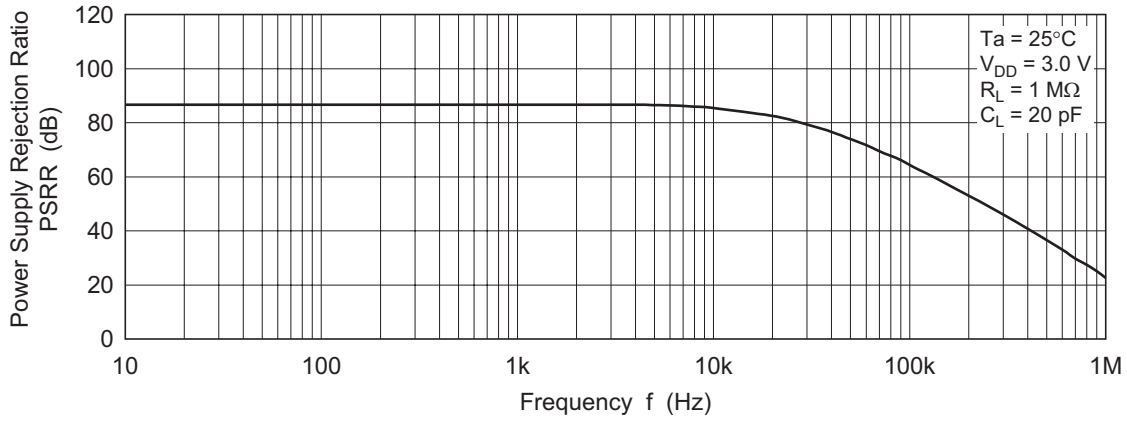

Figure 3-13. HA1630Q03  
Common Mode Rejection Ratio vs. Frequency

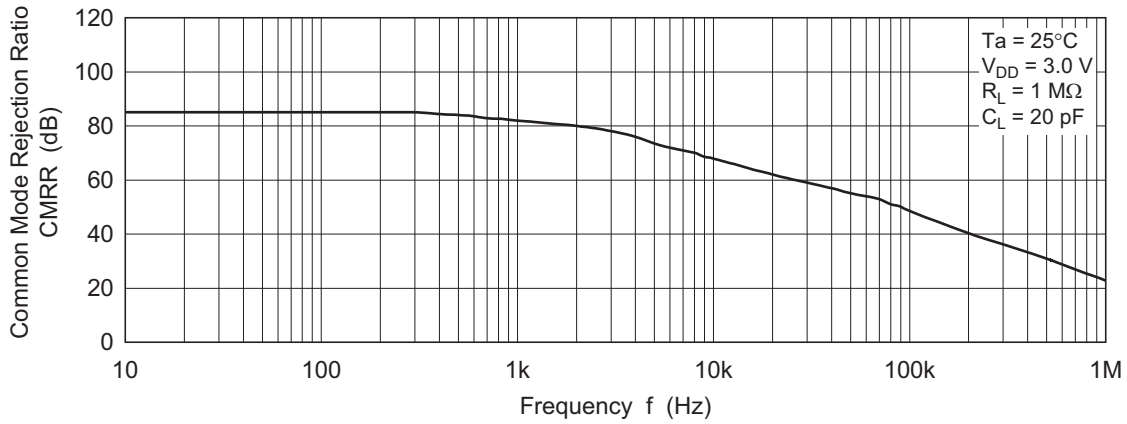
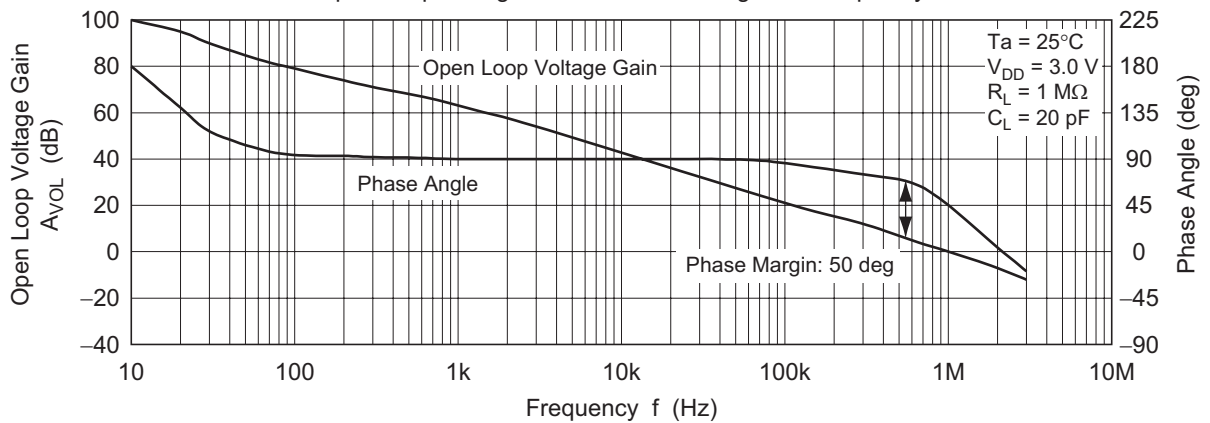

Figure 3-14. HA1630Q03  
Open Loop Voltage Gain and Phase Angle vs. Frequency



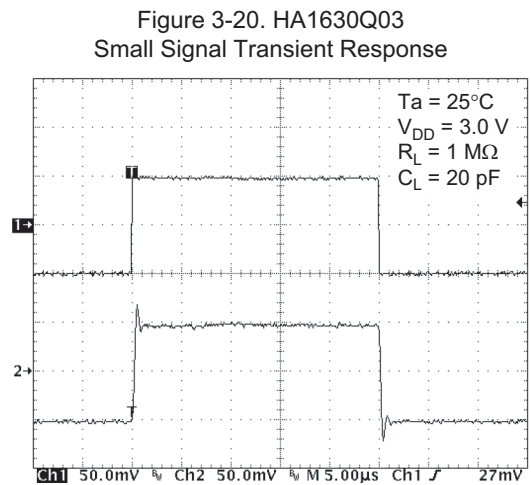
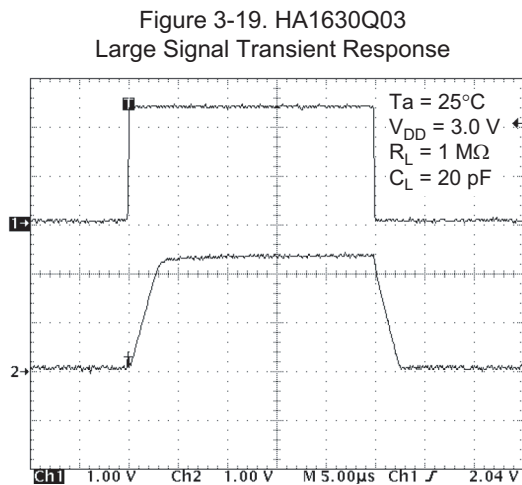
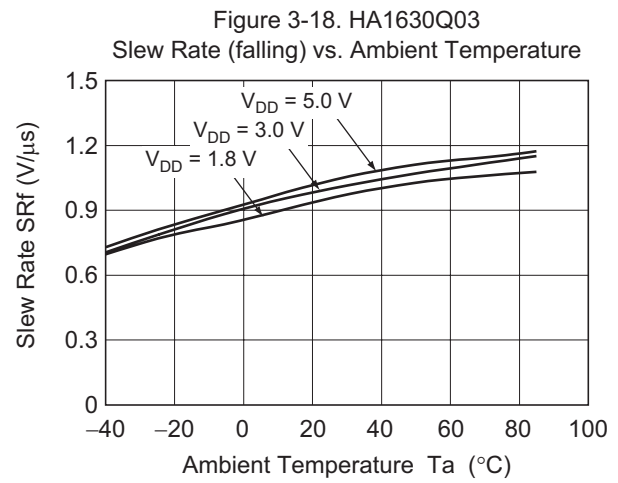
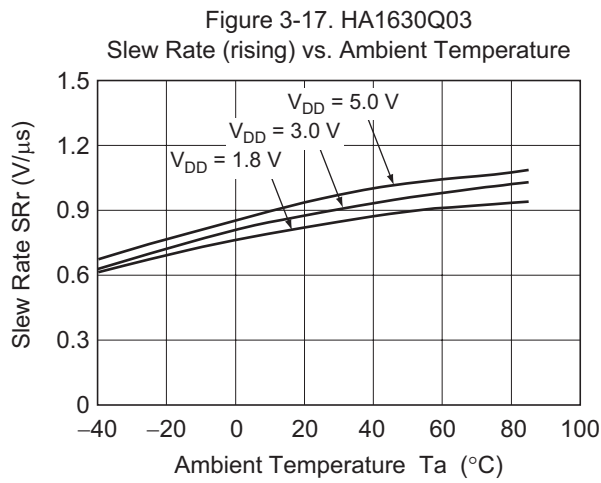
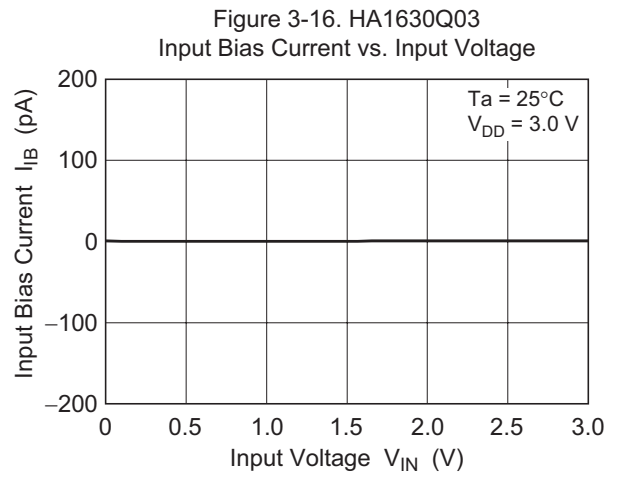
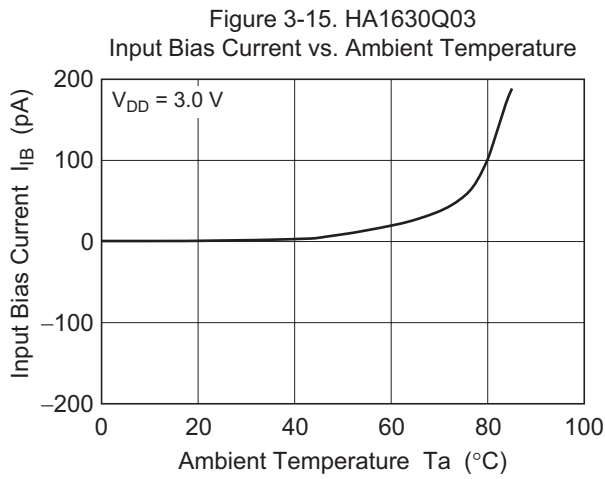

Figure 3-21. HA1630Q03  
Total Harmonic Distortion + Noise vs.  
Output Voltage p-p

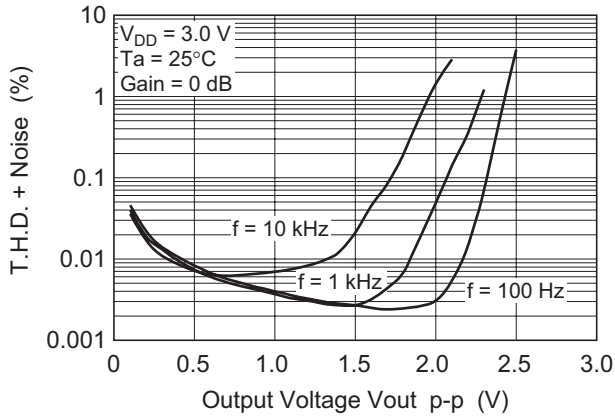

Figure 3-22. HA1630Q03  
Total Harmonic Distortion + Noise vs.  
Output Voltage p-p

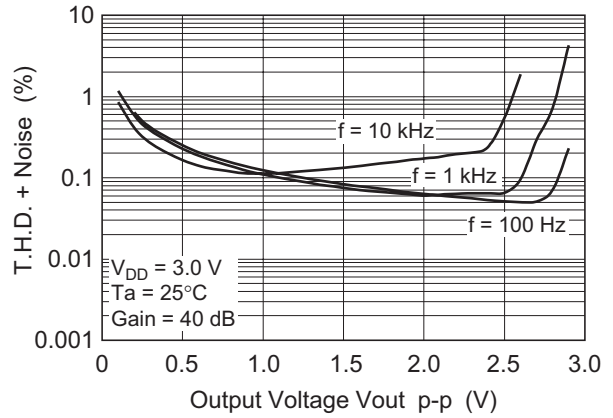

Figure 3-23. HA1630Q03  
Voltage Output p-p vs. Frequency

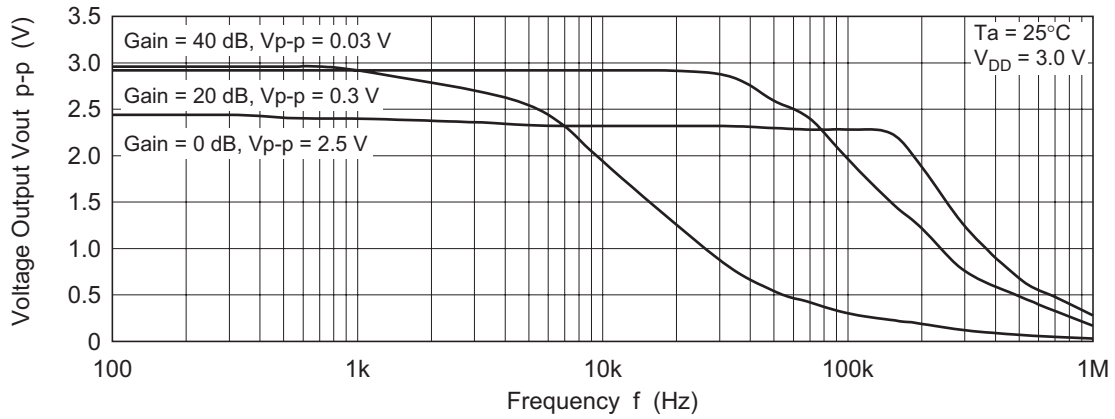
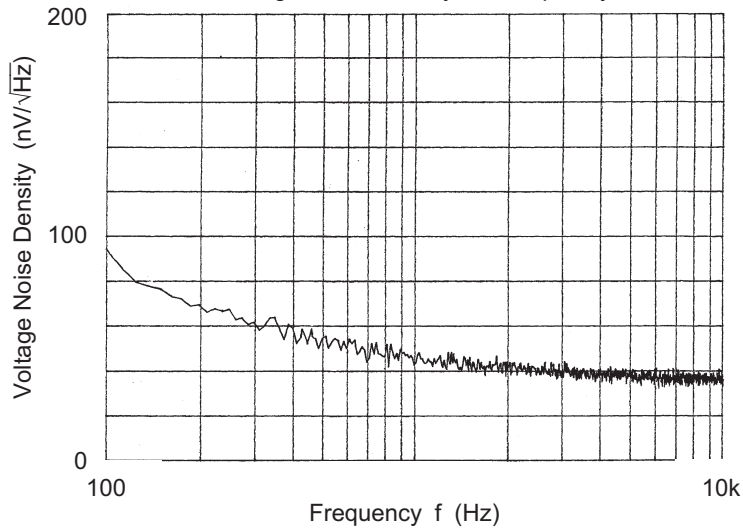
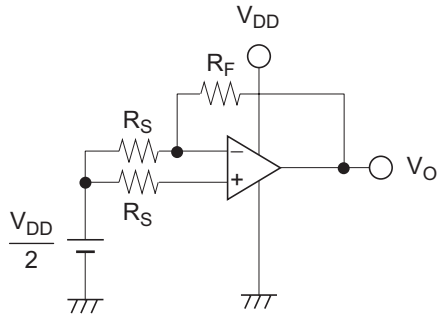

Figure 3-24. HA1630Q03  
Voltage Noise Density vs. Frequency



Test Circuits

1. Power Supply Rejection Ratio, PSRR & Voltage Offset,  $V_{IO}$



$$\frac{V_{IO}}$$

$$V_{IO} = \left( V_O - \frac{V_{DD}}{2} \right) \times \frac{R_S}{R_S + R_F}$$

$$\text{PSRR}$$

$$\text{PSRR} = -20 \log \left( \left| \frac{V_{O1} - V_{O2}}{V_{DD1} - V_{DD2}} \right| \times \frac{R_S}{R_S + R_F} \right)$$

Measure  $V_O$  corresponding to  $V_{DD1} = 1.8 \text{ V}$  and  $V_{DD2} = 5.5 \text{ V}$

2. Supply Current,  $I_{DD}$

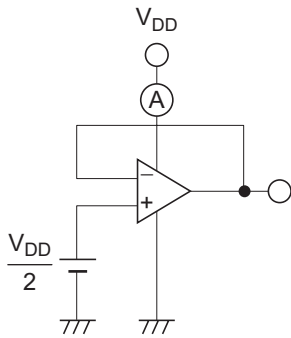

3. Input Bias Current,  $I_B$

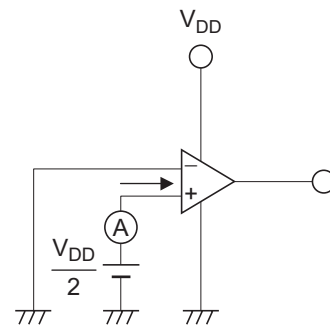

4. Output High Voltage,  $V_{OH}$

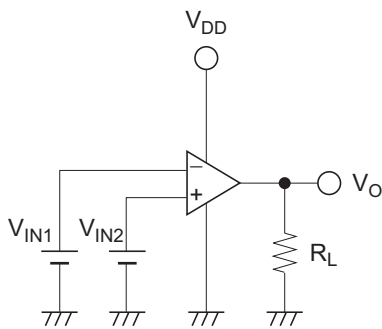

$$\frac{V_{OH}}$$

$$R_L = 1 \text{ M}\Omega$$

$$V_{IN1} = V_{DD} / 2 - 0.05 \text{ V}$$

$$V_{IN2} = V_{DD} / 2 + 0.05 \text{ V}$$

5. Output Low Voltage,  $V_{OL}$

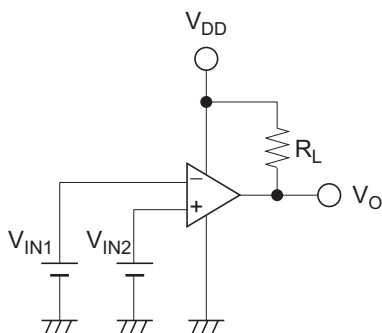

$$\frac{V_{OL}}$$

$$R_L = 1 \text{ M}\Omega$$

$$V_{IN1} = V_{DD} / 2 + 0.05 \text{ V}$$

$$V_{IN2} = V_{DD} / 2 - 0.05 \text{ V}$$

6. Output Source Current,  $I_{OSOURCE}$  & Output Sink Current,  $I_{OSINK}$

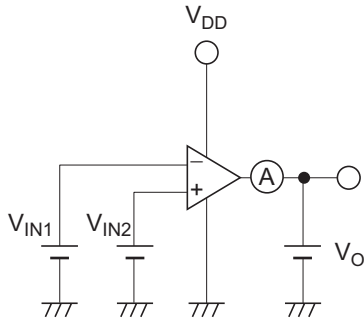

$I_{OSOURCE}$

$$\begin{aligned} V_O &= V_{DD} - 0.5 \text{ V} \\ V_{IN1} &= V_{DD} / 2 - 0.05 \text{ V} \\ V_{IN2} &= V_{DD} / 2 + 0.05 \text{ V} \end{aligned}$$

$I_{OSINK}$

$$\begin{aligned} V_O &= +0.5 \text{ V} \\ V_{IN1} &= V_{DD} / 2 + 0.05 \text{ V} \\ V_{IN2} &= V_{DD} / 2 - 0.05 \text{ V} \end{aligned}$$

7. Common Mode Input Voltage,  $V_{CM}$  & Common Mode Rejection Ratio, CMRR

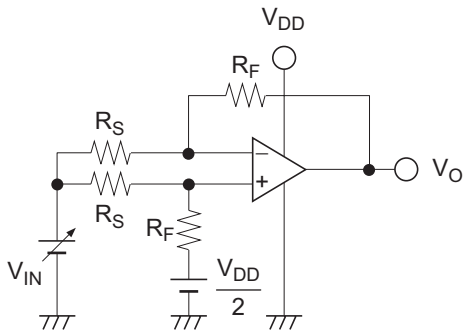

CMRR

$$CMRR = -20 \log \left( \left| \frac{V_{O1} - V_{O2}}{V_{IN1} - V_{IN2}} \right| \times \frac{R_S}{R_S + R_F} \right)$$

Measure  $V_O$  corresponding to  $V_{IN1} = 0 \text{ V}$  and  $V_{IN2} = 2.1 \text{ V}$

8. Total Harmonic Distortion, THD

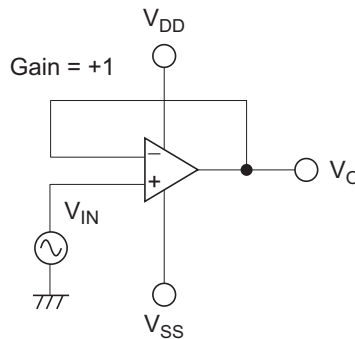
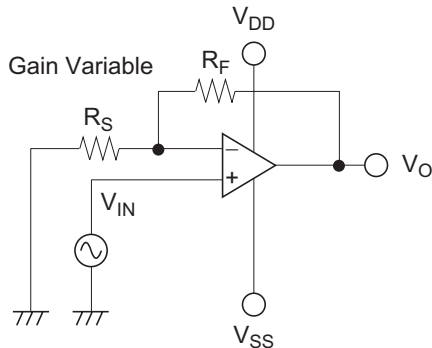

THD

Gain Variable  
 $1 + R_F / R_S = 100$   
 freq = 100 Hz, 1 kHz, 10 kHz

9. Slew Rate, SR

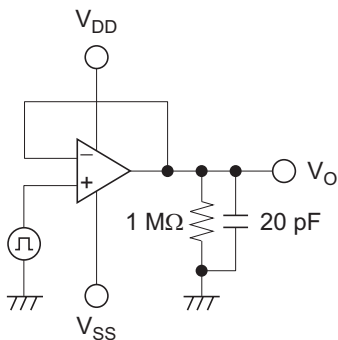

10. Gain,  $A_V$  & Phase, GBW

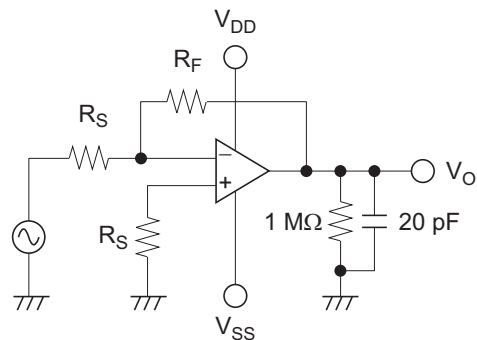

### Package Dimensions

JEITA Package Code	RENESAS Code	Previous Code	MASS[Typ.]
P-TSSOP14-4.4x5-0.65	PTSP0014JA-B	TTP-14DV	0.05g

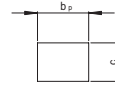
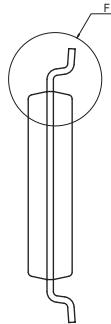
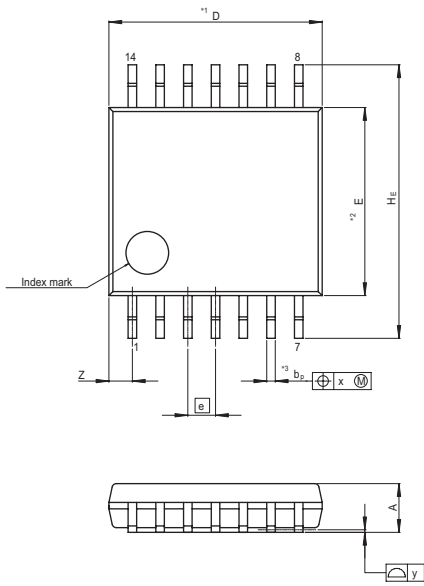

Terminal cross section  
( Ni/Pd/Au plating )

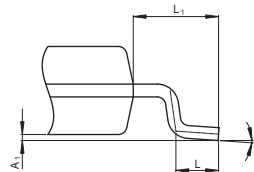

Detail F

NOTE)  
1. DIMENSIONS\*\*1 (Nom)\*\*AND\*\*2"  
DO NOT INCLUDE MOLD FLASH.  
2. DIMENSION\*\*3"DOES NOT  
INCLUDE TRIM OFFSET.

Reference Symbol	Dimension in Millimeters		
	Min	Nom	Max
D	—	5.00	5.30
E	—	4.40	—
A <sub>2</sub>	—	—	—
A <sub>1</sub>	0.03	0.07	0.10
A	—	—	1.10
b <sub>p</sub>	0.15	0.20	0.25
b <sub>1</sub>	—	—	—
c	0.10	0.15	0.20
c <sub>1</sub>	—	—	—
θ	0°	—	8°
H <sub>E</sub>	6.20	6.40	6.60
e	—	0.65	—
x	—	—	0.13
y	—	—	0.10
Z	—	—	0.83
L	0.4	0.5	0.6
L <sub>1</sub>	—	1.0	—

### Taping & Reel Specification

[Taping]

Package Code	W	P	Ao	Bo	Ko	E	F	D1	Maximum Storage No.
TSSOP-14	12	8	6.5	5.1	1.5	—	5.5	1.6	2,000 pcs/reel

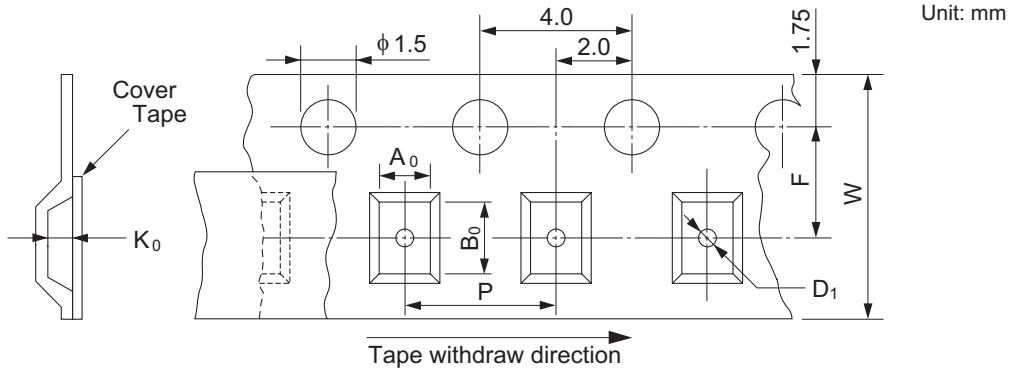

Unit: mm

[Reel]

Package	Tape width	W1	W2
TSSOP-14	12	17.4	13.4

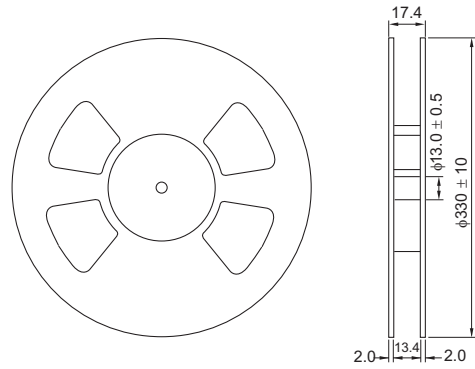

[Ordering Information]

Ordering Unit
2,000 pcs

### Mark Indication

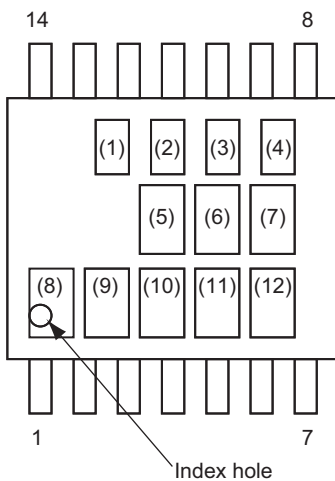

(1) to (4)	Week code		
(5),(8) to (10)	Space		
(6), (7) (11), (12)	Product Name	0Q01	HA1630Q01
		0Q02	HA1630Q02
		0Q03	HA1630Q03

**Keep safety first in your circuit designs!**

1. Renesas Technology Corp. puts the maximum effort into making semiconductor products better and more reliable, but there is always the possibility that trouble may occur with them. Trouble with semiconductors may lead to personal injury, fire or property damage.  
Remember to give due consideration to safety when making your circuit designs, with appropriate measures such as (i) placement of substitutive, auxiliary circuits, (ii) use of nonflammable material or (iii) prevention against any malfunction or mishap.

**Notes regarding these materials**

1. These materials are intended as a reference to assist our customers in the selection of the Renesas Technology Corp. product best suited to the customer's application; they do not convey any license under any intellectual property rights, or any other rights, belonging to Renesas Technology Corp. or a third party.
  2. Renesas Technology Corp. assumes no responsibility for any damage, or infringement of any third-party's rights, originating in the use of any product data, diagrams, charts, programs, algorithms, or circuit application examples contained in these materials.
  3. All information contained in these materials, including product data, diagrams, charts, programs and algorithms represents information on products at the time of publication of these materials, and are subject to change by Renesas Technology Corp. without notice due to product improvements or other reasons. It is therefore recommended that customers contact Renesas Technology Corp. or an authorized Renesas Technology Corp. product distributor for the latest product information before purchasing a product listed herein.  
The information described here may contain technical inaccuracies or typographical errors.  
Renesas Technology Corp. assumes no responsibility for any damage, liability, or other loss rising from these inaccuracies or errors.  
Please also pay attention to information published by Renesas Technology Corp. by various means, including the Renesas Technology Corp. Semiconductor home page (<http://www.renesas.com>).
  4. When using any or all of the information contained in these materials, including product data, diagrams, charts, programs, and algorithms, please be sure to evaluate all information as a total system before making a final decision on the applicability of the information and products. Renesas Technology Corp. assumes no responsibility for any damage, liability or other loss resulting from the information contained herein.
  5. Renesas Technology Corp. semiconductors are not designed or manufactured for use in a device or system that is used under circumstances in which human life is potentially at stake. Please contact Renesas Technology Corp. or an authorized Renesas Technology Corp. product distributor when considering the use of a product contained herein for any specific purposes, such as apparatus or systems for transportation, vehicular, medical, aerospace, nuclear, or undersea repeater use.
  6. The prior written approval of Renesas Technology Corp. is necessary to reprint or reproduce in whole or in part these materials.
  7. If these products or technologies are subject to the Japanese export control restrictions, they must be exported under a license from the Japanese government and cannot be imported into a country other than the approved destination.  
Any diversion or reexport contrary to the export control laws and regulations of Japan and/or the country of destination is prohibited.
  8. Please contact Renesas Technology Corp. for further details on these materials or the products contained therein.
- 



**RENESAS SALES OFFICES**

<http://www.renesas.com>

Refer to "<http://www.renesas.com/en/network>" for the latest and detailed information.

**Renesas Technology America, Inc.**

450 Holger Way, San Jose, CA 95134-1368, U.S.A  
Tel: <1> (408) 382-7500, Fax: <1> (408) 382-7501

**Renesas Technology Europe Limited**

Dukes Meadow, Millboard Road, Bourne End, Buckinghamshire, SL8 5FH, U.K.  
Tel: <44> (1628) 585-100, Fax: <44> (1628) 585-900

**Renesas Technology (Shanghai) Co., Ltd.**

Unit 204, 205, AZIACenter, No.1233 Lujiazui Ring Rd, Pudong District, Shanghai, China 200120  
Tel: <86> (21) 5877-1818, Fax: <86> (21) 6887-7898

**Renesas Technology Hong Kong Ltd.**

7th Floor, North Tower, World Finance Centre, Harbour City, 1 Canton Road, Tsimshatsui, Kowloon, Hong Kong  
Tel: <852> 2265-6688, Fax: <852> 2730-6071

**Renesas Technology Taiwan Co., Ltd.**

10th Floor, No.99, Fushing North Road, Taipei, Taiwan  
Tel: <886> (2) 2715-2888, Fax: <886> (2) 2713-2999

**Renesas Technology Singapore Pte. Ltd.**

1 Harbour Front Avenue, #06-10, Keppel Bay Tower, Singapore 098632  
Tel: <65> 6213-0200, Fax: <65> 6278-8001

**Renesas Technology Korea Co., Ltd.**

Kukje Center Bldg. 18th Fl., 191, 2-ka, Hangang-ro, Yongsan-ku, Seoul 140-702, Korea  
Tel: <82> (2) 796-3115, Fax: <82> (2) 796-2145

**Renesas Technology Malaysia Sdn. Bhd**

Unit 906, Block B, Menara Amcorp, Amcorp Trade Centre, No.18, Jalan Persiaran Barat, 46050 Petaling Jaya, Selangor Darul Ehsan, Malaysia  
Tel: <603> 7955-9390, Fax: <603> 7955-9510