



NPN Silicon Bipolar Common Emitter Transistor

Technical Data

AT-38043

Features

- Operates Over a Wide Range of Voltages and Frequencies
- +25.0 dBm P_{1dB} and 60% Collector Efficiency @ 900 MHz, 4.8 Volts, Typ.
- 15 dB G_{1dB} @ 900 MHz, 4.8 Volts, Typ.
- -35 dBc IMD_3 @ P_{out} of +14 dBm per tone, 900 MHz, 3 Volts, Typ.
- +21.5 dBm P_{1dB} and 50% Collector Efficiency @ 1900 MHz, 3 Volts, Typ.

Applications

- Driver Amplifier for GSM and AMPS/ETACS/NMT Cellular Phones
- 900 and 1800 MHz ISM
- Special Mobile Radio, CATV
- 1900 MHz US PCS

Surface Mount Package SOT-343 (SC-70) Outline 4T

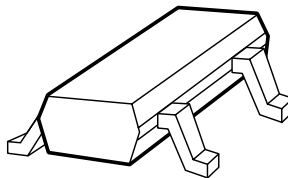

Pin Configuration

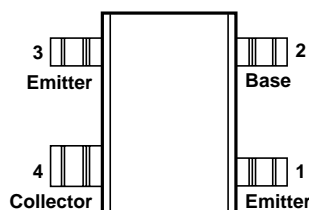

Description

Agilent's AT-38043 is a low cost, NPN silicon bipolar junction transistor housed in a miniature SC-70 surface mount plastic package. This device can be used as a pre-driver, driver, or output device in many applications for cellular and other wireless communications markets. At 4.8 volts, the AT-38043 features +25 dBm output power, while providing 15 dB of gain and 60% collector efficiency. Superior efficiency and gain make the AT-38043 an excellent choice for battery powered systems.

The AT-38043 is fabricated with Agilent's 10 GHz F_t Self-Aligned-Transistor (SAT) process. The die are nitride passivated for surface protection. Excellent device uniformity, performance and reliability are produced by the use of ion-implantation, self-alignment techniques, and gold metalization in the fabrication of these devices.

AT-38043 Absolute Maximum Ratings

Symbol	Parameter	Units	Absolute Maximum ^[1]
V _{EBO}	Emitter-Base Voltage	V	1.4
V _{CBO}	Collector-Base Voltage	V	16.0
V _{CEO}	Collector-Emitter Voltage	V	9.5
I _C	Collector Current	mA	160
P _T	Power Dissipation ^[2]	mW	500
T _J	Junction Temperature	°C	150
T _{STG}	Storage Temperature	°C	-65 to 150

Thermal Resistance^[3]:

$$\theta_{jc} = 130^{\circ}\text{C/W}$$

Notes:

1. Permanent damage may occur if any of these limits are exceeded.
2. Derate at 7.7 mW/°C for T_C > 85°C. T_C is defined to be the temperature of the collector pin 4, where the lead contacts the circuit board.
3. Using the liquid crystal technique, V_{CE} = 4.8 V, I_C = 50 mA, T_J = 150°C, 1–2 μm “hot-spot” resolution.

Electrical Specifications, T_C = 25°C

Freq. = 900 MHz, V_{CE} = 4.8 V, I_{CQ} = 15 mA, CW operation, Test Circuit A, unless otherwise specified

Symbol	Parameters and Test Conditions	Units	Min.	Typ.	Max.
P _{1dB}	Output Power @ 1 dB Gain Compression ^[1]	dBm	+23.5	+25.0	
G _{1dB}	1 dB Compression Gain ^[1]	dB	13.5	15.0	
η _C	Collector Efficiency @ 1 dB Gain Compression ^[1]	%	45	60	
	Mismatch Tolerance, No Damage ^[1]				7:1
IMD ₃	3rd Order Intermodulation Distortion, 2-Tone Test, P _{out} each tone = +14 dBm ^[1]				
BV _{EBO}	Emitter-Base Breakdown Voltage	I _E = 0.2 mA, open collector	V	1.4	
BV _{CBO}	Collector-Base Breakdown Voltage	I _C = 1.0 mA, open emitter	V	16.0	
BV _{CEO}	Collector-Emitter Breakdown Voltage	I _C = 3.0 mA, open base	V	9.5	
h _{FE}	Forward Current Transfer Ratio	V _{CE} = 3 V, I _C = 160 mA	—	50	150 330
I _{CEO}	Collector Leakage Current	V _{CEO} = 5 V	μA		15

Note:

1. With external matching on input and output, tested in a 50 ohm environment. Refer to Test Circuit A.

AT-38043 Typical Performance, $T_C = 25^\circ\text{C}$

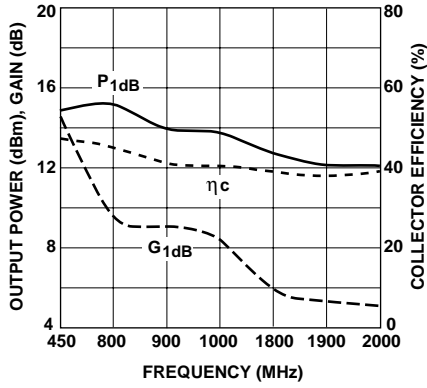

Figure 1. Output Power, Gain, and Collector Efficiency vs. Frequency at $V_{CE} = 1.2\text{ V}$, $I_{CQ} = 15\text{ mA}$.

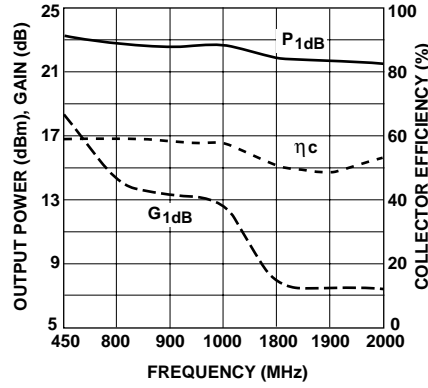

Figure 2. Output Power, Gain, and Collector Efficiency vs. Frequency at $V_{CE} = 3.0\text{ V}$, $I_{CQ} = 15\text{ mA}$.

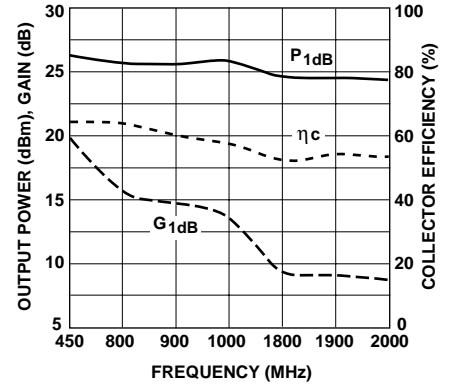

Figure 3. Output Power, Gain, and Collector Efficiency vs. Frequency at $V_{CE} = 4.8\text{ V}$, $I_{CQ} = 15\text{ mA}$.

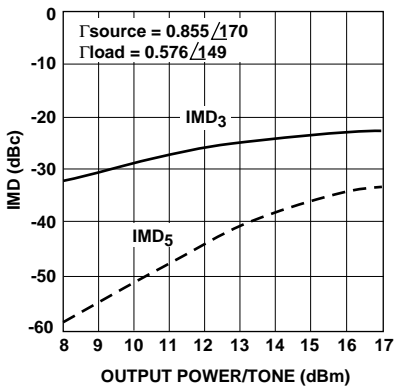

Figure 4. IMD_3 , IMD_5 vs. Output Power (per tone) at $V_{CE} = 3.0\text{ V}$ and $I_{CQ} = 15\text{ mA}$, Frequency = 450 MHz .

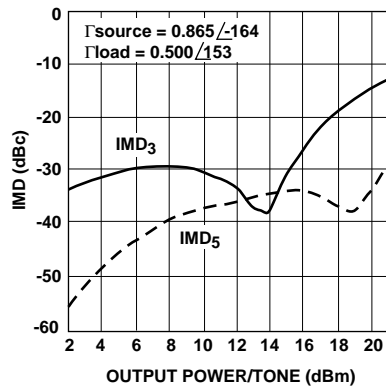

Figure 5. IMD_3 , IMD_5 vs. Output Power (per tone) at $V_{CE} = 3.0\text{ V}$ and $I_{CQ} = 15\text{ mA}$, Frequency = 900 MHz .

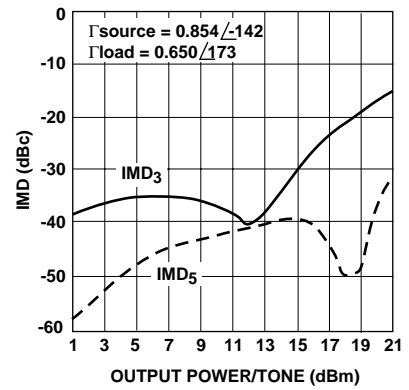

Figure 6. IMD_3 , IMD_5 vs. Output Power (per tone) at $V_{CE} = 3.0\text{ V}$ and $I_{CQ} = 15\text{ mA}$, Frequency = 1900 MHz .

**AT-38043 Typical Performance Under Pulsed Operation,
T_C = 25°C**

V_{CE} = 3.0 V, I_{CQ} = 15 mA, pulse width = 577 μs, unless otherwise specified

Frequency = 900 MHz

Parameters	Duty Cycle			
	12.5%	33%	50%	100% = CW
P _{1dB}	22.8	22.7	22.6	22.5
G _{1dB}	13.7	13.6	13.5	13.4
η _c	57.6	58.0	57.3	56.1
P _{3dB}	23.5	23.5	23.5	23.6
G _{3dB}	11.7	11.6	11.5	11.4
η _c	64.5	65.7	66.0	66.0

Frequency = 1900 MHz

Parameters	Duty Cycle			
	12.5%	33%	50%	100% = CW
P _{1dB}	21.7	21.6	21.6	21.6
G _{1dB}	7.4	7.4	7.3	7.3
η _c	51.7	52.0	52.2	50.4
P _{3dB}	24.1	23.9	23.8	23.8
G _{3dB}	5.4	5.5	5.3	5.3
η _c	64.6	64.3	64.5	63.1

AT-38043 Typical Large Signal Impedances

Freq. (MHz)	Bias		Γ_{source}		Γ_{load}	
	V _{CE} (V)	I _{CQ} (mA)	Mag.	Ang.	Mag.	Ang.
450	1.2	15.0	0.873	169.4	0.602	163.5
450	3.0	15.0	0.855	170.3	0.576	148.7
450	4.8	15.0	0.873	176.3	0.593	133.2
800	1.2	15.0	0.886	-166.6	0.607	173.4
800	3.0	15.0	0.896	-170.9	0.505	151.1
800	4.8	15.0	0.899	-167.8	0.530	131.0
900	1.2	15.0	0.861	-160.1	0.576	175.4
900	3.0	15.0	0.865	-164.1	0.500	153.3
900	3.6	15.0	0.897	-165.9	0.528	147.6
900	4.8	15.0	0.877	-165.7	0.479	137.9
900	6.0	15.0	0.872	-166.4	0.494	128.2
1000	1.2	15.0	0.867	-162.9	0.656	171.0
1000	3.0	15.0	0.877	-163.7	0.590	150.5
1000	4.8	15.0	0.881	-162.7	0.575	139.8
1800	1.2	15.0	0.830	-138.2	0.598	-176.1
1800	3.0	15.0	0.863	-145.3	0.633	175.8
1800	4.8	15.0	0.870	-146.2	0.603	164.3
1900	1.2	15.0	0.839	-138.4	0.642	-178.5
1900	3.0	15.0	0.854	-142.0	0.650	172.6
1900	3.6	15.0	0.895	-149.4	0.666	171.1
1900	4.8	15.0	0.842	-138.2	0.610	166.4
1900	6.0	15.0	0.907	-149.3	0.636	156.4
2000	1.2	15.0	0.855	-143.5	0.705	177.5
2000	3.0	15.0	0.866	-140.1	0.673	173.0
2000	4.8	15.0	0.864	-140.0	0.682	163.0

AT-38043 Spice Model Parameters

Die Model

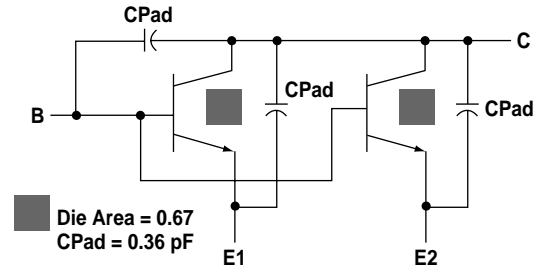

Label	Value	Label	Value
BF	280	NR	0.9886
IKF	299.9	TR	1E-9
ISE	9.9E-11	EG	1.11
NE	2.399	IS	3.598E-15
VAF	33.16	XTI	3
NF	0.9935	CJC	1.02 pF
TF	1.6E-11	VJC	0.4276
XTF	0.006656	MJC	0.2508
VTF	0.02785	XCJC	0.001
ITF	0.001	FC	0.999
PTF	23	CJE	0.98 pF
XTB	0	VJE	0.811
BR	54.61	MJE	0.596
IKR	81	RB	5.435
ISC	8.7E-13	RE	1.30
NC	1.587	RC	0.01
VAR	1.511		

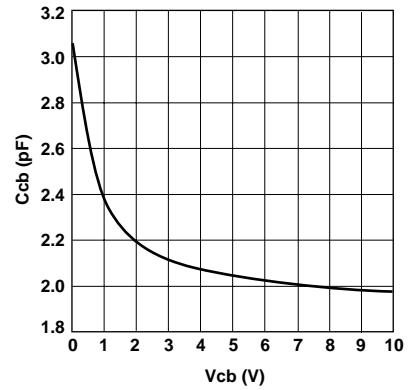
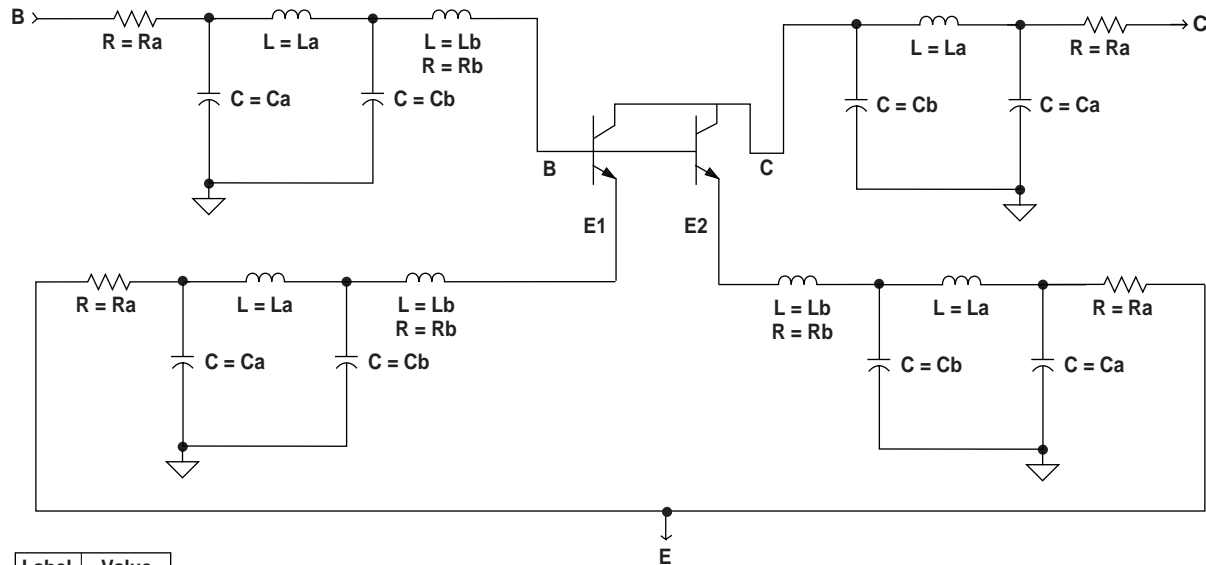

Figure 7. Collector-Base Capacitance vs. Collector-Base Voltage (DC Test).

Packaged Model



Label	Value
Ra	0.1 Ω
Rb	0.2 Ω
La	0.85 nH
Lb	0.25 nH
Ca	0.01 pF
Cb	0.01 pF

AT-38043 Typical Scattering Parameters,Common Emitter, $Z_0 = 50 \Omega$, $V_{CE} = 1.2 \text{ V}$, $I_C = 50 \text{ mA}$, $T_C = +25^\circ\text{C}$

Freq. GHz	S ₁₁		S ₂₁			S ₁₂			S ₂₂	
	Mag	Ang	dB	Mag	Ang	dB	Mag	Ang	Mag	Ang
0.05	0.74	-84	29.4	29.45	147	-28.9	0.036	58	0.79	-48
0.10	0.79	-122	26.2	20.32	132	-26.2	0.049	47	0.64	-73
0.25	0.83	-157	19.5	9.41	129	-24.9	0.057	50	0.52	-80
0.50	0.84	-174	13.7	4.82	146	-24.5	0.060	78	0.51	-42
0.75	0.84	178	10.1	3.21	168	-24.2	0.061	110	0.52	12
0.90	0.84	175	8.6	2.70	-178	-23.9	0.064	130	0.50	45
1.00	0.83	173	7.7	2.43	-169	-23.8	0.065	144	0.51	70
1.25	0.84	169	5.9	1.97	-145	-23.2	0.069	176	0.49	125
1.50	0.84	165	4.2	1.63	-122	-22.8	0.072	-152	0.51	-180
1.75	0.84	161	2.9	1.40	-97	-22.4	0.076	-120	0.52	-120
2.00	0.84	157	1.9	1.24	-73	-21.8	0.081	-89	0.51	-63
2.25	0.85	152	0.7	1.09	-49	-21.5	0.084	-58	0.54	-7
2.50	0.85	148	-0.3	0.97	-24	-21.1	0.088	-27	0.56	55
2.75	0.85	144	-1.1	0.88	1	-20.6	0.093	4	0.55	113
3.00	0.86	141	-2.0	0.80	26	-20.3	0.097	34	0.55	168
3.25	0.86	138	-2.9	0.72	52	-20.0	0.100	64	0.57	-135
3.50	0.87	136	-3.6	0.66	78	-19.6	0.105	94	0.57	-76
3.75	0.87	134	-4.3	0.61	105	-19.2	0.109	124	0.57	-19
4.00	0.88	133	-5.0	0.56	131	-19.0	0.112	153	0.59	37
4.25	0.89	131	-5.8	0.51	158	-18.9	0.114	-178	0.62	95
4.50	0.89	129	-6.5	0.48	-175	-18.7	0.116	-147	0.64	155
4.75	0.90	128	-7.0	0.45	-147	-18.4	0.121	-118	0.65	-147
5.00	0.90	127	-7.6	0.42	-121	-18.2	0.124	-89	0.67	-92

AT-38043 Typical Scattering Parameters,Common Emitter, $Z_0 = 50 \Omega$, $V_{CE} = 3.0 \text{ V}$, $I_C = 50 \text{ mA}$, $T_C = +25^\circ\text{C}$

Freq. GHz	S ₁₁		S ₂₁			S ₁₂			S ₂₂	
	Mag	Ang	dB	Mag	Ang	dB	Mag	Ang	Mag	Ang
0.05	0.75	-66	30.5	33.53	154	-31.2	0.028	65	0.84	-33
0.10	0.78	-106	28.0	25.02	140	-27.7	0.041	53	0.67	-52
0.25	0.81	-149	21.8	12.34	133	-25.8	0.051	54	0.47	-62
0.50	0.82	-169	16.1	6.40	148	-25.3	0.054	80	0.42	-29
0.75	0.82	-179	12.6	4.27	170	-25.0	0.056	112	0.42	22
0.90	0.82	178	11.1	3.59	-177	-24.8	0.058	132	0.41	55
1.00	0.82	176	10.2	3.22	-167	-24.6	0.059	145	0.41	80
1.25	0.82	171	8.3	2.61	-144	-24.1	0.062	178	0.40	135
1.50	0.83	167	6.7	2.16	-120	-23.7	0.065	-150	0.41	-171
1.75	0.83	163	5.3	1.85	-96	-23.2	0.069	-117	0.43	-111
2.00	0.83	159	4.2	1.63	-72	-22.6	0.074	-85	0.43	-53
2.25	0.84	154	3.1	1.43	-48	-22.2	0.077	-55	0.46	2
2.50	0.84	150	2.1	1.27	-23	-21.8	0.081	-23	0.48	64
2.75	0.84	146	1.2	1.15	2	-21.3	0.086	8	0.47	123
3.00	0.85	142	0.3	1.03	27	-20.9	0.090	38	0.48	177
3.25	0.85	139	-0.6	0.93	52	-20.6	0.094	69	0.50	-126
3.50	0.86	137	-1.4	0.85	78	-20.2	0.098	99	0.51	-67
3.75	0.86	135	-2.2	0.78	105	-19.7	0.103	129	0.51	-9
4.00	0.87	134	-2.9	0.71	131	-19.4	0.107	158	0.53	46
4.25	0.88	132	-3.7	0.65	157	-19.2	0.109	-173	0.57	103
4.50	0.89	130	-4.5	0.60	-176	-19.0	0.112	-143	0.60	163
4.75	0.90	129	-5.0	0.56	-149	-18.7	0.117	-113	0.61	-140
5.00	0.90	128	-5.7	0.52	-122	-18.4	0.120	-84	0.62	-85

AT-38043 Typical Scattering Parameters,Common Emitter, $Z_0 = 50 \Omega$, $V_{CE} = 3.6 \text{ V}$, $I_C = 50 \text{ mA}$, $T_C = +25^\circ\text{C}$

Freq. GHz	S_{11}		S_{21}			S_{12}			S_{22}	
	Mag	Ang	dB	Mag	Ang	dB	Mag	Ang	Mag	Ang
0.05	0.75	-65	30.6	33.94	154	-31.3	0.027	65	0.84	-32
0.10	0.78	-104	28.1	25.49	140	-27.8	0.041	54	0.67	-50
0.25	0.81	-148	22.0	12.64	133	-25.9	0.050	54	0.46	-60
0.50	0.82	-169	16.4	6.57	148	-25.4	0.054	80	0.41	-28
0.75	0.82	-178	12.8	4.38	170	-25.1	0.055	112	0.41	23
0.90	0.82	178	11.3	3.68	-177	-24.8	0.057	132	0.40	56
1.00	0.82	176	10.4	3.30	-167	-24.7	0.058	145	0.41	81
1.25	0.82	171	8.5	2.67	-144	-24.2	0.062	178	0.39	136
1.50	0.83	167	6.9	2.21	-120	-23.8	0.065	-150	0.40	-170
1.75	0.83	163	5.5	1.89	-95	-23.3	0.068	-117	0.42	-110
2.00	0.83	159	4.4	1.67	-71	-22.7	0.073	-85	0.42	-52
2.25	0.83	154	3.3	1.46	-48	-22.3	0.077	-54	0.45	2
2.50	0.84	150	2.3	1.30	-23	-21.9	0.081	-23	0.47	65
2.75	0.84	146	1.4	1.18	2	-21.4	0.085	8	0.47	124
3.00	0.84	142	0.5	1.06	27	-21.0	0.090	39	0.47	178
3.25	0.85	140	-0.4	0.95	52	-20.6	0.093	69	0.49	-125
3.50	0.85	137	-1.2	0.87	78	-20.2	0.098	99	0.50	-66
3.75	0.86	135	-2.0	0.80	105	-19.8	0.102	129	0.50	-8
4.00	0.87	134	-2.7	0.73	131	-19.5	0.106	158	0.53	47
4.25	0.88	132	-3.5	0.67	157	-19.3	0.109	-172	0.57	104
4.50	0.89	130	-4.3	0.61	-176	-19.0	0.112	-142	0.59	164
4.75	0.90	129	-4.8	0.57	-149	-18.7	0.116	-113	0.60	-139
5.00	0.90	128	-5.5	0.53	-122	-18.4	0.120	-84	0.62	-84

AT-38043 Typical Scattering Parameters,Common Emitter, $Z_0 = 50 \Omega$, $V_{CE} = 4.8 \text{ V}$, $I_C = 50 \text{ mA}$, $T_C = +25^\circ\text{C}$

Freq. GHz	S_{11}		S_{21}			S_{12}			S_{22}	
	Mag	Ang	dB	Mag	Ang	dB	Mag	Ang	Mag	Ang
0.05	0.77	-63	30.8	34.50	155	-31.6	0.026	66	0.84	-31
0.10	0.79	-102	28.3	26.10	141	-28.0	0.040	55	0.68	-49
0.25	0.81	-147	22.3	13.02	133	-26.0	0.050	54	0.46	-58
0.50	0.81	-168	16.6	6.78	148	-25.5	0.053	80	0.40	-27
0.75	0.81	-178	13.1	4.52	170	-25.2	0.055	112	0.40	24
0.90	0.81	179	11.6	3.79	-176	-24.9	0.057	132	0.39	57
1.00	0.81	176	10.6	3.41	-167	-24.8	0.058	146	0.40	82
1.25	0.82	172	8.8	2.75	-143	-24.3	0.061	178	0.38	137
1.50	0.82	167	7.2	2.28	-120	-23.8	0.064	-149	0.39	-169
1.75	0.82	163	5.8	1.95	-95	-23.4	0.068	-117	0.41	-109
2.00	0.83	159	4.7	1.72	-71	-22.8	0.073	-85	0.41	-51
2.25	0.83	155	3.6	1.51	-47	-22.4	0.076	-54	0.44	3
2.50	0.83	150	2.5	1.34	-22	-21.9	0.080	-22	0.47	66
2.75	0.84	146	1.7	1.21	3	-21.4	0.085	9	0.46	125
3.00	0.84	143	0.7	1.09	27	-21.0	0.089	39	0.46	179
3.25	0.85	140	-0.2	0.98	53	-20.7	0.093	69	0.48	-124
3.50	0.85	138	-1.0	0.89	79	-20.3	0.097	100	0.49	-65
3.75	0.86	136	-1.7	0.82	105	-19.8	0.102	130	0.50	-7
4.00	0.87	134	-2.5	0.75	131	-19.5	0.106	159	0.52	48
4.25	0.88	132	-3.3	0.68	157	-19.3	0.108	-172	0.56	105
4.50	0.89	130	-4.0	0.63	-176	-19.1	0.111	-142	0.58	165
4.75	0.89	129	-4.6	0.59	-149	-18.7	0.116	-112	0.60	-138
5.00	0.90	128	-5.3	0.54	-122	-18.5	0.119	-83	0.61	-83

AT-38043 Typical Scattering Parameters,Common Emitter, $Z_0 = 50 \Omega$, $V_{CE} = 6.0 \text{ V}$, $I_C = 50 \text{ mA}$, $T_C = +25^\circ\text{C}$

Freq. GHz	S ₁₁		S ₂₁			S ₁₂			S ₂₂	
	Mag	Ang	dB	Mag	Ang	dB	Mag	Ang	Mag	Ang
0.05	0.78	-62	30.8	34.85	155	-31.7	0.026	66	0.84	-30
0.10	0.80	-101	28.5	26.47	141	-28.1	0.039	55	0.68	-48
0.25	0.81	-146	22.4	13.26	134	-26.1	0.05	55	0.45	-57
0.50	0.81	-168	16.8	6.90	149	-25.6	0.053	81	0.39	-26
0.75	0.81	177	13.3	4.60	170	-25.3	0.055	112	0.40	25
0.90	0.81	179	11.7	3.86	-176	-25.0	0.056	132	0.38	57
1.00	0.81	177	10.8	3.47	-167	-24.8	0.057	146	0.39	83
1.25	0.82	172	8.9	2.80	-143	-24.3	0.061	178	0.37	138
1.50	0.82	167	7.3	2.32	-120	-23.9	0.064	-149	0.39	-168
1.75	0.82	163	6.0	1.99	-95	-23.4	0.067	-116	0.40	-108
2.00	0.83	159	4.8	1.75	-71	-22.8	0.072	-85	0.40	-50
2.25	0.83	155	3.7	1.53	-47	-22.4	0.076	-54	0.43	4
2.50	0.83	150	2.7	1.36	-22	-22.0	0.08	-22	0.46	66
2.75	0.84	146	1.8	1.23	3	-21.5	0.084	9	0.45	125
3.00	0.84	143	0.9	1.11	27	-21.1	0.088	39	0.45	180
3.25	0.85	140	0	1.00	53	-20.7	0.092	70	0.48	-123
3.50	0.85	138	-0.8	0.91	79	-20.3	0.097	100	0.49	-64
3.75	0.86	136	-1.6	0.83	105	-19.9	0.101	130	0.49	-6
4.00	0.87	134	-2.3	0.76	131	-19.6	0.105	159	0.52	48
4.25	0.88	132	-3.2	0.70	157	-19.4	0.108	-172	0.55	106
4.50	0.89	130	-3.9	0.64	-176	-19.1	0.111	-141	0.58	165
4.75	0.89	129	-4.5	0.60	-149	-18.8	0.115	-112	0.59	-137
5.00	0.90	128	-5.2	0.55	-123	-18.5	0.119	-83	0.61	-83

AT-38043 Typical Performance, $T_C = 25^\circ\text{C}$

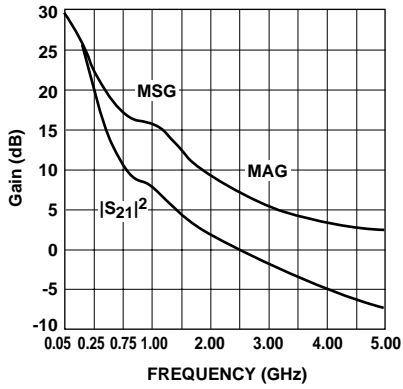

Figure 8. Insertion Power Gain, Maximum Available Gain, and Maximum Stable Gain vs. Frequency
 $V_{CE} = 1.2\text{ V}$, $I_C = 50\text{ mA}$.

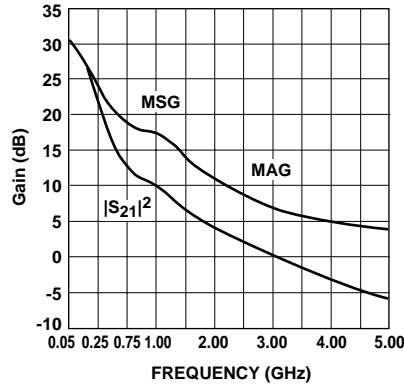

Figure 9. Insertion Power Gain, Maximum Available Gain, and Maximum Stable Gain vs. Frequency
 $V_{CE} = 3.0\text{ V}$, $I_C = 50\text{ mA}$.

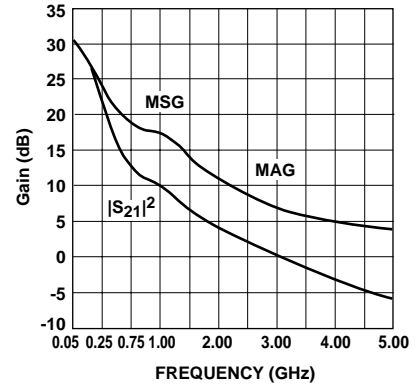

Figure 10. Insertion Power Gain, Maximum Available Gain, and Maximum Stable Gain vs. Frequency
 $V_{CE} = 3.6\text{ V}$, $I_C = 50\text{ mA}$.

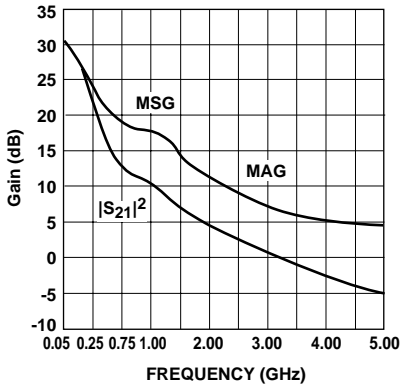

Figure 11. Insertion Power Gain, Maximum Available Gain, and Maximum Stable Gain vs. Frequency
 $V_{CE} = 4.8\text{ V}$, $I_C = 50\text{ mA}$.

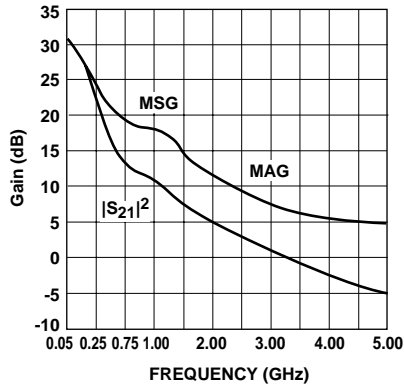

Figure 12. Insertion Power Gain, Maximum Available Gain, and Maximum Stable Gain vs. Frequency
 $V_{CE} = 6.0\text{ V}$, $I_C = 50\text{ mA}$.

Part Number Ordering Information

Part Number	Devices per Reel	Container
AT-38043-TR1	3000	7" Reel
AT-38043-TR2	10,000	13" Reel
AT-38043-BLK	100	Tape

Package Dimensions

SOT-343 (SC-70) Plastic Package

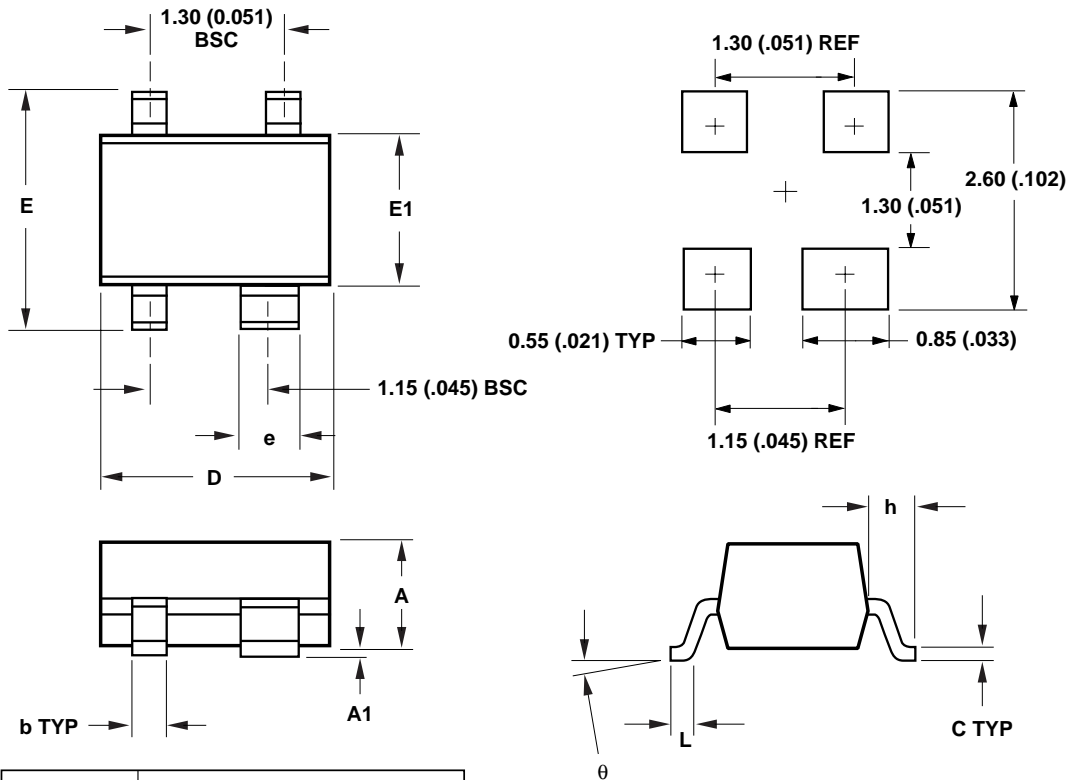

SYMBOL	DIMENSIONS	
	MIN.	MAX.
A	0.80 (0.031)	1.00 (0.039)
A1	0 (0)	0.10 (0.004)
b	0.25 (0.010)	0.35 (0.014)
C	0.10 (0.004)	0.20 (0.008)
D	1.90 (0.075)	2.10 (0.083)
E	2.00 (0.079)	2.20 (0.087)
e	0.55 (0.022)	0.65 (0.025)
h	0.450 TYP (0.018)	
E1	1.15 (0.045)	1.35 (0.053)
L	0.10 (0.004)	0.35 (0.014)
θ	0	10

DIMENSIONS ARE IN MILLIMETERS (INCHES)

Device Orientation

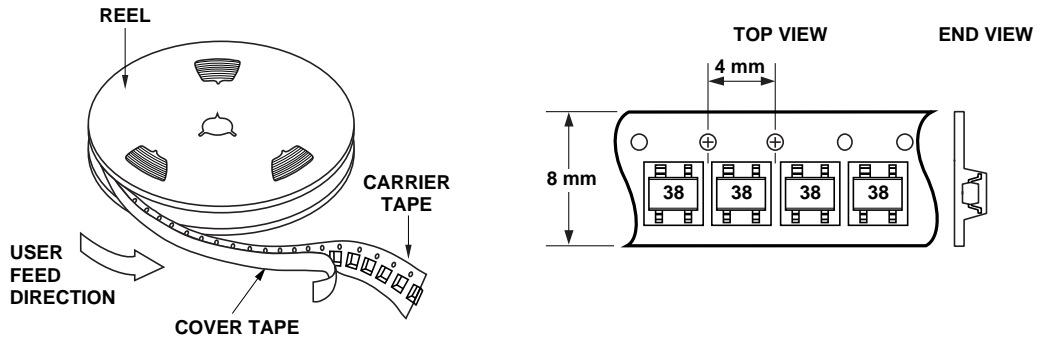

Tape Dimensions For Outline 4T

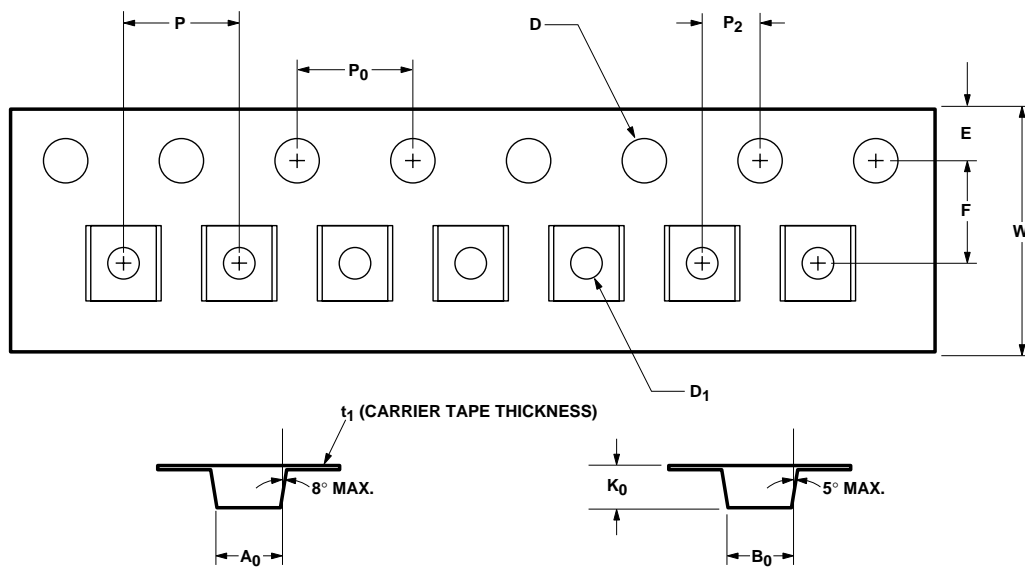

DESCRIPTION		SYMBOL	SIZE (mm)	SIZE (INCHES)
CAVITY	LENGTH	A_0	2.24 ± 0.10	0.088 ± 0.004
	WIDTH	B_0	2.34 ± 0.10	0.092 ± 0.004
	DEPTH	K_0	1.22 ± 0.10	0.048 ± 0.004
	PITCH	P	4.00 ± 0.10	0.157 ± 0.004
	BOTTOM HOLE DIAMETER	D_1	$1.00 + 0.25$	$0.039 + 0.010$
PERFORATION	DIAMETER	D	1.55 ± 0.05	0.061 ± 0.002
	PITCH	P_0	4.00 ± 0.10	0.157 ± 0.004
	POSITION	E	1.75 ± 0.10	0.069 ± 0.004
CARRIER TAPE	WIDTH	W	8.00 ± 0.30	0.315 ± 0.012
	THICKNESS	t_1	0.255 ± 0.013	0.010 ± 0.0005
DISTANCE	CAVITY TO PERFORATION (WIDTH DIRECTION)	F	3.50 ± 0.05	0.138 ± 0.002
	CAVITY TO PERFORATION (LENGTH DIRECTION)	P_2	2.00 ± 0.05	0.079 ± 0.002



Agilent Technologies

Innovating the HP Way

www.semiconductor.agilent.com

Data subject to change.

Copyright © 1999 Agilent Technologies

5966-1275E (11/99)