

**PLEASE CHECK WWW.MOLEX.COM FOR LATEST PART INFORMATION**

**Part Number:** [0473140053](#)  
**Status:** **Active**  
**Description:** 1.00mm (.039") Pitch ExpressCard\* Header, Top Mount, with Push-Push (Card Push) Mechanism, Lead free

**Documents:**

[3D Model](#) [Product Specification PS-47202-001 \(PDF\)](#)  
[Drawing \(PDF\)](#) [RoHS Certificate of Compliance \(PDF\)](#)

**General**

Product Family	Memory Card Sockets
Series	47314
Button Type	Push-Push
Component Type	Header/Socket (Host)
Product Name	ExpressCard*
Type	N/A

**Physical**

Card Detection Switch	No
Circuits (Loaded)	26
Circuits (maximum)	26
Durability (mating cycles max)	10,000
Ejector Button Side	No Ejector Button Present
Entry Angle	Horizontal
Keying to Mating Part	Yes
PCB Locator	Yes
PCB Mounting Side	Normal
PCB Retention	Yes
Packaging Type	Embossed Tape on Reel
Pitch - Mating Interface (in)	0.039 In
Pitch - Mating Interface (mm)	1.00 mm
Pitch - Term. Interface (in)	0.039 In
Pitch - Term. Interface (mm)	1.00 mm
Ports	1
Temperature Range - Operating	0°C to +55°C

**Electrical**

Current - Maximum per Contact	0.75A
Shielded	No
Voltage - Maximum	3.3V DC
Voltage Key	N/A

**Material Info**

**Reference - Drawing Numbers**

Packaging Specification	PK-47314-003
Product Specification	PS-47202-001
Sales Drawing	SD-47314-002

\* ExpressCard is trademark, or registered trademark of PCMCIA

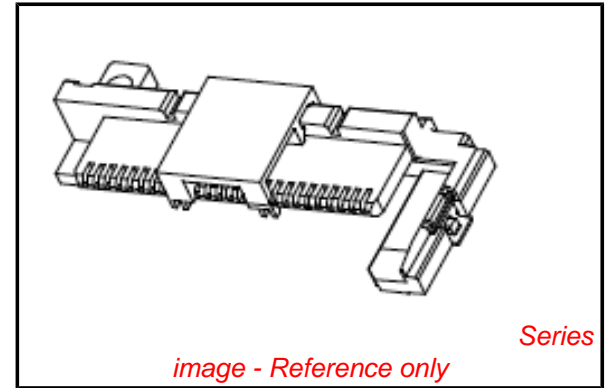

**EU RoHS**

**ELV and RoHS  
Compliant**  
**REACH SVHC**  
 Not Reviewed  
**Halogen-Free  
Status**

**China RoHS**



**Need more information on product  
environmental compliance?**

Email [productcompliance@molex.com](mailto:productcompliance@molex.com)  
 For a multiple part number RoHS Certificate of  
 Compliance, [click here](#)

Please visit the [Contact Us](#) section for any  
 non-product compliance questions.

**Search Parts in this Series**

[47314Series](#)

**Mates With**

[ExpressCard\\* Module](#)

**Use With**

[473149054 Card Ejector](#)

10 9 8 7 6 5 4 3 2 1

F

E

D

C

B

A

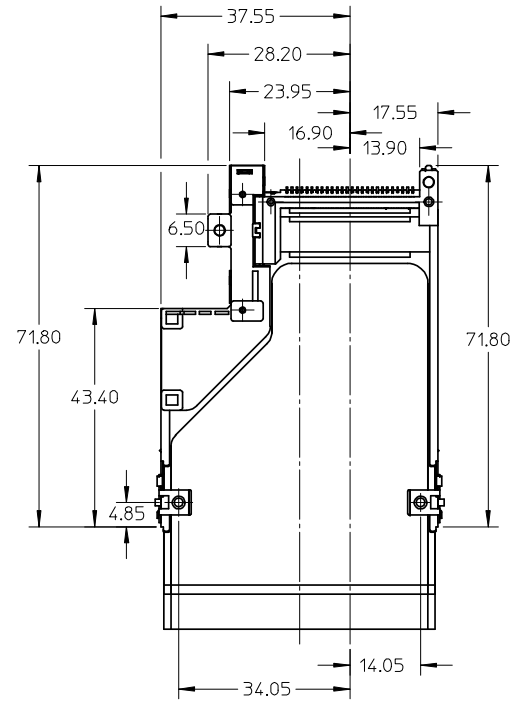
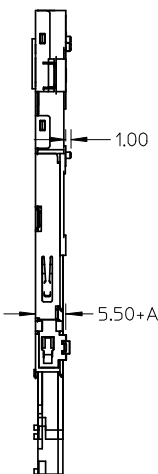
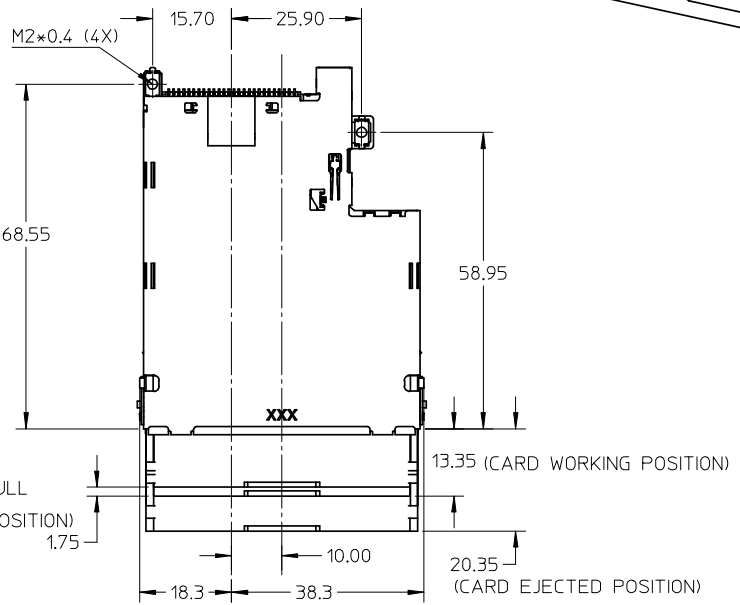
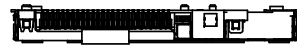
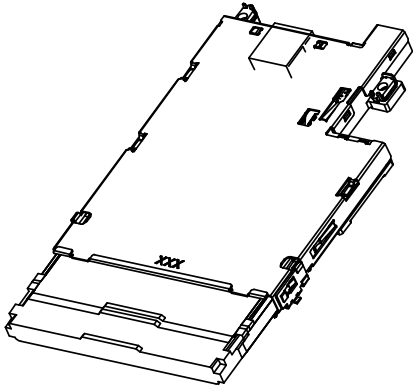

- NOTES:
- COMPONENT:  
HEADER: SHEET 2  
EJECTOR: SHEET 3
  - PCB LAYOUT PLEASE REFER TO SHEET 4;
  - COPLANARTY OF HEADER FOR SMT SOLDER TAILS TO BE 0.10mm MAXIMUM;
  - PRODUCT SPECIFICATION PLEASE REFER TO PS-47202-001;
  - SCREW FASTENING TORQUE: 1.5kgf-cm MAXIMUM.
  - TRUE POSITION IS 0.15mm MAXIMUM BETWEEN SOLDER TAILS;
  - NON-REFLOW PROCESS FOR CARD SLOT;
  - THE PART COMPLIANT TO RoHS DIRECTIVE 2002/95/EC AND ELV 2000/53/EC.

RELEASE IEC NO: SH2008-0538 DRW: F YANG05 CH/KD: APPR: HWANG 2008/04/30 2008/05/19 2008/05/26	QUALITY SYMBOLS ▽=0 ◻=0	GENERAL TOLERANCES (UNLESS SPECIFIED)		DIMENSION STYLE MM ONLY		SCALE 1:1	DESIGN UNITS METRIC	THIRD ANGLE PROJECTION			
		4 PLACES ± --- ± ---	3 PLACES ± --- ± ---	2 PLACES ± 0.25 ± ---	1 PLACE ± 0.3 ± ---	ANGULAR ± 3 °	DRAWN BY R. BIAN	DATE 2007/06/12	TITLE EXPRESSCARD TOP MOUNT WITH PUSH-PUSH MECHANISM (CARD PUSH)		
		DRAFT WHERE APPLICABLE MUST REMAIN WITHIN DIMENSIONS					APPROVED BY JNCHEN	DATE 2007/06/12	MOLEX INCORPORATED		
		MATERIAL NO. N/A					DOCUMENT NO. SD-47314-002			SHEET NO. 1 OF 4	

9 8 7 6 5 4 3 2 1

NOTES:

1. MATERIAL:

HOUSING: LIQUID CRYSTAL POLYMER, UL94 V-0;  
 TERMINAL: PHOSPHOR BRONZE;  
 FITTING NAIL: PHOSPHOR BRONZE;

2. FINISH:

TERMINAL: SELECTIVE GOLD(Au) IN CONTACT AREA.  
 THICKNESS: 0.15 MICROMETER MINIMUM  
 SELECTIVE PURE TIN IN SOLDER TAIL AREA.  
 THICKNESS: 1.5 MICROMETER MINIMUM  
 UNDERPLATING : NICKEL(Ni) OVERALL

3. COPLANARITY AT SOLDER TAIL TO BE 0.10mm MAXIMUM;

4. APPLICABLE EJECTOR PLEASE SEE TABLE;

5. PRODUCT SPECIFICATION REFERS TO PS-47202-001;

6. THE PART COMPLIANT TO RoHS DIRECTIVE 2002/95/EC AND ELV 2000/53/EC.

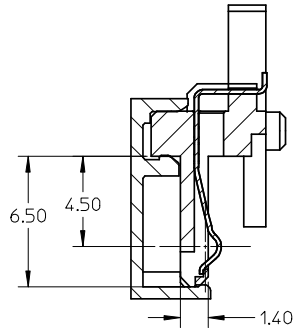
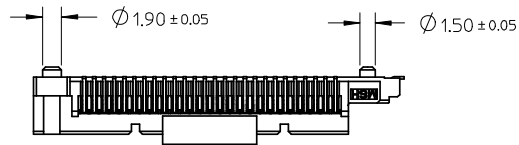
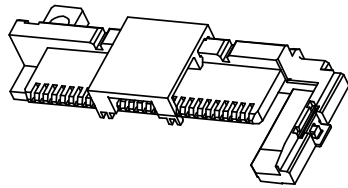

SECTION Z-Z  
 SCALE:4:1

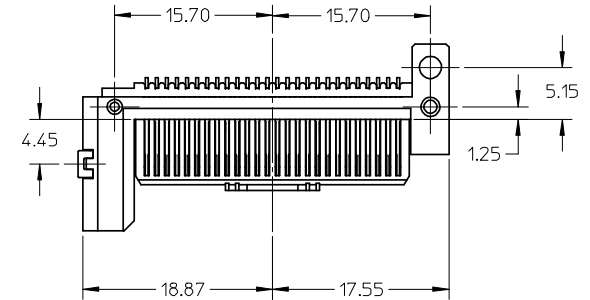
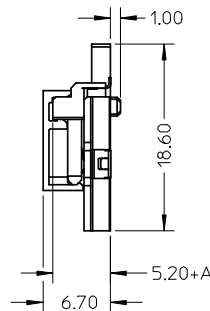
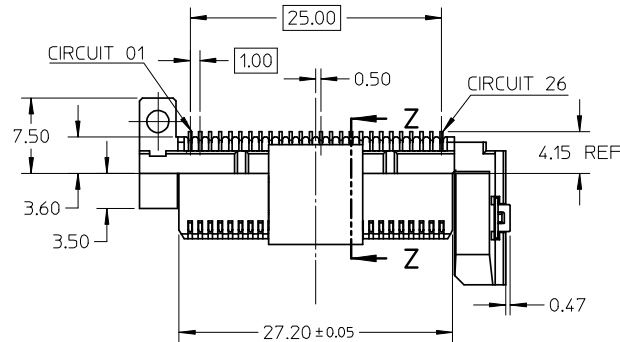

RELEASE EC NO: SH2008-0538 DRW: F YANG05 CHKD: 2008/05/19 APPR: HWANG 2008/05/26	QUALITY SYMBOLS ▽=0 ▽=0	GENERAL TOLERANCES (UNLESS SPECIFIED)		DIMENSION STYLE MM ONLY		SCALE NTS	DESIGN UNITS METRIC	THIRD ANGLE PROJECTION	
		4 PLACES	± ---	± ---	mm	INCH	DRAWN BY R. BIAN	DATE 2007/06/12	TITLE EXPRESSCARD TOP MOUNT WITH PUSH-PUSH MECHANISM (CARD PUSH)
		3 PLACES	± ---	± ---			CHECKED BY HWANG	DATE 2007/06/12	MOLEX INCORPORATED
		2 PLACES	± 0.25	± ---			APPROVED BY JNCHEN	DATE 2007/06/12	
1 PLACE	± 0.3	± ---			MATERIAL NO. SEE TABLE		DOCUMENT NO. SD-47314-002	SHEET NO. 2 OF 4	
DRAFT WHERE APPLICABLE MUST REMAIN WITHIN DIMENSIONS		ANGULAR ± 3 °		SIZE A3		THIS DRAWING CONTAINS INFORMATION THAT IS PROPRIETARY TO MOLEX INCORPORATED AND SHOULD NOT BE USED WITHOUT WRITTEN PERMISSION			

47314-0053	0.50 MM	47314-9054
PART NO.	A (STAND OFF HEIGHT)	APPLICABLE EJECTOR

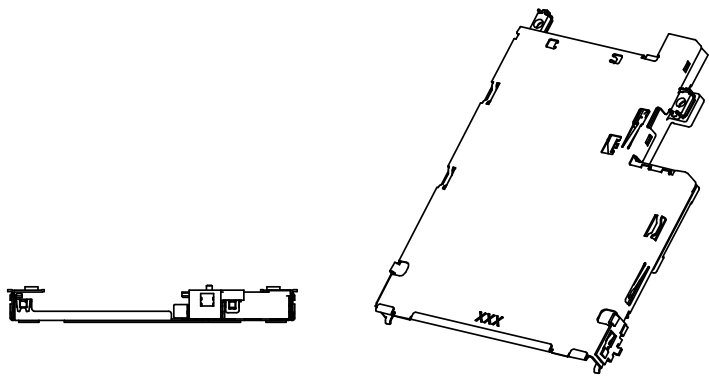

NOTES:

1. MATERIAL:

- SHELL: STAINLESS STEEL
- STAND OFF: STAINLESS STEEL
- NUT: STAINLESS STEEL
- COIL SPRING: PIANO WIRE
- CAM SLIDER: NYLON46 UL94 V-0
- CAM SLIDER HOUSING: NYLON46 UL94 V-0
- CAM PIN: STAINLESS STEEL
- STOPPER: STAINLESS STEEL

- 2. THIS SLOT TO BE COMPATIBLE BOTH 34mm CARD AND 54mm CARD;
- 3. THE EJECTOR MECHANISM TO BE ASSEMBLED BASE ON 34mm CARD CENTER LINE;
- 4. APPLICABLE HEADER PLEASE SEE TABLE;
- 5. PRODUCT SPECIFICATION PLEASE REFER TO PS-47202-001;
- 6. THE PART COMPLIANT TO RoHS DIRECTIVE 2002/95/EC AND ELV 2000/53/EC

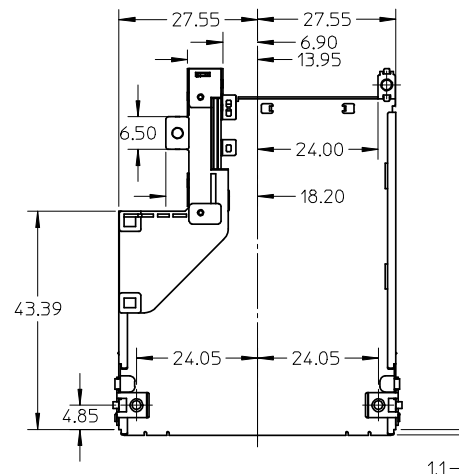
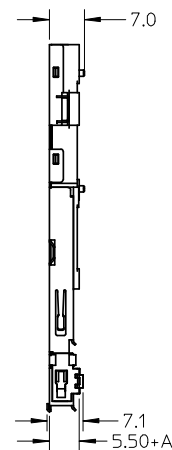
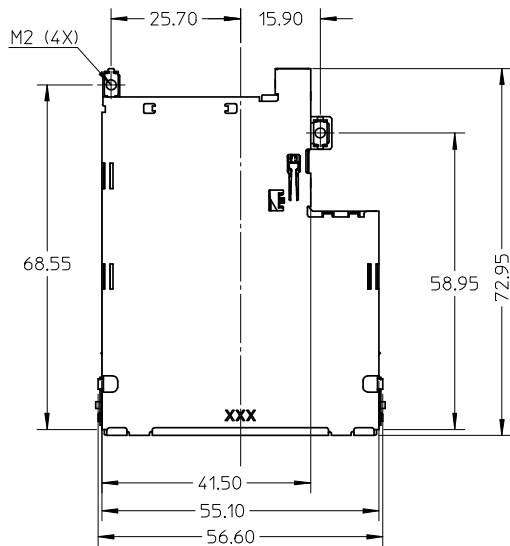

RELEASE EC NO: SHZ008-0538 DRW: NYANG05 CHKD: HWWANG APPR: HWWANG	2008/04/30 2008/05/19 2008/05/26	DESCRIPTION A	QUALITY SYMBOLS	GENERAL TOLERANCES (UNLESS SPECIFIED)	DIMENSION STYLE	SCALE	DESIGN UNITS	THIRD ANGLE PROJECTION
			$\nabla = 0$ $\nabla C = 0$	mm INCH	MM ONLY	NTS	METRIC	
			4 PLACES $\pm$ --- $\pm$ --- 3 PLACES $\pm$ --- $\pm$ --- 2 PLACES $\pm$ 0.25 $\pm$ --- 1 PLACE $\pm$ 0.3 $\pm$ --- ANGULAR $\pm$ 3 °	DRAWN BY: R. BIAN CHECKED BY: HWWANG APPROVED BY: JNCHEN DATE: 2007/06/12 DATE: 2007/06/12 DATE: 2007/06/12	MATERIAL NO. SEE TABLE	TITLE EXPRESSCARD TOP MOUNT WITH PUSH-PUSH MECHANISM (CARD PUSH)	MOLEX INCORPORATED	
			DRAFT WHERE APPLICABLE MUST REMAIN WITHIN DIMENSIONS	THIS DRAWING CONTAINS INFORMATION THAT IS PROPRIETARY TO MOLEX INCORPORATED AND SHOULD NOT BE USED WITHOUT WRITTEN PERMISSION	DOCUMENT NO. SD-47314-002	SHEET NO. 3 OF 4		

47314-9054	0.50 MM	47314-0053
PART NO.	A (STAND OFF HEIGHT)	APPLICABLE HEADER

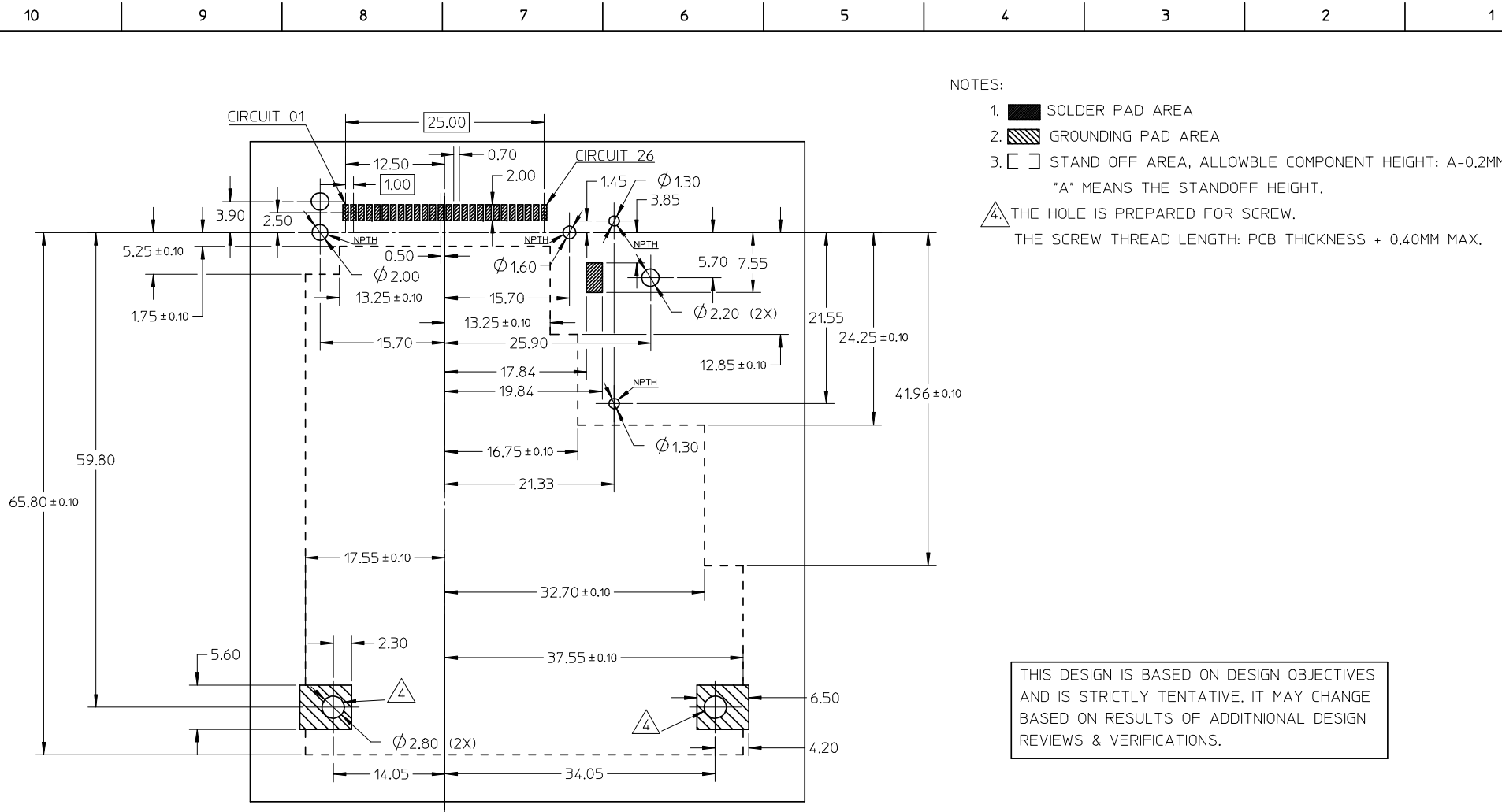

NOTES:

1. SOLDER PAD AREA
2. GROUNDING PAD AREA
3. STAND OFF AREA, ALLOWBLE COMPONENT HEIGHT: A-0.2MM, "A" MEANS THE STANDOFF HEIGHT.
4. THE HOLE IS PREPARED FOR SCREW.  
THE SCREW THREAD LENGTH: PCB THICKNESS + 0.40MM MAX.

THIS DESIGN IS BASED ON DESIGN OBJECTIVES AND IS STRICTLY TENTATIVE. IT MAY CHANGE BASED ON RESULTS OF ADDITNIONAL DESIGN REVIEWS & VERIFICATIONS.

RECOMMENDED PCB LAYOUT

RELEASE EC NO: SH2008-0538 DRWN: FYANG05 CHKD: APPR: HWANG	2008/04/30 2008/05/19 2008/05/26	DESCRIPTION REV	QUALITY SYMBOLS	GENERAL TOLERANCES (UNLESS SPECIFIED)	DIMENSION STYLE	SCALE	DESIGN UNITS	THIRD ANGLE PROJECTION	
			$\nabla = 0$ $\square = 0$	mm    INCH 4 PLACES ± --- ± --- 3 PLACES ± --- ± --- 2 PLACES ± 0.25 ± --- 1 PLACE ± 0.3 ± --- ANGULAR ± 3 °	MM ONLY	NTS	METRIC		
				DRAFT WHERE APPLICABLE MUST REMAIN WITHIN DIMENSIONS	DRAWN BY: R. B IAN    DATE: 2007/06/12 CHECKED BY: HWANG    DATE: 2007/06/12 APPROVED BY: JNCHEN    DATE: 2007/06/12	TITLE	EXPRESSCARD TOP MOUNT WITH PUSH-PUSH MECHANISM (CARD PUSH)		
					MATERIAL NO. N/A SIZE: A3	MOLEX INCORPORATED DOCUMENT NO. SD-47314-002 SHEET NO. 4 OF 4			