



# AS1129

## 500mA Low Dropout Voltage Regulator (PRELIMINARY INFORMATION)

### FEATURES

- 1% Output Accuracy 2.5V, 3.3V, 5V, @ 500mA Output
- Very Low Quiescent Current
- 0.4V Dropout Voltage
- Extremely Tight Load and Line Regulation
- Current & Thermal Limiting
- Logic-Controlled Electronic Shutdown
- Reverse Battery Protection
- Output Programmable From 1.24 To 20V
- Equivalent Replacement For LT1129

### APPLICATIONS

- Battery Powered Systems
- Cordless Telephones
- Radio Control Systems
- Portable/Palm Top/Notebook Computers
- Portable Consumer Equipment
- Portable Instrumentation
- Bar Code Scanners
- SMPS Post-Regulator
- Voltage Reference
- Automotive Electronics

### PRODUCT DESCRIPTION

The AS1129 is a low power voltage regulator. This device is an excellent choice for use in battery-powered applications such as cordless telephones, radio control systems, and portable computers. The AS1129 features very low quiescent current and very low dropout voltage of 0.4 volts. This includes a tight initial tolerance of  $\pm 1\%$  max, and very low output temperature coefficient, making the AS1129 useful as a low-power voltage reference.

The error flag output feature is used as power-on reset for warning of a low output voltage, due to falling voltage input of batteries. The AS1129 is offered TO-92, SOT-223, TO-220, TO-252 and TO-263 in 3 & 5 leads.

### ORDERING INFORMATION

TO-92	SOT-223 3-PIN	TO-220 3-PIN	TO-263 3/5-PIN	TO-263 5-PIN	TO-252 3/5-PIN	Oper. Temp. Range
AS1129N-X	AS1129M3-X	AS1129U-X	AS1129T-X	AS1129T3-X	AS1129R-X	-40°C to +125°C

X= Output Voltage (2.5V, 3.3V or 5.0V)  
Consult factory for other fixed voltages.

### PIN CONNECTIONS

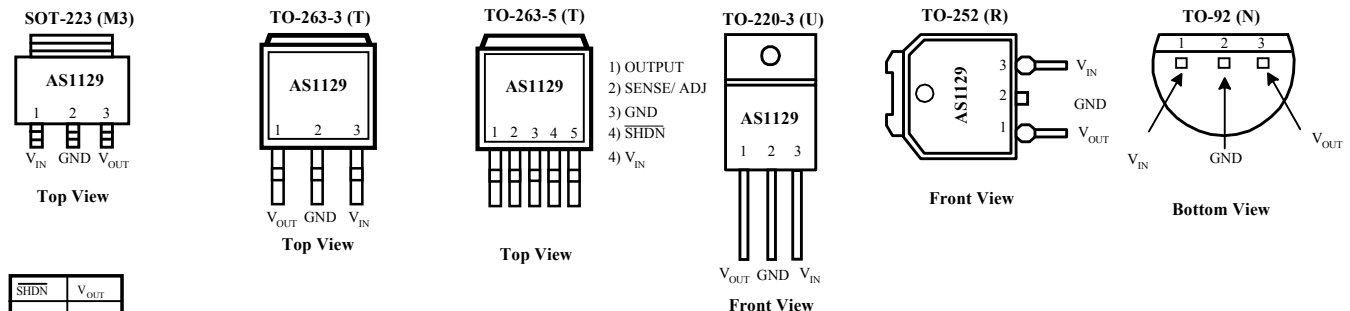

SHDN	$V_{OUT}$
<0.25V	OFF
>2.8V	ON
NC	ON

## ABSOLUTE MAXIMUM RATINGS

Power Dissipation..... Internally Limited  
 Lead Temp. (Soldering, 5 Seconds)..... 260°C  
 Storage Temperature Range..... -65°C to + 150°C  
 Operating Junction Temperature Range  
 AS1129..... -40°C to + 125°C

Maximum Input Supply Voltage..... +20V  
 Shutdown Input Voltage ..... -0.6V to 6.5V

## ELECTRICAL CHARACTERISTICS at $V_S = \pm 15V$ , $T_A = 25^\circ C$ , unless otherwise specified. **Boldface** applies over the full operating temperature range.

PARAMETER	CONDITIONS (Note 2)	Typ.	AS1129		UNITS
			Min	Max	
<b>2.5V Version</b>					
Output Voltage	$1mA \leq I_L \leq 500mA$	<b>2.5</b>	2.475	2.525	V
Reverse Output Current	$V_{OUT} = 2.5V, V_{IN} = 0V$	16		25	$\mu A$
<b>3.3V Version</b>					
Output Voltage	$1mA \leq I_L \leq 500mA$	3.3	3.267	3.333	V
Reverse Output Current	$V_{OUT} = 3.3V, V_{IN} = 0V$	16		25	$\mu A$
<b>5V Version</b>					
Output Voltage	$1mA \leq I_L \leq 500mA$	5.0	4.950	5.050	V
Reverse Output Current	$V_{OUT} = 5.0V, V_{IN} = 0V$	16		25	$\mu A$
<b>All Voltage Options</b>					
Output Voltage Temperature Coefficient	(Note 1)	20		<b>100</b>	ppm/°C
Line Regulation (Note 3)	$6V \leq V_{IN} \leq 20V$ (Note 4)	1.5		<b>10</b>	%max
Load Regulation (Note 3)	$I_L = 1$ to 500mA $I_L = 0.1$ to 1mA	0.04		0.20 <b>0.30</b>	%max
Dropout Voltage (Note 5)	$I_L = 1mA$	0.13		0.16 <b>0.25</b>	V
	$I_L = 500mA$	0.42		0.55 <b>0.70</b>	
Ground Current	$I_L = 1mA$	<b>100</b>		<b>150</b>	$\mu A$
	$I_L = 10mA$	<b>350</b>		<b>500</b>	
	$I_L = 50mA$	<b>1.5</b>		<b>2.5</b>	mA
	$I_L = 100mA$	<b>4.0</b>		<b>7.0</b>	
	$I_L = 500mA$	<b>7</b>		<b>14</b>	
Current Limit	$V_{OUT} = 0$	200		<b>500</b>	mA
Ripple Rejection	$V_{IN} - V_{OUT} 1V$ (Avg), $V_{RIPPLE} = 0.5V_{p-p}$ fripple = 120Hz, $I_{LOAD} = 500mA$ , $T_J = 25^\circ C$	58	50		dB
Input Reverse Leakage Current	$V_{IN} = -20V, V_{OUT} = 0V$			1.0	mA

**Note 1:** Output or reference voltage temperature coefficients defined as the worst-case voltage change divided by the total temperature range.

**Note 2:** Unless otherwise specified all limits are guaranteed for  $T_J = 25^\circ\text{C}$ ,  $V_{IN} = 6\text{V}$ ,  $I_L = 100\mu\text{A}$  and  $C_L = 1\mu\text{F}$ . Additional conditions for the 8-pin versions are feedback tied to 5V tap and output tied to output sense ( $V_{OUT} = 5\text{V}$ ) and  $V_{SHUTDOWN} \leq 0.8\text{V}$ .

**Note 3:** Regulation is measured at constant junction temperature, using pulse testing with a low duty cycle. Changes in output voltage due to heating effects are covered under the specification for thermal regulation.

**Note 4:** Line regulation for the AS1129 is tested at  $150^\circ\text{C}$  for  $I_L = 1\text{mA}$ . For  $I_L = 100\mu\text{A}$  and  $T_J = 125^\circ\text{C}$ , line regulation is guaranteed by design to 0.2%. See typical performance characteristics for line regulation versus temperature and load current.

**Note 5:** Dropout voltage is defined as the input to output differential at which the output voltage drops 100 mV below its nominal value measured at 1V differential at very low values of programmed output voltage, the minimum input supply voltage of 2V (2.3V over temperature) must be taken into account.

**Note 6:** Comparator thresholds are expressed in terms of a voltage differential at the feedback terminal below the nominal reference voltage measured at 6V input. To express these thresholds in terms of output voltage change, multiply by the error amplifier gain  $= V_{OUT}/V_{REF} = (R1 + R2)/R2$ . For example, at a programmed output voltage of 5V, the Error output is guaranteed to go low when the output drops by  $95\text{mV} \times 5\text{V}/1.235 = 384\text{mV}$ . Thresholds remain constant as a percent of  $V_{OUT}$  as  $V_{OUT}$  is varied, with the dropout warning occurring at typically 5% below nominal, 7.5% guaranteed.

## APPLICATION HINTS

### EXTERNAL CAPACITORS

The stability of the AS1129 requires a  $2.2\mu\text{F}$  or greater capacitor between output and ground. Oscillation could occur without this capacitor. Most types of tantalum or aluminum electrolytic works fine here. For operations of below  $-25^\circ\text{C}$  solid tantalum is recommended since the many aluminum types have electrolytes the freeze at about  $-30^\circ\text{C}$ . The ESR of about  $5\Omega$  or less and resonant frequency above  $500\text{kHz}$  are the most important parameters in the value of the capacitor. The capacitor value can be increased without limit.

At lower values of output current, less output capacitance is required for stability. For the currents below 10mA the value of the capacitor can be reduced to  $0.5\mu\text{F}$  and  $0.15\mu\text{F}$  for 1mA. More output capacitance needed for the 8-pin version at voltages below 5V since it runs the error amplifier at lower gain. At worst case  $5\mu\text{F}$  or greater must be used for the condition of 250mA load at 1.23V output.

The AS1129, unlike other low dropout regulators will remain stable and in regulation with no load in addition to the internal voltage divider. This feature is especially important in application like CMOS RAM keep-alive. When setting the output voltage of the AS1129, a minimum load of 10mA is recommended.

If there is more than 10 inches of wire between the input and the AC filter capacitor or if a battery is used as the input then a  $0.1\mu\text{F}$  tantalum or aluminum electrolytic capacitor should be placed from the input to the ground.

Instability can occur if there is stray capacitance to the AS1129 feedback terminal (pin 7). This could cause more problems when using a higher value of external resistors to set the output voltage.

This problem can be fixed by adding a  $100\text{pF}$  capacitor between output and feedback and increasing the output capacitor to at least  $3.3\mu\text{F}$ .

### ERROR DETECTION COMPARATOR OUTPUT

The Comparator produces a logic low output whenever the AS1129 output falls out of regulation by more than around 5%. This is around 60mV offset divided by the 1.235 reference voltage. This trip level remains 5% below normal regardless of the programmed output voltage of the regulator. Figure 1 shows the timing diagram depicting the ERROR signal and the regulator output voltage as the AS1129 input is ramped up and down. The ERROR signal becomes low at around 1.3V input, and goes high around 5V input (input voltage at which  $V_{out} = 4.75$ ). Since the AS1129's dropout voltage is load dependent, the input voltage trip point (around 5V) will vary with the load current. The output voltage trip point (approx. 4.75V) does not vary with load.

The error comparator has an open-collector output, which requires an external pull-up resistor. Depending on the system requirements the resistor may be returned to 5V output or other supply voltage. In determining the value of this resistor, note that the output is rated to sink  $400\mu\text{A}$ , this value adds to battery drain in a low battery condition. Suggested values range from 100K to  $1\text{M}\Omega$ . If the output is unused this resistor is not required.

### PROGRAMMING THE OUTPUT VOLTAGE OF AS1129

The AS1129 may be pin-strapped for 5V using its internal voltage divider by tying Pin 1 (output) to Pin 2 (sense) and Pin 7 (feedback) to Pin 6 (5V Tap).

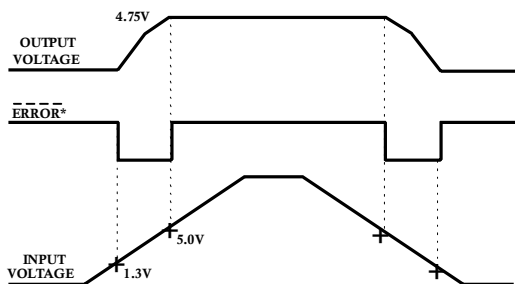

\* See Application Information.

Figure 1. ERROR Output Timing

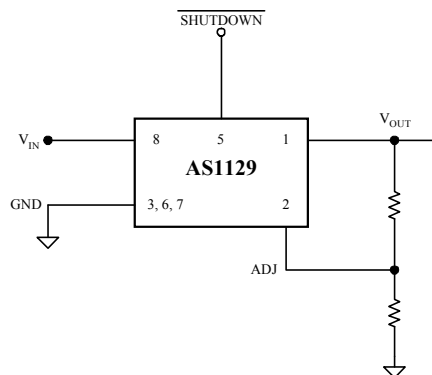

Figure .2. Adjustable Voltage Regulator

Also, it may be programmed for any output voltage between its 1.235V reference and its 30V maximum rating. As seen in Figure 2, an external pair of resistors is required.

Refer to the below equation for the programming of the output voltage:

$$V_{OUT} = V_{REF} \times (1 + R_1 / R_2) + I_{FB}R_1$$

The  $V_{REF}$  is 1.235 and  $I_{FB}$  is the feedback bias current, nominally -20nA. The minimum recommended load current of 1  $\mu$ A forces an upper limit of 1.2 M $\Omega$  on value of  $R_2$ . If no load is presented the  $I_{FB}$  produces an error of typically 2% in  $V_{OUT}$ , which may be eliminated at room temperature by trimming  $R_1$ . To improve the accuracy choose the value of  $R_2 = 100k$  this reduces the error by 0.17% and increases the resistor program current by 12 $\mu$ A. Since the AS1129 typically draws 60  $\mu$ A at no load with Pin 2 open-circuited this is a small price to pay

## REDUCING OUTPUT NOISE

It may be an advantage to reduce the AC noise present at the output. One way is to reduce the regulator bandwidth by increasing the size of the output capacitor. This is the only way that noise can be reduced on the 3 lead AS1129 but is relatively inefficient, as increasing the capacitor from 1 $\mu$ F to 220 $\mu$ F only decreases the noise from 430 $\mu$ V to 160 $\mu$ V Vrms for a 100kHz bandwidth at 5V output.

Noise could also be reduced fourfold by a bypass capacitor across  $R_1$ , since it reduces the high frequency gain from 4 to unity. Pick

$$C_{BYPASS} \cong 1 / 2\pi R_1 \times 200 \text{ Hz}$$

or choose 0.01 $\mu$ F. When doing this, the output capacitor must be increased to 3.3 $\mu$ F to maintain stability. These changes reduce the output noise from 430 $\mu$ V to 100 $\mu$ V Vrms for a 100kHz bandwidth at 5V output. With the bypass capacitor added, noise no longer scales with output voltage so that improvements are more dramatic at higher output voltages.

## HEAT SINK REQUIREMENTS

Depending on the maximum ambient temperature and maximum power dissipation a heat sink may be required with the AS1129. The junction temperature range has to be within the range specified under Absolute Maximum Ratings under all possible operating conditions. To find out if a heat sink is required, the maximum power dissipation of the device needs to be calculated. This is the maximum specific AC voltage that must be taken into consideration at input. Figure 3 shows the condition and power dissipation which should be calculated with the following formula:

$$P_{TOTAL} = (V_{IN} - 5) * I_L + (V_{IN}) I_G$$

Next step is to calculate the temperature rise  $T_R$  (max).  $T_J$  (max) maximum allowable junction temperature,  $T_A$  (max) maximum ambient temperature :

$$T_R(\text{max}) = T_J(\text{max}) - T_A(\text{max})$$

Junction to ambient thermal resistance  $\theta_{(J-A)}$  can be calculated after determining of  $P_{TOTAL}$  &  $T_R$  (max):

$$\theta_{(J-A)} = T_R(\text{max}) / P_{(\text{max})}$$

If the  $\theta_{(J-A)}$  is 60 $^{\circ}$ C/W or higher, the device could be operated without a heat sink. If the value is below 60 $^{\circ}$ C/W then the heat sink is required and the thermal resistance of the heat sink can be calculated by the following formula,  $\theta_{(J-C)}$  junction to case,  $\theta_{(C-H)}$  case to heat sink,  $\theta_{(H-A)}$  heat sink to ambient:

$$\theta_{(J-A)} = \theta_{(J-C)} + \theta_{(C-H)} + \theta_{(H-A)}$$

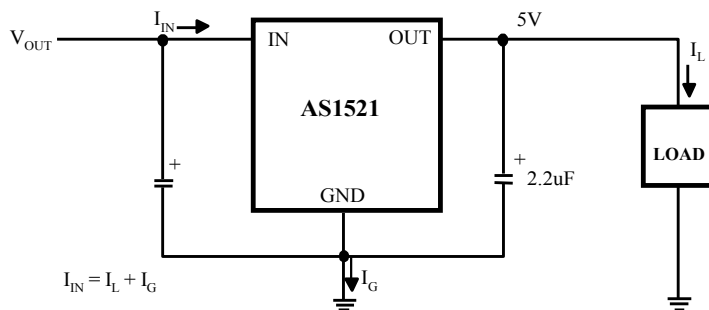

Figure 3. Fixed +5V Regulator Circuit