

YAMAHA[®] LSI

YMU251XX SERIES

FM MUSIC 2

■ Outline

The YMU251XX(FM MUSIC2) series is a product line of ICs designed for automatic music performance employing FM sound source.

Keeping the compatibility of timbre and melody data with YM64AXX(FM MUSIC) series, new functions of low voltage power driven and output signal to control external devices are added to the YMU251XX series.

In addition, 8 melodies in a maximum of 991 steps are stored in the chip.

A built-in DAC enables the high-quality FM sound automatic music performance system by simplified circuits.

■ Features

- Realistic sounds by 2 operator FM sound source.
- Timbre and melody data upper compatible with the YM64AXX(FM MUSIC) series.
- Number of simultaneous sounds...Up to 4 sounds(4 independent timbres possible).
- Melody data...8 melodies(or 8 phrases) are selectable within up to 991 steps.
- Control signal...Output signal to control external devices is available in synchronization with the melody.
- Timbre data...Up to 4 timbres can be set for 1 melody(or 1 phrase).
Maximum of 8 timbre presets for 8 melodies.
- Level Hold or One Shot can be selected by the pin for start-up. (Pin selectable)
- Performance mode...Repeated performance of all melodies or specified melody is possible.
- A maximum of 16 times repeated performance is set by the JUMP and END command.
For One Shot mode, it can be also set by reading terminal data during performance.
- Built-in DAC and crystal oscillator circuit
- CMOS low power consumption (0.9 μ A or less during stand by when 3V power supply)
- 16-pin plastic DIP package

Note: Specifications are subject to change without notice.

YAMAHA CORPORATION

■ 9945524 0002202 067 ■

YMU251XX SERIES

CATALOG No.:

1991.02

■Block diagram

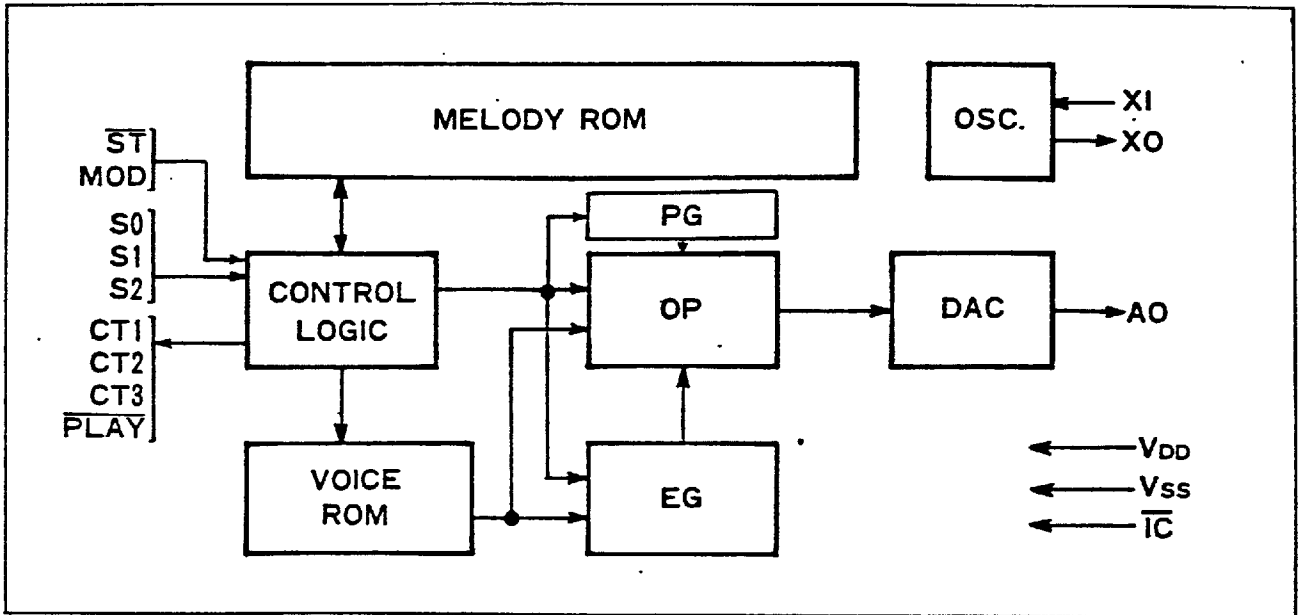

■Pin configuration

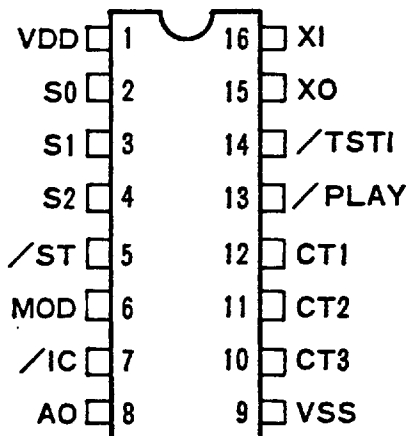

■Pin description

No	Pin	I/O	Function
1	VDD	I	Power supply
2	S0 *1	I	Input for melody (phrase) selection
3	S1 *1	I	Input for melody (phrase) selection
4	S2 *1	I	Input for melody (phrase) selection
5	/ST *	I	Performance start Performance starts when /ST terminal changes from "H" to "L".
6	MOD *1	I	Selection of performance mode; "L" for Level Hold start "H" for One Shot start
7	/IC *	I	Initial clear terminal Initializing when "L".
8	AO	O	Analogue output
9	VSS	I	GND
10	CT3	O	Control signal output
11	CT2	O	Control signal output
12	CT1	O	Control signal output
13	/PLAY	O	Performance status output, "L" during performance.
14	/TSTI *	I	LSI test terminal (OPEN or connected to VDD)
15	XO	O	Crystal oscillator (clock) output
16	XI	I	Crystal oscillator (clock) input

* ; pulled-up terminal.

*1; pulled-up terminal, (disconnected during stand-by.)

■Function

Sound source

Sound generation method : FM sound source by 2 operators
 No. of sounds : Simultaneous generation of 4 sounds / 4 timbres
 Sound range : 3 octaves (C2# to C5)

Timbre parameters

Multiple : 1/2, 1, 2, 3, 4, 5, 6, 7 steps
 Total level : 0 to -47.25dB, 64 steps
 Feed back : Self-feedback modulation, 8 steps
 Vibrate : ON/OFF (Setting for each note is possible)
 EG type : Continued / decay
 Attack rate : 0 ms to 38s, 16 steps
 Decay rate : 4.5ms to 73s, 16 steps
 Sustain level : 0 to -45 dB, 16 steps
 Release rate : 4.5ms to 73s, 16 steps
 Sustain : ON/OFF

Melody control

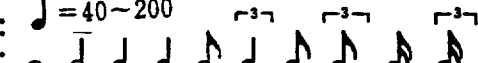
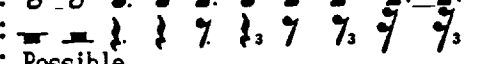
Tempo range : ♩ = 40 ~ 200
 Note length : 
 Rest length : 
 Tie/Slur : Possible
 No. of melodies : Maximum 8 melodies
 No. of total steps : Maximum 991 steps (including notes, rests, JUMP and END commands).
 Repeat function : It is possible to program any melody to be repeated.

External control

Control signal : To control external equipment, timing output is possible in accordance with the internal ROM Data. The pulse width can be selected as either 8.5ms or the same length as the note interval.

DAC : 9 bit (Sampling frequency is 58kHz. LPF are required for each application.)

■Electrical characteristics

1. Absolute maximum ratings

Parameter	Rated	Unit
Input voltage	-0.3~7.0	V
Operating temperature	-20~85°C	°C
Storage temperature	-50~125	°C

2. Recommended operating conditions

Parameter	Symbol	Minimum	Typical	Maximum	Unit
Power supply voltage	V _{DD}	2.4	3.0	5.25	V
	G _{ND}	0	0	0	V

3. DC characteristics

Parameter	Symbol	Condition	Minimum	Typical	Maximum	Unit
Low-level input voltage	V _{IL}		-0.3		0.25V _{DD}	V
High-level input voltage	V _{IH}		0.75V _{DD}		V _{DD} +5	V
Low-level clock input voltage	V _{CL}		-0.3		0.4	V
High-level clock input voltage	V _{CH}		2.0		V _{DD} +0.5	V
Input current	I _I	V _{IN} =0V	30		100	μA
Input leakage current	I _{LI}	V _{IN} =0~5V			+10	μA
Low-level output voltage	V _{OL}	I _{OL} =1mA	0		0.5	V
High-level output voltage	V _{OH}	I _{OH} =200μA	0.8V _{DD}		V _{DD} +0.5	V
Stand-by current	I _{ST}				0.9	μA
Power supply current	I _{DD}				10	μA

4. Input/Output capacitance characteristic

Parameter	Symbol	Condition	Minimum	Typical	Maximum	Unit
Input pin capacitance	C _I	f=1MHz V=3.0			10	PF
Output pin capacitance	C _O	f=1MHz V=3.0			10	PF

5. Clock characteristics

Parameter	Rating	Unit
Standard frequency	447,443	kHz
Oscillator frequency range	~	kHz

6. AC characteristics

Parameter	Symbol	Rating	Unit
[Clock]			
Clock frequency	f_{CLK}	447.44 (Typ)	KHz
Clock duty	f_D	40~60	%
[Common to both modes]			
/IC pulse width	T_{IC}	5 (Min)	msec
MOD, /ST time interval	$T_{S(MO-ST)}$	0 (Min)	CLOCK
/IC, /ST time interval	T_{IC-ST}	32 (Fin)	CLOCK
/ST and /PLAY start delay	$T_{S(ST-PY)}$	1 (Max)	CLOCK
/ST, AD start delay	$T_{S(ST-MUSIC)}$	32768 (Fix)	CLOCK
S0, S1, S2 setup time	T_{ST}	1 (Min)	CLOCK
S0, S1, S2 hold time	T_{HO}	1 (Min)	CLOCK
DAC off time	D_{OT}	983040 (Fix)	CLOCK
Analogue output voltage	V_{OA}	$0.63V_{DD}$ (Min) $1V_{DD}$ (Max)	V _{P-P}
[Level hold mode]			
/ST and /PLAY end delay	$T_{E(ST-PY)}$	16 (Min) 32 (Max)	CLOCK
[One shot mode]			
/ST pulse width	$T_{S(ST-ST)}$	32 (Min)	CLOCK
MOD pulse width	T_{MD}	1 (Min)	CLOCK
MOD and MOD time interval	T_{MD-MD}	2 (Max)	CLOCK

■ Timing chart

1. Level Hold mode

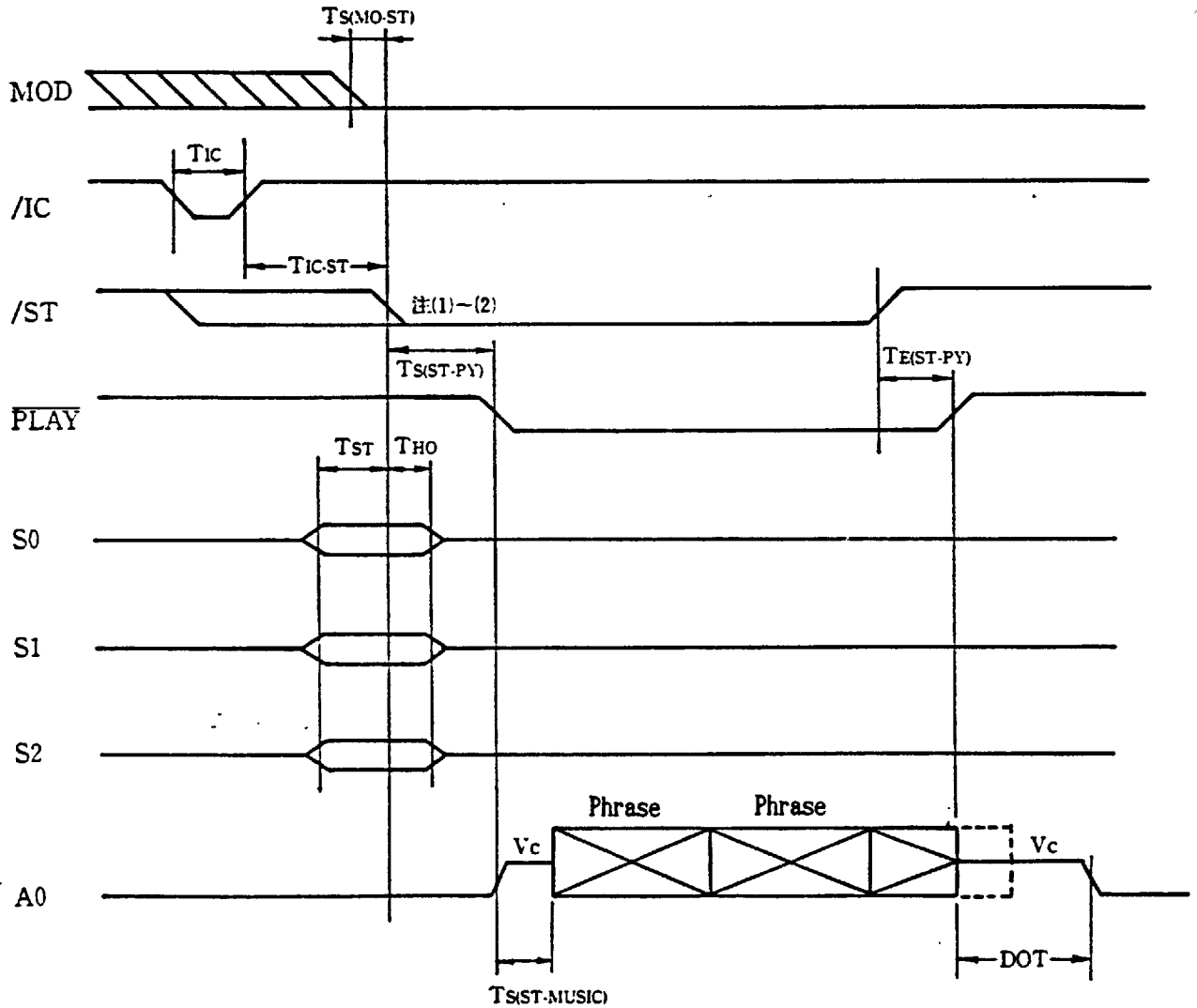

- Note(1) There are two circuits for the internal initial clear operation; one starts operation when /IC falls, and the other starts operation when /IC rises. TIC-ST requires a period of 32 clocks. The start time should be after 32 clocks even if both /ST and /IC falls at the same time.
- (2) When the timing operation of /ST falling is delayed more than 33 clocks after /IC rises, the information from the S0, S1, S2 and MCD pins is taken when /ST falls.
- (3) Initial clear requires an "L" state of more than 5 μ s, after VDD reaches 3.0V.

2. One Shot mode

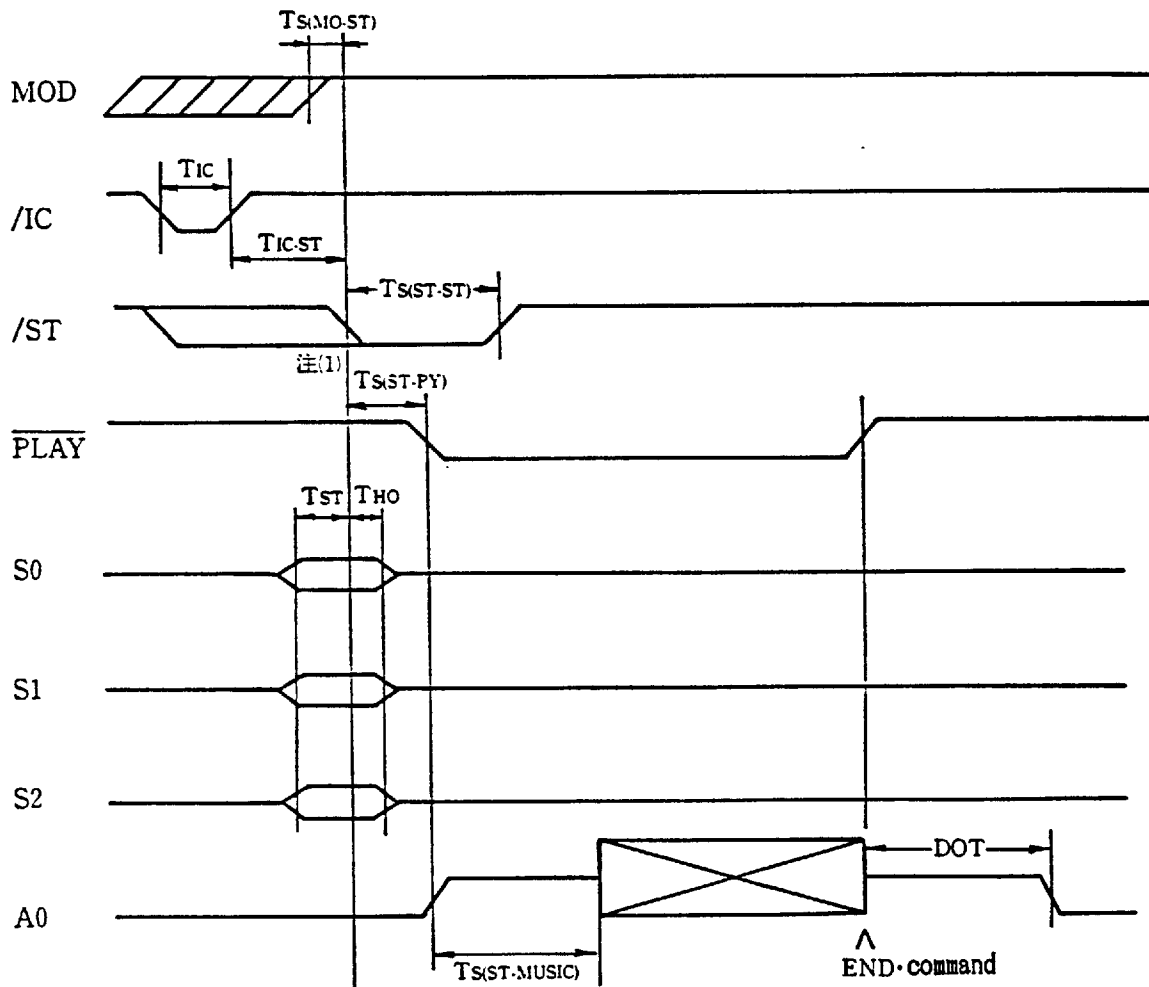

Note (1) Notes (1) to (3) for the Level Hold mode are applicable to the timing operations of /IC and /ST.

- (2) To enter into stand-by mode immediately after the end of the performance, /ST should be returned to "H" before the end of the performance (before the END command is activated).
- (3) After /ST changes from "L" to "H", /ST becomes inhibited to prevent malfunction by chattering, until the END command is enabled.

3. User programmable repeat function (Effective only during One Shot mode)

- A sequence can be repeated a maximum of 16 times by reading repetition cycles data during performance, as below.

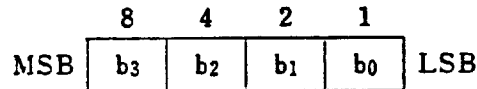

[When b₃ = b₂ = b₁ = b₀ = "H", the sequence will be repeated 16 times. The sequence will be repeated according to the "H" bits. (Example) When b₃ = b₂ = "L", b₁ = b₀ = "H", the sequence will be repeated 3 times.]

If the number of repeat sequences is not set before the initial END command, the number stored in the ROM will be utilized. (Any attempts to set the number of repeat sequences after the initial END command will be ignored.)

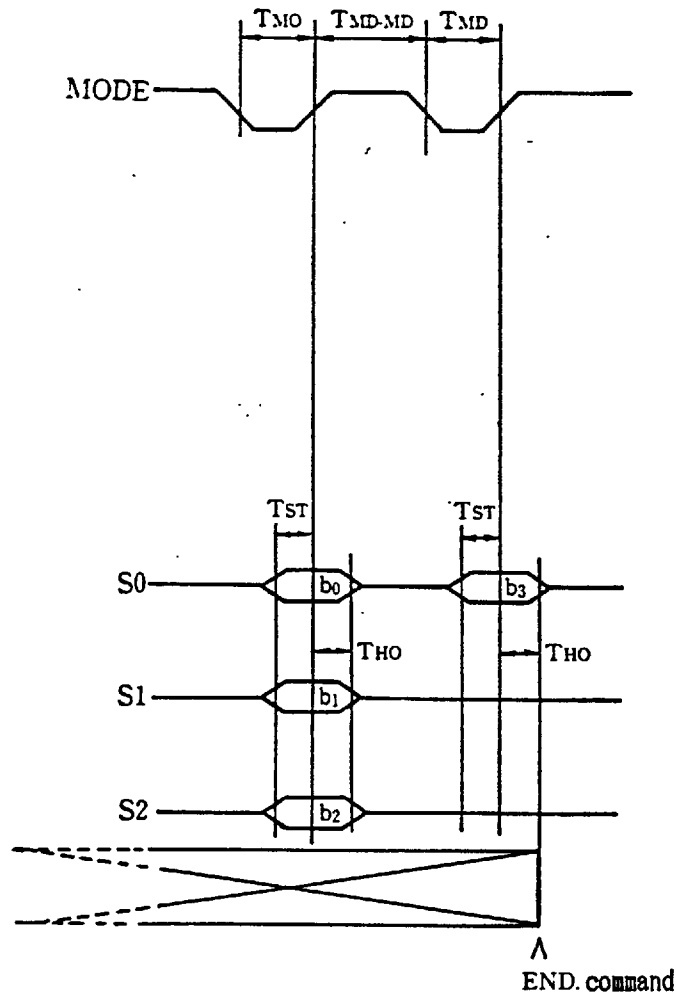

Sample of circuit diagram

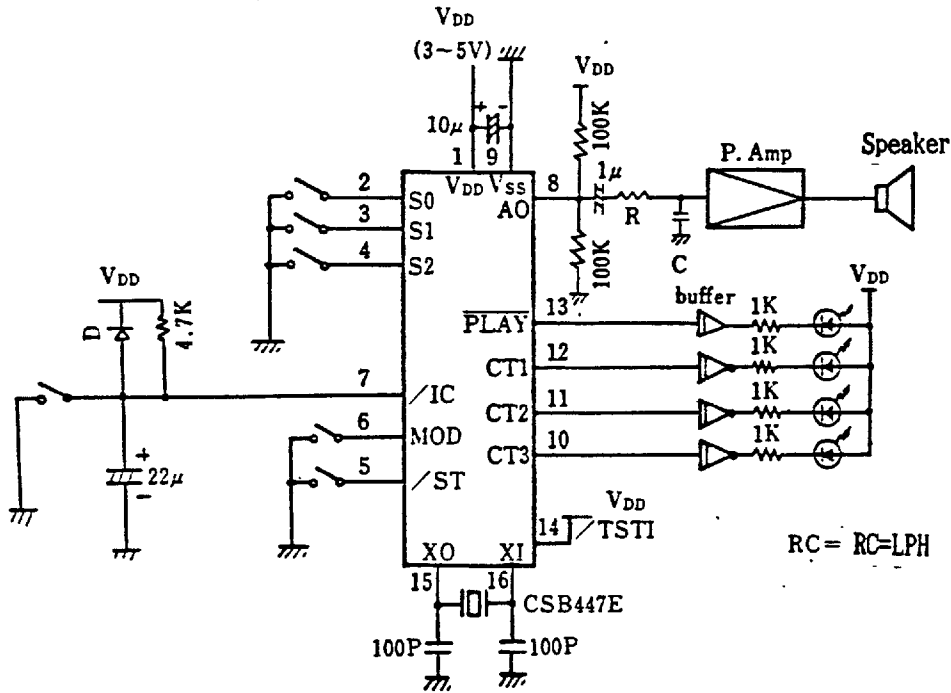

External Dimensions

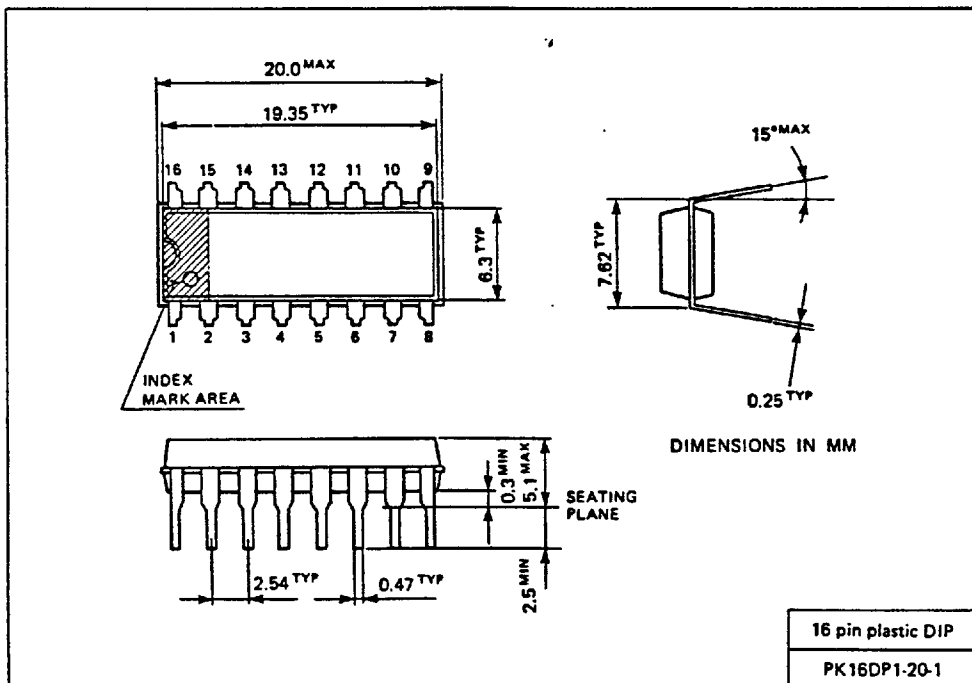

YAMAHA

YMU251XX

AGENCY

YAMAHA CORP.

Address inquiries to:

Semi-conductor Sales Department

- Head Office 203, Matsunokijima, Toyooka-mura,
Iwata-gun, Shizuoka-ken, 438-01
Electronic Equipment business section
Tel. 0539-62-4918 Fax. 0539-62-5054
- Tokyo Office 3-4, Surugadai Kanda, Chiyoda-ku,
Tokyo, 101
Ryumeikan Bldg. 4F
Tel. 03-3255-4481 Fax. 03-3255-4488
- Osaka Office 3-12-9, Minami Senba, Chuo-ku,
Osaka City, Osaka, 542
Shinsaibashi Plaza Bldg. 4F
Tel. 06-252-7980 Fax. 06-252-5615
- U.S.A. Office YAMAHA Systems Technology.
981 Ridder Park Drive San Jose, CA95131
Tel. 408-437-3133 Fax. 408-437-8791

46798

9945524 0002211 07T