

DIESEL ENGINE-GENERATOR SET

500-XC6DT2

500 ekW / 60 Hz / Standby
208 - 4160V



SYSTEM RATINGS

Standby

OE Type	208V**	240V**	480V**	600V**	4160V
Phase	3	3	3	3	3
PF	0.8	0.8	0.8	0.8	0.8
Hz	60	60	60	60	60
kW	500	500	500	500	500
kVA	625	625	625	625	625
AMPS	1735	1504	752	601	87
skVA@30%					
Voltage Dip	1470	1470	1280	1040	1240
Generator Model*	572RSL4029	572RSL4029	572RSL4027	572RSS4270	573FSM4354
Temp Rise	130°C/27°C	130°C/27°C	130°C/27°C	125°C/40°C	130°C/27°C
Connection	12 LEAD LOW WYE	12 LEAD HI DELTA	12 LEAD HI WYE	4 LEAD WYE	6 LEAD WYE

Note: Prime Power is not available for this model.

* The Generator Model Number identified in the table is for standard C Series Configuration. Consult the factory for alternate configuration.

** UL2200 Offered

FACTS

- // EPA Tier 2 Certified
- // Engine-Generator Set Tested to ISO 8528-5 for Transient Response
- // UL2200, CSA Listing Offered
- // Accepts Rated Load in One Step Per NFPA 110, Level 1
- // All engine-generator sets are prototype and factory tested
- // MTU Onsite Energy is a single source supplier
- // Global Product Support
- // 2 Year Standard Warranty
- // Series 60 (6063HK36) Diesel Engine
 - 14.0 Liter Displacement
 - Electronic Unit Pump Injection
 - 4-Cycle
- // Complete Range of Accessories
- // Permanent Magnet Generator (PMG)
 - Brushless, Rotating Field
 - 300% Short Circuit Capability
 - 2/3 Pitch Windings
- // Digital Control Panel(s)
 - UL Recognized, e_{us}, NFPA 110
 - Complete System Metering
 - LCD Display
- // Cooling System
 - Integral Set-Mounted
 - Engine Driven Fan

STANDARD EQUIPMENT

// Engine

Air Cleaners
 Oil Pump
 Full Flow Oil Filter
 Jacket Water Pump
 Thermostat
 Exhaust Manifold - Dry
 Blower Fan & Fan Drive
 Radiator - Unit Mounted
 Electric Starting Motor - 24V
 Governor - Electric Isochronous
 Base - Structural Steel
 SAE Flywheel & Bell Housing
 Charging Alternator - 24V
 Battery Box & Cables
 Flexible Fuel Connectors
 Flexible Exhaust Connection
 EPA Certified Engine

// Generator

NEMA MG1, IEEE and ANSI standards compliance for temperature rise and motor starting
 Sustained short circuit current of up to 300% of the rated current for up to 10 seconds
 Self-Ventilated and Drip-Proof
 Superior Voltage Waveform
 Digital, Solid State, Volts-per-Hertz Regulator
 No Load to Full Load Regulation
 Brushless Alternator with Brushless Pilot Exciter
 4 Pole, Rotating Field
 130°C Standby Temperature Rise
 1 Bearing, Sealed
 Flexible Coupling
 Full Amortisseur Windings
 125% Rotor Balancing
 3-Phase Voltage Sensing
 ± .25% Voltage Regulation
 100% of Rated Load - One Step
 3% Maximum Harmonic Content

// Digital Control Panel(s)

Digital Metering
 Engine Parameters
 Generator Protection Functions
 Engine Protection
 SAE J1939 Engine ECU Communications
 Windows-Based Software
 Multilingual Capability
 Remote Communications to our RDP-110 Remote Annunciator
 16 Programmable Contact Inputs
 7 Contact Outputs
 UL Recognized, us, CE Approved
 Event Recording
 IP 54 Front Panel Rating with Integrated Gasket
 NFPA110 Level Compatible

APPLICATION DATA

// Engine

Manufacturer	MTU Detroit Diesel
Model	Series 60 (6063HK36)
Type	4-Cycle
Arrangement	6-Inline
Displacement: Cu In (lit)	855 (14)
Bore: in (cm)	5.24 (13.3)
Stroke: in (cm)	6.61 (16.8)
Compression Ratio	15:1
Rated RPM	1,800
Engine Governor	DDEC
Max Power: Standby: bhp (kWm)	760 (567)
Regulation	±25%
Frequency	60 Hz
Air Cleaner	Dry

// Liquid Capacity (Lubrication)

Total Oil System: gal (lit)	9.5 (36)
Engine Jacket Water Capacity: gal (lit)	6 (23)
System Coolant Capacity: gal (lit)	27 (102)

// Electrical

Electric Volts DC	24
Cold Cranking Amps Under 0°F (-17.8°C)	950

// Fuel System

Fuel Supply Connection Size	3/4" NPT
Fuel Return Connection Size	1/2" NPT
Maximum Fuel Lift: ft (m)	7 (2.1)
Recommended Fuel	Diesel #2
Total Fuel Flow: gal/hr (lit/hr)	105.3 (399)

// Fuel Consumption

At 100% of Power Rating: gal/hr (lit/hr)	35.6 (134.8)
At 75% of Power Rating: gal/hr (lit/hr)	26.8 (101.4)
At 50% of Power Rating: gal/hr (lit/hr)	18.7 (70.8)

// Cooling - Radiator System (Standby)

Ambient Capacity of Radiator: °F (°C)	122 (50)
Max. Restriction of Cooling Air, Intake, and Discharge Side of Rad.: in. H ₂ O (kPa)	0.5 (0.12)
Water Pump Capacity: gpm (lit/min)	111 (420)
Heat Rejection to Coolant: BTUM (kW)	9,650 (170)
Heat Rejection to Air to Air: BTUM (kW)	8,200 (144)
Heat Radiated to Ambient: BTUM (kW)	6,421 (113)

// Air Requirements

Aspirating: *SCFM (m ³ /min)	1,514 (43)
Air Flow Required for Rad.	
Cooled Unit: *SCFM (m ³ /min)	25,873 (733)
Air Flow Required for Heat Exchanger/Remote Rad. based on 25°F Rise: *SCFM (m ³ /min)	14,482 (413)

* Air density = 0.0739 lbm/ft³ (1.184 kg/m³)

// Exhaust System

Gas Temp. (Stack): °F (°C)	1,030 (554)
Gas Volume at Stack	
Temp: CFM (m ³ /min)	4,227 (120)
Maximum Allowable	
Back Pressure: in. H ₂ O (kPa)	40.8 (10.2)

WEIGHTS AND DIMENSIONS

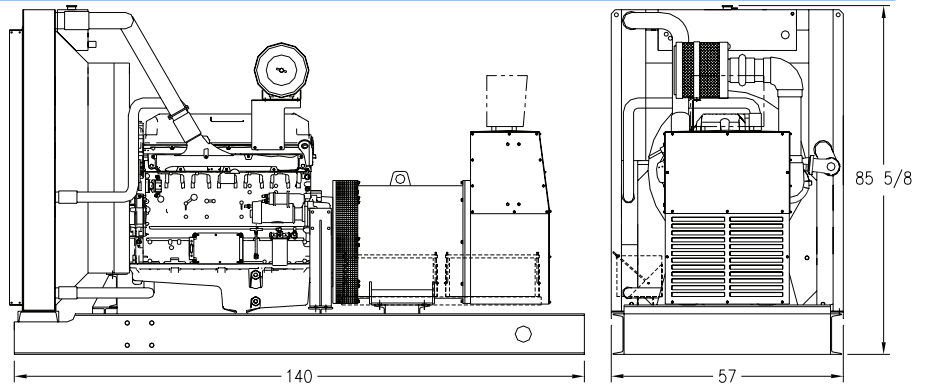

Drawing above for illustration purposes only, based on standard open power 480 volt generator. Lengths may vary with other voltages. Do not use for installation design.

System	Dimensions (L x W x H)	Weight (less tank)
OPU	140 x 57 x 85.6 in (3,560 x 1,450 x 2,180 mm)	7,311 lb (3,316 kg)

Weights and dimensions are based on open power units and are estimates only. Consult the factory for accurate weights and dimensions for your specific generator set.

SOUND DATA

Unit Type	Standby Full Load (dBA)	Standby No Load (dBA)
OPU w/Critical Grade Muffler (dBA)	98	90
Sound Attenuated Enclosure (dBA)	96.5	90

Measurements for sound data are taken at 23 ft (7 m).

EMISSIONS DATA

NO _x + NMHC	CO	PM
4.65	0.51	0.06

All units are in g/hp-hr and are EPA D2 cycle values.

Emission levels of the engine may vary as a function of ambient temperature, barometric pressure, humidity, fuel type and quality, installation parameters, measuring instrumentation, etc. The data provided are laboratory results from one engine representing this rating. The data was obtained under controlled environmental conditions with calibrated instrumentation traceable to the United States National Bureau of Standards and in compliance with US EPA regulations found within 40 CFR Part 89. The weighted cycle value from each engine is guaranteed to be below the US EPA Standards at the US EPA defined conditions.

RATING DEFINITIONS AND CONDITIONS

- // Ambient capability factor at 984 ft (300 m). Consult your local MTU Onsite Energy Power Generation Distributor for other altitudes.
- // Standby ratings apply to installations served by a reliable utility source. The standby rating is applicable to varying loads for the duration of a power outage. No overload capability for this rating. Ratings are in accordance with ISO-3046/1, BS 5514, AS 2789, and DIN 6271.
- // Deration Factor:
 - Altitude:** 1% per 1,000 ft (305 m) above 600 ft (183 m) with a maximum of 6,000 ft (1,830 m) altitude.
 - Temperature:** 1% per 10°F (5.5°C) above 77°F (25°C).

Materials and specifications subject to change without notice.