

Differential Positive ECL (DPECL) SU-A29F0 Series

Description

The **SU-A29F0 Series** of quartz crystal oscillators provide DPECL compatible signals. Systems designers may now specify space-saving, cost-effective packaged PECL oscillators to meet their timing requirements.

Features

- Wide frequency range – 280.0+MHz to 350.0MHz
- User specified tolerance available
- Will withstand SMD reflow temperatures of 253°C for 4 minutes maximum
- Space-saving alternative to discrete component oscillators
- High shock resistance, to 1000g
- 3.3 volt operation
- High Reliability - NEL HALT/HASS qualified for crystal oscillator start-up conditions
- Wavecrest jitter characterization available
- Overtone technology
- High Q Crystal actively tuned oscillator circuit
- No internal PLL avoids cascading PLL problems
- Power supply decoupling internal
- Metal lid electrically connected to ground to reduce EMI
- Gold plated pads

Electrical Connection

Pin Connection

- 1 Enable
- 2 N/C
- 3 Ground
- 4 Q Output
- 5 /Q Output
- 6 V_{CC}

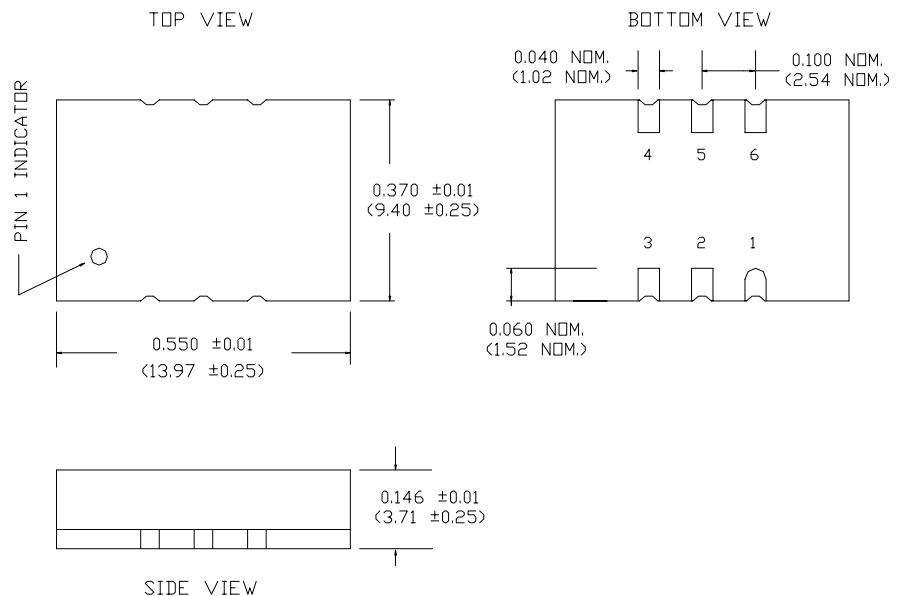

DIMENSIONS IN: INCHES (mm)

SU-A29F0 Series Continued
Differential Positive ECL (DPECL)

Rev. B

Operating Conditions and Output Characteristics

Electrical Characteristics

Parameter	Symbol	Conditions	Min	Typical	Max
Frequency	----	----	280.0+MHz	----	350.0MHz
Duty Cycle	----	@ V_{CC} -1.29V	45/55%	----	55/45%
Logic 0 ⁽²⁾⁽⁷⁾	V_{OL}	----	----	----	V_{CC} -1.62V
Logic 1 ⁽²⁾⁽⁷⁾	V_{OH}	----	V_{CC} -1.025V	----	----
Rise & Fall Time	tr,tf	20-80% V_O with 50 ohm load to V_{CC} -2V	----	----	500ps
T_{pd} ⁽⁶⁾	----	----	-200psec	----	+200psec
Jitter, RMS ⁽³⁾	----	----	----	----	1 ps
Enable Voltage ⁽⁵⁾	----	with $V_{EE} = 0V$	2.0V	----	----
Disable Voltage	----	with $V_{EE} = 0V$	----	----	0.8V
Frequency Stability ⁽¹⁾	dF/F	Overall conditions including: voltage, calibration, temp., 10 yr aging, shock, vibration	-100ppm	----	+100ppm

General Characteristics

Parameter	Symbol	Conditions	Min	Typical	Max
Supply Voltage ⁽⁴⁾	V_{CC}	3.3V±5%	3.135V	3.3V	3.465V
Supply Current	I_{CC}	50 ohm termination To 2.00V below V_{CC}	0.0 mA	----	105 mA
Output current	I_O	Low level Output Current	0.0 mA	----	±50.0 mA
Operating temperature	T_A	----	0°C	----	70°C
Storage temperature	T_S	----	-55°C	----	125°C
Power Dissipation	P_D	----	----	----	364 mW
Lead temperature	T_L	Soldering, 10 sec.	----	----	300°C
Load ⁽⁷⁾	50 Ohm to V_{CC} -2V or Thevenin Equivalent, Bias Required	----	----	----	----
Start-up time	t_s	----	----	2 ms	10 ms

Environmental and Mechanical Characteristics

Mechanical Shock	Per MIL-STD-202, Method 213, Condition E
Thermal Shock	Per MIL-STD-833, Method 1011, Condition A
Vibration	0.060" double amplitude 10 Hz to 55 Hz, 35g's 55Hz to 2000 Hz
Soldering Condition	300°C for 10 seconds
Hermetic Seal	Leak rate less than 1×10^{-8} atm.cc/sec of helium

Footnotes:

- Standard frequency stability (±20,±25,±50ppm & others available)
- V_{OL} , V_{OH} , referenced to ground (V_{EE}) with $V_{CC} = 3.3V$
- Jitter performance is frequency dependent. Please contact factory for full Wavecrest characterization. RMS jitter bandwidth of 12kHz to 20MHz.
- Internal high frequency power source decoupling.
- Open to enable pin also enables the output.
- T_{pd} is phase shift between the falling edge of pin 4 at 2.0V and the rising edge of pin 5 at 2.01V.
- Logic levels are dependant on specified load of 50 ohms to V_{CC} -2 volts.

Creating a Part Number	
SU - A29FX - FREQ	
Package Code	Tolerance/Performance
SU 6 pad 9x14mm SMD	0 ±100ppm 0-70°C
	1 ±50ppm 0-70°C
	7 ±25ppm 0-70°C
Input Voltage	9 Customer Specific
Code Specification	A ±20ppm 0-70°C
A 3.3V	B ±50ppm -40 to +85°C
B 2.5V	C ±100ppm -40 to +85°C

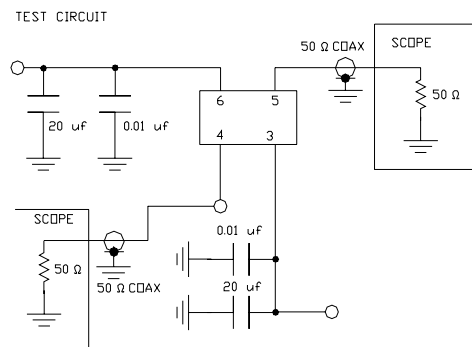

TEST CIRCUIT USES A SPLIT SUPPLY OF +2V AND -1.3V FOR EASE OF TESTING.