



## UC8383

CMOS IC

### STEP-UP DC/DC CONVERTER

#### DESCRIPTION

The UTC **UC8383** is a high efficiency VFM controlled step-up DC/DC converter. The UTC **UC8383** is designed to have low start up voltage and low quiescent current: The UTC **UC8383** can realize the conversion from the input voltage to the selected output voltage (2.5V ~ 5.0V) only using an inductor, a diode and an output capacitor.

Its typical applications include: cellular telephones, pagers, video camera, PDA and hand held instruments, palmtop, notebook computer, portable equipment and battery powered equipment.

#### FEATURES

- \* 0.8V Start-Up Voltage
- \* Low Supply Current of Typical be18 $\mu$ A
- \* Wide Output Voltage Range of 2.5V~5.0V
- \* Output Voltage Accuracy  $\pm$ 2%
- \* Output Current Up to 100mA
- \* Low Ripple and Low Noise
- \* High Efficiency Up to 85%
- \* Low Profile and Minimum External Components

#### ORDERING INFORMATION

Ordering Number		Package	Pin Assignment			Packing
Lead Free	Halogen Free		1	2	3	
UC8383L-xx-AB3-R	UC8383G-xx-AB3-R	SOT-89	V <sub>SS</sub>	V <sub>OUT</sub>	L <sub>X</sub>	Tape Reel

<p>UC8383L-xx-AB3-R</p>	<p>(1)Packing Type</p> <p>(2)Package Type</p> <p>(3)Voltage Code</p> <p>(4)Lead Free</p>	<p>(1) R: Tape Reel</p> <p>(2) AB3: SOT-89</p> <p>(3) xx: refer to Marking Information</p> <p>(4) G: Halogen Free, L: Lead Free</p>
-------------------------	--	---

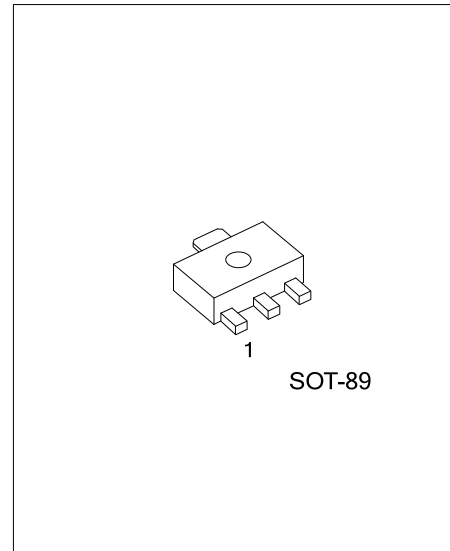

■ MARKING INFORMATION

PACKAGE	VOLTAGE CODE	MARKING
SOT-89	25:2.5V 27:2.7V 28:2.8V 30:3.0V 33:3.3V 36:3.6V 50:5.0V	

■ PIN DESCRIPTION

PIN NO	PIN NAME	DESCRIPTION
1	V <sub>SS</sub>	GND.
2	V <sub>OUT</sub>	Output voltage monitor, IC internal supply voltage
3	L <sub>x</sub>	Switch pin

■ BLOCK DIAGRAM

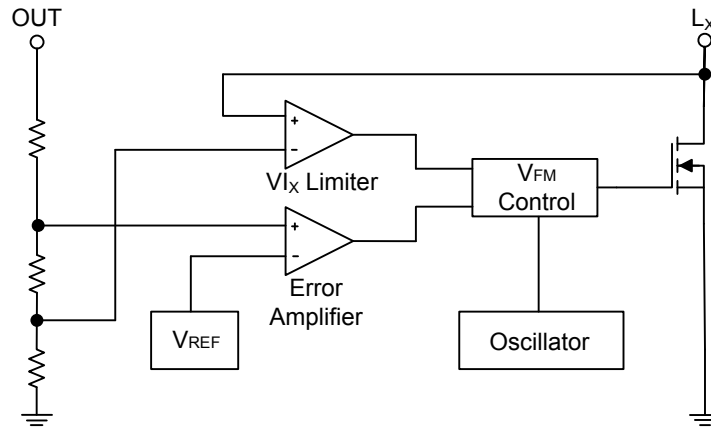

### ■ ABSOLUTE MAXIMUM RATING

PARAMETER	SYMBOL	RATINGS	UNIT
Output Voltage	$V_{OUT}$	5.5	V
Input Voltage	$V_{IN}$	5.5	V
LX Pin Voltage	$V_{LX}$	5.5	V
LX Pin Output Current	$I_{LX}$	Internally limited	
Power Dissipation ( $T_a=25^\circ\text{C}$ )	$P_D$	170	mW
Derating Rate over $T_a=25^\circ\text{C}$		1.7	$^\circ\text{C}/\text{mW}$
Operating Junction Temperature	$T_J$	-25 ~ +85	$^\circ\text{C}$
Storage Temperature	$T_{STG}$	-55 ~ +125	$^\circ\text{C}$

Note: Absolute maximum ratings are those values beyond which the device could be permanently damaged.

Absolute maximum ratings are stress ratings only and functional device operation is not implied.

### ■ THERMAL DATA

PARAMETER	SYMBOL	RATINGS	UNIT
Junction to Case	$\theta_{JC}$	17	$^\circ\text{C}/\text{W}$

### ■ ELECTRICAL CHARACTERISTICS ( $I_{OUT} = 10\text{mA}$ , $T_a = 25^\circ\text{C}$ , unless otherwise specified.)

#### UC8383-2.5V ( $V_{IN} = 1.5\text{V}$ )

PARAMETER	SYMBOL	TEST CONDITIONS	MIN	TYP	MAX	UNIT
Output Voltage	$V_{OUT}$		2.45	2.5	2.55	V
Start-up Voltage ( $V_{IN}-V_F$ ) (Note 1)	$V_{START}$	$I_{OUT} = 1\text{mA}$		0.8	1.2	V
Hold-on Voltage	$V_{HOLD}$	$I_{OUT} = 1\text{mA}$	0.6			V
Supply Current	$I_{SUPPLY}$	$I_{OUT} = 0$		18		$\mu\text{A}$
Internal Switch $R_{DS(ON)}$	$R_{LX}$	$I_{LX} = 150\text{mA}$		850		$\text{m}\Omega$
Internal Leakage Current	$I_{LX(LEAK)}$	$V_{LX} = 4\text{V}$ , $V_{OUT} = 3\text{V}$			0.5	$\mu\text{A}$
Maximum Oscillator Frequency	$f_{OSC}$			120		KHz
Oscillator Duty Cycle	$D_{ty}$			80		%
Efficiency	$\eta$	$I_{OUT} = 50\text{mA}$		82		%

#### UC8383-2.7V ( $V_{IN} = 1.6\text{V}$ )

PARAMETER	SYMBOL	TEST CONDITIONS	MIN	TYP	MAX	UNIT
Output Voltage	$V_{OUT}$		2.646	2.7	2.754	V
Start-up Voltage ( $V_{IN}-V_F$ ) (Note)	$V_{START}$	$I_{OUT} = 1\text{mA}$		0.8	1.2	V
Hold-on Voltage	$V_{HOLD}$	$I_{OUT} = 1\text{mA}$	0.6			V
Supply Current	$I_{SUPPLY}$	$I_{OUT} = 0$		18		$\mu\text{A}$
Internal Switch $R_{DS(ON)}$	$R_{LX}$	$I_{LX} = 150\text{mA}$		850		$\text{m}\Omega$
Internal Leakage Current	$I_{LX(LEAK)}$	$V_{LX} = 4\text{V}$ , $V_{OUT} = 3.3\text{V}$			0.5	$\mu\text{A}$
Maximum Oscillator Frequency	$f_{OSC}$			120		KHz
Oscillator Duty Cycle	$D_{ty}$			80		%
Efficiency	$\eta$	$I_{OUT} = 50\text{mA}$		82		%

#### UC8383-2.8V ( $V_{IN} = 1.7\text{V}$ )

PARAMETER	SYMBOL	TEST CONDITIONS	MIN	TYP	MAX	UNIT
Output Voltage	$V_{OUT}$		2.744	2.8	2.856	V
Start-up Voltage ( $V_{IN}-V_F$ ) (Note)	$V_{START}$	$I_{OUT} = 1\text{mA}$		0.8	1.2	V
Hold-on Voltage	$V_{HOLD}$	$I_{OUT} = 1\text{mA}$	0.6			V
Supply Current	$I_{SUPPLY}$	$I_{OUT} = 0$		18		$\mu\text{A}$
Internal Switch $R_{DS(ON)}$	$R_{LX}$	$I_{LX} = 150\text{mA}$		850		$\text{m}\Omega$
Internal Leakage Current	$I_{LX(LEAK)}$	$V_{LX} = 4\text{V}$ , $V_{OUT} = 3.3\text{V}$			0.5	$\mu\text{A}$
Maximum Oscillator Frequency	$f_{OSC}$			120		KHz
Oscillator Duty Cycle	$D_{ty}$			80		%
Efficiency	$\eta$	$I_{OUT} = 50\text{mA}$		82		%

■ ELECTRICAL CHARACTERISTICS(Cont.)

**UC8383-3.0V** ( $V_{IN} = 1.8V$ )

PARAMETER	SYMBOL	TEST CONDITIONS	MIN	TYP	MAX	UNIT
Output Voltage	$V_{OUT}$		2.94	3	3.06	V
Start-up Voltage ( $V_{IN}-V_F$ ) (Note)	$V_{START}$	$I_{OUT} = 1mA$		0.8	1.2	V
Hold-on Voltage	$V_{HOLD}$	$I_{OUT} = 1mA$	0.6			V
Supply Current	$I_{SUPPLY}$	$I_{OUT} = 0$		18		$\mu A$
Internal Switch $R_{DS(ON)}$	$R_{LX}$	$I_{LX} = 150mA$		850		$m\Omega$
Internal Leakage Current	$I_{LX(LEAK)}$	$V_{LX} = 4V, V_{OUT} = 3.5V$		0.1	0.5	$\mu A$
Maximum Oscillator Frequency	$f_{OSC}$			120		KHz
Oscillator Duty Cycle	$D_{ty}$			80		%
Efficiency	$\eta$	$I_{OUT} = 50mA$		82		%

**UC83830-3.3V** ( $V_{IN} = 2V$ )

PARAMETER	SYMBOL	TEST CONDITIONS	MIN	TYP	MAX	UNIT
Output Voltage	$V_{OUT}$		3.234	3.3	3.366	V
Start-up Voltage ( $V_{IN}-V_F$ ) (Note)	$V_{START}$	$I_{OUT} = 1mA$		0.8	1.2	V
Hold-on Voltage	$V_{HOLD}$	$I_{OUT} = 1mA$	0.6			V
Supply Current	$I_{SUPPLY}$	$I_{OUT} = 0$		18		$\mu A$
Internal Switch $R_{DS(ON)}$	$R_{LX}$	$I_{LX} = 150mA$		850		$m\Omega$
Internal Leakage Current	$I_{LX(LEAK)}$	$V_{LX} = 4V, V_{OUT} = 3.8V$			0.5	$\mu A$
Maximum Oscillator Frequency	$f_{OSC}$			120		KHz
Oscillator Duty Cycle	$D_{ty}$			80		%
Efficiency	$\eta$	$I_{OUT} = 50mA$		84		%

**UC83830-3.6V** ( $V_{IN} = 2V$ )

PARAMETER	SYMBOL	TEST CONDITIONS	MIN	TYP	MAX	UNIT
Output Voltage	$V_{OUT}$		3.528	3.6	3.672	V
Start-up Voltage ( $V_{IN}-V_F$ ) (Note)	$V_{START}$	$I_{OUT} = 1mA$		0.8	1.2	V
Hold-on Voltage	$V_{HOLD}$	$I_{OUT} = 1mA$	0.6			V
Supply Current	$I_{SUPPLY}$	$I_{OUT} = 0$		18		$\mu A$
Internal Switch $R_{DS(ON)}$	$R_{LX}$	$I_{LX} = 150mA$		850		$m\Omega$
Internal Leakage Current	$I_{LX(LEAK)}$	$V_{LX} = 4V, V_{OUT} = 3.8V$			0.5	$\mu A$
Maximum Oscillator Frequency	$f_{OSC}$			120		KHz
Oscillator Duty Cycle	$D_{ty}$			80		%
Efficiency	$\eta$	$I_{OUT} = 50mA$		84		%

**UC83830-5.0V** ( $V_{IN} = 3V$ )

PARAMETER	SYMBOL	TEST CONDITIONS	MIN	TYP	MAX	UNIT
Output Voltage	$V_{OUT}$		4.9	5.0	5.1	V
Start-up Voltage ( $V_{IN}-V_F$ ) (Note)	$V_{START}$	$I_{OUT} = 1mA$		0.8	1.2	V
Hold-on Voltage	$V_{HOLD}$	$I_{OUT} = 1mA$	0.6			V
Supply Current	$I_{SUPPLY}$	$I_{OUT} = 0$		18		$\mu A$
Internal Switch $R_{DS(ON)}$	$R_{LX}$	$I_{LX} = 150mA$		700		$m\Omega$
Internal Leakage Current	$I_{LX(LEAK)}$	$V_{LX} = 4V, V_{OUT} = 5.5V$		0.1	0.5	$\mu A$
Maximum Oscillator Frequency	$f_{OSC}$			120		KHz
Oscillator Duty Cycle	$D_{ty}$			80		%
Efficiency	$\eta$	$I_{OUT} = 50mA$		85		%

Note: The minimum value of the device start-up voltage is strictly a function of the forward voltage ( $V_F$ ) of the diode.

## ■ TYPICAL APPLICATION

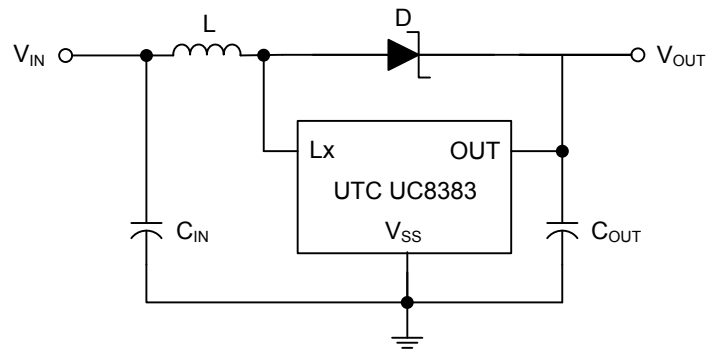

Application Circuit

## Application Circuit Notes:

1. The inductors: an inductor value of  $47\mu\text{H}$  performs well in this application.
2. The diode: an high switching speed and low forward voltage diode.
3. The input capacitor: A value of  $4.7\mu\text{F}$  tantalum capacitor is enough to guarantee stability.
4. The output capacitor: The best choice for the value of the output capacitance is  $47\mu\text{F}$  tantalum capacitor. And the capacitance value should be in the range of about  $10\mu\text{F}$ - $100\mu\text{F}$ .

■ TYPICAL CHARACTERISTICS

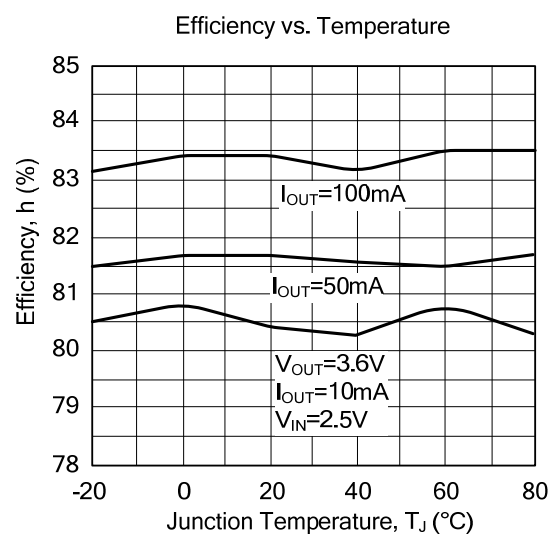
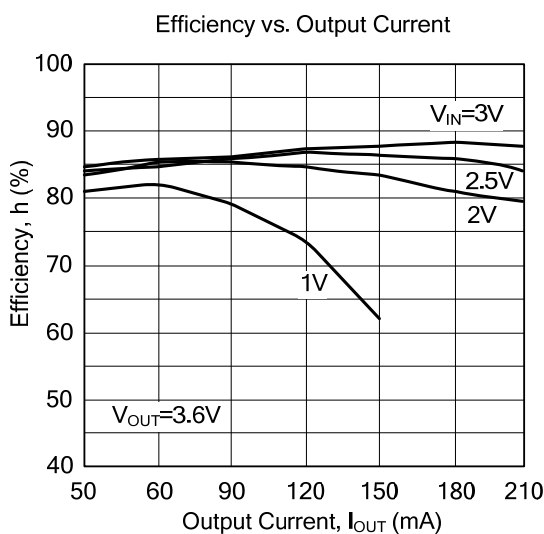
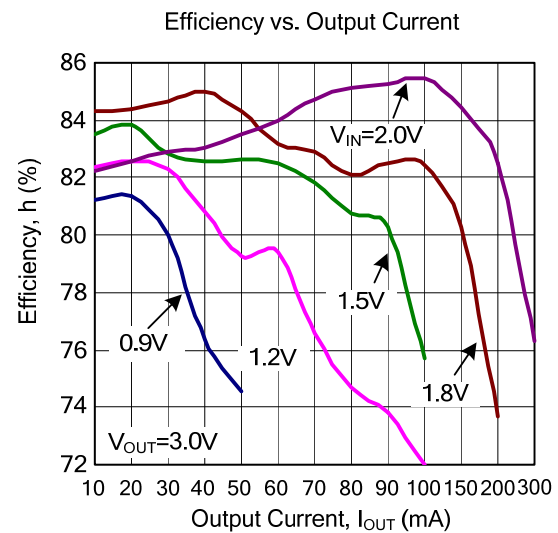
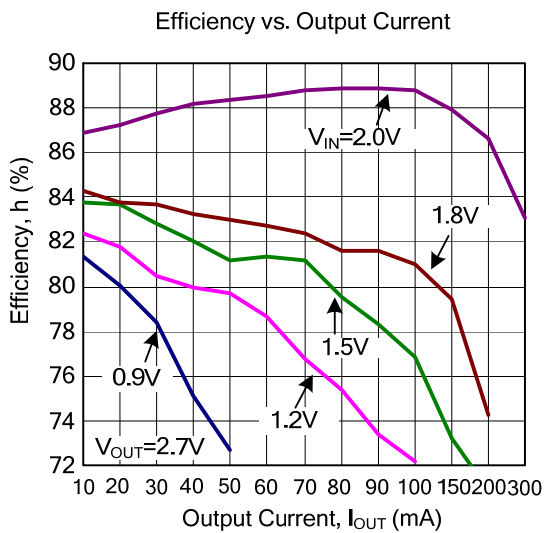
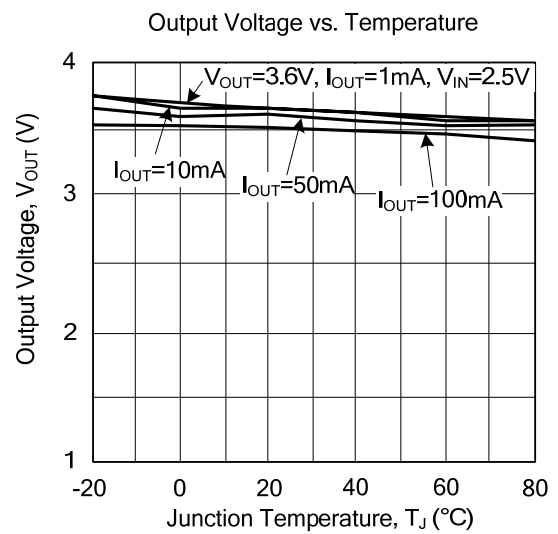
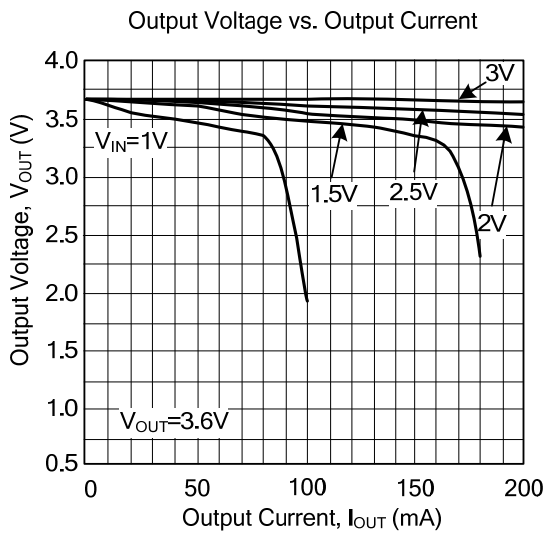

■ TYPICAL CHARACTERISTICS(Cont.)

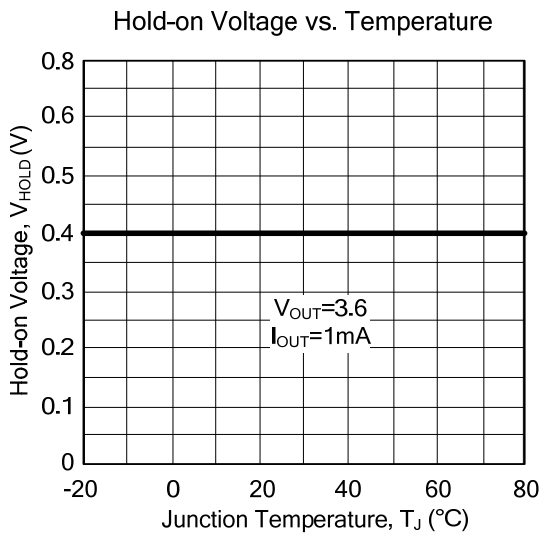
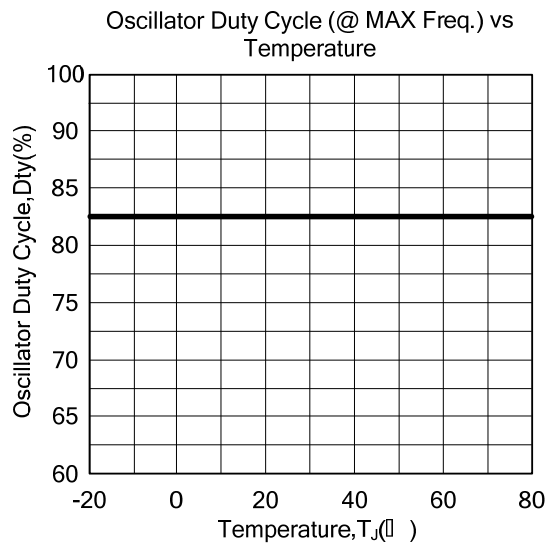
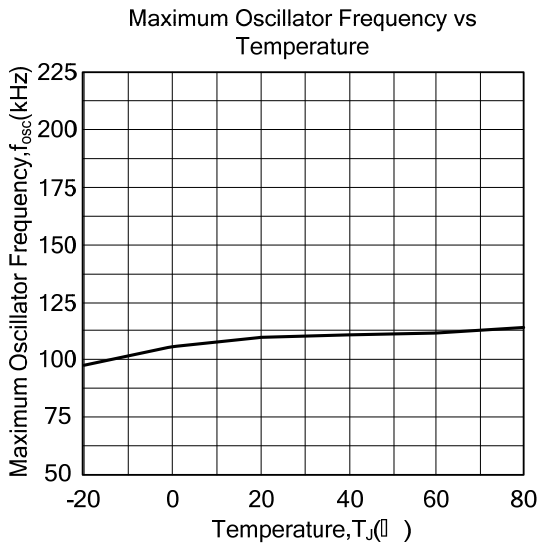
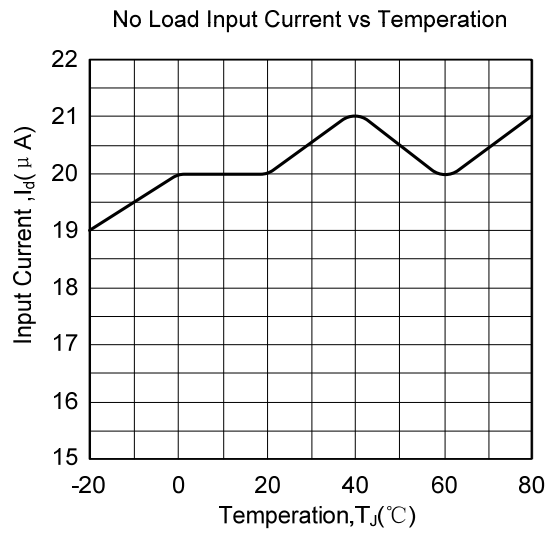
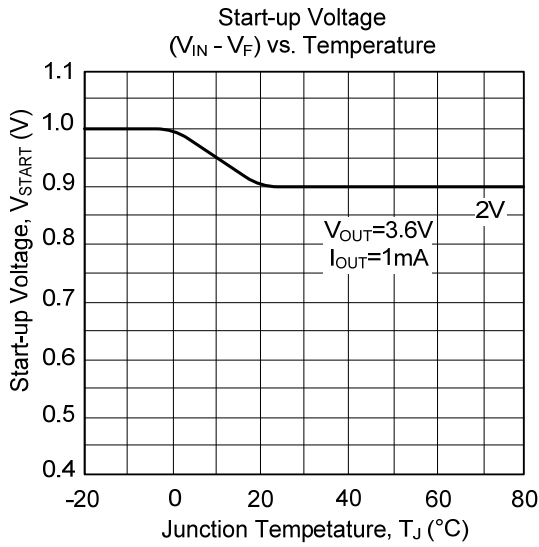



■ TYPICAL CHARACTERISTICS(Cont.)

Output Waveform of LX

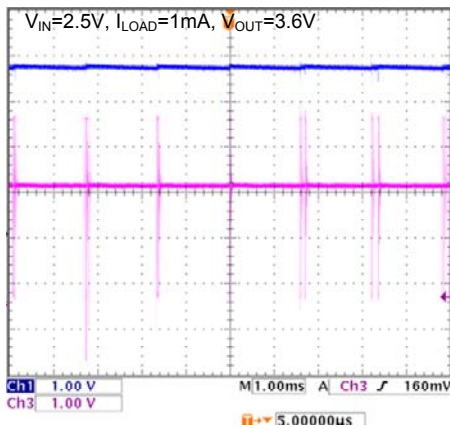

Upper Trace: Output Voltage, 1V/Division  
Lower Trace: LX Mode Voltage, 1V/Division

Output Waveform of LX

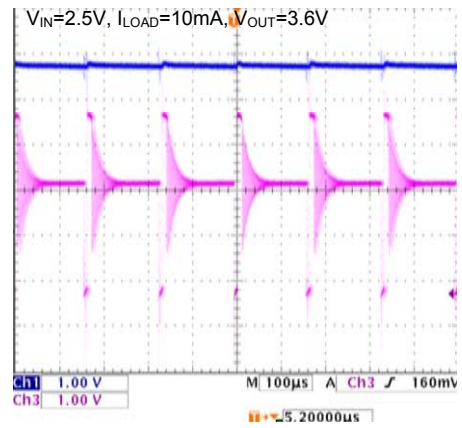

Upper Trace: Output Voltage, 1V/Division  
Lower Trace: LX Mode Voltage, 1V/Division

Output Waveform of LX

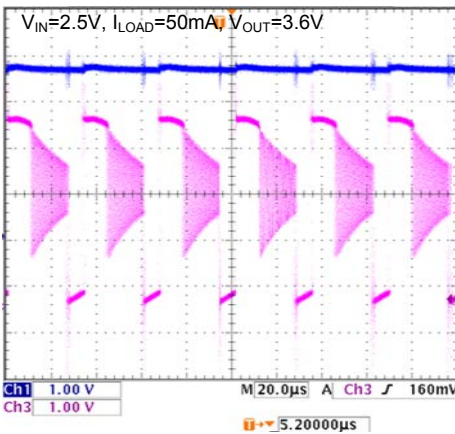

Upper Trace: Output Voltage, 1V/Division  
Lower Trace: LX Mode Voltage, 1V/Division

Output Waveform of LX

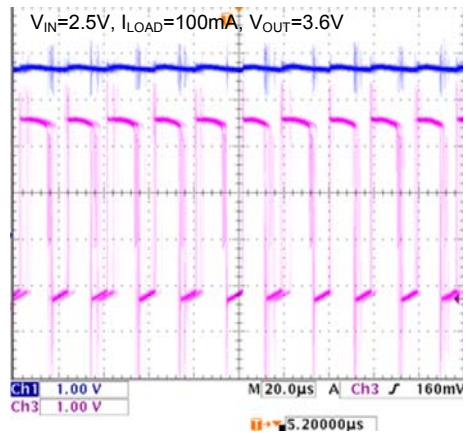

Upper Trace: Output Voltage, 1V/Division  
Lower Trace: LX Mode Voltage, 1V/Division

Output Waveform of LX

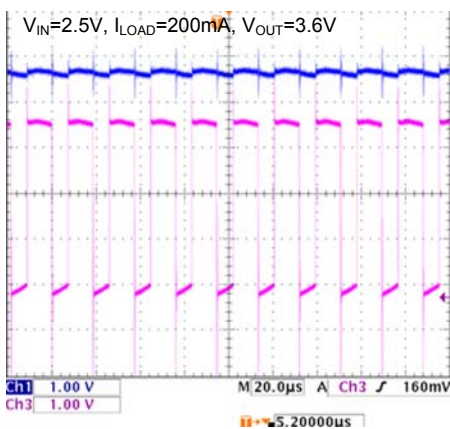

Upper Trace: Output Voltage, 1V/Division  
Lower Trace: LX Mode Voltage, 1V/Division

Output Waveform of LX Under Maximum Frequency

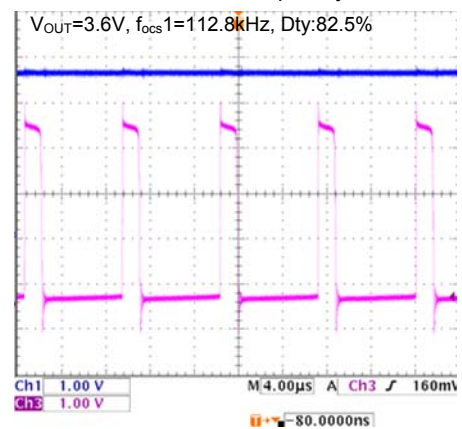

Upper Trace: Output Voltage, 1V/Division  
Lower Trace: LX Mode Voltage, 1V/Division

UTC assumes no responsibility for equipment failures that result from using products at values that exceed, even momentarily, rated values (such as maximum ratings, operating condition ranges, or other parameters) listed in products specifications of any and all UTC products described or contained herein. UTC products are not designed for use in life support appliances, devices or systems where malfunction of these products can be reasonably expected to result in personal injury. Reproduction in whole or in part is prohibited without the prior written consent of the copyright owner. The information presented in this document does not form part of any quotation or contract, is believed to be accurate and reliable and may be changed without notice.