



# 2SC3648

## NPN SILICON TRANSISTOR

### HIGH-VOLTAGE SWITCHING PREDRIVER APPLICATIONS

■ FEATURES

- \* High Breakdown Voltage and Large Current Capacity
- \* Fast Switching Speed
- \* Over Current Protection Function

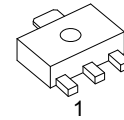

SOT-89

■ ORDERING INFORMATION

Ordering Number			Package	Pin Assignment			Packing
Normal	Lead Free	Halogen Free		1	2	3	
2SC3648-x-AB3-R	2SC3648L-x-AB3-R	2SC3648G-x-AB3-R	SOT-89	B	C	E	Tape Reel

<p>2SC3648L-x-AB3-R</p> <p>(1) Packing Type</p> <p>(2) Package Type</p> <p>(3) Rank</p> <p>(4) Lead Free</p>	<p>(1) R: Tape Reel</p> <p>(2) AB3: SOT-89</p> <p>(3) x: refer to Classification of <math>h_{FE}</math></p> <p>(4) G: Halogen Free, L: Lead Free Plating, Blank: Pb/Sn</p>
--	--

■ ABSOLUTE MAXIMUM RATING (Ta = 25°C)

PARAMETER	SYMBOL	RATINGS	UNIT
Collector to Base Voltage	$V_{CBO}$	180	V
Collector to Emitter Voltage	$V_{CEO}$	160	V
Emitter to Base Voltage	$V_{EBO}$	6	V
Collector Current	$I_C$	0.7	A
Collector Current (Pulse)	$I_{CP}$	1.5	A
Collector Dissipation	$P_C$	500	mW
Junction Temperature	$T_J$	150	°C
Storage Temperature	$T_{STG}$	-40 ~ +150	°C

Note: Absolute maximum ratings are those values beyond which the device could be permanently damaged.

Absolute maximum ratings are stress ratings only and functional device operation is not implied.

■ ELECTRICAL CHARACTERISTICS (Ta= 25°C, unless otherwise specified)

PARAMETER	SYMBOL	TEST CONDITIONS	MIN	TYP	MAX	UNIT
Collector-Base Breakdown Voltage	$BV_{CBO}$	$I_C = 10\mu A, I_E = 0$	180			V
Collector-Emitter Breakdown Voltage	$BV_{CEO}$	$I_C = 1, R_{BE} = \infty$	160			V
Emitter-Base Breakdown Voltage	$BV_{EBO}$	$I_E = 10\mu A, I_C = 0$	6			V
Collector Cutoff Current	$I_{CBO}$	$V_{CB} = 120V, I_E = 0$			0.1	$\mu A$
Emitter Cutoff Current	$I_{EBO}$	$V_{EB} = 4V, I_C = 0$			0.1	$\mu A$
Collector-Emitter Saturation Voltage	$V_{CE(SAT)}$	$I_C = 250mA, I_B = 25mA$		0.12	0.4	V
Base-Emitter Saturation Voltage	$V_{BE(SAT)}$	$I_C = 250mA, I_B = 25mA$		0.85	1.2	V
Output Capacitance	$C_{ob}$	$V_{CB} = 10V, f = 1MHz$		8		pF
DC Current Gain	$h_{FE1}$	$V_{CE} = 5V, I_C = 100mA$	100		400	
	$h_{FE2}$	$V_{CE} = 5V, I_C = 10mA$	90			
Turn-on Time	$t_{ON}$	See specified Test circuit		50		ns
Storage Time	$t_{STG}$	See specified Test circuit		1000		ns
Fall Time	$t_F$	See specified Test circuit		60		ns
Gain-Bandwidth Product	$f_T$	$V_{CE} = 5V, I_C = 50mA$		120		MHz

■ CLASSIFICATION OF  $h_{FE1}$

RANK	R	S	T
RANGE	100 ~ 200	140 ~ 280	200 ~ 400

## SWITCHING TIME TEST CIRCUIT

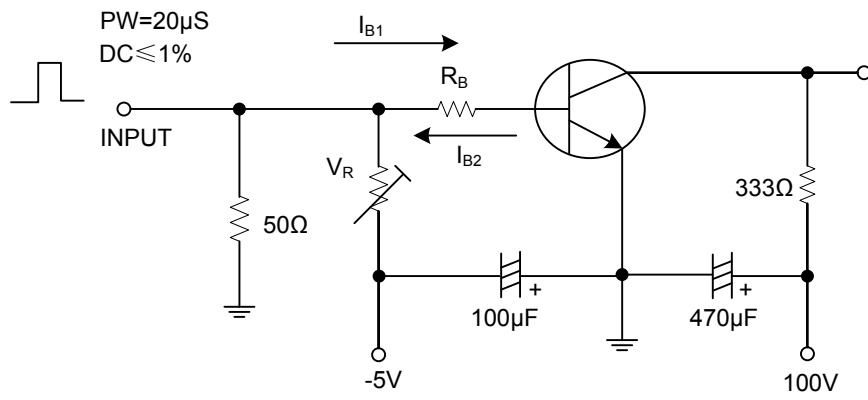

$$20I_{B1} = -20I_{B2} = I_C = 300\text{mA}$$

## ■ TYPICAL CHARACTERISTICS

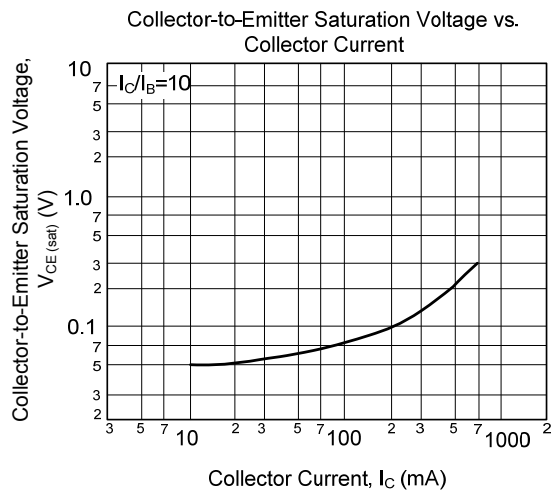
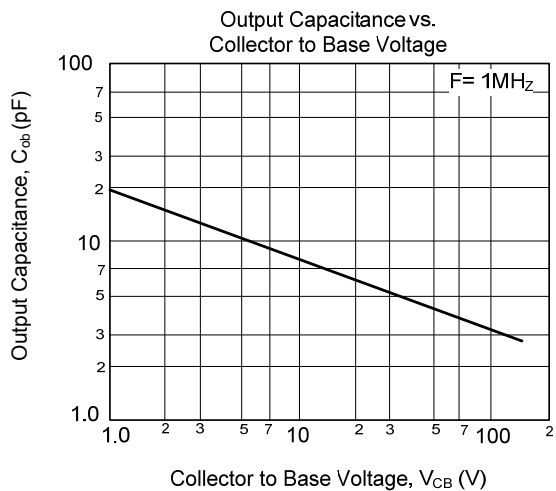
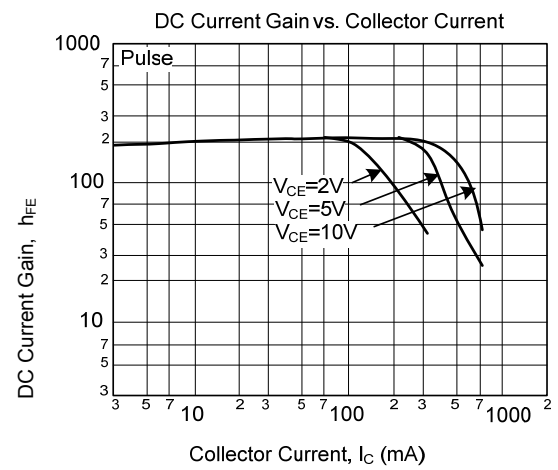
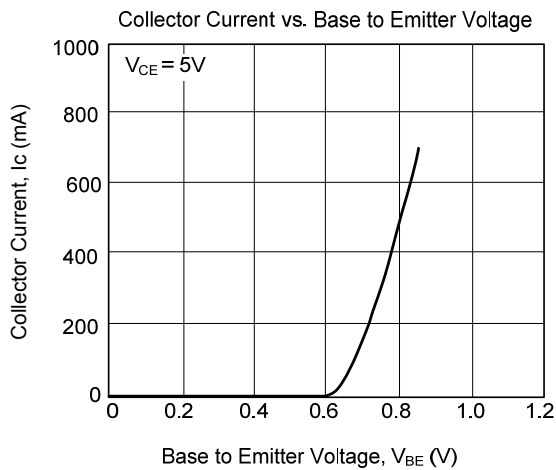
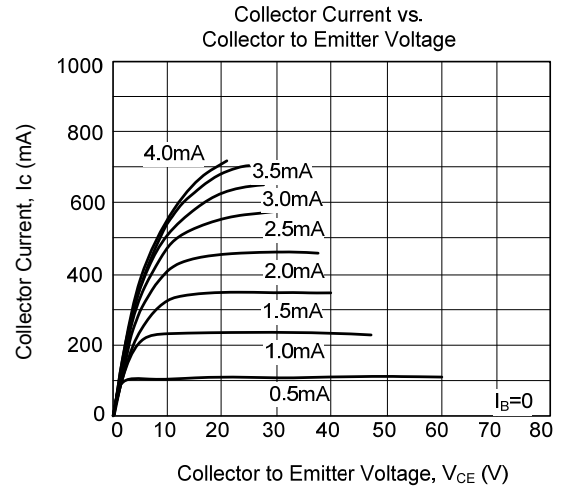
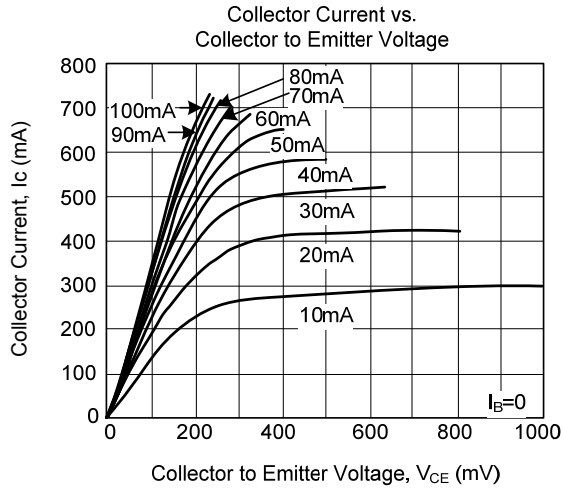

## TYPICAL CHARACTERISTICS(Cont.)

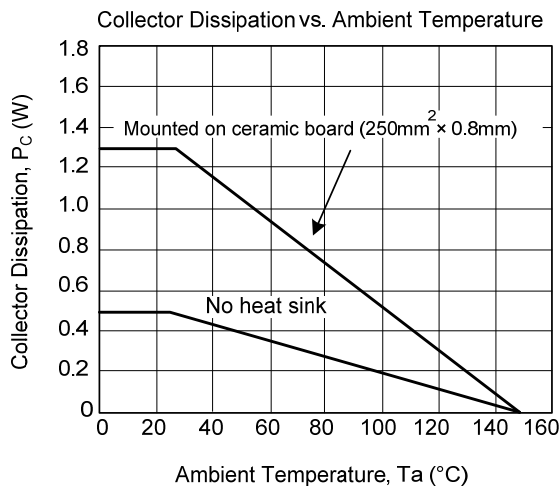
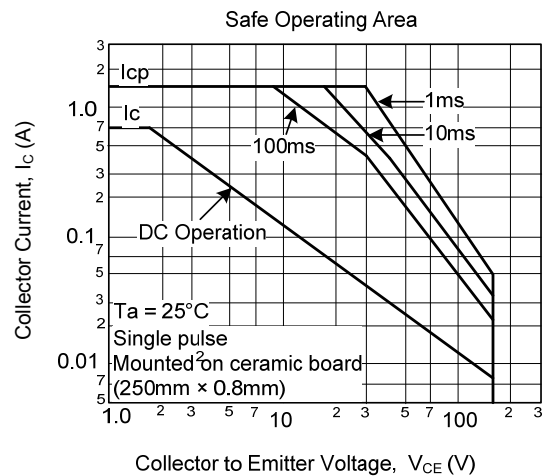
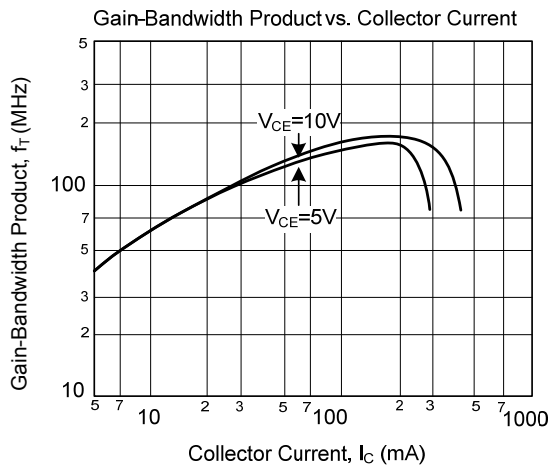

UTC assumes no responsibility for equipment failures that result from using products at values that exceed, even momentarily, rated values (such as maximum ratings, operating condition ranges, or other parameters) listed in products specifications of any and all UTC products described or contained herein. UTC products are not designed for use in life support appliances, devices or systems where malfunction of these products can be reasonably expected to result in personal injury. Reproduction in whole or in part is prohibited without the prior written consent of the copyright owner. The information presented in this document does not form part of any quotation or contract, is believed to be accurate and reliable and may be changed without notice.