

Single Output USN D5 Models

Non-Isolated, 5V_{IN}, 1.5-3.3V_{OUT}
8/10A DC/DC's in SIP Packages

Features

- Industry-standard SIP pinout
- Shorter (2.0" vs. 2.5") package length
- 4.5-5.5V input range
- 1.5/1.8/2.5/3.3V outputs @ 8 or 10 Amps
- Non-isolated, fully synchronous, 200kHz, buck topology
- Superior performance vs. competitors:
 - 8/10 Amps vs. 6 Amps
 - ±1% setpoint accuracy
 - Efficiencies to 91%
 - Noise as low as 25mVp-p
 - Stable no-load operation
 - Wide-range trimmable output voltage
- Remote on/off control; Optional sense pin
- Power-good pin and "Lucent-compatible" on/off control available
- EN60950 and UL1950 certified
- EMC compliant

DATEL's new USN D5 Series SIP's (single-in-line packages) are non-isolated DC/DC converters that accept a 5V input (4.5V to 5.5V input range) and deliver 1.5V, 1.8V, 2.5V or 3.3V outputs at either 8 or 10 Amps. USN D5 SIP's are designed to take on-board 5V power and convert it, with the highest efficiency in the smallest space, to any lower voltage required by today's current-hungry DSP's, ASIC's and CPLD's.

USN's are ideal for true point-of-use power processing. They occupy a mere 0.8 square inches of board space (2" length, 0.4" width, 0.53" height). Their fully synchronous, fixed-frequency (200kHz), buck topology delivers high efficiency (91% for 3.3V_{OUT} models), tight regulation (±0.1%/±0.5% line/load), stable no-load operation, and low output noise (25mVp-p for 1.5/1.8V_{OUT} models).

The fully functional USN's feature input undervoltage shutdown, output overcurrent detection, continuous short-circuit protection, a wide-range output-voltage trim function, a remote on/off control pin, and an optional sense pin.

USN's are pin compatible with similar devices from Lucent/Tyco, Artesyn Technologies and Power-One. USN's, however, deliver more current (10A vs. 6A), from a smaller package (2.0" vs. 2.5" long), with better accuracy (±1% max.), tighter regulation, less noise, and superior temperature performance. If a USN SIP is operated at only 6 Amps, for example, it can reliably operate up to +65°C (with 100lfm air flow).

If your low-voltage, high-current requirements have made the use of inefficient linear regulators impractical, take a look at one of DATEL's easy-to-use, low-cost USN SIP's. All devices are UL1950/EN60950 certified and EMC compliant. UL, CB and EMC reports are available upon request.

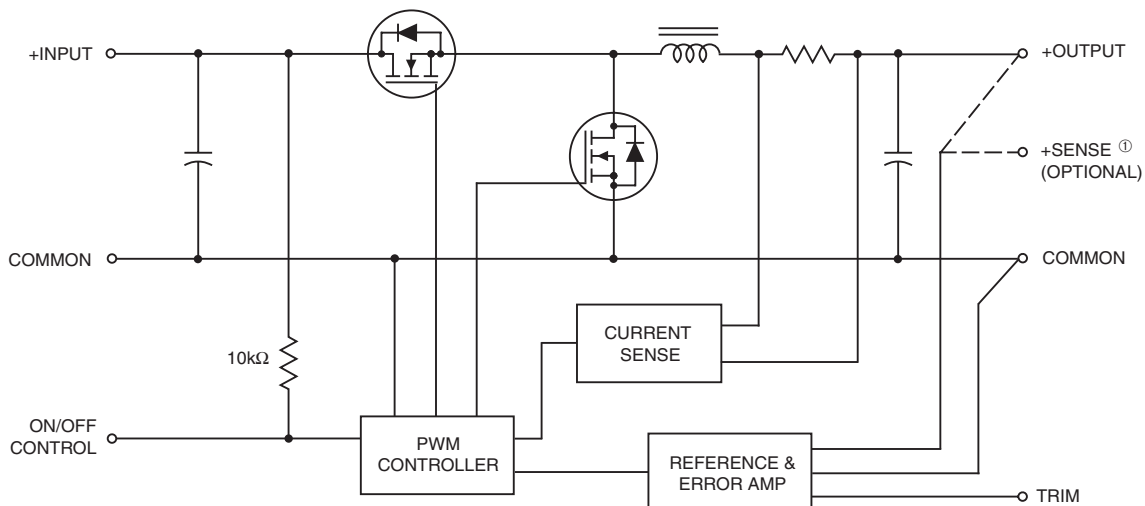

① For devices with the sense-pin option ("R" suffix), the feedback path is through the +Sense pin and not the +Output pin.

Figure 1. Simplified Schematic

Performance Specifications and Ordering Guide ^①

PRELIMINARY

Model	Output						Input			Efficiency		Package (Case, Pinout)
	V _{OUT} (Volts)	I _{OUT} (Amps)	R/N (mVp-p) ^②		Regulation (Max.)		V _{IN} Nom. (Volts)	Range (Volts)	I _{IN} ^④ (mA)	Min.	Typ.	
			Typ.	Max.	Line	Load ^③						
USN-1.5/8-D5	1.5	8	25	50	±0.1%	±0.625%	5	4.5-5.5	50/2890	80%	83%	B4, P50
USN-1.5/10-D5	1.5	10	25	50	±0.1%	±0.625%	5	4.5-5.5	50/3570	80%	84%	B4, P50
USN-1.8/8-D5	1.8	8	25	50	±0.1%	±0.625%	5	4.5-5.5	50/3430	80%	84%	B4, P50
USN-1.8/10-D5	1.8	10	25	50	±0.1%	±0.625%	5	4.5-5.5	50/4190	80%	86%	B4, P50
USN-2.5/8-D5	2.5	8	30	60	±0.1%	±0.5%	5	4.5-5.5	50/4550	85%	88%	B4, P50
USN-2.5/10-D5	2.5	10	30	60	±0.1%	±0.5%	5	4.5-5.5	50/5620	85%	89%	B4, P50
USN-3.3/8-D5	3.3	8	30	60	±0.1%	±0.5%	5	4.5-5.5	50/5800	87%	91%	B4, P50
USN-3.3/10-D5	3.3	10	30	60	±0.1%	±0.5%	5	4.5-5.5	50/7250	87%	91%	B4, P50

^① Typical at T_A = +25°C under nominal line voltage and full-load conditions, unless otherwise noted. All models are tested and specified with an external 220µF input capacitor with a 100mΩ ESR and a 1.28Arms ripple-current rating, as well as a 220µF output capacitor with a 100mΩ ESR. See I/O Filtering and Noise Reduction for details.

^② Ripple/Noise (R/N) is tested/specified over a 20MHz bandwidth. Output noise may be further reduced by installing additional external output capacitors. See I/O Filtering and Noise Reduction.

^③ These devices have no minimum load requirements and will regulate under no-load conditions.

^④ Nominal line voltage, no-load/full-load conditions.

PART NUMBER STRUCTURE

U **SN** - **1.8** / **10** - **D5** **R**

Output Configuration:
U = Unipolar

Non-Isolated SIP

Nominal Output Voltage:
1.5, 1.8, 2.5 or 3.3 Volts

Maximum Rated Output
Current in Amps

R Suffix:
Remote Sense
(Pin 3 installed)

Input Voltage Range:
D5 = 4.5 to 5.5 Volts (5V nominal)

TEMPERATURE DERATING

Temperature Derating for 8 Amp Models
V_{IN} = Nominal

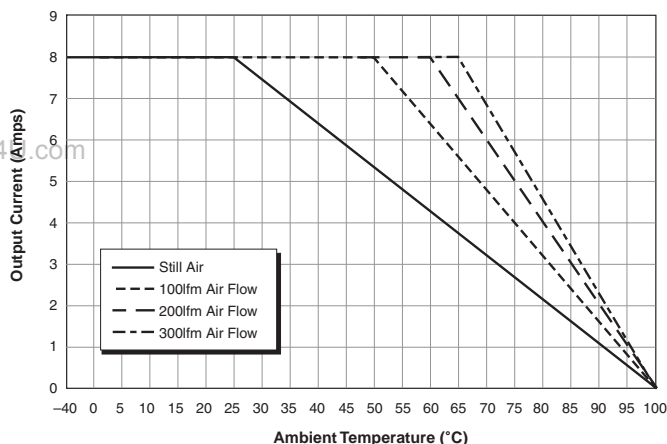

Temperature Derating for 10 Amp Models
V_{IN} = Nominal

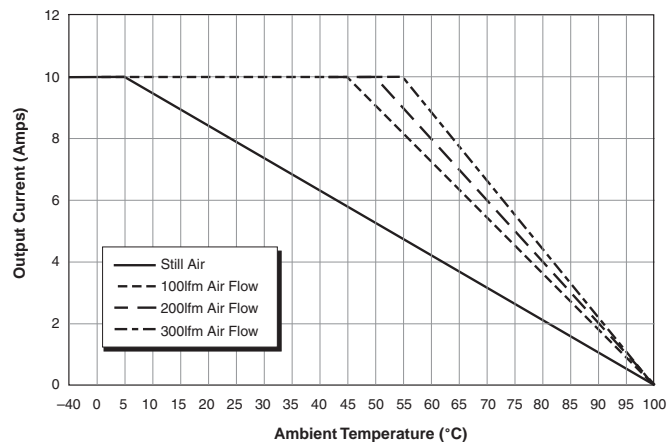

MECHANICAL SPECIFICATIONS

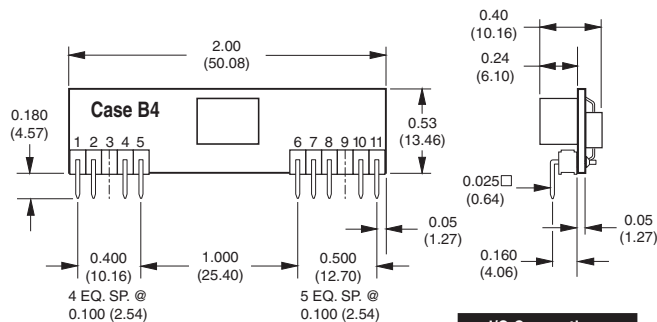

DIMENSIONS ARE IN INCHES (MM)

I/O Connections	
Pin	Function P50*
1	+Output
2	+Output
3	No Pin**
4	+Output
5	Common
6	Common
7	+Input
8	+Input
9	No Pin
10	Trim
11	On/Off Control

* See Functional Options in Technical Notes.

** Pin 3 (Sense) installed for R suffix models.

Performance/Functional Specifications

Typical @ $T_A = +25^\circ\text{C}$ under nominal line voltage and full-load conditions unless noted. ①

Input	
Input Voltage Range	4.5 to 5.5 Volts (5V nominal)
Input Current:	
Normal Operating Conditions	See Ordering Guide
Standby/Off Mode	50 μA typical, 200 μA maximum
Input Ripple Current	50mA _{p-p}
Input Filter Type	Capacitive (66 μF)
Overvoltage Protection	None
Reverse-Polarity Protection	None
Undervoltage Shutdown	3.2-3.9 Volts
On/Off Control ② ③	On = open or 2.4V to + V_{IN} , I _{IN} max. <400 μA Off = 0-0.8V, I _{IN} max. <600 μA
Output	
V_{OUT} Accuracy (50% load)	$\pm 1\%$ maximum
Minimum Loading ④	No load
V_{OUT} Trim Range: ②	
Trim pin tied to +Output:	
1.5V Models	TBD
1.8V Models	$V_{\text{OUT}} = 1.50$ Volts (-17%)
2.5V Models	$V_{\text{OUT}} = 1.77$ Volts (-29%)
3.3V Models	$V_{\text{OUT}} = 1.80$ Volts (-45%)
Trim pin tied to Common:	
1.5V Models	TBD
1.8V Models	$V_{\text{OUT}} = 3.0$ Volts (+67%)
2.5V & 3.3V Models	$V_{\text{OUT}} = 3.6$ Volts (+44% and +9%)
Ripple/Noise (20MHz BW) ⑤	See Ordering Guide
Line/Load Regulation	See Ordering Guide
Efficiency ②	See Ordering Guide
Overcurrent Detection and Short-Circuit Protection: ② ⑥	
Current-Limiting Detection Point:	
8 Amp Models	10-12 Amps
10 Amp Models	13-15 Amps
Short-Circuit Detection Point	<80% of rated output voltage
SC Protection Technique	Latched shutdown
Dynamic Characteristics	
Transient Response (50% load step)	50 μsec to $\pm 1.5\%$ of final value
Start-Up Time: ②	
V_{IN} to V_{OUT}	900 μsec
On/Off to V_{OUT}	1msec
Switching Frequency	200kHz ($\pm 28\text{kHz}$)
Environmental	
MTBF:	Bellcore, ground fixed, full power, 100lfm air flow
8A Outputs (+50°C air)	6 million hours
10A Outputs (+45°C air)	7 million hours
Operating Temperature: ② (Ambient, 100lfm air flow)	
Without Derating 8A/10A	-40 to +45/50°C
With Derating	to +100°C (See Derating Curves)
Storage Temperature	-40 to +105°C

Physical	
Dimensions	2" x 0.40" x 0.53" (50.8 x 10.2 x 13.5mm)
Package	Open-frame, single-in-line (SIP)
Pin:	
Material	0.025" (0.635mm) square bronze with tin-lead plate over nickel underplate
Length	0.180" (4.57mm)
Weight	0.3 ounces (8.5gm)
Flamability Rating	UL94V-0

① All models are tested and specified with an external 220 μF input capacitor with a 100m Ω ESR and a 1.28Arms ripple-current rating, as well as a 220 μF output capacitor with a 100m Ω ESR rating.

② See Technical Notes/Graphs for details.

③ The On/Off Control is designed to be driven with open-collector logic or the application of appropriate voltages (referenced to Common, pins 5 and 6). Applying a voltage to the On/Off Control pin (pin 11) when no input voltage is applied to the converter may cause permanent damage.

④ All models are stable and regulate within spec under no-load conditions.

⑤ Output noise may be further reduced with the installation of additional external output capacitors. See Technical Notes.

⑥ If an output short circuit results in a latched shutdown, the converter will have to be restarted by cycling either the input voltage or the On/Off Control pin.

Absolute Maximum Ratings

Input Voltage:	
Continuous	7 Volts
Transient (100msec)	8 Volts
On/Off Control Pin (pin 11)	7 Volts
Input Reverse-Polarity Protection	None
Output Overvoltage Protection	None
Output Current	Current limited. Devices can withstand sustained output short circuits without damage.
Storage Temperature	-40 to +105°C
Lead Temperature (soldering, 10 sec.)	+300°C

These are stress ratings. Exposure of devices to any of these conditions may adversely affect long-term reliability. Proper operation under conditions other than those listed in the Performance/Functional Specifications Table is not implied.

TECHNICAL NOTES

Return Current Paths

The USN 12-33W D5 SIP's are non-isolated DC/DC converters. Their two Common pins (pins 5 and 6) are connected to each other internally (see Figure 1). To the extent possible (with the intent of minimizing ground loops), input return current should be directed through pin 6 (also referred to -Input or Input Return), and output return current should be directed through pin 5 (also referred to as -Output or Output Return). Any on/off control signals applied to pin 11 (On/Off Control) should be referenced to Common (specifically pin 6).

I/O Filtering and Noise Reduction

All models in the USN 12-33W D5 Series are tested and specified with external 220 μF input capacitors (100m Ω ESR, 1.28Arms ripple-current rating) and external 220 μF (100m Ω ESR) output capacitors. In critical applications, input/output ripple/noise may be further reduced by installing additional, external I/O caps.

External input capacitors serve primarily as energy-storage devices. They should be selected for bulk capacitance (at appropriate frequencies), low ESR, and high rms-ripple-current ratings. The switching nature of modern DC/DC converters requires that the dc input voltage source have low ac impedance, and highly inductive source impedances can affect system stability. Your specific system configuration may necessitate additional considerations.

Output ripple/noise (also referred to as periodic and random deviations or PARD) can be reduced below specified limits using filtering techniques, the simplest of which is the installation of additional external output capacitors. Output capacitors function as true filter elements and should be selected for bulk capacitance, low ESR, and appropriate frequency response. Any scope measurements of PARD should be made directly at the DC/DC output pins with scope probe ground less than 0.5" in length.

All external capacitors should have appropriate voltage ratings and be located as close to the converters as possible. Temperature variations for all relevant parameters should be taken into consideration.

The most effective combination of external I/O capacitors will be a function of your line voltage and source impedance, as well as your particular load and layout conditions. Our Applications Engineers can recommend potential solutions and discuss the possibility of our modifying a given device's internal filtering to meet your specific requirements. Contact our Applications Engineering Group for additional details.

Input Fusing

USN 12-33W D5 SIP Series DC/DC converters are not internally fused. Certain applications and or safety agencies may require the installation of fuses at the inputs of power conversion components. For DATEL USN D5 SIP Series DC/DC's, you should use either slow-blow or normal-blow fuses with values no greater than the following.

Model	Fuse Value
USN-1.5/8-D5	6.5 Amps
USN-1.5/10-D5	7.5 Amps
USN-1.8/8-D5	7.5 Amps
USN-1.8/10-D5	9 Amps
USN-2.5/8-D5	10 Amps
USN-2.5/10-D5	12 Amps
USN-3.3/8-D5	12.5 Amps
USN-3.3/10-D5	15 Amps

Input Overvoltage and Reverse-Polarity Protection

USN D5 SIP Series DC/DC converters do not incorporate either input overvoltage or input reverse-polarity protection. Input voltages in excess of the listed absolute maximum ratings and input polarity reversals of longer than "instantaneous" duration can cause permanent damage to these devices.

On/Off Control

The On/Off Control pin may be used for remote on/off operation. USN D5 SIP Series DC/DC converters are designed so that they are enabled when the control pin is pulled high (+2.4V to +V_{IN} applied) or left open (normal mode) and disabled when the control pin is pulled low (to less than +0.8V relative to Common). As shown in Figure 2, all models have internal 10k Ω pull-up resistors to V_{IN} (+Input).

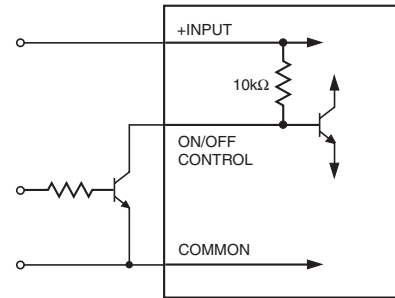

Figure 2. Driving the Standard On/Off Control Pin

Dynamic control of the on/off function is best accomplished with a mechanical relay or open-collector/open-drain drive circuit. The drive circuit should be able to sink appropriate current when activated and withstand appropriate voltage when deactivated.

Applying an external voltage to the On/Off Control pin when no input power is applied to the converter can cause permanent damage to the converter. The on/off control function, however, is designed such that the converter can be disabled (control pin pulled low) while input power (system 5V power) is ramping up and then "released" once the input has stabilized. The time duration between the point at which the converter is released and its fully loaded output settles to within specified accuracy can be found in the Performance/Functional Specifications Table. See Start-Up Time for more details.

The USN 12-33W D5 SIP Series converters are also available with a "Lucent compatible" on/off control function. (Contact DATEL for model numbers and availability.)

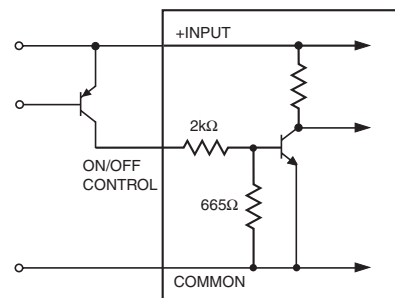

Figure 3. Driving the "Lucent Compatible" On/Off Control Pin

Start-Up Time

The V_{IN} to V_{OUT} Start-Up Time is the interval between the time at which a ramping input voltage crosses the lower limit of the specified input voltage range (4.5 Volts) and the fully loaded output voltage enters and remains within its specified accuracy band. Actual measured times will vary with input source impedance, external input capacitance, and the slew rate and final value of the input voltage as it appears to the converter.

The On/Off to V_{OUT} Start-Up Time assumes the converter is turned off via the Remote On/Off Control with the nominal input voltage already applied to the converter. The specification defines the interval between the time at which the converter is turned on and the fully loaded output voltage enters and remains within its specified accuracy band. See Typical Performance Curves for details

Output Overvoltage Protection

USN D5 SIP Series DC/DC converters do not incorporate output overvoltage protection. In the extremely rare situation in which the device's feedback loop is broken, the output voltage may run to excessively high levels ($V_{OUT} = V_{IN}$). If it is absolutely imperative that you protect your load against any and all possible overvoltage situations, voltage limiting circuitry must be provided external to the power converter.

Output Overcurrent Detection

Overloading the output of a power converter for an extended period of time will invariably cause internal component temperatures to exceed their maximum ratings and eventually lead to component failure. High-current-carrying components such as inductors, FET's and diodes are at the highest risk. USN D5 SIP Series DC/DC converters incorporate an output overcurrent detection and shutdown function that serves to protect both the power converter and its load.

When the output current exceeds the maximum rating by 20% (typical) to 35% (maximum), the internal overcurrent-detection circuit limits output current. If the overload condition forces V_{OUT} to fall below 80% of rated output, the short-circuit detection circuit will latch the DC/DC into an off state. The latched condition can be reset by cycling the input voltage to the converter or by cycling the On/Off Control pin.

Output Voltage Trimming

Allowable trim ranges for each model in the USN D5 SIP Series are listed in the Performance/Functional Specifications table. Trimming is accomplished with either a trimpot or a single fixed resistor. The trimpot should be connected between +Output and Common with its wiper connected to the Trim pin as shown in Figure 4 below.

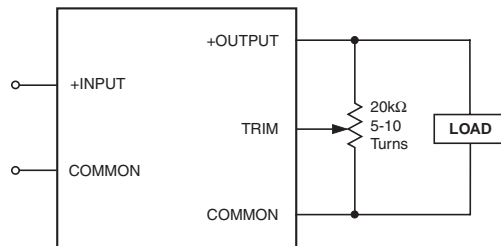
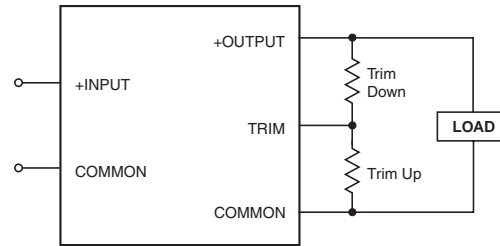

Figure 4. Trim Connections Using a Trimpot

A trimpot can be used to determine the value of a single fixed resistor which should be connected, as shown in Figure 5, between the Trim pin and +Output to trim down the output voltage, or between the Trim pin and Common to trim up the output voltage. Fixed resistors should have absolute TCR's less than 100ppm/°C to ensure stability.

The equations below can be used as starting points for selecting specific trim-resistor values. Recall that untrimmed devices are guaranteed to be $\pm 1\%$ accurate.



Note: Install either a fixed trim-up resistor or a fixed trim-down resistor depending upon desired output voltage.

Figure 5. Trim Connections Using Fixed Resistors

USN-1.8/8-D5, USN-1.8/10-D5 Trim Equations

$$R_{T_DOWN} (k\Omega) = \frac{2.55(V_O - 1.23)}{1.8 - V_O} - 2.21$$

$$R_{T_UP} (k\Omega) = \frac{3.14}{V_O - 1.8} - 2.21$$

USN-2.5/8-D5, USN-2.5/10-D5 Trim Equations

$$R_{T_DOWN} (k\Omega) = \frac{5.677(V_O - 1.23)}{2.5 - V_O} - 4.42$$

$$R_{T_UP} (k\Omega) = \frac{6.983}{V_O - 2.5} - 4.42$$

USN-3.3/8-D5, USN-3.3/10-D5 Trim Equations

$$R_{T_DOWN} (k\Omega) = \frac{4.46(V_O - 1.24)}{3.3 - V_O} - 1.74$$

$$R_{T_UP} (k\Omega) = \frac{5.512}{V_O - 3.3} - 1.74$$

Note: Resistor values are in kΩ. Accuracy of adjustment is subject to tolerances of resistors and factory-adjusted, initial output accuracy.
 V_O = desired output voltage.

Functional Options

USN Series SIP's have been designed so that a "Power-Good" function can be installed on Pin 9 (Contact DATEL). Standard models do not have a pin in the Pin 9 position.

Also, the standard polarity of the USN's On/Off Control function (pin 11 open or pulled high = on) complies with industry standards. Nevertheless, it is not compatible with the on/off polarity of the Lucent/Tyco NH020 Series SIP's (pin 9 open = off). Please contact DATEL if you would like us to modify devices to be Lucent compatible.

Remote Sense (Option)

USN D5 SIP Series DC/DC converters offer a sense option (pin 3) to assist in point-of-use regulation, by overcoming moderate IR drops in conductors or cabling. Since these are non-isolated devices, which generally utilize a ground plane, sense is only provided for the +Output.

The remote sense line, which is part of the feedback control-loop regulating the output, carries very little current and therefore requires a minimal cross sectional area conductor. As such, it is not a low impedance point and must be treated with care in layout and cabling. Sense lines should be run adjacent to signals—preferably ground. In cables and discrete wiring applications, twisted pair or other techniques should be implemented.

Note: For "R-suffix" models, the +Output and +Sense lines are not internally connected to each other. Therefore, if the sense function is not used for remote regulation, the user must connect the +Sense to +Output at the DC/DC converter pins.

The sense function is capable of compensating for voltage drops between the +Output and +Sense pins that do not exceed 10% of V_{out} .

$$[V_{out(+)} - \text{Common}] - [\text{Sense}(+) - \text{Common}] \leq 10\%V_{out}$$

Power derating is based on maximum output current and voltage at the converter's output pins. Use of trim and sense functions can cause output voltage to increase, thereby increasing output power beyond the USN's specified rating. Therefore:

$$(V_{out \text{ at pins}}) \times (I_{out}) \leq \text{rated output power}$$

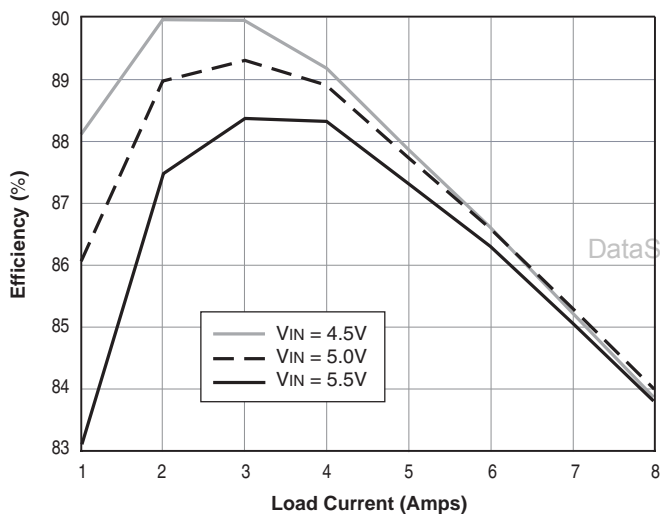
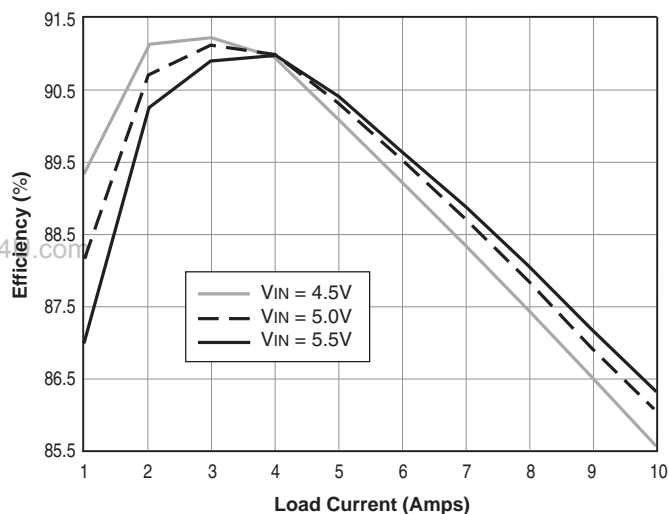
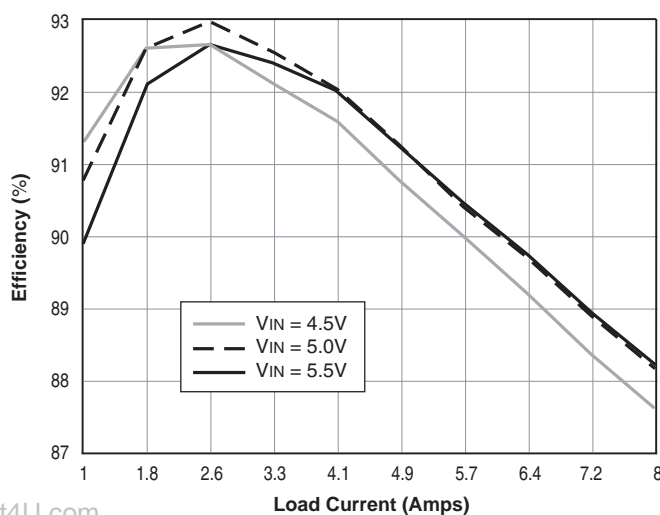
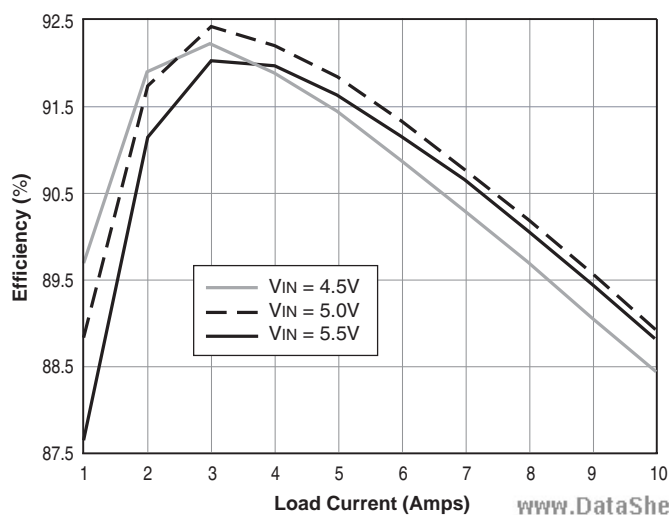
Typical Performance Curves**USN-1.8/8-D5 Efficiency vs. Line and Load****USN-1.8/10-D5 Efficiency vs. Line and Load****USN-2.5/8-D5 Efficiency vs. Line and Load****USN-2.5/10-D5 Efficiency vs. Line and Load**

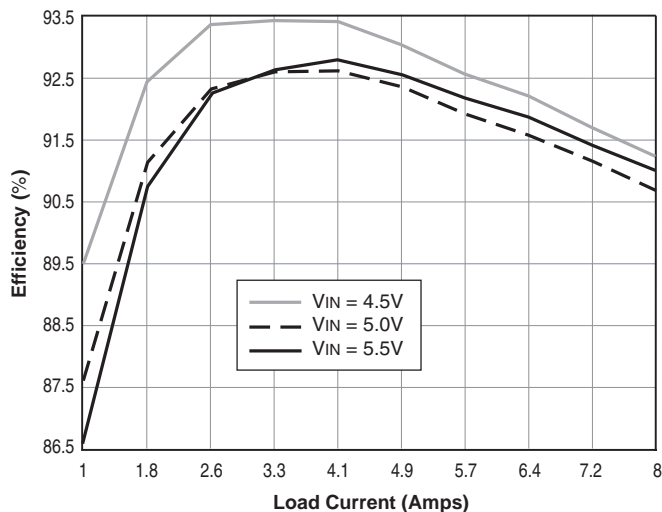
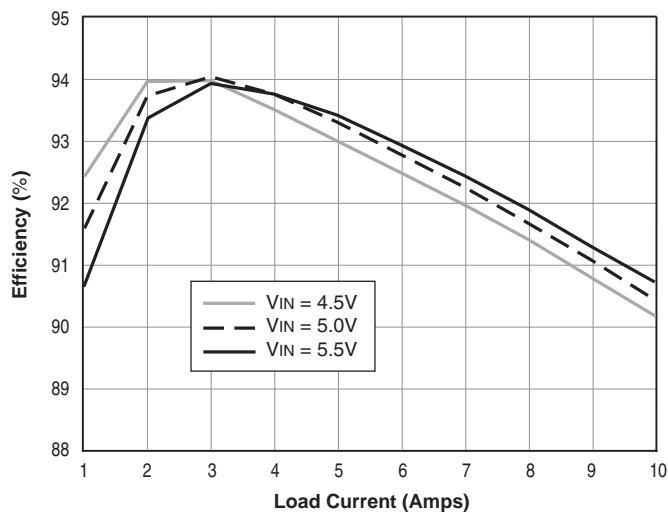
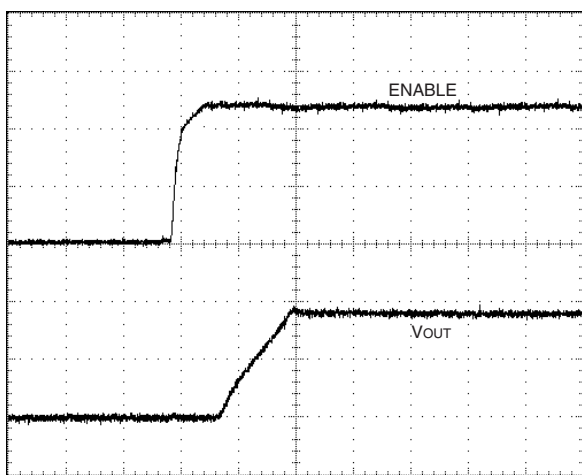
Typical Performance Curves**USN-3.3/8-D5 Efficiency vs. Line and Load****USN-3.3/10-D5 Efficiency vs. Line and Load****Typical Start-Up from Enable**(VIN = nominal, Full-load, 220 μ F input capacitor, 220 μ F output capacitor.)**Typical Start-Up from VIN**(VIN = nominal, Full-load, 220 μ F input capacitor, 220 μ F output capacitor.)