

8-INPUT DIGITAL MULTIPLEXER

8230/31/32/82S30/S31

DESCRIPTION

The 8-Input Digital Multiplexer is the logical equivalent of a single-pole, 8 position switch whose position is specified by a 3-bit input address.

The 8230 incorporates an INHIBIT input which, when LOW, allows the one-of-eight inputs selected by the address to appear on the f output and, in complement, on the \bar{f} output. With the INHIBIT input HIGH, the f output is unconditionally LOW and the \bar{f}

output is unconditionally HIGH. The 8230 is a functional and pin-for-pin replacement for the 9312.

The 8231 is a variation of the 8230 that provides open collector output \bar{f} for expansion of input terms. The 8232 is similar to the 8230 except in the effect of the INHIBIT input on the \bar{f} output. With the INHIBIT input LOW, the selected input appears at the f output and, in complement, on the \bar{f} output. With the INHIBIT input HIGH, both the f and the \bar{f} output are unconditionally LOW.

ORDERING CODE (See Section 9 for further Package and Ordering Information)

PACKAGES	COMMERCIAL RANGES $V_{CC} = 5V \pm 5\%$; $T_A = 0^\circ C$ to $75^\circ C$	MILITARY RANGES $V_{CC} = 5V \pm 5\%$; $T_A = -55^\circ C$ to $125^\circ C$
Plastic DIP	N8230N • N8231N • N8232N N82S30N • N82S31N	
Ceramic DIP	N8230F • N8231F • N8232F N82S30F • N82S31F	S8230F • S8231F • S8232F S82S30F • S82S31F
Flatpak		S8230W • S8231W

TRUTH TABLE

ADDRESS			DATA INPUTS								OUTPUT			
A ₂	A ₁	A ₀	I ₇	I ₆	I ₅	I ₄	I ₃	I ₂	I ₁	I ₀	INH	f	8230/ 82S30 8231/ 82S31 \bar{f}	8232 \bar{f}
L	L	L	x	x	x	x	x	x	x	H	L	H	L	L
L	L	H	x	x	x	x	x	x	H	x	L	H	L	L
L	H	L	x	x	x	x	x	H	x	x	L	H	L	L
L	H	H	x	x	x	x	H	x	x	x	L	H	L	L
H	L	L	x	x	x	H	x	x	x	x	L	H	L	L
H	L	H	x	x	H	x	x	x	x	x	L	H	L	L
H	H	L	x	H	x	x	x	x	x	x	L	H	L	L
H	H	H	H	x	x	x	x	x	x	x	L	H	L	L
L	L	L	x	x	x	x	x	x	L	L	L	L	H	H
L	L	H	x	x	x	x	x	L	x	x	L	L	H	H
L	H	L	x	x	x	L	x	x	x	L	L	L	H	H
L	H	H	x	x	x	x	x	x	x	L	L	L	H	H
H	L	L	x	L	x	x	x	x	x	L	L	L	H	H
H	L	H	x	L	x	x	x	x	x	L	L	L	H	H
H	H	L	x	L	x	x	x	x	x	L	L	L	H	H
H	H	H	L	x	x	x	x	x	x	L	L	L	H	H
x	x	x	x	x	x	x	x	x	x	H	L	H	L	L

L LOW voltage level
H HIGH voltage level
x Don't care

PIN CONFIGURATION

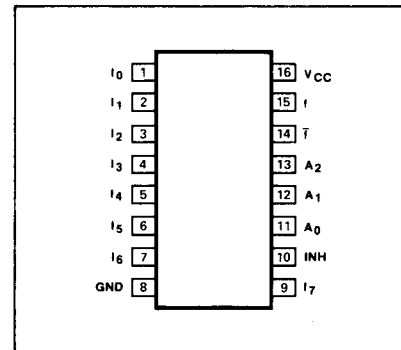

LOGIC DIAGRAMS

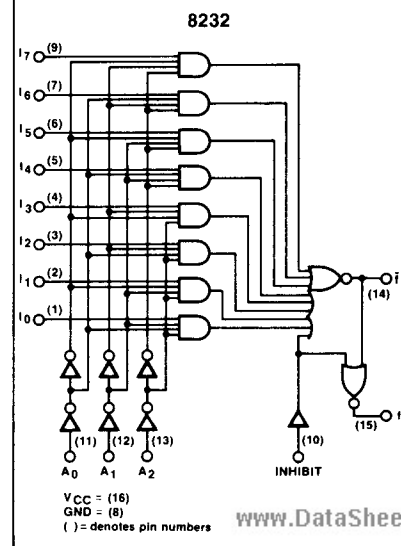
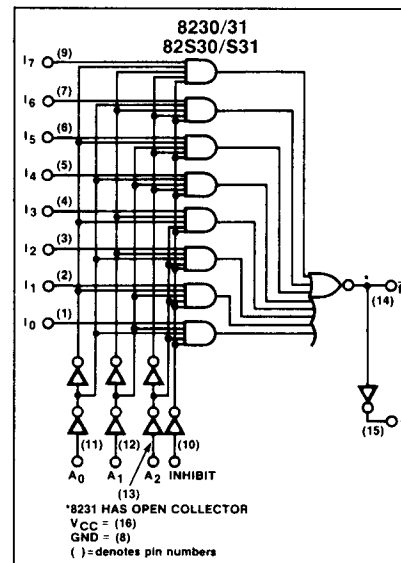

DC ELECTRICAL CHARACTERISTICS

PARAMETER	TEST CONDITIONS	8230/31/32			UNIT
		Min	Typ	Max	
V _{OH} Output HIGH voltage	V _{CC} = 4.75V, I _{OH} = -800 μ A	2.6	3.5		V
I _{OH} Output HIGH current f output of 8231 only	V _{CC} = 4.75V, V _{OUT} = 4.5V			150	μ A
V _{OL} Output LOW voltage	V _{CC} = 4.75V, I _{OL} = 16mA			0.4	V
I _{IH} Input HIGH current A _n , I _n (all) INH (all)	V _{CC} = 5.25V, V _{IN} = 4.5V			40 80	μ A μ A
I _{IL} Input LOW current A _n , I _n , INH (8230, 8231) INH (8232)	V _{CC} = 5.25V, V _{IN} = 0.4V	-0.1 -0.1		-1.6 -3.2	mA mA
V _{BD} Input voltage rating	V _{CC} = 4.75V, I _{IN} = 10mA	5.5			V
I _{OS} Output short circuit current	V _{CC} = 5V, V _{OUT} = 0V	-20		-70	mA
I _{CC} Supply current 8230, 8231 8232	V _{CC} = 5.25V		35 33	47.7 50	mA mA

DC ELECTRICAL CHARACTERISTICS (Cont'd)

PARAMETER	TEST CONDITIONS	82S30/82S31			UNIT
		Min	Typ	Max	
V _{OH} Output HIGH voltage	V _{CC} = 4.75V, I _{OH} = -1.0mA	2.7			V
I _{OH} Output HIGH current f Output of 82S31 only	V _{CC} = 4.75V, V _{OUT} = 4.5V			250	μ A
V _{OL} Output LOW voltage	V _{CC} = 4.75V, I _{OL} = 20mA			0.5	V
I _{IH} Input HIGH current	V _{CC} = 5.25V, V _{IN} = 4.5V			10	μ A
I _{IL} Input LOW current	V _{CC} = 5.25V, V _{IN} = 0.5V			-400	μ A
V _{CD} Input clamp voltage	V _{CC} = 4.75V, I _{IN} = -18mA			-1.2	V
I _{OS} Output short circuit current	V _{CC} = 5.25V, V _{OUT} = 0V	-40		-100	mA
I _{CC} Supply current	V _{CC} = 5.25V			62	mA

AC CHARACTERISTICS

PARAMETER	TEST CONDITIONS	8230		8231		8232		UNIT
		Typ	Max	Typ	Max	Typ	Max	
t_{PLH}	Propagation delay A_n to \bar{f} output	19	30	19	30	19	30	ns
t_{PHL}	A_n to f output	19	30	19	30	19	30	ns
t_{PLH}	Propagation delay I_n to \bar{f} output	13	20	15	24	13	20	ns
t_{PHL}	I_n to f output	13	20	15	24	13	20	ns
Δt_{PLH}	Prop. delay difference \bar{f} output to f output	10	15	10	15	10	15	ns
Δt_{PHL}	\bar{f} output to f output	10	15	10	15	10	15	ns
t_{PLH}	Propagation delay INH to \bar{f} output	18	30	18	30	13	20	ns
t_{PHL}	INH to f output	18	30	18	30	13	20	ns
t_{PLH}	Propagation delay INH to \bar{f} output					13	20	ns
t_{PHL}	INH to f output					13	20	ns

AC CHARACTERISTICS (Cont'd)

PARAMETER	TEST CONDITIONS	82S30		82S31		UNIT
		Typ	Max	Typ	Max	
t_{PLH}	Propagation delay A_n to \bar{f} output	14	17	16	19	ns
t_{PHL}	A_n to f output	14	17	16	19	ns
t_{PLH}	Propagation delay I_n to \bar{f} output	7.0	10	9.0	12	ns
t_{PHL}	I_n to f output	7.0	10	9.0	12	ns
Δt_{PLH}	Prop. delay difference \bar{f} output to f output	6.0	9.0	6.0	9.0	ns
Δt_{PHL}	\bar{f} output to f output	6.0	9.0	6.0	9.0	ns
t_{PLH}	Propagation delay INH to \bar{f} output	12	16	14	18	ns
t_{PHL}	INH to f output	12	16	14	18	ns
t_{PLH}	Propagation delay INH to \bar{f} output		26		28	ns
t_{PHL}	INH to f output		26		28	ns

NOTE

a. $C_L = 30\text{pF}$ for 82; $C_L = 15\text{pF}$ for 82S

AC TEST FIGURE

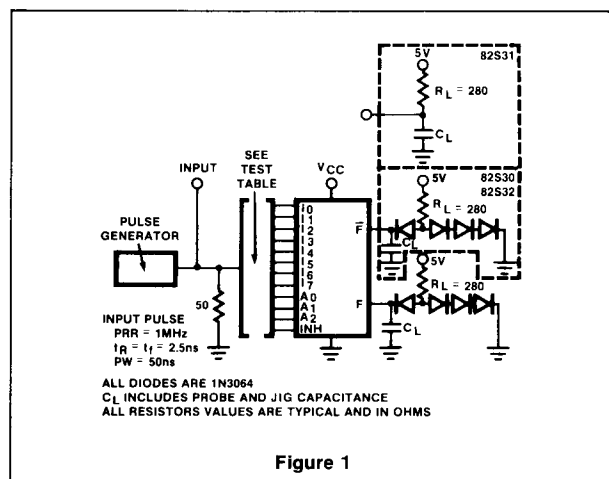

AC WAVEFORMS

