

## INTRODUCTION

The KS1461 receives optical signals from the optical pickup and makes the data-generation RF (Radio Frequency) signals needed in the system part, and the servo error signal and monitor signals, needed for stable servo control. The modes to which this RF IC can be applied are the CD 1×, 2×, 4×, and 8× modes (Wide PLL +/- 20%) and the DVD 1× and 2× CLV (Constant Linear Velocity) modes.

## FEATURES

- Compatible to play back of CDs at 1×, 2×, 4×, or 8×, and DVDs at 1× and 2×
- Can deal with all of CD-R corresponding P/U's optical signal input without additional circuits
- Built-in PreAmp that correspond to various P/U unit and gain controllable
- Built-in AGC (Automatic Gain Control) circuit for intensity radiation detection feedback
- RF AMP & equalizer for CD 1×, 2×, 4×, 8× and DVD 1×, and 2× compatibility
- Astigmatism FE (Focus Error) AMP for CD and DVD built-in
- TE (Tracking Error) AMP built-in for 3-beam method of CD
- TE (Tracking Error) AMP built-in to the 1-beam DPD (Differential Phase Detector) for DVD
- RF mirror detection circuit built-in for CD and DVD
- RF defect detection circuit built-in for CD and DVD
- FOK (Focus O.K) signal detection circuit built-in for CD and DVD
- Built-in RF envelope signal generator circuit for CD and DVD
- Built-in ALPC (Automatic Laser Power Control) circuit for CD and DVD
- Built-in standard voltage generating circuit for analog circuit
- Built-in detection circuit for abnormal wave forms
- Built-in Auto Offset compensation circuit
- Range of power in operation: 4.5 ~ 5.5V
- 100 PIN, TQFP (0.5 mm PITCH)

BLOCK DIAGRAM

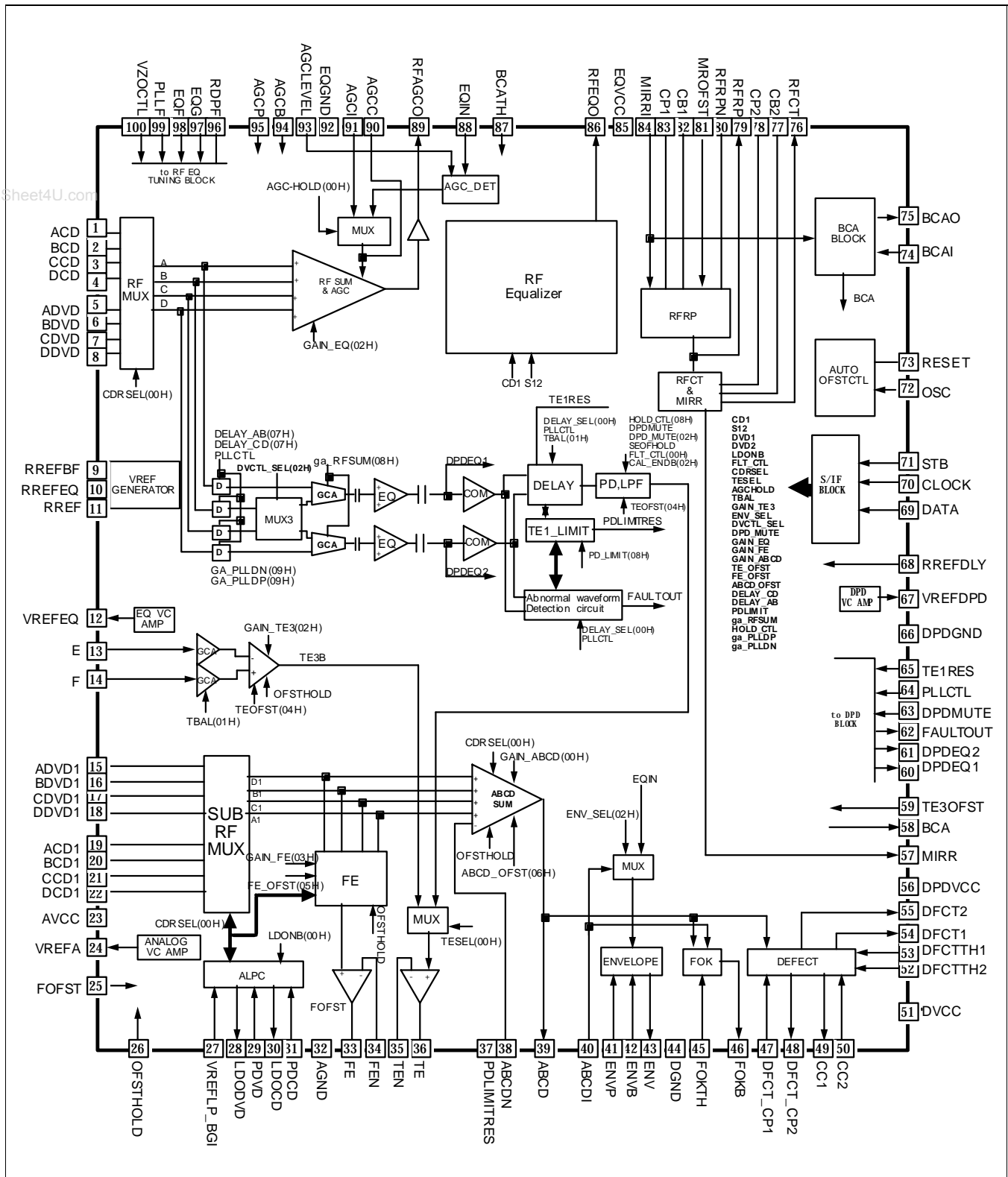

## PIN DESCRIPTION

Table 1. Pin Description

Pin No.	Pin Name	I/O	Description	Related Block	Related Part
1	ACD	I	Optical main beam A, AC Coupling input terminals for CD of RF block	PRE AMP	P/U
2	BCD	I	Optical main beam B, AC Coupling input terminals for CD of RF block	PRE AMP	P/U
3	CCD	I	Optical main beam C, AC Coupling input terminals for CD of RF block	PRE AMP	P/U
4	DCD	I	Optical main beam D, AC Coupling input terminals for CD of RF block	PRE AMP	P/U
5	ADVD	I	Optical main beam A, AC Coupling input terminals for DVD of RF block	PRE AMP	P/U
6	BDVD	I	Optical main beam B, AC Coupling input terminals for DVD of RF block	PRE AMP	P/U
7	CDVD	I	Optical main beam C, AC Coupling input terminals for DVD of RF block	PRE AMP	P/U
8	DDVD	I	Optical main beam D, AC Coupling input terminals for DVD of RF block	PRE AMP	P/U
9	RREFBF	-	RF AMP I/O buffer bias resistance connection terminal	RF AMP	-
10	RREFEQ	-	RF EQ BIAS resistance connection terminal	RF EQ	-
11	RREF	-	Analog Block bias resistance connection terminal	ANALOG	-
12	VREFEQ	-	CAP connection terminal for RF EQ Center voltage	EQ VC AMP	-
13	E	I	CD Optical sub beam E input terminal for Servos	TE 3B	P/U
14	F	I	CD Optical sub beam F input terminal for Servos	TE 3B	P/U
15	ADVD1	I	Optical main beam A input terminal for DVD of Servo block	SERVO AMP	P/U
16	BDVD1	I	Optical main beam B input terminal for DVD of Servo block	SERVO AMP	P/U
17	CDVD1	I	Optical main beam C input terminal for DVD of Servo block	SERVO AMP	P/U
18	DDVD1	I	Optical main beam D input terminal for DVD of Servo block	SERVO AMP	P/U
19	ACD1	I	Optical main beam A input terminal for CD of Servo block	SERVO AMP	P/U
20	BCD1	I	Optical main beam B input terminal for CD of Servo block	SERVO AMP	P/U
21	CCD1	I	Optical main beam C input terminal for CD of Servo block	SERVO AMP	P/U
22	DCD1	I	Optical main beam D input terminal for CD of Servo block	SERVO AMP	P/U
23	AVCC	P	Power voltage input terminal for Analog Part	ANALOG	-
24	VREFA	I/O	CAP connection terminal for Analog Part center voltage Uses an external block	ANA VC AMP	SERVO
25	FOFST	-	CAP connection terminal (open) for Focus Auto Offsets	FE AMP	-
26	OFSTHOLD	I	On/Off terminal for Auto Offset Block. (L: Auto Offset Adjustments, H: Serial Offset Adjustments)	OFSTCTL	MICOM

Table 1. Pin Description

Pin No.	Pin Name	I/O	Description	Related Block	Related Part
27	VREFLP_BGI	I	Band gap voltage input block for ALPC	ALPC	-
28	LDODVD	O	Optical Laser Diodes operation voltage output terminal for DVD	ALPC	P/U
29	PDDVD	I	Optical Laser Monitor Diode voltage input terminal for DVD	ALPC	P/U
30	LDOCD	O	Optical Laser Diode operating voltage output terminal for CD	ALPC	P/U
31	PDCD	I	Optical Laser Monitor Diode voltage input terminal for CD	ALPC	P/U
32	AGND	P	Power GND terminal for Analog Part	ANALOG	-
33	FE	O	FE AMP output terminal	FE AMP	DSSP
34	FEN	I	Input terminal for selecting FE AMP Gain	FE AMP	-
35	TEN	I	Input terminal for selecting TE AMP Gain	TE AMP	-
36	TE	O	TE AMP output terminal	TE AMP	DSSP
37	PDLIMITRES	-	Bias resistance terminal for PDLIMIT	DPD	-
38	ABCDN	I	ABCD AMP for selecting Gain (-) input terminal	ABCD AMP	-
39	ABCD	O	ABCD AMP output terminal	ABCD AMP	-
40	ABCDI	I	ABCD AC Coupling input terminal for servo monitor	SERVO MONIT	-
41	ENVP	-	CAP connection terminal for selecting the RC value of Peak Hold for detecting RF Envelopes	RF ENV	-
42	ENVB	-	CAP connection terminal for selecting the RC value of Bottom Hold for detecting RF Envelopes	RF ENV	-
43	ENV	O	RF Envelope Detect Output terminal	RF ENV	DSSP
44	DGND	P	Power GND input terminal for digital circuits	DIGITAL	-
45	FOKTH	I	Focus OK comparing level input terminal	FOKB	-
46	FOKB	O	Focus OK comparator output terminal (L: Focus OK)	FOKB	DSSP
47	DFCT_CP1	-	Connection terminal for RC value of Peak Hold, for selecting the maximum time for Servo signal	DFCT	-
48	DFCT_CP2	-	Connection terminal for RC value of Peak Hold, for selecting the minimum defect time for PLL	DFCT	-
49	CC1	O	Peak Hold Output terminal for selecting the minimum Defect time for Defect	DFCT	-
50	CC2	I	Peak Hold AC Coupling Input terminal for Defect	DFCT	-
51	DVCC	P	Power voltage input terminal for digital circuit	DIGITAL	-
52	DFCTTH2	-	Resistance connection terminal for selecting the Defect Comparating Level for PLL	DEFECT	-
53	DFCTTH1	-	Resistance connection terminal for selecting the Defect Comparating Level for Servo	DEFECT	-
54	DFCT1	O	Defect output terminal for Servo	DEFECT	DSSP
55	DFCT2	O	Defect output terminal for PLL	DEFECT	PLL
56	DPDVCC	P	Power voltage input terminal for DPD TE	DPD	-
57	MIRR	O	Mirror output terminal	MIRR	DSSP
58	BCA	O	BCA output terminal	BCA	DSP

Table 1. Pin Description

Pin No.	Pin Name	I/O	Description	Related Block	Related Part
59	TE3OFST	-	Cap connection terminal (open) for 3B TE Offset	3B TE AMP	-
60	DPDEQ1	O	DPD EQ (A+C) output terminal	DPD	-
61	DPDEQ2	O	DPD EQ (B+D) output terminal	DPD	-
62	FAULTOUT	O	DPD abnormal wave form output terminal (monitor)	DPD	-
63	DPDMUTE	I	DPD TE MUTE control terminal (H: Mute)	DPD	MICOM
64	PLLCTL	I	DPD TE PLL variable input terminal	DPD	SERVO
65	TE1RES	I	DPD TE PLL variable bias resistance	DPD	-
66	DPDGND	P	Power GND input terminal for DPD TE	DPD	-
67	VREFDPD	O	CAP connection terminal for DPD TE center voltage	DPD VC AMP	-
68	RREFDLY	-	Bias resistance connection terminal for Delay Block	Delay Block	-
69	DATA	I	Data input terminal	Serial Interface	MICOM
70	CLOCK	I	Clock input terminal	Serial Interface	MICOM
71	STB	I	Data Enable input terminal	Serial Interface	MICOM
72	OSC		Input terminal for RC value of OSC, for Auto Offset Block	Auto OFSTCTL	-
73	RESET	I	Reset input terminal (L: Reset) for Auto Offset Block	Auto OFSTCTL	MICOM
74	BCAI	I	BCA Filter1	BCA	-
75	BCAO	O	BCA Filter2	BCA	-
76	RFCT	O	RF Ripple Center voltage output terminal for Mirror	MIRROR	DSSP
77	CB2	-	CAP connection terminal of RC value of Bottom Hold, for RFCT generation	MIRROR	-
78	CP2	-	CAP connection terminal of RC value of Peak Hold, for RFCT generation	MIRROR	-
79	RFRP	O	RF Ripple Amp output terminal for Mirror	MIRROR	DSSP
80	RFRPN	I	Input terminal for selecting RFRP Amp gain	MIRROR	-
81	MROFST	I	RF Ripple Offset control terminal for Mirror	MIRROR	-
82	CB1	-	RC connection terminal of RC value of Bottom Hold, for RFRP generation	MIRROR	-
83	CP1	-	RC connection terminal of RC value of Peak Hold, for RFRP generation	MIRROR	-
84	MIRRI	I	Input terminal for MIRR signal generation	MIRROR	-
85	EQVCC	P	Power voltage input signal for RF EQ	RF EQ	-
86	RFEQ0	O	RF EQ output terminal	RF EQ	PLL
87	BCATH	I	BCA Comparating Level control terminal	BCA	DSP
88	EQIN	I	RFAGCO input terminal for RF EQ	RFEQ,RFENV	DSSP
89	RFAGCO	O	RF AGC AMP output terminal	RF AGC	-
90	AGCC	-	CAP connection terminal for time constant of AGC	RF AGC	-
91	AGCI	I	AGC voltage input terminal while in AGC hold	RF AGC	-

Table 1. Pin Description

Pin No.	Pin Name	I/O	Description	Related Block	Related Part
92	EQGND	P	Power GND input terminal for RF EQ	RF EQ	-
93	AGCLEVEL	I	AGC Level control voltage input terminal (3.5 V) while in AGC hold off	RF AGC	-
94	AGCB	-	RC connection terminal for RC value of Bottom Hold, for RF AGC	RF AGC	-
95	AGCP	-	RC connection terminal for RC value of Peak Hold, for RF AGC	RF AGC	-
96	RDPF	-	Bias resistance connection terminal for selecting RF EQ frequency	RF EQ	-
97	EQG	I	RF EQ Boost Gain control voltage input terminal	RF EQ	DSSP
98	EQF	I	RF EQ Peak Frequency control voltage input terminal	RF EQ	DSSP
99	PLL	I	Wide-band PLL compatible RF EQ Peak Frequency Control terminal	RF EQ	DSSP
100	VZOCTL	I	RF EQ zero control terminal	RF EQ	DSSP

## ELECTRICAL CHARACTERISTICS

VCC = 5V, GND = 0V, Vc = 2.5V Ta = 25°C, Vc is center of standard output voltage.

Table 2. Electrical Characteristics

No	Item	Symbol	Input	Measurement Point	Min.	Typ.	Max.	Unit				
<b>CIRCUIT CURRENT</b>												
1	Power Current	ICC	No Signal		150	170	190	mA				
<b>RF SUM &amp; AGC AMP</b>												
2	RF SUM AMP Voltage Gain	Vrfsum1	DVD: 1MHz (A-D) dvd: 300mVpp	RFAGCO (AGCI=1.5V, AGCHOLD=H)	0.8	1	1.2	Vpp				
3		Vrfsum2	CD: 0.2MHz (A-D) cd: 150mVpp									
4	RF SUM AMP Unit Gain Bandwidth	Frsum1	DVD: Frequency Sweep (A-D) dvd: 300mVpp + 120mVdc						20	-	-	MHz
5		Frsum2	CD: Frequency Sweep (A-D) cd: 150mVpp + 120mVdc						20	-	-	MHz
6	AGC Voltage Gain	GAGC1	Each Mode Standard Input AGCIN: 2.5V	RFAGCO (Standard Gain Comparison)	6.0	-	-	dB				
7		GAGC2	Each Mode Standard Input AGCIN: 0.5V						-	-	-6.0	
8	AGC Level	VAGC	Each Mode Standard Input AGCLEVEL = 3.5V	RFAGCO	0.8	1	1.2	Vpp				
<b>ABCD SUM AMP</b>												
9	ABCD SUM AMP Voltage Gain	Vsum1	DVD: 100kHz (A1-D1) dvd: 300mVpp + 150mVdc	ABCD (AGCI =1.5V, AGCHOLD=H)	0.8	1	1.2	Vpp				
10		Vsum2	CD: 100kHz (A1-D1) cd: 150mVpp + 120mVdc									
11	RF SUM AMP -3dB Gain Bandwidth	Fsum1	DVD: Frequency Sweep (A1-D1) dvd: 300mVpp + 150mVdc	ABCD	4	-	-	MHz				
12		Fsum2	CD: Frequency Sweep (A1-D1) cd: 150mVpp + 120mVdc						4	-	-	MHz
<b>RF EQUALIZER</b>												
13	EQ Standard Output	Vrfeq	RFAGCO = 1Vpp	RFEQO	1.9	2.0	2.1	Vpp				
14	EQ Peak Frequency	Fpdvd1	A ~ D: Standard Input Swept Sine	RFEQO	-	6.4	-	MHz				
15		Fpdvd2			-	12.8	-					
16		Fpcd1			-	1.3	-					
17		Fpcd2			-	2.6	-					
18		Fpcd4			-	5.2	-					
19		Fpcd8			-	10.4	-					
20	Group Delay Variation	Δtdvd1	A ~ D: Standard input Swept Sine	RFEQO	-	-	±3	ns				
21		Δtdvd2			-	-	±1.5					
22		Δtcd1			-	-	±20					
23		Δtcd2			-	-	±5					
24		Δtcd4			-	-	±2.5					
25		Δtcd8			-	-	±1.5					

Table 2. Electrical Characteristics (Continued)

No	Item	Symbol	Input	Measurement Point	Min.	Typ.	Max.	Unit
26	Maximum Gain Frequency ( $F_{peak}$ ) Range	Fpeak1	A ~ D: Standard input swept sine, EQG: Vc, EQF: 3.5V	RFEQO	$F_{PEAK} +18$	$F_{PEAK} +20$	$F_{PEAK} +22$	%
27		Fpeak2	A ~ D: Standard input swept sine, EQG: Vc, EQF: 2.5V		$F_{PEAK} -10$	$F_{PEAK} +0$	$F_{PEAK} +10$	
28		Fpeak3	A ~ D: Standard input swept sine, EQG: Vc, EQF: 1.5V		$F_{PEAK} -22$	$F_{PEAK} -20$	$F_{PEAK} -18$	
29	Maximum Gain ( $G_{peak}$ ) Range	Gpeak1	A ~ D: Standard input swept sine, PLL, EQF: Vc, EQG: 1.5V	RFEQO	2.1	3.0	3.8	dB
30		Gpeak2	A ~ D: Standard input swept sine, PLL, EQF: Vc, EQG: 2.5V		-0.9	0.0	0.8	
31		Gpeak3	A ~ D: Standard input swept sine, PLL, EQF: Vc, EQG: 3.5V		-3.8	-3.0	-2.1	
32	Frequency Characteristics Range Correspond to Wide PLL	Fpll1	A ~ D: Standard input swept sine, EQF, EQG: Vc, PLL: 3.75V	RFEQO	$F_{PEAK} +18$	$F_{PEAK} +20$	$F_{PEAK} +22$	%
33		Fpll2	A ~ D: Standard input swept sine, EQF, EQG: Vc, PLL: 2.5V		$F_{PEAK} -10$	$F_{PEAK}$	$F_{PEAK} +10$	
34		Fpll3	A ~ D: Standard input swept sine, EQF, EQG: Vc, PLL: 1.25V		$F_{PEAK} -22$	$F_{PEAK} -20$	$F_{PEAK} -18$	
35	Gain Characteristics Range Correspond to Wide PLL	Gpll	A ~ D: Standard input swept sine, EQF, EQG: Vc, PLL: 3.5V, 2.5V, 1.5V	RFEQO	$G_{PEAK} -0.8$	$G_{PEAK}$	$G_{PEAK} +0.8$	dB
<b>FOCUS ERROR AMP</b>								
36	Voltage Gain	Vfedvd1	(A1,C1) dvd: 1kHz 300mVpp Sine + Vc (B,D) dvd: Vc	FE	0.9	1	1.1	Vpp
37		Vfedvd2	(B1,D1) dvd: 1kHz 300mVpp Sine + Vc (A,C) dvd: Vc					
38		Vfedcd1	(A1,C1) cd: 1kHz 150mVpp Sine + Vc (B,D) cd: Vc					
39		Vfedcd2	(B1,D1) cd: 1kHz 150mVpp Sine + Vc (A,C) cd: Vc					
40	Output Voltage H	Vfeh	B1 = Vc + 2.0Vdc, A1, C1, D1 = Vc	FE	+2.0	+2.1	-	V
41	Output Voltage L	Vfel	B1 = Vc - 2.0Vdc, A1, C1, D1 = Vc		-	-2.1	-2.0	
42	Bandwidth (-3dB Freq.)	Ffedvd	(A1, C1) dvd: 300mVpp Swept sine + Vc (B1, D1) dvd: Vc	FE	50K	60K	70K	Hz
43		Ffedcd	(A1, C1) cd: 150mVpp Swept sine + Vc (B1, D1) cd: Vc					
44	Offset Voltage	Vosfe	(A1 ~ D1) cd, dvd: Vc	FE	-300	0	300	mV
<b>TRACKING ERROR AMP (1 - BEAM)</b>								
45	DPD EQ Standard Gain	Vote1	(A~D) DVD: 281mVpp 200kHz Sine + Vc GAIN_TE1 = 5 dB	DPDMON1 DPDMON2	1.8	2.0	2.2	V
46	Variable Range of DPD Input Amp Gain	Vogte1	(A~D) DVD: 100mVpp 200kHz Sine + Vc GAIN_TE1 = 20 dB	DPDMON1 DPDMON2	1.8	2.0	2.2	V
47		Vogte2	(A~D) DVD: 1000mVpp 200kHz Sine + Vc GAIN_TE1 = 2.5 dB					



Table 2. Electrical Characteristics (Continued)

No	Item	Symbol	Input	Measurement Point	Min.	Typ.	Max.	Unit
48	Output Voltage Correspond to Phase Difference.	Vph1	(A~D) DVD: 250mVpp 21MHz Sine + Vc (A,C)DVD is 45° ahead of (B,D)DVD	TE		-1.0		V
49		Vph2	(A~D) DVD: 250mVpp 21MHz Sine + Vc (A,C)DVD and (B,D)DVD's phase difference = 0°	TE		0		
50		Vph3	(A~D) DVD: 250mVpp 21MHz Sine + Vc (A,C)DVD is 45° behind of (B,D)DVD	TE		+1.0		
51	Variable Range of DPD Frequency Characteristics	Fte1	(A~D) DVD: 250mVpp Sweeping Sine Zero frequency when DPDEQ register is changed	DPDMON1 DPDMON2	0.7	-	2.8	MHz
52		Fte2	(A~D) DVD: 250mVpp Sweeping Sine 1st pole frequency when DPDEQ register is changed		7	-	28	
53		Fte3	(A~D) DVD: 250mVpp Sweeping Sine 2nd pole frequency when DPDEQ register is changed		10	-	40	
54	Depth Control Adjustment Range1 (DVD 1X PLL = 2.5 V Dmax=80 ns)	Tdepc1	(A,B,C,D)DVD: 250mVpp 2.616MHz sine + Vc DELAY_AB = 0 (1/16*Dmax) = 5 ns, DELAY_CD = 7 (1/2*Dmax) = 40 ns	TE	-0.88	-0.73	-0.59	V
55		Tdepc2	(A,B,C,D)DVD: 250mVpp 2.616MHz sine + Vc DELAY_AB = F (Dmax) = 80 ns, DELAY_CD = 7 (1/2*Dmax) = 40 ns		0.67	0.84	1.00	
56		Tdepc3	(A,B,C,D)DVD: 250mVpp 2.616MHz sine + Vc DELAY_AB = 7 (1/2*Dmax) = 40 ns, DELAY_CD = 0 (1/16*Dmax) = 5 ns		0.59	0.73	0.88	
57		Tdepc4	(A,B,C,D)DVD: 250mVpp 2.616MHz sine + Vc DELAY_AB = 7 (1/2*Dmax) = 40 ns, DELAY_CD = F (Dmax) = 80 ns		-1.00	-0.84	-0.67	
58	Depth Control Adjustment Range2 (DVD 1X PLL = 3.75 V Dmax=53.3 ns)	Tdepc5	(A,B,C,D)DVD: 250mVpp 3.924MHz sine + Vc DELAY_AB = 0 (1/16*Dmax) = 3.33 ns, DELAY_CD = 7 (1/2*Dmax) = 26.65 ns	TE	-0.88	-0.73	-0.59	V
59		Tdepc6	(A,B,C,D)DVD: 250mVpp 3.924MHz sine + Vc DELAY_AB = F (Dmax) = 53.3 ns, DELAY_CD = 7 (1/2*Dmax) = 26.65 ns		0.67	0.84	1.00	
60		Tdepc7	(A,B,C,D)DVD: 250mVpp 3.924MHz sine + Vc DELAY_AB = 7 (1/2*Dmax) = 26.65 ns, DELAY_CD = 0 (1/16*Dmax) = 3.33 ns		0.59	0.73	0.88	
61		Tdepc8	(A,B,C,D)DVD: 250mVpp 3.924MHz sine + Vc DELAY_AB = 7 (1/2*Dmax) = 26.65 ns, DELAY_CD = F (Dmax) = 53.3 ns		-1.00	-0.84	-0.67	
62	Depth Control Adjustment Range3 (DVD 1X PLL = 1.25 V Dmax=160 ns)	Tdepc9	(A,B,C,D)DVD: 250mVpp 1.308MHz sine + Vc DELAY_AB = 0 (1/16*Dmax) = 10 ns, DELAY_CD = 7 (1/2*Dmax) = 80 ns	TE	-0.88	-0.73	-0.59	V
63		Tdepc10	(A,B,C,D)DVD: 250mVpp 1.308MHz sine + Vc DELAY_AB = F (Dmax) = 160 ns, DELAY_CD = 7 (1/2*Dmax) = 80 ns		0.67	0.84	1.00	
64		Tdepc11	(A,B,C,D)DVD: 250mVpp 1.308MHz sine + Vc DELAY_AB = 7 (1/2*Dmax) = 80 ns, DELAY_CD = 0 (1/16*Dmax) = 10 ns		0.59	0.73	0.88	
65		Tdepc12	(A,B,C,D)DVD: 250mVpp 1.308MHz sine + Vc DELAY_AB = 7 (1/2*Dmax) = 80 ns, DELAY_CD = F (Dmax) = 160 ns		-1.00	-0.84	-0.67	

Table 2. Electrical Characteristics (Continued)

No	Item	Symbol	Input	Measurement Point	Min.	Typ.	Max.	Unit
66	Depth Control Adjustment Range4 (DVD 2X PLL = 2.5 V Dmax=40 ns)	Tdepc13	(A,B,C,D)DVD: 250mVpp 5.232MHz sine + Vc DELAY_AB = 0 (1/16*Dmax) = 2.5 ns, DELAY_CD = 7 (1/2*Dmax) = 20 ns	TE	-0.88	-0.73	-0.59	V
67		Tdepc14	(A,B,C,D)DVD: 250mVpp 5.232MHz sine + Vc DELAY_AB = F (Dmax) = 40 ns, DELAY_CD = 7 (1/2*Dmax) = 20 ns		0.67	0.84	1.00	
68		Tdepc15	(A,B,C,D)DVD: 250mVpp 5.232MHz sine + Vc DELAY_AB = 7 (1/2*Dmax) = 20 ns, DELAY_CD = 0 (1/16*Dmax) = 2.5 ns		0.59	0.73	0.88	
69		Tdepc16	(A,B,C,D)DVD: 250mVpp 5.232MHz sine + Vc DELAY_AB = 7 (1/2*Dmax) = 20 ns, DELAY_CD = F (Dmax) = 40 ns		-1.00	-0.84	-0.67	
70	Depth Control Adjustment Range5 (DVD 2X PLL = 3.75V Dmax=26.67ns)	Tdepc17	(A,B,C,D)DVD: 250mVpp 7.848MHz sine + Vc DELAY_AB = 0 (1/16*Dmax) = 1.67 ns, DELAY_CD = 7 (1/2*Dmax) = 13.335 ns	TE	-0.88	-0.73	-0.59	V
71		Tdepc18	(A,B,C,D)DVD: 250mVpp 7.848MHz sine + Vc DELAY_AB = F (Dmax) = 26.67 ns, DELAY_CD = 7 (1/2*Dmax) = 13.335 ns		0.67	0.84	1.00	
72		Tdepc19	(A,B,C,D)DVD: 250mVpp 7.848MHz sine + Vc DELAY_AB = 7 (1/2*Dmax) = 13.335 ns, DELAY_CD = 0 (1/16*Dmax) = 1.67 ns		0.59	0.73	0.88	
73		Tdepc20	(A,B,C,D)DVD: 250mVpp 7.848MHz sine + Vc DELAY_AB = 7 (1/2*Dmax) = 13.335 ns, DELAY_CD = F (Dmax) = 26.67 ns		-1.00	-0.84	-0.67	
74	Depth Control Adjustment Range6 (DVD 2X PLL = 1.25 V Dmax=80 ns)	Tdepc21	(A,B,C,D)DVD: 250mVpp 2.616MHz sine + Vc DELAY_AB = 0 (1/16*Dmax) = 5 ns, DELAY_CD = 7 (1/2*Dmax) = 40 ns	TE	-0.88	-0.73	-0.59	V
75		Tdepc22	(A,B,C,D)DVD: 250mVpp 2.616MHz sine + Vc DELAY_AB = F (Dmax) = 80 ns, DELAY_CD = 7 (1/2*Dmax) = 40 ns		0.67	0.84	1.00	
76		Tdepc23	(A,B,C,D)DVD: 250mVpp 2.616MHz sine + Vc DELAY_AB = 7 (1/2*Dmax) = 40 ns, DELAY_CD = 0 (1/16*Dmax) = 5 ns		0.59	0.73	0.88	
77		Tdepc24	(A,B,C,D)DVD: 250mVpp 2.616MHz sine + Vc DELAY_AB = 7 (1/2*Dmax) = 40 ns, DELAY_CD = F (Dmax) = 80 ns		-1.00	-0.84	-0.67	
78	Accuracy according to Delay Step (DVD speed & PLL voltage is variable) Dmax = maximum delay at each mode	Vdlyacc1	(A,B,C,D) DVD: 250mVpp + Vc, Variable frequency according to speed & PLL voltage DELAY_AB = STEP variable DELAY_CD = 7 (1/2*Dmax)	DPDMON1 DPDMON2	83.7	104.6	125.5	mV
79		Vdlyacc2	(A,B,C,D) DVD: 250mVpp + Vc Variable frequency according to speed & PLL voltage DELAY_AB = 7 (1/2*Dmax) DELAY_CD = STEP variable		83.7	104.6	125.5	
80	Tracking Balance Adjustment Range1	Vbalc1	(A,C) DVD: 250 mVpp 2.616MHz sine + Vc (B,D) DVD: 250mVPP 2.616MHz sine +Vc TBAL: Step Variable DVD 1X, PLL = 2.5V	TE	-1.2		1.2	V

Table 2. Electrical Characteristics (Continued)

No	Item	Symbol	Input	Measurement Point	Min.	Typ.	Max.	Unit
81	Tracking Balance Adjustment Range2	Vbalc2	(A,C) DVD: 250 mVpp 3.924MHz sine + Vc (B,D) DVD: 250mVPP 3.924MHz sine +Vc TBAL: Step Variable DVD 1X, PLL = 3.75V	TE	-1.2		1.2	V
82	Tracking Balance Adjustment Range3	Vbalc3	(A,C) DVD: 250 mVpp 1.308MHz sine + Vc (B,D) DVD: 250mVPP 1.308MHz sine +Vc TBAL: Step Variable DVD 1X, PLL = 1.25V	TE	-1.2		1.2	V
83	Tracking Balance Adjustment Range4	Vbalc4	(A,C) DVD: 250 mVpp 5.232MHz sine + Vc (B,D) DVD: 250mVPP 5.232MHz sine +Vc TBAL: Step Variable DVD 2X, PLL = 2.5V	TE	-1.2		1.2	V
84	Tracking Balance Adjustment Range5	Vbalc5	(A,C) DVD: 250 mVpp 7.848MHz sine + Vc (B,D) DVD: 250mVPP 7.848MHz sine +Vc TBAL: Step Variable DVD 2X, PLL = 3.75V	TE	-1.2		1.2	V
85	Tracking Balance Adjustment Range6	Vbalc6	(A,C) DVD: 250 mVpp 2.616MHz sine + Vc (B,D) DVD: 250mVPP 2.616MHz sine +Vc TBAL: Step Variable DVD 2X, PLL = 1.25V	TE	-1.2		1.2	V
86	Tracking Balance Adjustment Accuracy	Vbalacc	(A,C) DVD, (B,D) DVD: standard input according to each speed & PLL voltage TBAL: STEP variable, DVD speed & PLL voltage is variable.	TE			10	mV
87	Phase Comparator Limit1	Vphlim1	(A,C) DVD: Input1, Fin1=2MHz, (B,D) DVD: Input2, PD_LIMIT=90ns	TE	1.296	1.44	1.584	V
88		Vphlim2	(A,C) DVD: Input1, (B,D) DVD: Input2, Fin1 = 2MHz PD_LIMIT = 90ns	TE	-1.584	-1.44	-1.296	
89	Phase Comparator Limit2	Vphlim3	(A,C) DVD: Input1, Fin1=2MHz (B,D) DVD: Input2, PD_LIMIT = 60ns	TE	0.864	0.96	1.056	V
90		Vphlim4	(A,C) DVD: Input1, (B,D) DVD: Input2, Fin1=2MHz PD_LIMIT = 60ns	TE	-1.056	-0.96	-0.864	
91	Phase Comparator Limit3	Vphlim5	(A,C) DVD: Input1, Fin1 = 2MHz (B,D) DVD: Input2, PD_LIMIT = 30ns	TE	0.432	0.48	0.528	V
92		Vphlim6	(A,C) DVD: Input1, (B,D) DVD: Input2, Fin1 = 2MHz PD_LIMIT = 30ns		-0.528	-0.48	-0.432	
93	Abnormal Waveform Detecting Circuit 1 (DVD 1X, PLL = 2.5V)	Tflt1	(A,C) DVD: Input1, Fin1 = 200kHz (B,D) DVD: Input2 Measuring the time from falling edge where only (B,D) DVD exists, to when FAULTO goes "High"	(B,D) DVD FAULTO	-10%	611.6	+10%	ns

Table 2. Electrical Characteristics (Continued)

No	Item	Symbol	Input	Measurement Point	Min.	Typ.	Max.	Unit
94	Abnormal Waveform Detecting Circuit 2 (DVD 1X, PLL = 3.75V)	Tflt2	(A,C) DVD: Input1, Fin1 = 300kHz (B,D) DVD: Input2 Measuring the time from falling edge where only (B,D) DVD exists, to when FAULTO goes 'High'	(B,D) DVD FAULTO	-10%	407.7	+10%	ns
95	Abnormal Waveform Detecting Circuit 3 (DVD 1X, PLL = 1.25V)	Tflt3	(A,C) DVD: Input1, Fin1 = 100kHz (B,D) DVD: Input2 Measuring the time from falling edge where only (B,D) DVD exists, to when FAULTO goes 'High'	(B,D) DVD FAULTO	-10%	1223.2	+10%	ns
96	Abnormal Waveform Detecting Circuit 4 (DVD 2X, PLL = 2.5V)	Tflt4	(A,C) DVD: Input1, Fin1 = 400kHz (B,D) DVD: Input2 Measuring the time from falling edge where only (B,D) DVD exists, to when FAULTO goes 'High'	(B,D) DVD FAULTO	-10%	305.8	+10%	ns
97	Abnormal Waveform Detecting Circuit 5 (DVD 2X, PLL = 3.75V)	Tflt5	(A,C) DVD: Input1, Fin1 = 600kHz (B,D) DVD: Input2 Measuring the time from falling edge where only (B,D) DVD exists, to when FAULTO goes 'High'	(B,D) DVD FAULTO	-10%	203.9	+10%	ns
98	Abnormal Waveform Detecting Circuit 6 (DVD 2X, PLL = 1.25V)	Tflt6	(A,C) DVD: Input1, Fin1 = 200kHz (B,D) DVD: Input2 Measuring the time from falling edge where only (B,D) DVD exists, to when FAULTO goes 'High'	(B,D) DVD FAULTO	-10%	611.6	+10%	ns
99	Offset Voltage	Voste1	DPDMUTE = H	TE	-100	0	100	mV
100	Phase Comparator Input Rise & Fall Time	Tphtt	All comparators must have a rise & fall time of at least 4 ns/V.	-	-	-	4	ns/V
<b>TRACKING ERROR AMP (3 - BEAM)</b>								
101	Voltage Gain	Vte31	E: 1kHz 120mVpp sine +Vc, F: Vc, TBAL=80H	TE	0.9	1	1.1	Vpp
102		Vte32	F: 1kHz 120mVpp sine +Vc, E: Vc, TBAL=80H	TE				
103	Output Voltage H	Vte3h	E: -0.7V, F: Vc	TE	+2.0	+2.1	-	V
104	Output Voltage L	Vte3l	E: +0.7V, F: Vc	TE	-	-2.1	-2.0	
105	Bandwidth (-3dB Freq.)	Fte3	E: 120mVpp swept sine +Vc F: Vc	TE	50K	60K	70K	Hz
106	Tracking Balance Range	Gte31	TBAL = 00H F: 1kHz 120mVpp sine +Vc	TE	+6	-	-	dB
107	Offset Voltage	Gte32	TBAL = FFH F: 1kHz 120mVpp sine +Vc		-	-	-6	dB
108	Offset Voltage	Voste3	E, F: Vc	TE	-300	0	300	mV

Table 2. Electrical Characteristics (Continued)

No	Item	Symbol	Input	Measurement Point	Min.	Typ.	Max.	Unit
109	Tracking Offset Range	Voste31	E, F: Vc, VOFST_TE: 3.5V	TE	400	500	600	mV
110		Voste31	E, F: Vc, VOFST_TE: 1.5V		-600	-500	-400	
<b>MIRROR CIRCUIT</b>								
111	Output Voltage H	Vmirh	RFAGCI: 2.0Vpp sine 10kHz	MIRR	VCC-0.5	-	-	V
112	Output Voltage L	VmirL			-	-	Vee+0.4	
113	Mirr Hold Frequency	Fhold1	RFAGCI: 2.0Vpp f <sub>carrier</sub> = 5MHz 35% AM modulation	MIRR	-	400	600	Hz
114		Fhold2	RFAGCI: 2.0Vpp f <sub>carrier</sub> = 5MHz 70% AM modulation		-	400	600	
115	Bottom Hold Frequency	Fhold1	RFAGCI: 2.0Vpp f <sub>carrier</sub> = 5MHz 35% AM modulation	MIRR	-	550	900	Hz
116		Fhold2	RFAGCI: 2.0Vpp f <sub>carrier</sub> = 5MHz 70% AM modulation		-	550	900	
117	Maximum Operation Frequency	Fmir1	RFAGCI: 2.0Vpp f <sub>carrier</sub> = 5MHz 35% AM modulation	MIRR	150K	-	-	Vpp
118		Fmir2	RFAGCI: 2.0Vpp f <sub>carrier</sub> = 5MHz 70% AM modulation		150K	-	-	
119	Minimum Input Operation Voltage	Vmirin1	RFAGCI: voltage sweep sine 10kHz	MIRR	-	0.1	0.2	Vpp
120	Maximum Input Operation Voltage	Vmirin2			1.8	-	-	
<b>DEFECT CIRCUIT</b>								
121	Output Voltage H	Vdefh	(A1-D1) DVD: 300mVpp + 150mVdc Frequency 1kHz	DFCT	VCC-0.5	-	-	V
122	Output Voltage L	Vdefl			-	-	Vee+0.4	
123	Minimum Operation Frequency	Vdef1	(A1-D1) DVD: 300mVpp + 150mVdc swept sine	DFCT	-	-	1.0	kHz
124	Minimum Operation Frequency	Fdef2			5.0	-	-	
125	Minimum Input Operation Voltage	Vdefin1	ABCDI: 1Vpp pulse 5kHz symmetry 95%	DFCT	-	-	0.5	Vpp
126	Maximum Input Operation Voltage	Vdefin2			1.8	-	-	
<b>FOK DETECT CIRCUIT</b>								
127	Output Voltage H	Vfokh	(A1 ~ D1) DVD: 300mVpp (A1 ~ D1) CD: 150mVpp 1kHz sine wave	FOKB	VCC-0.5	-	-	V
128	Output Voltage L	Vfokl			-	-	Vee+0.4	
129	Threshold Voltage	Vfokth	DC voltage	FOKB	-0.43	-0.39	-0.35	V

Table 2. Electrical Characteristics (Continued)

No	Item	Symbol	Input	Measurement Point	Min.	Typ.	Max.	Unit
130	Maximum Operation Frequency	Ffok	(A1 ~ D1) dvd: 300mVpp (A1 ~ D1) cd: 150mVpp Swept sine	FOKB	45K			Hz
<b>RF ENVELOPE AMP</b>								
131	Output Voltage	Venv	ABCDI: 1Vpp	RFENV	2.45	2.5	2.55	V
132	Envelope Output Frequency Bandwidth	Fenv	30Hz AM modulated signal & 500kHz carrier	RFENV		3K		Hz
<b>ALPC CIRCUIT</b>								
133	Output Voltage H	Valpch	(PD) cd, dvd: +600mV	(LDO) cd, dvd	2.0			V
134	Output Voltage L	valpcl	(PD) cd, dvd: +0mV	(LDO) cd, dvd			-2.0	V
135	Voltage Gain	Galpc	(PD) cd, dvd: +200mVdc + 10mVpp	(LDO) cd, dvd	90	100	110	V/V
136	Output Voltage 1	Valpc	(PD) cd, dvd: +200mV	(LDO) cd,dvd	VD - 0.25	VC	VC + 0.25	V

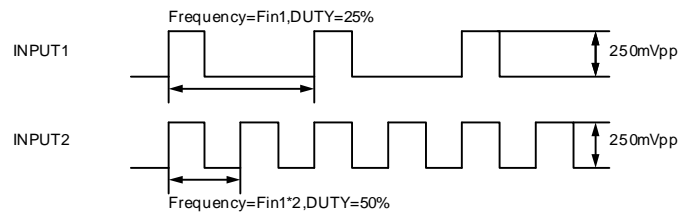

## SERIAL INTERFACE

Serial interface is the part that deals with the following: Disc type, speed, AGC, and the On/Off control of the laser diode.

The timing chart of the serial interface is as follows.

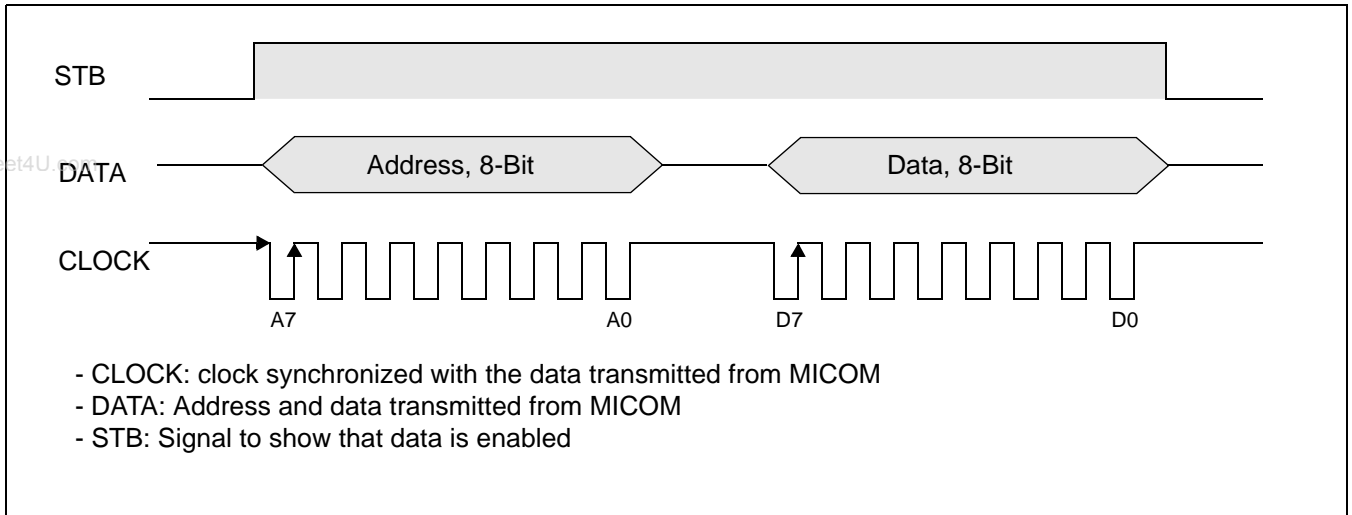

Figure 1. Serial Port Data Transfer Format

◆ Address: 00H

DATA	D7	D6	D5	D4	D3	D2	D1	D0
Function	AGC-HOLD	TESEL	CDRSEL	FLT_CTL	LDONB	SPEED SELECT		
Initial Value	0	0	0	0	0	0	0	0

- D7: Signal for controlling AGC function
  - 1: AGC Off (Hold)
  - 0: AGC On
- D6: Tracking error select
  - 1: TE3
  - 0: DPD
- D5: ALPC, Mux (RF & SUB), FE, ABCD SUM Amp gain select
  - 1: LDOCD, PDCD, (A~D)CD, (A~D)CD1, fe(CD), ABCDSUM(CD) select
  - 0: LDODVD, PDDVD, (A~D)DVD, (A~D)DVDI, fe(DVD), ABCDSUM(DVD) select
- D4: Abnormal wave select
  - 1: FLT HOLD
  - 0: FLT ON
- D3: LASER ON/OFF CONTROL TERMINAL
  - 1: LASER OFF
  - 0: LASER ON
- D2 ~ D0: SPEED SELECT (refer to table on next page)

D2	D1	D0	Mode	Speed
0	X	0	DVD	1X
0	X	1		2X
1	0	0	CD	1X
1	0	1		2X
1	1	0		4X
1	1	1		8X

## ◆ Address 01H: TBAL

Address	Data
01H	TBAL

- Balance adjustment (TBAL) is 0dB when address is 80H (Excluding TBAL DPD Mode).
- When the address is 00H, TBAL is 4dB, and when the address is FFH, TBAL is -4dB (Excluding TBAL DPD Mode).
- TBAL DPD: controls the voltage of the VCPS terminal. Like offset, is at minimum value at 00H, and maximum value at FFH. 2.5V output is produced at 80H.

## ◆ Address 02H: GAIN\_TE3, GAIN\_TEOUT, GAIN\_EQ, GAIN\_TE1IN Adjustment

Data	D7	D6	D5	D4	D3	D2	D1	D0
Function		GAIN_ EQ	DPD_ MUTE	DVCTL_ SEL	ENV_ SEL	GAIN_TE3		
Initial Value		0	0	0	0	0	0	0

- D3: Input ABCDI when 0, EQIN when 1.
- D4: Input DPD Tracking Error ((A+C)-(B+D)) when 0, PIT depth deciding signal ((A+B) - (C+D)) when 1.
- D5: DPD MUTE 'Off' when 0, 'On' when 1
- D6: 0dB when 0, +8dB when 1. (RF SUM block)

## ◆ Address 03H: GAIN\_FE, GAIN\_ABCD Adjustment Select

Data	D7	D6	D5	D4	D3	D2	D1	D0
Function	X	X	GAIN_ABCD			GAIN_FE		
Initial Value	0		0	0	0	0	0	0



- ◆ Address 03H (GAIN\_FE, GAIN\_ABCD), Address 02H (GAIN\_TE3) Gain Select

Data	Gain
0H	0dB (Minimum value)
~	~
7H	8dB (Maximum value)

- ◆ Address 04H ~ 06H: Various Offset Adjustment Data

www.DataSheet4U.com

Address	Data
04H	TE (1,3) Offset
05H	FE Offset
06H	ABCD Sum Offset

- Offset is at minimum value at 00H, and at maximum value at FFH.  
2.5V output is produced at 80H.

- ◆ Address 07H: DELAY\_AB, DELAY\_CD (Delay Control Voltage)

Data	D7	D6	D5	D4	D3	D2	D1	D0
Function	DELAY_AB				DELAY_CD			
Initial Value	0	0	0	0	0	0	0	0

- DELAY\_AB (D4 --D7):Selects amount of delay for pit depth correction delay A,B  
- DELAY\_CD (D0 -- D3): Selects amount of delay for PIT depth correction delay C,D

D7	D6	D5	D4	Delay
0	0	0	0	Dmax *1/16
~	~	~	~	~
1	1	1	1	Dmax

- ◆ Address 08H: DPD PD\_LIMIT, ga\_RFSUM, HOLD\_CTL select

Data	D7	D6	D5	D4	D3	D2	D1	D0
Function	HOLD_CTL	ga_RFSUM			PD_LIMIT			
Initial Value	0	0	0	0	0	0	0	0

- PD\_LIMIT (D0--D3): Output range limit of DPD phase detector

D3	D2	D1	D0	Range Limit
0	0	0	0	160 ns
~	~	~	~	~
1	1	1	1	10 ns

- ga\_RFSUM (D4--D6): Gain select for DPD TE input block

D6	D5	D4	Mode (RFAGCO value compared to Input value)
0	0	0	2.5 dB
~	~	~	~
1	1	1	20 dB

- HOLD\_CTL (D7): Select terminal between the previous abnormal waveform circuit and the new circuit, the latter functions is the default operation.

◆ Address 09H:

Data	D7	D6	D5	D4	D3	D2	D1	D0
Function			ga_PLLDN			ga_PLLDP		
Initial Value	0	0	0	0	0	0	0	0

- ga\_PLLDN (D3--D5): Delay negative sensitivity select following PLL

D5	D4	D3	Mode (Standard input comparison value)
0	0	0	0 dB
~	~	~	~
1	1	1	8 dB

- ga\_PLLDP (D0--D2): Delay positive sensitivity select following PLL

D2	D1	D0	Mode (Standard input comparison value)
0	0	0	0 dB
~	~	~	~
1	1	1	8 dB



PACKAGE DIMENSION

100-TQFP-1414

100-TQFP-1414

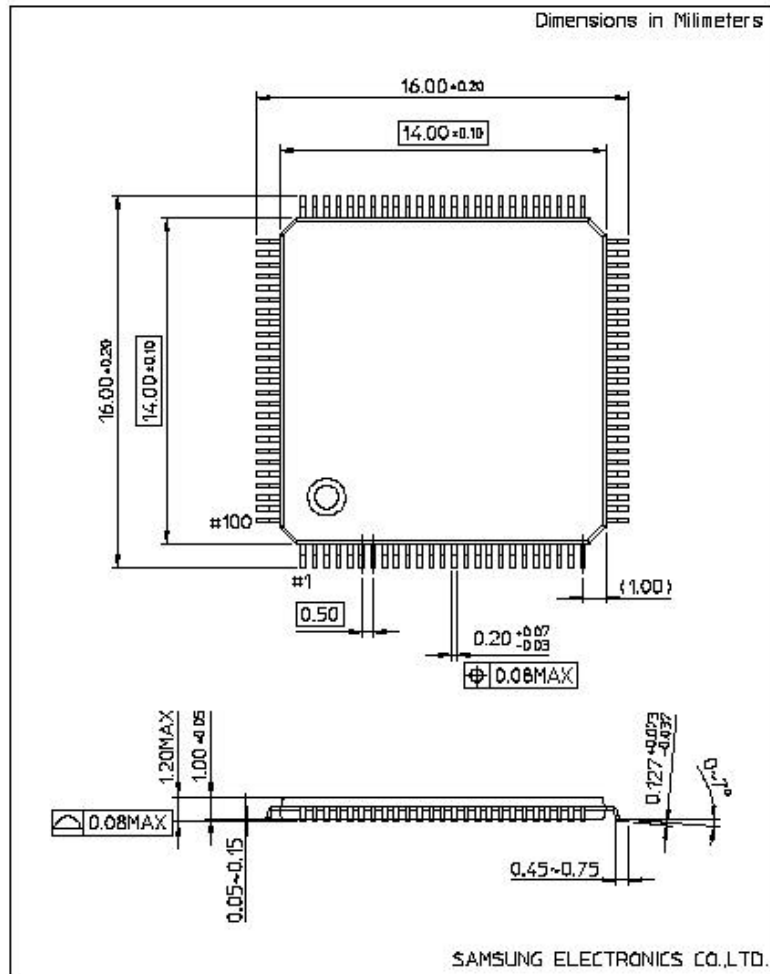

www.DataSheet4U.com