

Telephone Line Interface with Active Line Monitoring

Description

The XE0020 and XE0020C are complete compact telephone interface modules. As with all Xecom DAAs the XE0020 and XE0020C include Ring Detection, Switch-Hook, and Loop Current Holding Circuits. In addition both the XE0020 and XE0020C include two line monitors to insure unobtrusive customer premises operation. The XE0020C also passes the Caller ID signal through to the system host.

Xecom designed the XE0020 and XE0020C for unobtrusive operation in residential applications. Two integral line monitors prevent interference with the residents calls.

Connect Detect verifies line availability before the equipment seizes the line. This will prevent the equipment from interrupting a residents call.

Handset Interrupt signals the system host to drop the call in progress when the resident picks-up an extension phone. This feature permits the resident to interrupt the call in case of emergency.

Caller ID permits the host to identify incoming calls and answer only those from designated call centers.

Together these features give residents priority use of the telephone line without shutting out the equipment.

Features

- * Small Size: 2.0" by 0.5" by 0.4" thick;
- * Supports data transfer at 33,600 bps;
- * FCC Part 68 Compliant;
- * Ring Detection;
- * Continuous Connect Detect Monitor;
- * Handset Interrupt Monitor
- * Single +5 Volt Power Supply;
- * Hookswitch Control
- * Caller ID Signal Path (XE0020C)

Models

XE0020: includes ring detect , hookswitch, Handset Interrupt, Connect Detect, telephone line transformer, loop current holding circuit;

XE0020C: XE0020 features plus Caller ID signal pass through;

Block Diagram

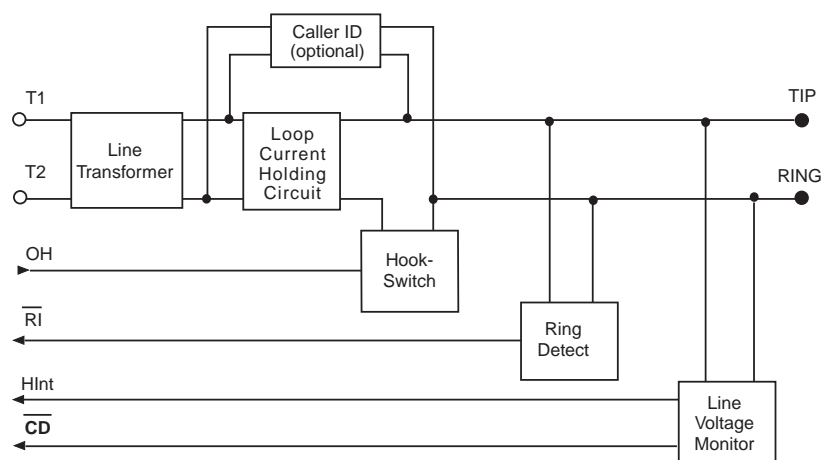

Mechanical Specifications

Dim	Inches		Millimeters	
	Min	Max	Min	Max
A	-	0.400	-	10.16
B	-	0.520	-	13.21
C	-	2.020	-	51.05
D	0.040	0.060	1.02	1.52
E	0.090	0.110	2.29	2.79
F	0.790	0.810	20.07	20.57
G	0.490	0.510	12.45	12.95
H	0.390	0.410	9.91	10.41
I	0.040	0.060	1.02	1.52
J	0.125	0.200	3.18	5.08

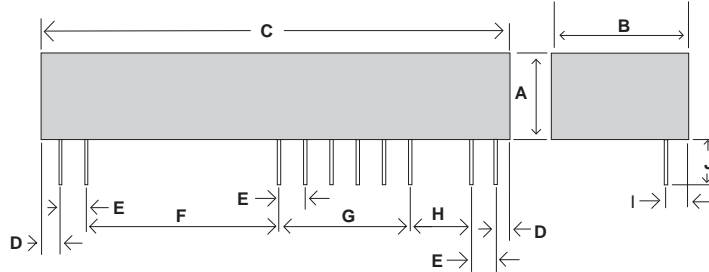

Pin Size: 0.025" by 0.025"
 Recommended hole size: 0.056"
 All pins tin-plated.

XE0020/XE0020C Pin Configuration & Descriptions

bottom view

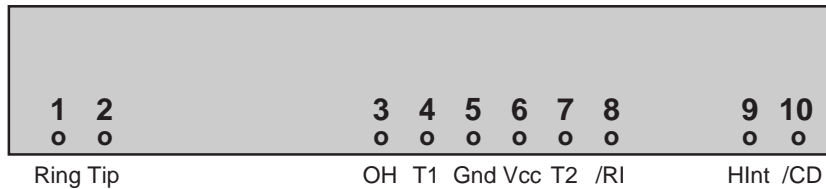

Pin	Name	Description
1	Ring	Ring is one of two signals which form the telephone network connection (RJ11 Pin 4). The XE0020 is not sensitive to the polarity of the battery voltage on the telephone line. Ring has 1500 volts isolation from the rest of the circuitry which must be preserved throughout the system.
2	Tip	Tip provides the second connection to the telephone network (RJ11 Pin 3). Tip has 1500 volts isolation from the rest of the circuitry. This isolation must be preserved throughout the system.
3	OH	Hook-switch relay control an active high input. A high on OH closes the internal relay and connects the equipment to the telephone line.
4	T1	T1 connects directly to the secondary side of the XE0020's internal telephone line transformer.
5	GND	This signal is used as common reference for all of the control signals in the XE0020. Signals on T1 and T2 are not referenced to ground.

Pin Descriptions continued

Pin	Name	Description
6	VCC	VCC provides the + 5 volt power source for the XE0020.
7	T2	T2 connects directly to the secondary side of the XE0020's internal telephone line transformer.
8	/RI	Ring Indicate, output, active low, TTL, RI provides a ring frequency pulse train representation. An external 56K pull-up resistor is required to correctly bias the ring indicate output.
9	HIInt	Handset Interrupt is an active high output from the modem. HIInt goes high for one second if an extension telephone is picked-up while the DAA has control of the line. When the host sees HIInt go high, it should immediately lower OH to disconnect the XE0020 or XE0020C from the telephone line.
10	/CD	Connect Detect, output, active low, TTL. /CD indicates that the XE0020 is connected to the telephone line and the telephone line is not in use.

XE0020/XE0020C Typical Connection Diagram

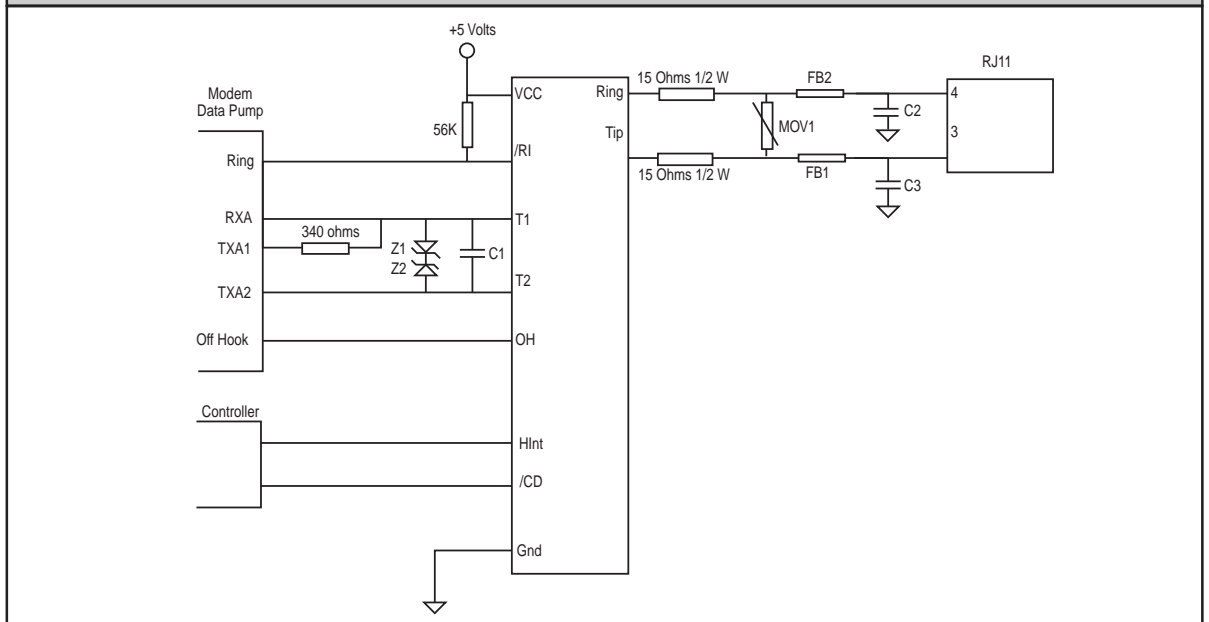

Recommended Parts

Designation	Description
C1	.01 Microfarad
C2,C3	47 pico farad, 3000 volts
Z1, Z2	Zener Diode, 4.3 volts
FB1, FB2	Ferrite Beads (TDK Part Number CCB30-453215B)
MOV1	Minimum Breakover 220 volts (Tecor Electronics Part Number P2600BA70)

Electrical Specification (V_{CC}=+3V ±10%, T_a=0 to 70 deg C)

Parameter	Conditions	Min	Typ	Max	Units
Power Supply Current	Off Hook, 5.0 Volts		10	15	mA
Transmit Insertion loss	600 Ohm Impedance, 1000 Hz	1.7	2.7	3.7	dB
Receive Insertion loss	600 Ohm Impedance, 1000 Hz	1.7	2.7	3.7	dB
Line Impedance	At 1000 Hz, R _m 340 ohms	540	600	660	Ohms
Coupler Match input impedance	Input impedance to T1 & T2	330	340	350	Ohms
Ring Detect Sensitivity (on-hook)	Min. AC voltage between Tip & Ring Type B ringer	38		150	V _{rms}
Ring Detect Peak Current	Ring voltage of 40 V _{rms} applied between Tip & Ring	100			uA
Ring Detect Idle Current	No Ringing Voltage present			10	uA
Ring Indicate Output Voltage	Ring Voltage present on Tip & Ring		0.2	0.5	Volts
Loop Current Switch Control Voltage	ON: (off-hook) OFF: (on-hook)	2.0	3.0 0.2	0.5	Volts Volts
Loop Current Switch Control Current			15	25	mA
Loop Current	Off-Hook current draw from Telephone Line	20		100	mA
Total Harmonic Distortion	At 1800 Hz, -9 dBm signal level	-72	-76		dBm
Connect Detect Threshold			15		Volts
Handset Interrupt Battery Voltage Change At Tip and Ring	40 milliamps loop current	0.5	1.0	1.5	Volts

ABSOLUTE MAXIMUM RATINGS

Storage Temperature	-25°C to +85°C
Operating Temperature Range	0°C to +70°C
Maximum Lead Temperature (soldering 2 seconds per wave)	260°C

Telephone Line Connection Information

When developing a product to be connected to the telephone line, it is necessary to use a circuit described as a Data Access Arrangement (DAA) which is approved by the appropriate governmental agency. In the US, for example, this agency is the Federal Communications Commission (FCC), while in Canada it is Industry Canada. These agencies test and approve the product to ensure that it meets their specifications, thereby protecting the telephone system from damage and protecting the user from high voltage transients (such as lightning strikes) which may come down the telephone line.

The XE0020 has been designed to meet FCC Part 68 requirements for hazardous voltage, surge protection and leakage current. If the system transmits data, or DTMF tones on the telephone line, the user must certify that these transmitted signals meet FCC requirements for maximum transmission levels of out of band energy and billing delay. Full details may be obtained from the FCC under Part 68 of the FCC Rules and Regulations, or in Title 47 of the Code of Federal Regulations, however the basic requirements are as follows:

1. Maximum Transmit Level

For the normal "permissive" (standard) telephone line, equipment which transmits data (such as a modem) must not exceed a transmission level of -9 dBm.

2. Out of Band Energy

Data equipment must not transmit "out of band" energy on the telephone line which exceeds the following limits:

Frequency		Range	Max. Power
200Hz	to	3990Hz	-9 dBm
3990Hz	to	4005Hz	-27 dBm
4005Hz	to	16kHz	-16 dBm
8kHz	to	94kHz	-47 dBm
86kHz	to	270kHz	-46 dBm
270kHz	to	6MHz	-6 dBm

3. DTMF Transmission Level

If the system is capable of DTMF dialing, the maximum DTMF transmission level must be less than 0 dBm averaged over a 3 second interval.

4. Billing Delay

A delay of 2 seconds or greater is required after the time the XE0020 is taken "off hook" and before any information is transmitted. This is required to ensure that billing information may be exchanged between telephone company central offices without interference.

The user of the XE0020 must certify to the FCC that the final system meets the requirements of Part 68 which include the criteria above as well as the high voltage isolation provided by the XE0020. This is generally accomplished through an independent testing lab which test the System and submits the proper paperwork to the FCC for approval. Since the XE0020 already complies with FCC Part 68 rules, this is a relatively simple process.

Terms of Sale

Devices sold by XECOM are covered by the warranty provisions appearing in its Terms of Sale only. XECOM makes no warranty, express, statutory, implied, or by description regarding the information set forth herein, or regarding the freedom of the described devices from patent infringement. XECOM makes no warranty of merchantability or fitness for any purposes. XECOM reserves the right to discontinue production and change specifications and prices at any time and without notice. This product is intended for use in normal commercial applications. Applications requiring extended temperature range, unusual environmental requirements, or high reliability applications, such as military, medical life-support or life-sustaining equipment, are specifically not recommended without additional processing and authorization by XECOM for such application.

Xecom assumes no responsibility for the use of any circuitry other than circuitry embodied in a Xecom product. No other circuits, patents, or licenses are implied.

Life Support Policy

Xecom's products are not authorized for use as Critical Components in Life Support Devices or Systems.

Life Support Devices or Systems are devices or systems which, (a) are intended for surgical implant into the body, or (b) support or sustain life, and whose failure to perform, when properly used in accordance with instructions provided in the labeling, can be reasonably expected to result in significant injury to the user.

A Critical Component is any component of a life support device or system whose failure to perform can be reasonably expected to cause failure of the life support device or system, or to affect its safety or effectiveness.

Copyright, Xecom © 1997

While Xecom, Inc. has made every effort to ensure that the information presented here is accurate, Xecom will not be liable for any damages arising from errors or omission of fact. Xecom reserves the right to modify specifications and/or prices without notice. Product mentioned herein are used for identification purposes only and may be trademarks and/or registered trademarks of their respective companies.



Xecom Incorporated
374 Turquoise Street, Milpitas, CA 95035
Web Site www.xecom.com
Ph:408-945-6640 Fax:408-942-1346 E-Mail info@xecom.com