



# 9N90

**Power MOSFET**

## 900V N-CHANNEL MOSFET

■ DESCRIPTION

The UTC **9N90** uses UTC's advanced proprietary, planar stripe, DMOS technology to provide excellent  $R_{DS(ON)}$ , low gate charge and operation with low gate voltages. This device is suitable for use as a load switch or in PWM applications.

■ FEATURES

- \*  $R_{DS(ON)} = 1.4\Omega @ V_{GS} = 10V$
- \* Ultra Low Gate Charge ( Typical 45 nC )
- \* Low Reverse Transfer Capacitance (  $C_{RSS} =$  Typical 14 pF )
- \* Fast Switching Capability
- \* Avalanche Energy Specified
- \* Improved dv/dt Capability, High Ruggedness

■ SYMBOL

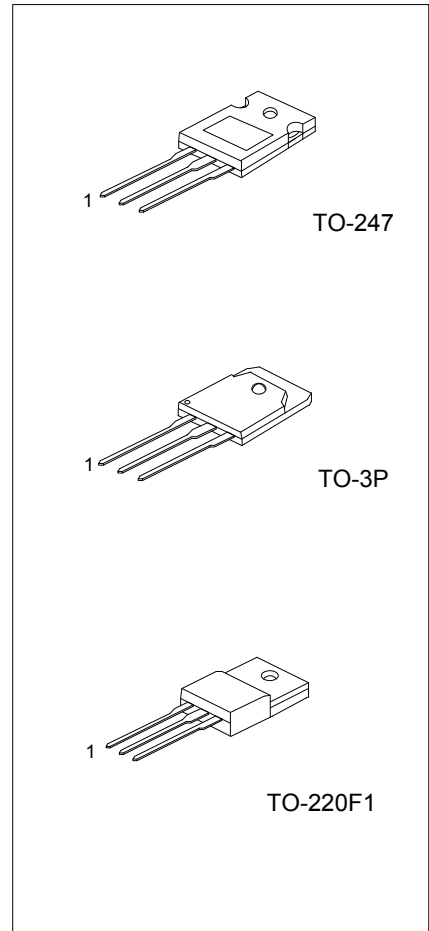
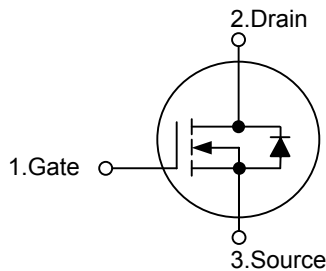

■ ORDERING INFORMATION

Ordering Number		Package	Pin Assignment			Packing
Lead Free	Halogen Free		1	2	3	
9N90L-T47-T	9N90G-T47-T	TO-247	G	D	S	Tube
9N90L-T3P-T	9N90G-T3P-T	TO-3P	G	D	S	Tube
9N90L-TF1-T	9N90G-TF1-T	TO-220F1	G	D	S	Tube

<p>9N90L-T47-T</p> <p>(1)Packing Type (2)Package Type (3)Lead Free</p>	<p>(1) T: Tube (2) T47: TO-247, T3P: TO-3P, TF1: TO-220F1 (3) G: Halogen Free, L: Lead Free</p>
--	---

■ ABSOLUTE MAXIMUM RATING (T<sub>C</sub> = 25°C, unless otherwise specified)

PARAMETER		SYMBOL	RATINGS	UNIT
Drain-Source Voltage		V <sub>DSS</sub>	900	V
Gate-Source Voltage		V <sub>GSS</sub>	±30	V
Continuous Drain Current (T <sub>C</sub> = 25°C)		I <sub>D</sub>	9.0	A
Pulsed Drain Current (Note 2)		I <sub>DM</sub>	36	A
Avalanche Current (Note 2)		I <sub>AR</sub>	9.0	A
Avalanche Energy	Single Pulsed(Note 3)	E <sub>AS</sub>	900	mJ
	Repetitive(Note 2)	E <sub>AR</sub>	28	mJ
Peak Diode Recovery dv/dt (Note 4)		dv/dt	4.0	V/ns
Power Dissipation	TO-247	P <sub>D</sub>	160	W
	TO-3P		240	
	TO-220F1		36	
Linear Derating Factor above T <sub>C</sub> = 25°C	TO-247		1.28	W/°C
	TO-3P		2.22	
	TO-220F1		0.288	W/°C
Junction Temperature		T <sub>J</sub>	150	°C
Storage Temperature		T <sub>STG</sub>	-55 ~ +150	°C

Note: 1. Absolute maximum ratings are those values beyond which the device could be permanently damaged.

Absolute maximum ratings are stress ratings only and functional device operation is not implied.

2. Repetitive Rating : Pulse width limited by maximum junction temperature

3. L = 21mH, I<sub>AS</sub> = 9.0A, V<sub>DD</sub> = 50V, R<sub>G</sub> = 25 Ω, Starting T<sub>J</sub> = 25°C

4. I<sub>SD</sub> ≤ 9.0A, di/dt ≤ 200A/μs, V<sub>DD</sub> ≤ BV<sub>DSS</sub>, Starting T<sub>J</sub> = 25°C

■ THERMAL DATA

PARAMETER		SYMBOL	RATINGS	UNIT
Junction to Ambient	TO-247	θ <sub>JA</sub>	50	°C/W
	TO-3P		40	
	TO-220F1		62.5	
Junction-to-Case	TO-247	θ <sub>JC</sub>	0.78	°C/W
	TO-3P		0.52	
	TO-220F1		3.47	

■ ELECTRICAL CHARACTERISTICS (T<sub>J</sub> = 25°C, unless otherwise specified)

PARAMETER	SYMBOL	TEST CONDITIONS	MIN	TYP	MAX	UNIT
<b>OFF CHARACTERISTICS</b>						
Drain-Source Breakdown Voltage	BV <sub>DSS</sub>	V <sub>GS</sub> = 0 V, I <sub>D</sub> = 250μA	900			V
Drain-Source Leakage Current	I <sub>DSS</sub>	V <sub>DS</sub> = 900 V, V <sub>GS</sub> = 0 V			10	μA
Gate-Body Leakage Current	Forward	I <sub>GSSF</sub>	V <sub>GS</sub> = 30 V, V <sub>DS</sub> = 0 V		100	nA
	Reverse	I <sub>GSSR</sub>	V <sub>GS</sub> = -30 V, V <sub>DS</sub> = 0 V		-100	nA
Breakdown Voltage Temperature Coefficient	ΔBV <sub>DSS</sub> /ΔT <sub>J</sub>	I <sub>D</sub> = 250μA, Referenced to 25°C		0.99		V/°C
<b>ON CHARACTERISTICS</b>						
Gate Threshold Voltage	V <sub>GS(TH)</sub>	V <sub>DS</sub> = V <sub>GS</sub> , I <sub>D</sub> = 250μA	3.0		5.0	V
Static Drain-Source On-Resistance	R <sub>DS(ON)</sub>	V <sub>GS</sub> = 10 V, I <sub>D</sub> = 4.5 A		1.12	1.4	Ω
<b>DYNAMIC PARAMETERS</b>						
Input Capacitance	C <sub>ISS</sub>	V <sub>DS</sub> = 25 V, V <sub>GS</sub> = 0 V, f = 1.0 MHz		2100	2730	pF
Output Capacitance	C <sub>OSS</sub>			175	230	pF
Reverse Transfer Capacitance	C <sub>RSS</sub>			14	18	pF

■ ELECTRICAL CHARACTERISTICS(Cont.)

PARAMETER	SYMBOL	TEST CONDITIONS	MIN	TYP	MAX	UNIT
<b>SWITCHING CHARACTERISTICS</b>						
Turn-On Delay Time	$t_{D(ON)}$	$V_{DD} = 450V, I_D = 11.0 A,$ $R_G = 25\Omega$ (Note 1, 2)		50	110	ns
Turn-On Rise Time	$t_R$			120	250	ns
Turn-Off Delay Time	$t_{D(OFF)}$			100	210	ns
Turn-Off Fall Time	$t_F$			75	160	ns
Total Gate Charge	$Q_G$	$V_{DS} = 720V, I_D = 11.0A,$ $V_{GS} = 10 V$ (Note 1,2)		45	58	nC
Gate-Source Charge	$Q_{GS}$			13		nC
Gate-Drain Charge	$Q_{GD}$			18		nC
<b>DRAIN-SOURCE DIODE CHARACTERISTICS AND MAXIMUM RATINGS</b>						
Drain-Source Diode Forward Voltage	$V_{SD}$	$V_{GS} = 0 V, I_S = 9.0 A$			1.4	V
Maximum Continuous Drain-Source Diode Forward Current	$I_S$				9.0	A
Maximum Pulsed Drain-Source Diode Forward Current	$I_{SM}$				36	A
Reverse Recovery Time	$t_{RR}$	$V_{GS} = 0 V, I_S = 9.0 A,$		550		ns
Reverse Recovery Charge	$Q_{RR}$	$d_{IF} / dt = 100 A/\mu s$ (Note 1)		6.5		$\mu C$

Notes: 1. Pulse Test : Pulse width  $\leq 300\mu s$ , Duty cycle  $\leq 2\%$

2. Essentially independent of operating temperature

■ TEST CIRCUIT

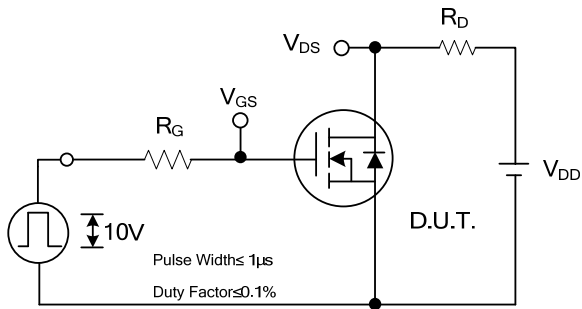

Fig. 2A Switching Test Circuit

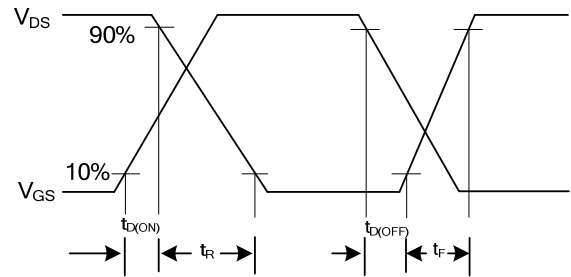

Fig. 2B Switching Waveforms

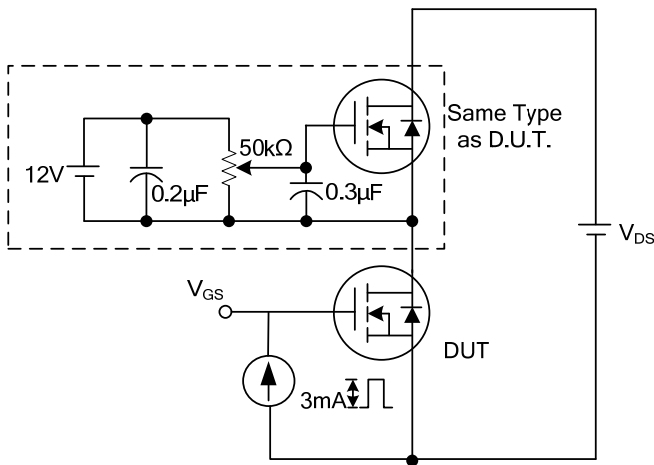

Fig. 3A Gate Charge Test Circuit

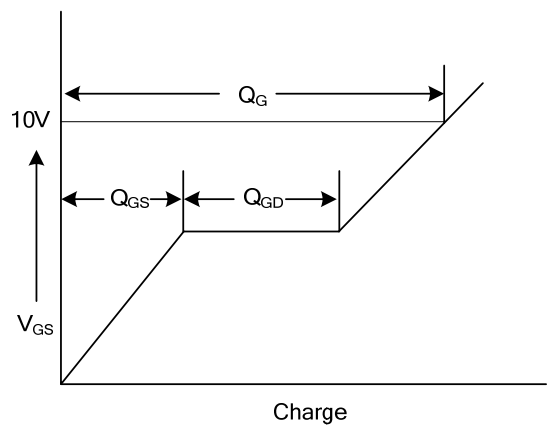

Fig. 3B Gate Charge Waveform

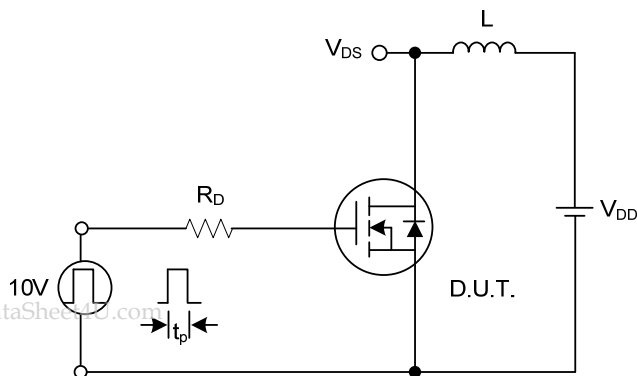

Fig. 4A Unclamped Inductive Switching Test Circuit

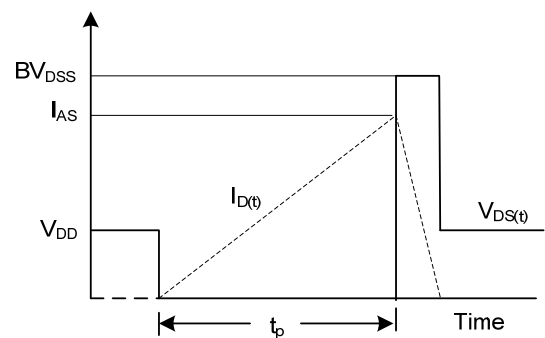

Fig. 4B Unclamped Inductive Switching Waveforms

■ TEST CIRCUIT(Cont.)

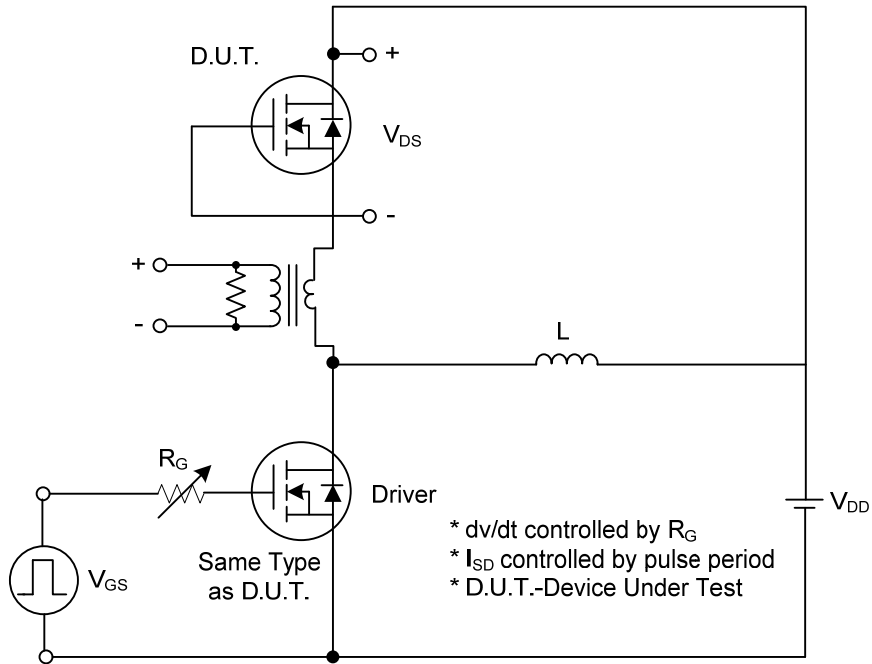
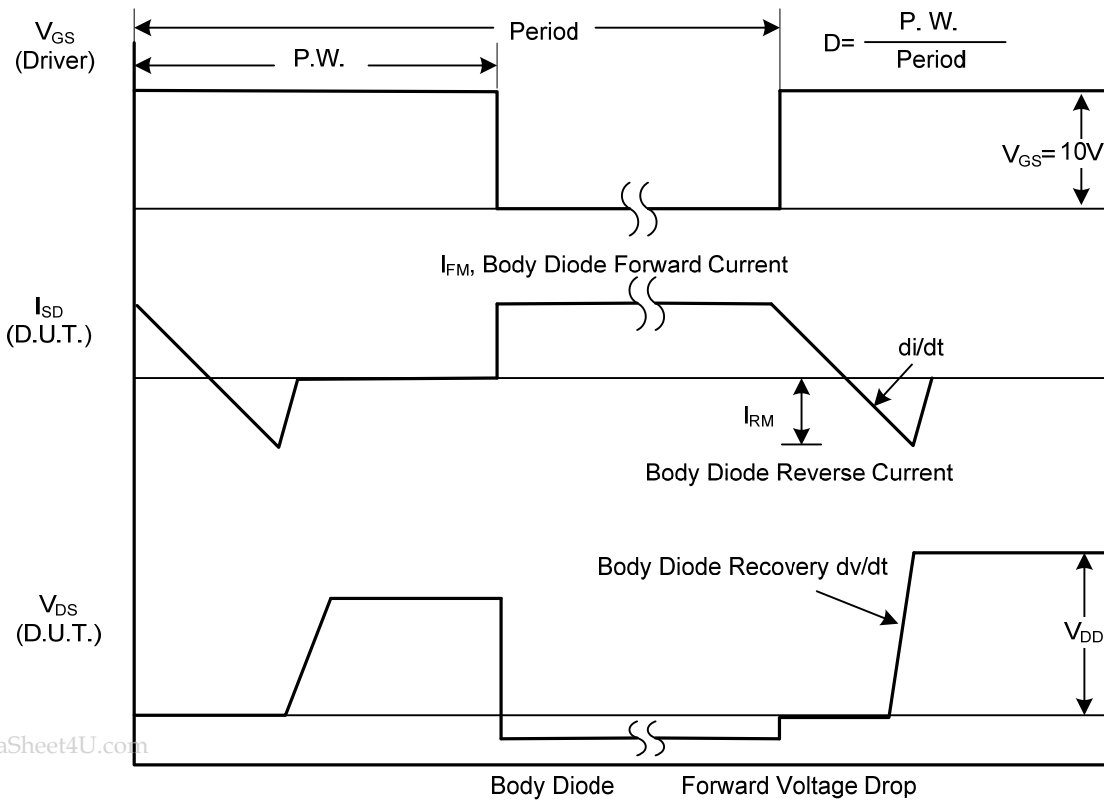
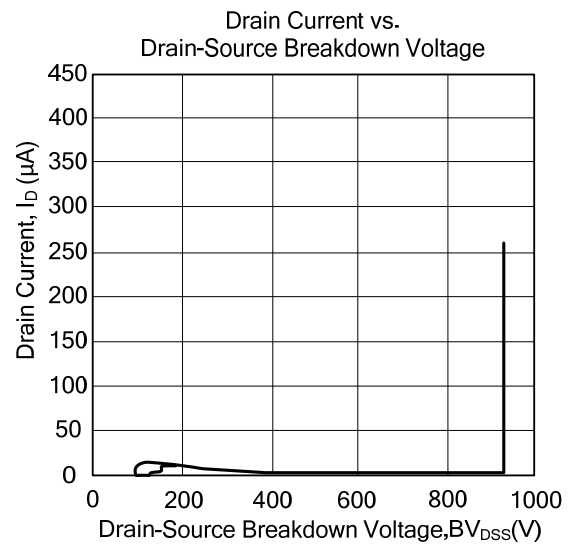
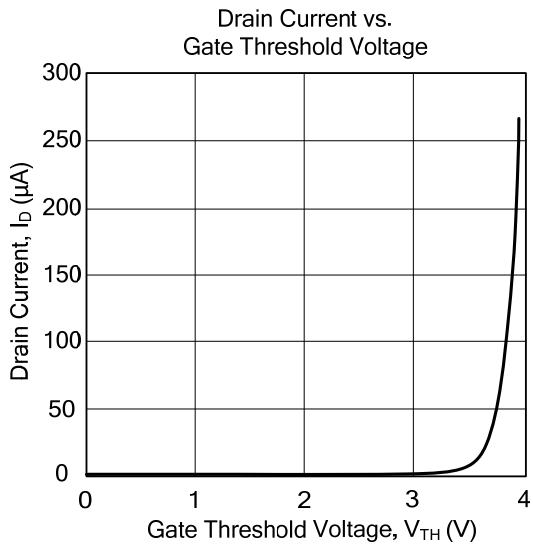
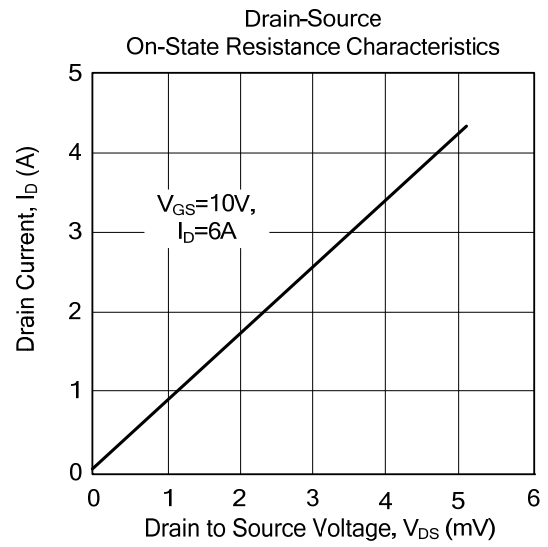
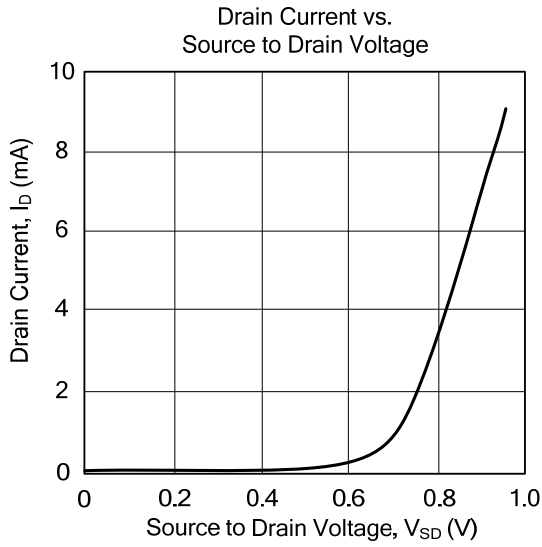

Fig. 1A Peak Diode Recovery dv/dt Test Circuit



www.DataSheet4U.com

■ TYPICAL CHARACTERISTICS



UTC assumes no responsibility for equipment failures that result from using products at values that exceed, even momentarily, rated values (such as maximum ratings, operating condition ranges, or other parameters) listed in products specifications of any and all UTC products described or contained herein. UTC products are not designed for use in life support appliances, devices or systems where malfunction of these products can be reasonably expected to result in personal injury. Reproduction in whole or in part is prohibited without the prior written consent of the copyright owner. The information presented in this document does not form part of any quotation or contract, is believed to be accurate and reliable and may be changed without notice.