

**HC192 - SYNCHRONOUS UP/DOWN DECADE COUNTER**  
**HC193 - SYNCHRONOUS UP/DOWN BINARY COUNTER**

- HIGH SPEED  
 $f_{MAX} = 54 \text{ MHz (TYP.) AT } V_{CC} = 5 \text{ V}$
- LOW POWER DISSIPATION  
 $I_{CC} = 4 \mu\text{A (MAX.) AT } T_A = 25 \text{ }^\circ\text{C}$
- HIGH NOISE IMMUNITY  
 $V_{NIH} = V_{NIL} = 28 \% V_{CC} \text{ (MIN.)}$
- OUTPUT DRIVE CAPABILITY  
 10 LSTTL LOADS
- SYMMETRICAL OUTPUT IMPEDANCE  
 $|I_{OH}| = I_{OL} = 4 \text{ mA (MIN.)}$
- BALANCED PROPAGATION DELAYS  
 $t_{PLH} = t_{PHL}$
- WIDE OPERATING VOLTAGE RANGE  
 $V_{CC} \text{ (OPR)} = 2 \text{ V TO } 6 \text{ V}$
- PIN AND FUNCTION COMPATIBLE WITH  
 54/74LS192-193

**DESCRIPTION**

The M54/74HC192/193 are a high speed CMOS SYNCHRONOUS UP/DOWN DECADE COUNTERS fabricated in silicon gate C<sup>2</sup>MOS technology. They have the same high speed performance of LSTTL combined with true CMOS low power consumption. The counter has two separate clock inputs, an UP COUNT input and a DOWN COUNT input. All outputs of the flip-flop are simultaneously triggered on the low to high transition of either clock while the other input is held high. The direction of counting is determined by which input is clocked. This counter may be preset by entering the desired data on the DATA A, DATA B, DATA C, and DATA D input. When the LOAD input is taken low the data is loaded independently of either clock input. This feature allows the counters to be used as divide-by-n counters by modifying the count length with the preset inputs. In addition the counter can also be cleared. This is accomplished by inputting a high on the CLEAR input. All 4 internal stages are set to low independently of either COUNT input. Both a BORROW and CARRY output are provided to enable cascading of both up and down counting functions. The BORROW output produces a negative going pulse when the counter underflows and the CARRY outputs a pulse when the counter overflows. The counter can be cascaded by connecting the CARRY and BORROW outputs of one device to the COUNT UP and COUNT DOWN inputs, respectively, of the next device. All inputs are equipped with protection circuits against static discharge and transient excess voltage.

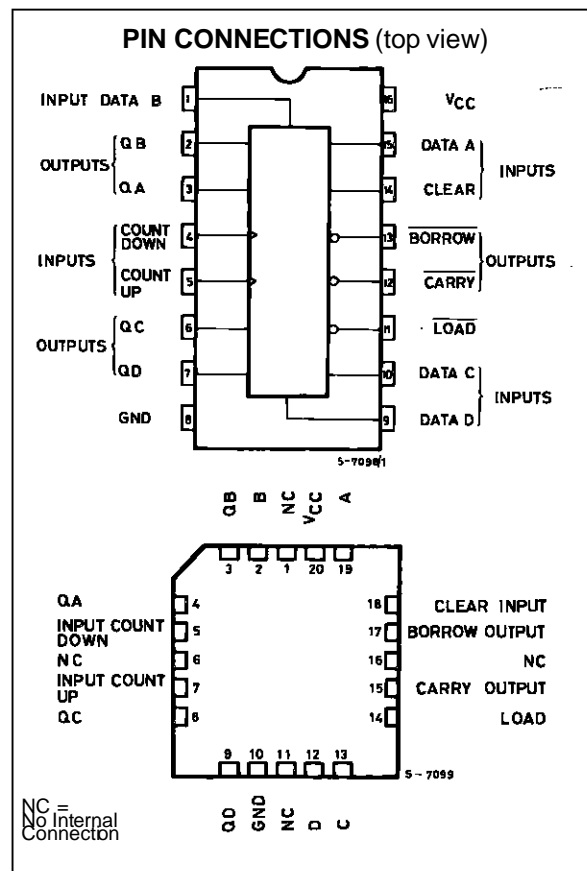
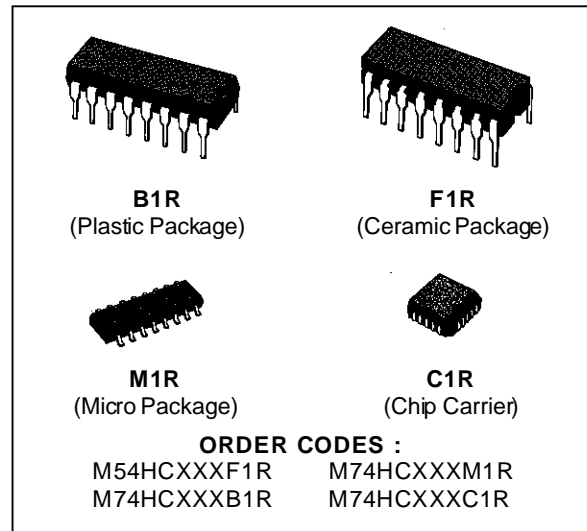

# M54/M74HC192/193

## INPUT AND OUTPUT EQUIVALENT CIRCUIT

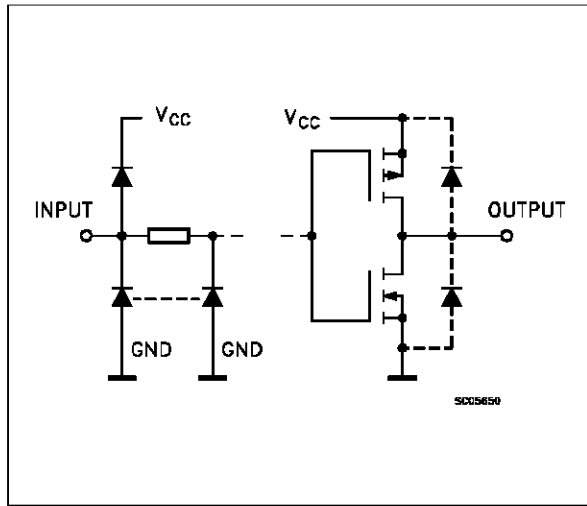

## PIN DESCRIPTION

PIN No	SYMBOL	NAME AND FUNCTION
3, 2, 6, 7	QA to QD	Flip-Flop Outputs
4	CP <sub>D</sub>	Count Down Clock Input
5	CP <sub>U</sub>	Count Up Clock Input
11	$\overline{\text{LOAD}}$	Asynchronous Parallel Load Input (Active LOW)
12	$\overline{\text{CARRY}}$	Count Up (Carry) Output (Active LOW)
13	$\overline{\text{BORROW}}$	Count Down (Borrow) Output (Active LOW)
14	CLEAR	Asynchronous Reset Input (Active HIGH)
15, 1, 10, 9	DA to DD	Data Inputs
8	GND	Ground (0V)
16	V <sub>CC</sub>	Positive Supply Voltage

## IEC LOGIC SYMBOL (HC191)

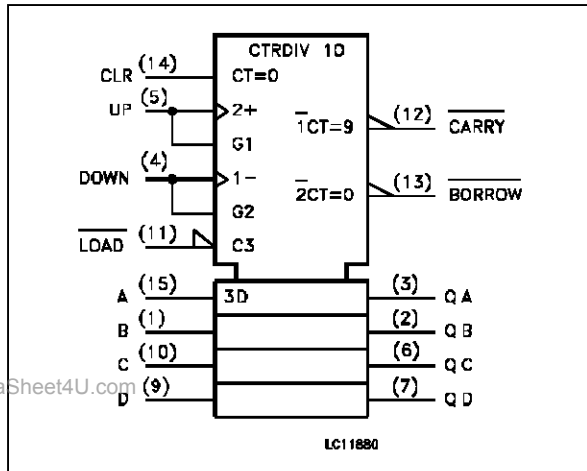

## IEC LOGIC SYMBOL (HC193)

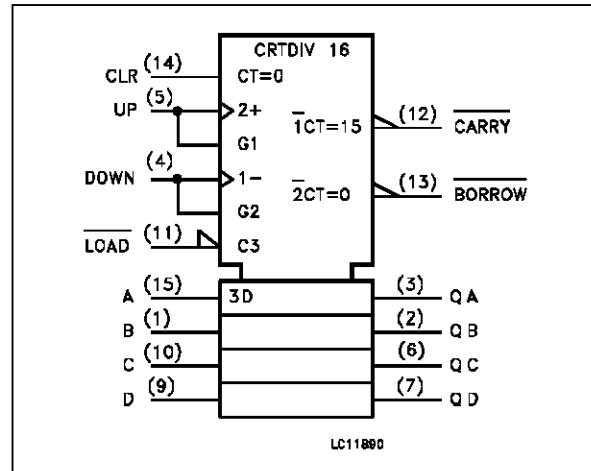

## TRUTH TABLE

COUNT UP	COUNT DOWN	$\overline{\text{LOAD}}$	CLEAR	FUNCTION
	H	H	L	COUNT UP
	H	H	L	NO COUNT
H		H	L	COUNT DOWN
H		H	L	NO COUNT
X	X	L	L	PRESET
X	X	X	H	RESET

X: Don't Care

M54/M74HC192/193

LOGIC DIAGAM (HC192)

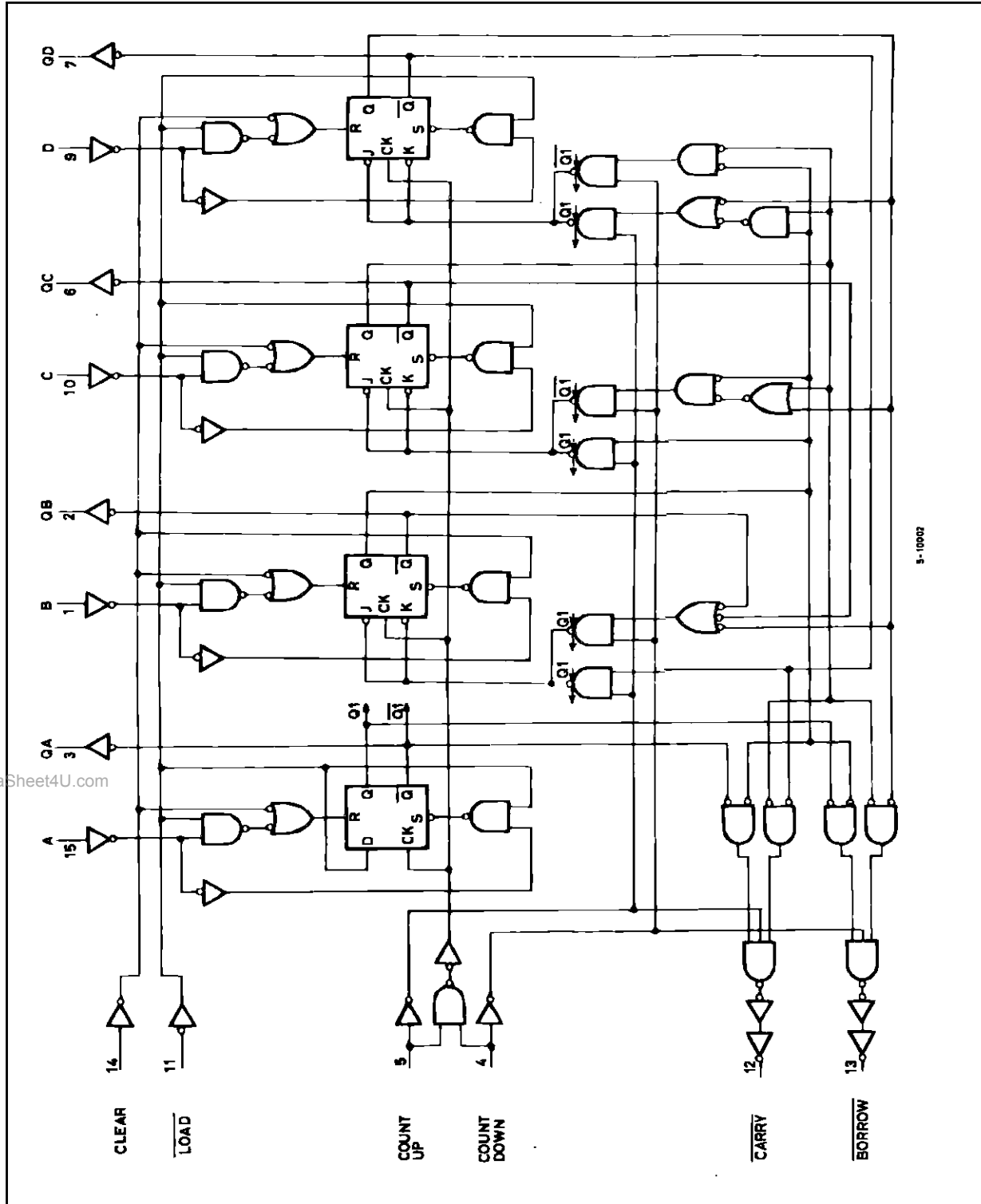

www.DataSheet4U.com

5-10002

# M54/M74HC192/193

## LOGIC DIAGAM (HC193)

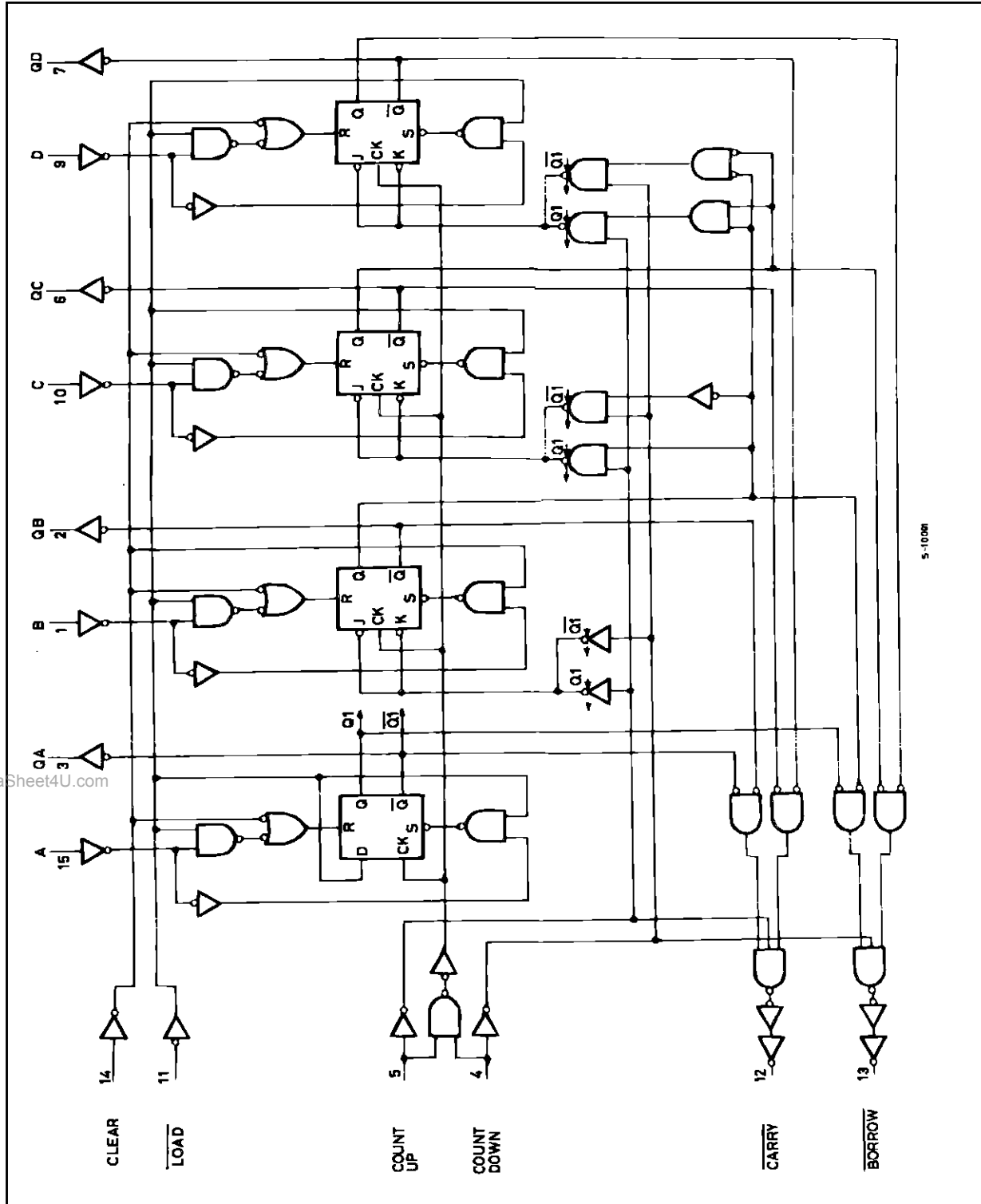

www.DataSheet4U.com

M54/M74HC192/193

TIMING DIAGRAM (HC192)

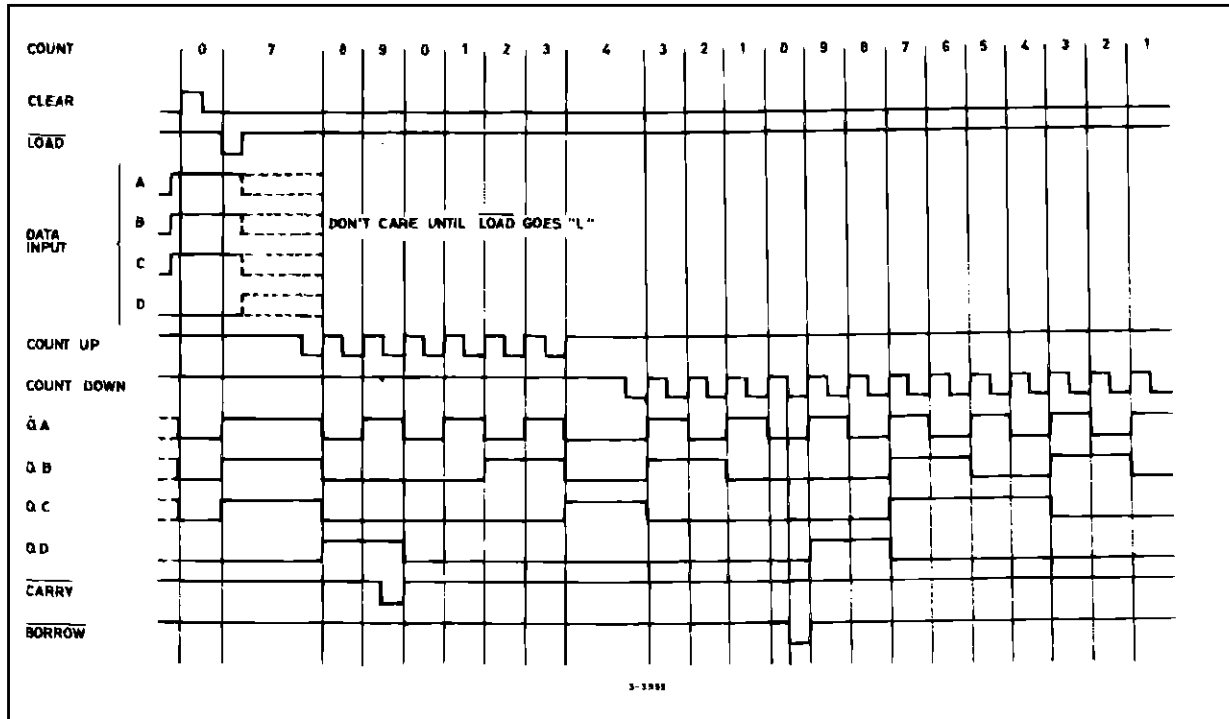

TIMING DIAGRAM (HC193)

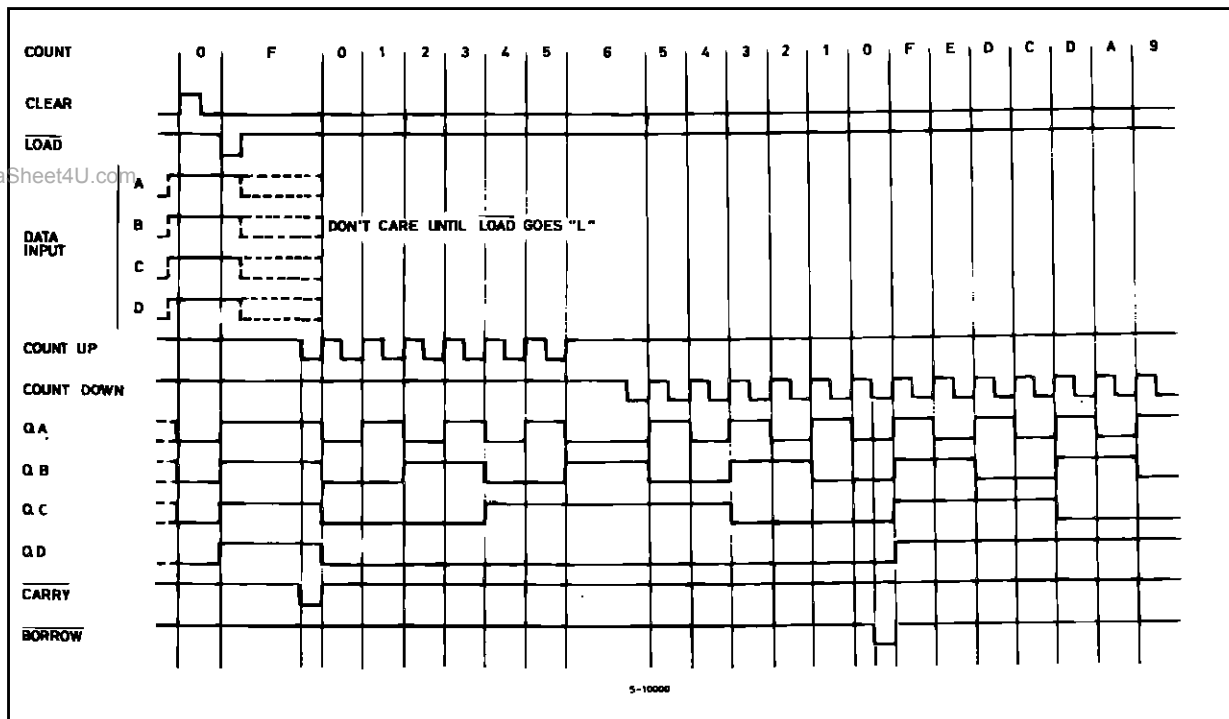

**M54/M74HC192/193****ABSOLUTE MAXIMUM RATINGS**

Symbol	Parameter	Value	Unit
V <sub>CC</sub>	Supply Voltage	-0.5 to +7	V
V <sub>I</sub>	DC Input Voltage	-0.5 to V <sub>CC</sub> + 0.5	V
V <sub>O</sub>	DC Output Voltage	-0.5 to V <sub>CC</sub> + 0.5	V
I <sub>IK</sub>	DC Input Diode Current	± 20	mA
I <sub>OK</sub>	DC Output Diode Current	± 20	mA
I <sub>O</sub>	DC Output Source Sink Current Per Output Pin	± 25	mA
I <sub>CC</sub> or I <sub>GND</sub>	DC V <sub>CC</sub> or Ground Current	± 50	mA
P <sub>D</sub>	Power Dissipation	500 (*)	mW
T <sub>stg</sub>	Storage Temperature	-65 to +150	°C
T <sub>L</sub>	Lead Temperature (10 sec)	300	°C

Absolute Maximum Ratings are those values beyond which damage to the device may occur. Functional operation under these condition is not implied.

(\*) 500 mW: ≡ 65 °C derate to 300 mW by 10mW/°C: 65 °C to 85 °C

**RECOMMENDED OPERATING CONDITIONS**

Symbol	Parameter	Value	Unit	
V <sub>CC</sub>	Supply Voltage	2 to 6	V	
V <sub>I</sub>	Input Voltage	0 to V <sub>CC</sub>	V	
V <sub>O</sub>	Output Voltage	0 to V <sub>CC</sub>	V	
T <sub>op</sub>	Operating Temperature: <b>M54HC Series</b> <b>M74HC Series</b>	-55 to +125 -40 to +85	°C °C	
t <sub>r</sub> , t <sub>f</sub>	Input Rise and Fall Time	V <sub>CC</sub> = 2 V V <sub>CC</sub> = 4.5 V V <sub>CC</sub> = 6 V	0 to 1000 0 to 500 0 to 400	ns

**M54/M74HC192/193****DC SPECIFICATIONS**

Symbol	Parameter	Test Conditions		Value						Unit		
		V <sub>CC</sub> (V)		T <sub>A</sub> = 25 °C 54HC and 74HC			-40 to 85 °C 74HC		-55 to 125 °C 54HC			
				Min.	Typ.	Max.	Min.	Max.	Min.		Max.	
V <sub>IH</sub>	High Level Input Voltage	2.0		1.5			1.5		1.5		V	
		4.5		3.15			3.15		3.15			
		6.0		4.2			4.2		4.2			
V <sub>IL</sub>	Low Level Input Voltage	2.0				0.5		0.5		0.5	V	
		4.5				1.35		1.35		1.35		
		6.0				1.8		1.8		1.8		
V <sub>OH</sub>	High Level Output Voltage	2.0	V <sub>I</sub> = V <sub>IH</sub> or V <sub>IL</sub>	I <sub>O</sub> = -20 μA	1.9	2.0		1.9		1.9	V	
		4.5			4.4	4.5		4.4		4.4		
		6.0			5.9	6.0		5.9		5.9		
		4.5	I <sub>O</sub> = -4.0 mA	4.18	4.31		4.13		4.10			
		6.0		I <sub>O</sub> = -5.2 mA	5.68	5.8		5.63		5.60		
V <sub>OL</sub>	Low Level Output Voltage	2.0	V <sub>I</sub> = V <sub>IH</sub> or V <sub>IL</sub>	I <sub>O</sub> = 20 μA		0.0	0.1		0.1		0.1	V
		4.5				0.0	0.1		0.1		0.1	
		6.0				0.0	0.1		0.1		0.1	
		4.5		I <sub>O</sub> = 4.0 mA		0.17	0.26		0.33		0.40	
		6.0			I <sub>O</sub> = 5.2 mA		0.18	0.26		0.33		
I <sub>I</sub>	Input Leakage Current	6.0	V <sub>I</sub> = V <sub>CC</sub> or GND			±0.1		±1		±1	μA	
I <sub>CC</sub>	Quiescent Supply Current	6.0	V <sub>I</sub> = V <sub>CC</sub> or GND			4		40		80	μA	

**M54/M74HC192/193****AC ELECTRICAL CHARACTERISTICS** ( $C_L = 50 \text{ pF}$ , Input  $t_r = t_f = 6 \text{ ns}$ )

Symbol	Parameter	Test Conditions		Value						Unit	
		V <sub>CC</sub> (V)		T <sub>A</sub> = 25 °C 54HC and 74HC			-40 to 85 °C 74HC		-55 to 125 °C 54HC		
				Min.	Typ.	Max.	Min.	Max.	Min.		Max.
t <sub>TLH</sub> t <sub>THL</sub>	Output Transition Time	2.0			30	75		95		110	ns
		4.5			8	15		19		22	
		6.0			7	13		16		19	
t <sub>PLH</sub> t <sub>PHL</sub>	Propagation Delay Time (UP, DOWN - Q)	2.0			65	190		240		285	ns
		4.5			20	38		48		57	
		6.0			16	32		41		48	
t <sub>PLH</sub> t <sub>PHL</sub>	Propagation Delay Time (UP - CARRY)	2.0			40	130		165		195	ns
		4.5			13	26		33		39	
		6.0			11	22		28		33	
t <sub>PLH</sub> t <sub>PHL</sub>	Propagation Delay Time (DOWN - BORROW)	2.0			40	130		165		195	ns
		4.5			13	26		33		39	
		6.0			11	22		28		33	
t <sub>PLH</sub> t <sub>PHL</sub>	Propagation Delay Time (LOAD - Q)	2.0			85	220		275		330	ns
		4.5			25	44		55		66	
		6.0			20	37		47		56	
t <sub>PLH</sub> t <sub>PHL</sub>	Propagation Delay Time (LOAD - CARRY)	2.0			110	250		315		375	ns
		4.5			30	50		63		75	
		6.0			25	43		54		64	
t <sub>PLH</sub> t <sub>PHL</sub>	Propagation Delay Time (LOAD - BORROW)	2.0			110	250		315		375	ns
		4.5			31	50		63		75	
		6.0			25	43		54		64	
t <sub>PLH</sub> t <sub>PHL</sub>	Propagation Delay Time (DATA - Q)	2.0			80	190		240		285	ns
		4.5			25	38		48		57	
		6.0			20	32		41		48	
t <sub>PLH</sub> t <sub>PHL</sub>	Propagation Delay Time (DATA - CARRY)	2.0			120	250		315		375	ns
		4.5			34	50		63		75	
		6.0			28	43		54		64	
t <sub>PLH</sub> t <sub>PHL</sub>	Propagation Delay Time (DATA - BORROW)	2.0			110	250		315		375	ns
		4.5			30	50		63		75	
		6.0			25	43		54		64	
t <sub>PHL</sub>	Propagation Delay Time (CLEAR - Q)	2.0			100	225		280		340	ns
		4.5			30	45		56		68	
		6.0			25	38		48		58	
t <sub>PLH</sub>	Propagation Delay Time (CLEAR - CARRY)	2.0			120	250		315		375	ns
		4.5			35	50		63		75	
		6.0			29	43		54		64	
t <sub>PHL</sub>	Propagation Delay Time (CLEAR - BORROW)	2.0			120	250		315		375	ns
		4.5			35	50		63		75	
		6.0			29	43		54		64	
f <sub>MAX</sub>	Maximum Clock Frequency	2.0			5	12		4		3.4	MHz
		4.5			25	48		20		17	
		6.0			30	55		24		20	



**M54/M74HC192/193****AC ELECTRICAL CHARACTERISTICS** ( $C_L = 50 \text{ pF}$ , Input  $t_r = t_f = 6 \text{ ns}$ )

Symbol	Parameter	Test Conditions		Value						Unit	
		V <sub>CC</sub> (V)		T <sub>A</sub> = 25 °C 54HC and 74HC			-40 to 85 °C 74HC		-55 to 125 °C 54HC		
				Min.	Typ.	Max.	Min.	Max.	Min.		Max.
t <sub>W(H)</sub> t <sub>W(L)</sub>	Minimum Pulse Width (COUNT UP/DOWN)	2.0			34	100		125		150	ns
		4.5			9	20		25		30	
		6.0			7	17		21		26	
t <sub>W(L)</sub>	Minimum Pulse Width (LOAD)	2.0			34	75		95		110	ns
		4.5			9	15		19		22	
		6.0			7	13		16		19	
t <sub>W(H)</sub>	Minimum Pulse Width (CLEAR)	2.0			40	100		125		150	ns
		4.5			12	20		25		30	
		6.0			10	17		21		26	
t <sub>s</sub>	Minimum Set-up Time (DATA - LOAD)	2.0			30	75		95		110	ns
		4.5			9	15		19		22	
		6.0			7	13		16		19	
t <sub>h</sub>	Minimum Hold Time	2.0				0		0		0	ns
		4.5				0		0		0	
		6.0					0		0		
t <sub>REM</sub>	Minimum Removal Time (LOAD)	2.0			6	50		65		75	ns
		4.5			2	10		13		15	
		6.0			2	9		11		13	
t <sub>REM</sub>	Minimum Removal Time (CLEAR)	2.0			14	50		65		75	ns
		4.5			4	10		13		15	
		6.0			3	9		11		13	
C <sub>IN</sub>	Input Capacitance				5	10		10		10	pF
C <sub>PD</sub> (*)	Power Dissipation Capacitance		for HC192 for HC193		68 67						pF

\*) C<sub>PD</sub> is defined as the value of the IC's internal equivalent capacitance which is calculated from the operating current consumption without load. (Refer to Test Circuit). Average operating current can be obtained by the following equation.  $I_{CC(opr)} = C_{PD} \cdot V_{CC} \cdot f_{IN} + I_{CC}$

M54/M74HC192/193

SWITCHING CHARACTERISTICS TEST WAVEFORM

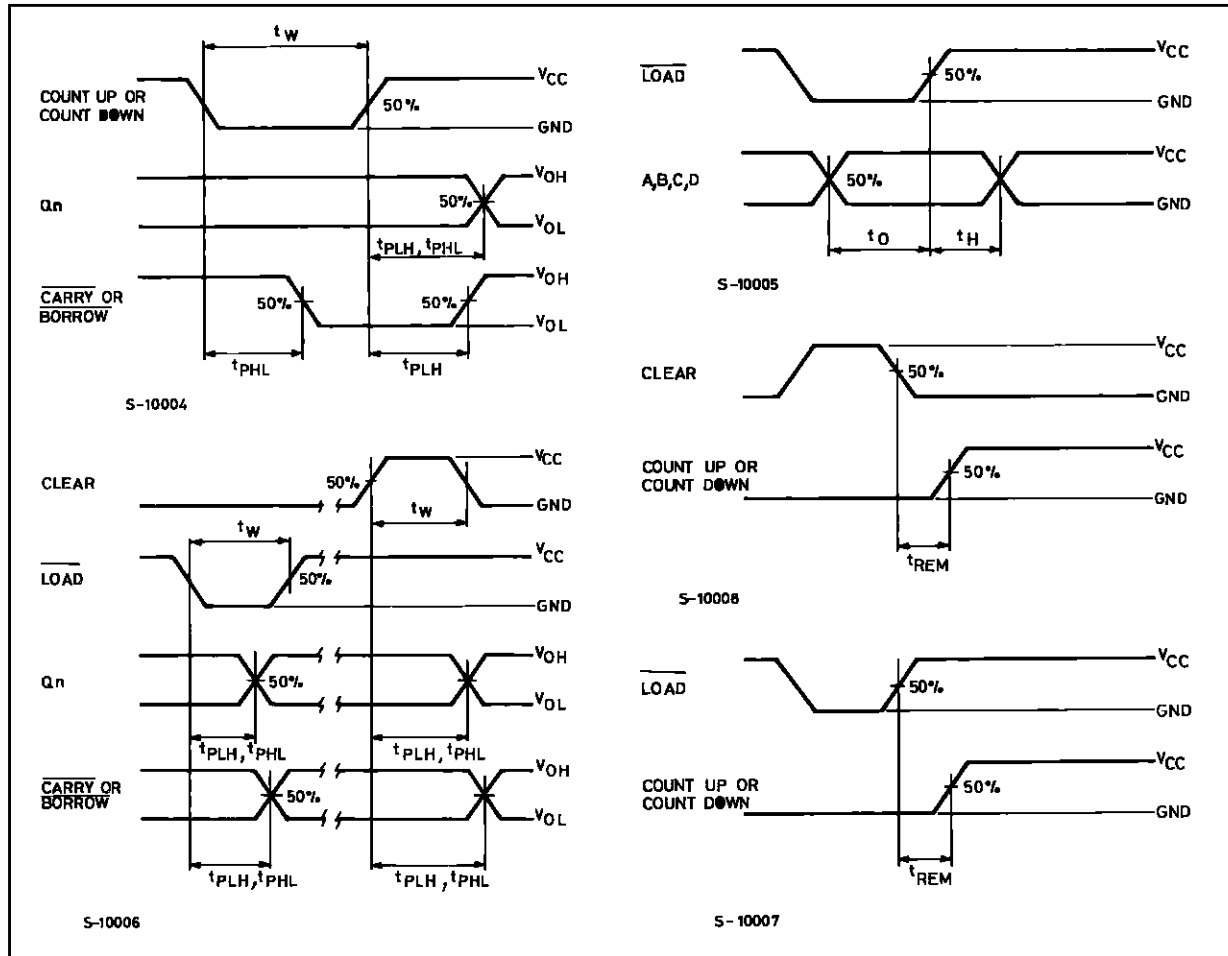

www.DataSheet4U.com

TEST CIRCUIT I<sub>CC</sub> (Opr.)

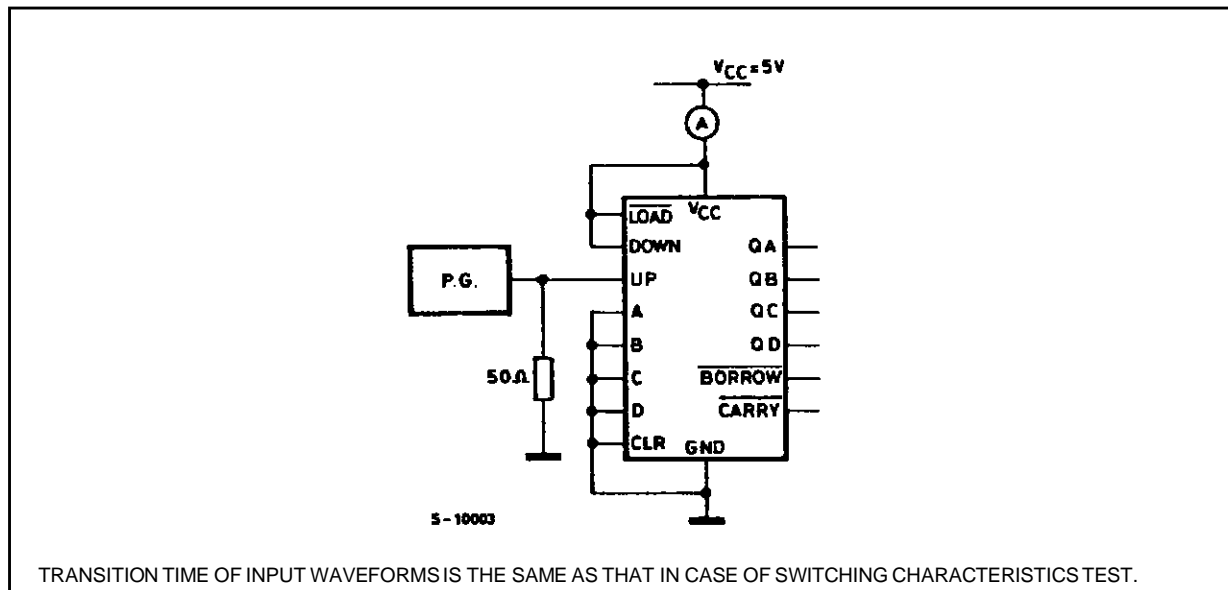

TRANSITION TIME OF INPUT WAVEFORMS IS THE SAME AS THAT IN CASE OF SWITCHING CHARACTERISTICS TEST.

**M54/M74HC192/193****Plastic DIP16 (0.25) MECHANICAL DATA**

DIM.	mm			inch		
	MIN.	TYP.	MAX.	MIN.	TYP.	MAX.
a1	0.51			0.020		
B	0.77		1.65	0.030		0.065
b		0.5			0.020	
b1		0.25			0.010	
D			20			0.787
E		8.5			0.335	
e		2.54			0.100	
e3		17.78			0.700	
F			7.1			0.280
I			5.1			0.201
L		3.3			0.130	
Z			1.27			0.050

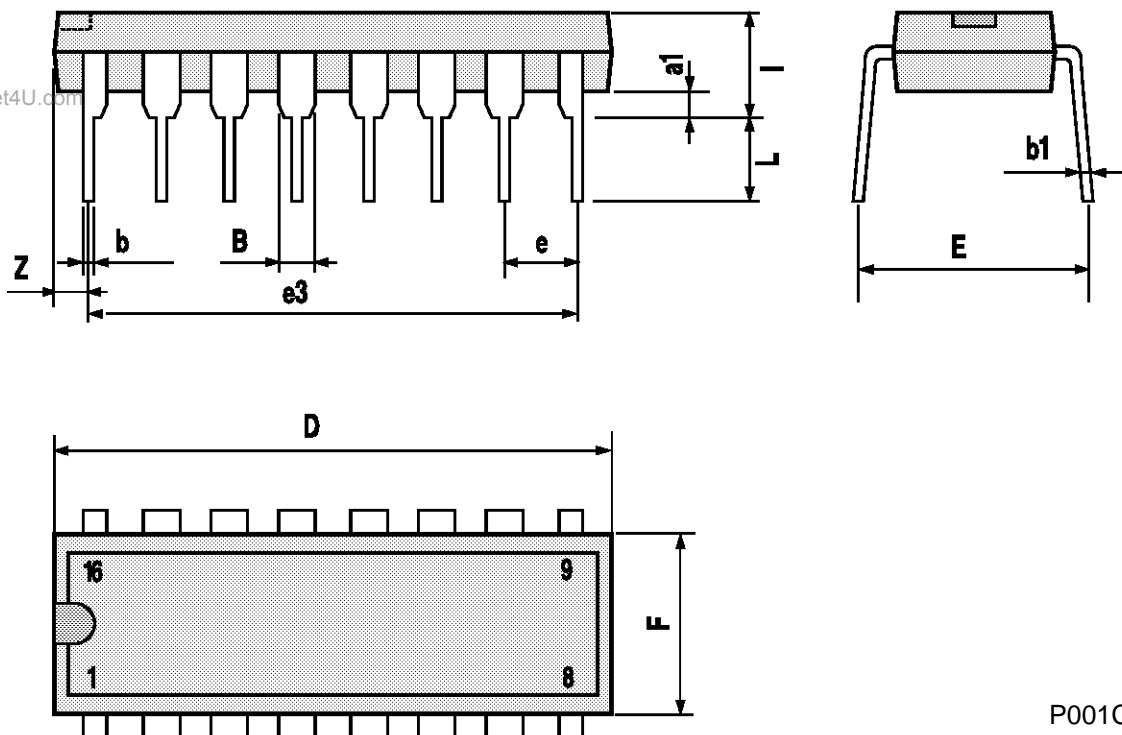

**M54/M74HC192/193****Ceramic DIP16/1 MECHANICAL DATA**

DIM.	mm			inch		
	MIN.	TYP.	MAX.	MIN.	TYP.	MAX.
A			20			0.787
B			7			0.276
D		3.3			0.130	
E	0.38			0.015		
e3		17.78			0.700	
F	2.29		2.79	0.090		0.110
G	0.4		0.55	0.016		0.022
H	1.17		1.52	0.046		0.060
L	0.22		0.31	0.009		0.012
M	0.51		1.27	0.020		0.050
N			10.3			0.406
P	7.8		8.05	0.307		0.317
Q			5.08			0.200

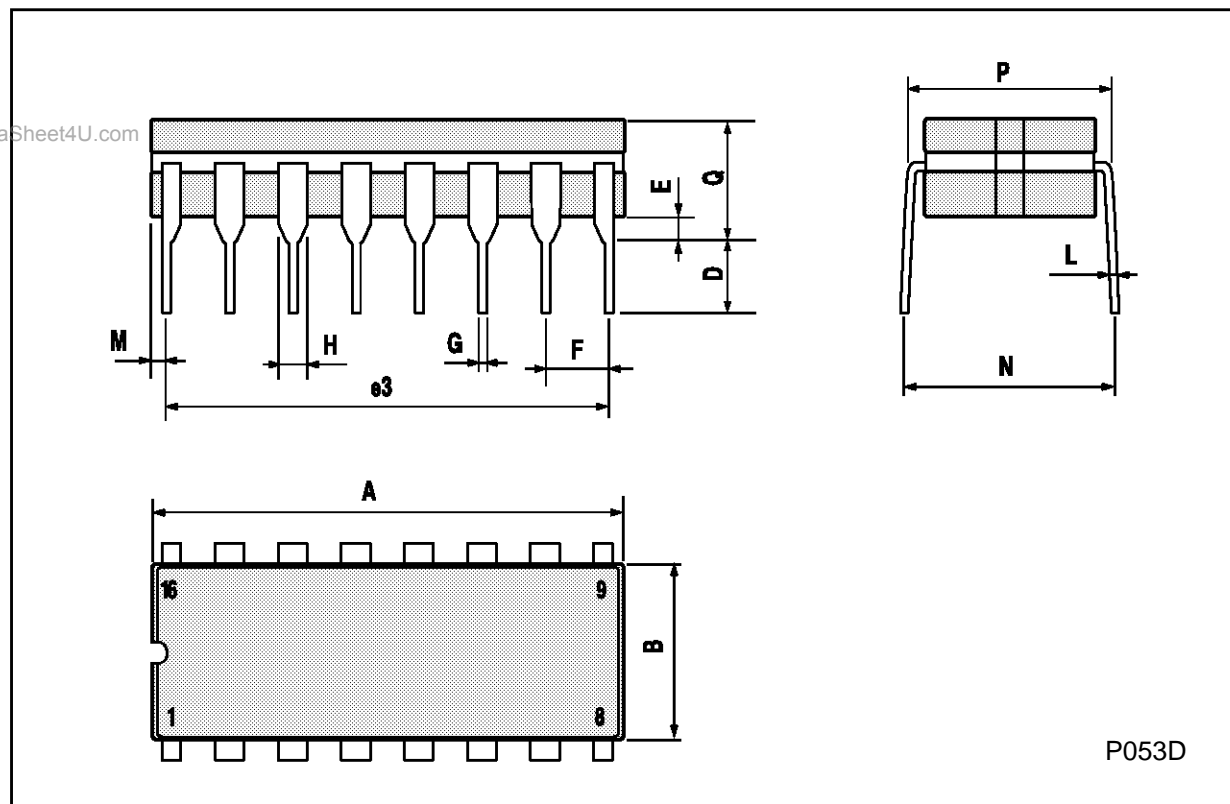

**M54/M74HC192/193****SO16 (Narrow) MECHANICAL DATA**

DIM.	mm			inch		
	MIN.	TYP.	MAX.	MIN.	TYP.	MAX.
A			1.75			0.068
a1	0.1		0.2	0.004		0.007
a2			1.65			0.064
b	0.35		0.46	0.013		0.018
b1	0.19		0.25	0.007		0.010
C		0.5			0.019	
c1	45° (typ.)					
D	9.8		10	0.385		0.393
E	5.8		6.2	0.228		0.244
e		1.27			0.050	
e3		8.89			0.350	
F	3.8		4.0	0.149		0.157
G	4.6		5.3	0.181		0.208
L	0.5		1.27	0.019		0.050
M			0.62			0.024
S	8° (max.)					

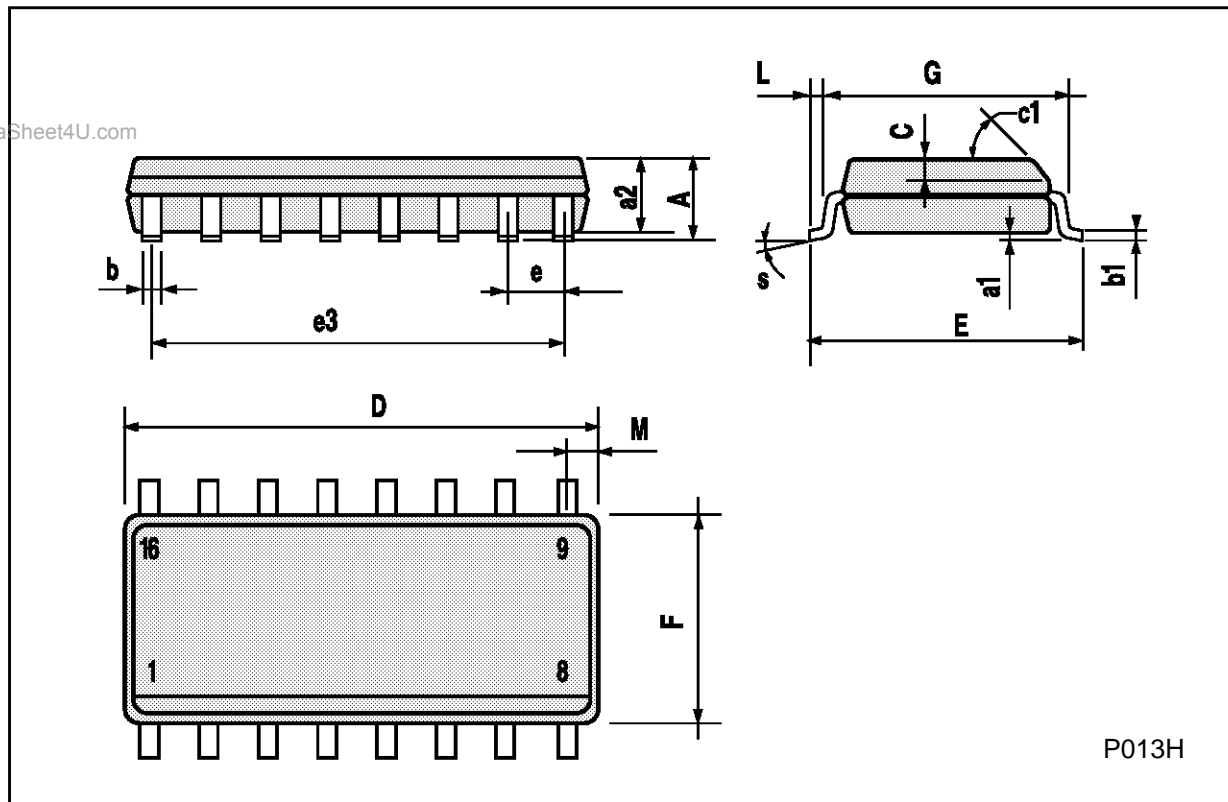

**M54/M74HC192/193****PLCC20 MECHANICAL DATA**

DIM.	mm			inch		
	MIN.	TYP.	MAX.	MIN.	TYP.	MAX.
A	9.78		10.03	0.385		0.395
B	8.89		9.04	0.350		0.356
D	4.2		4.57	0.165		0.180
d1		2.54			0.100	
d2		0.56			0.022	
E	7.37		8.38	0.290		0.330
e		1.27			0.050	
e3		5.08			0.200	
F		0.38			0.015	
G			0.101			0.004
M		1.27			0.050	
M1		1.14			0.045	

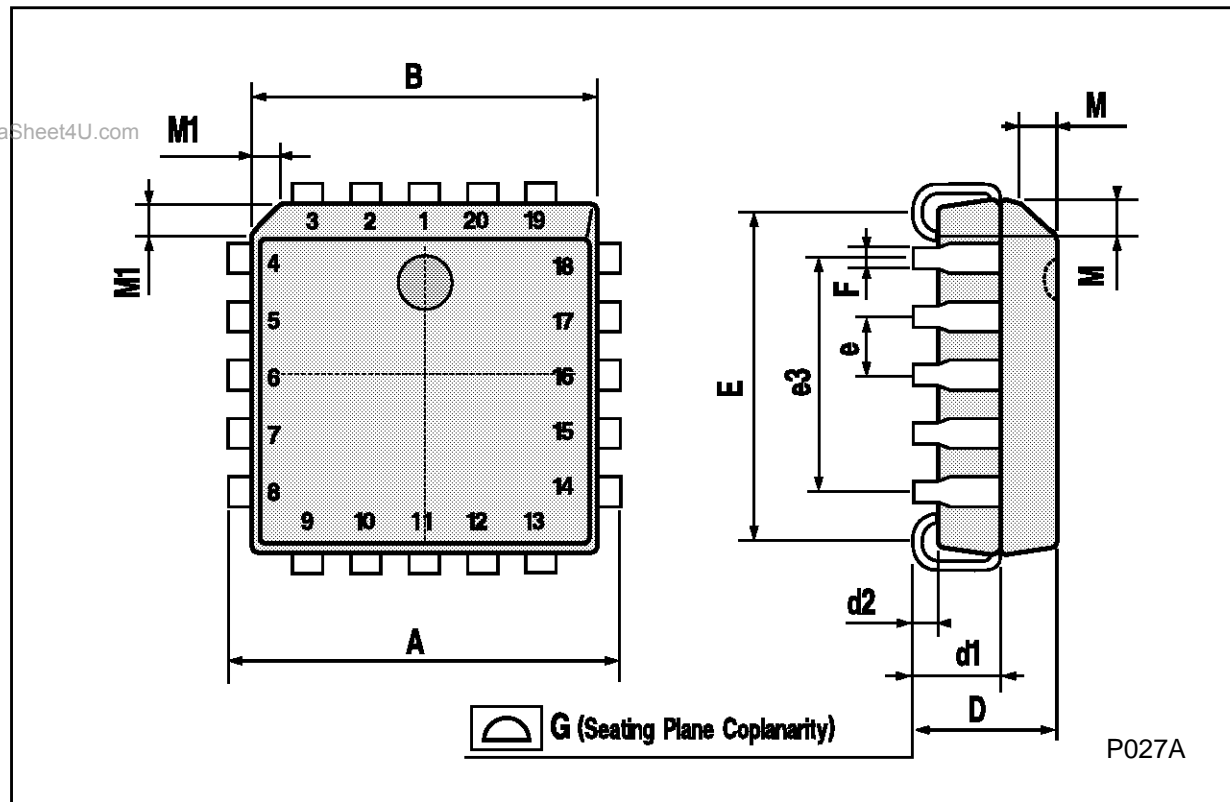

---

**M54/M74HC192/193**

www.DataSheet4U.com

Information furnished is believed to be accurate and reliable. However, SGS-THOMSON Microelectronics assumes no responsibility for the consequences of use of such information nor for any infringement of patents or other rights of third parties which may result from its use. No license is granted by implication or otherwise under any patent or patent rights of SGS-THOMSON Microelectronics. Specifications mentioned in this publication are subject to change without notice. This publication supersedes and replaces all information previously supplied. SGS-THOMSON Microelectronics products are not authorized for use as critical components in life support devices or systems without express written approval of SGS-THOMSON Microelectronics.

© 1994 SGS-THOMSON Microelectronics - All Rights Reserved

SGS-THOMSON Microelectronics GROUP OF COMPANIES  
Australia - Brazil - France - Germany - Hong Kong - Italy - Japan - Korea - Malaysia - Malta - Morocco - The Netherlands -  
Singapore - Spain - Sweden - Switzerland - Taiwan - Thailand - United Kingdom - U.S.A