



T-1(3mm) SOLID STATE LAMPS

LTL-16KR/16KRE RED

LTL-16KG/16KGE GREEN

LTL-16KP/16KPE BRIGHT RED

LTL-16KY/16KYE YELLOW

LTL-16KE/16KEE HIGH EFFICIENCY RED

FEATURES

- LOW POWER CONSUMPTION.
- HIGH EFFICIENCY.
- VERSATILE MOUNTING ON P.C. BOARD OR PANEL.
- CMOS/MOS AND TTL COMPATIBLE.
- LONG LIFE-SOLID STATE RELIABILITY.
- WIDE VIEWING.
- LOW COST.

DESCRIPTION

The Red source color devices are made with Gallium Arsenide Phosphide Red Light Emitting Diode.

The Bright Red source color devices are made with Gallium Phosphide on Gallium Phosphide Red Light Emitting Diode.

The High Efficiency Red source color devices are made with Gallium Arsenide Phosphide on Gallium Phosphide Orange Light Emitting Diode.

The Green source color devices are made with Gallium Phosphide on Gallium Phosphide Green Light Emitting Diode.

The Yellow source color devices are made with Gallium Arsenide Phosphide on Gallium Phosphide Yellow Light Emitting Diode.

DEVICES

PART NO. LTL—	LENS		SOURCE COLOR
	COLOR	DIFFUSION	
16KR 16KRE	Red	Diffused Transparent	Red
16KP 16KPE	Red	Diffused Transparent	Bright Red
16KE 16KEE	Red	Diffused Transparent	Hi. Eff. Red
16KG 16KGE	Green	Diffused Transparent	Green
16KY 16KYE	Yellow	Diffused Transparent	Yellow

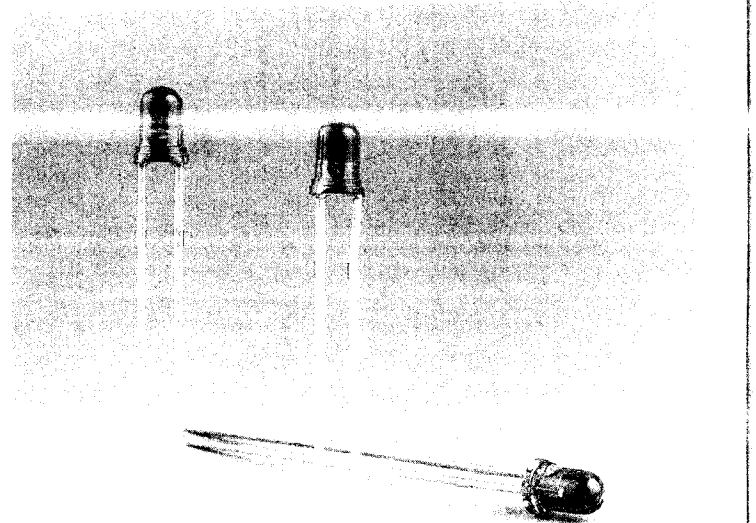

PACKAGE DIMENSIONS

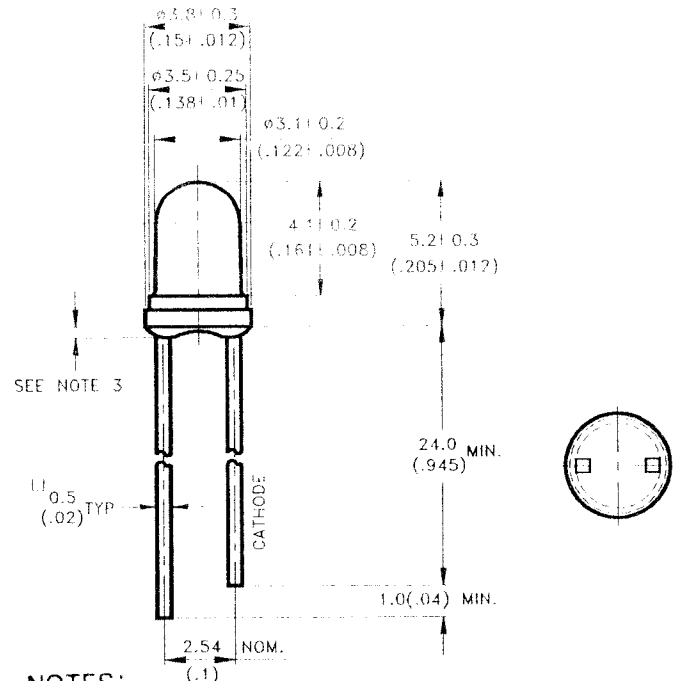

NOTES:

1. All dimensions are in millimeters (inches).
2. Tolerance is $\pm 0.25\text{mm}$ (.010") unless otherwise noted.
3. Protruded resin under flange is 1.0mm (.04") max.
4. Lead spacing is measured where the leads emerge from the package.