

## Piano Keyboard Circuit

### FEATURES

- 12 keys per package
- Loudness proportional to key press velocity
- Sustain input to give loud pedal operation

### DESCRIPTION

The electronic piano chip when used in conjunction with standard divider circuits will make an instrument closely resembling a piano in operation and sound. The chip is arranged so that the loudness of the notes is proportional to the velocity of the keys as in an acoustical instrument. Additionally the notes are arranged to die away at a realistic rate. A sustain input is provided so that the operation of the loud pedal can be emulated.

### PIN CONFIGURATION 40 LEAD DUAL IN LINE

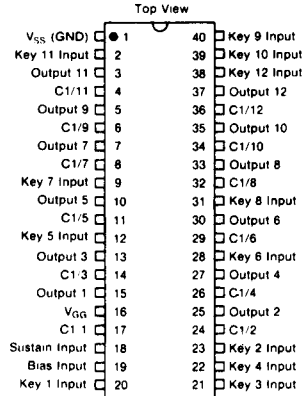

### ELECTRONIC PIANO BLOCK DIAGRAM

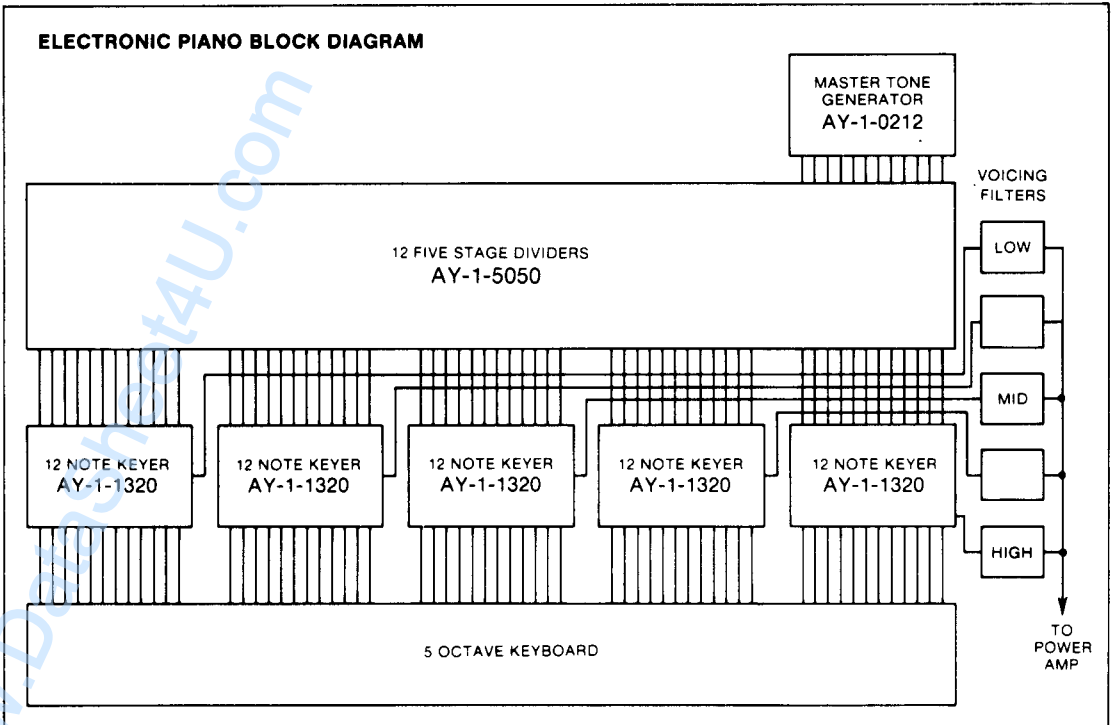

ENTER TAINMENT

## PIN FUNCTIONS

Name	Function
V <sub>SS</sub>	Positive supply
V <sub>GG</sub>	Negative supply (-25 to -29V)
V <sub>BIAS 1</sub>	Bias supply to keying circuit (-27V nominal)
Sustain	When a logic '1' the outputs are damped with a time constant of 180 msec when the key is released. This input simulates the action of the loud pedal in a piano.
Key Inputs (1-12)	These inputs are switched from logic '0' to logic '1' by a break before make change over switch. During the transit the input is held at an intermediate logic level. The transit time determines the initial output level.
C1 (1-12)	The capacitor C1 connected to this pin establishes the key velocity time constant. 0.5 $\mu$ F gives a time constant of 18 msec.
Output (1-12)	This output provides an exponentially decaying DC level proportional to the amplitude of the desired note. The capacitor C2 determines the damper time constant. The resistor R1 together with C2 determines the undamped decay time constant. The DC level is chopped by external frequency dividers to generate the note.

## OPERATION

In the rest condition with the key up capacitor C1 is charged to -12 Volts. When the key is depressed C1 is first disconnected and it starts to discharge through the 39K resistor with a time constant of 18 msec. And the end of the key travel the final voltage on C1 is transferred to the gate of T3 via T2. This causes C2 to be charged to V<sub>C1</sub> + 4 Volts. The faster the key depression the larger the initial voltage on C2 and the louder the note.

The DC voltage on C2 is chopped via R1 and the divider circuit and the resulting square wave is fed to the voicing circuits and amplifiers. C2 slowly discharges through R1 to give the required exponential decay of note amplitude. When the key is released the 50K damping resistor is optionally connected across C2 to damp the notes with a 110 msec time constant.

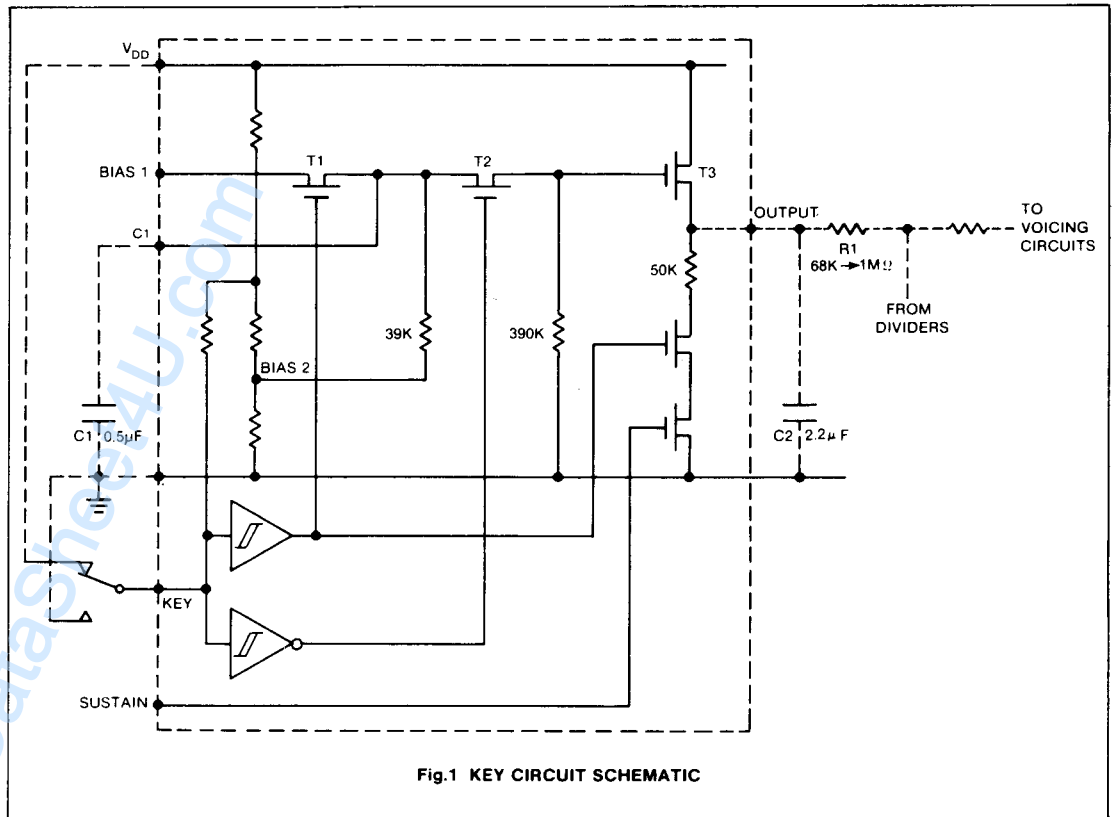

## ELECTRICAL CHARACTERISTICS

## Maximum Ratings\*

Voltage on any pin with respect to  $V_{SS}$  pin ..... +0.3 to -30 Volts  
 Storage Temperature Range ..... -65°C to +150°C  
 Ambient Operating Temperature Range ..... 0°C to +70°C

\*Exceeding these ranges could cause permanent damage. Functional operation of this device at these conditions is not implied—operating ranges are specified below.

## Standard Conditions (unless otherwise noted)

$V_{GG} = -25$  to  $-29$  Volts

$V_{SS} = 0V$

$V_{BIAS1} = V_{GG}$

Operating Temperature ( $T_A$ ) = 0°C to +70°C

Characteristics	Min.	Typ**	Max	Units	Conditions
Key Input Logic '1'	-24	—	-29	V	Key up Key down C1 = 0.5 $\mu$ F (Note 1) (Note 2) See Table 1 C2 = 2.2 $\mu$ F
Key Input Logic '0'	+0.3	—	-1	V	
Key velocity time constant	—	18	—	ms	
Output peak amplitude	—	8	—	V p-p	
Output decay time constant	—	286-2486	—	ms	
Damper time constant	—	110	—	ms	
Dynamic range	—	30	—	dB	
Power Supply Current	—	3	—	mA	
$I_{GG}$	—	3	—	mA	
$I_{BIAS}$	—	3	—	mA	

\*\*Typical values are at +25°C and nominal voltages.

Note 1. The key transit time determines the initial amplitude of the note. The longer the time the softer the note. If the transit time is 18ms the amplitude will be approximately 37% of maximum. Capacitor C1 determines the time constant.

Note 2. This is the amplitude that would be obtained if the key transit time was zero.

Table 1 — TYPICAL COMPONENT VALUES/DECAY TIME  
 C2 = 2.2  $\mu$ F Square wave chopper

Octave	R1 k $\Omega$	R2 k $\Omega$	Decay Time msec
C7-C6# 2093-1108Hz	68	470	286
C6-C5# 1046.4-554.2Hz	120	470	484
C5-C4# 523.2-277.1Hz	220	470	825
C4-C3# 261.6-138.6Hz	330	470	1155
C3-C2# 130.8-69.3Hz	680	470	1980
C2-C1# 65.4-43.6Hz	1000	470	2486

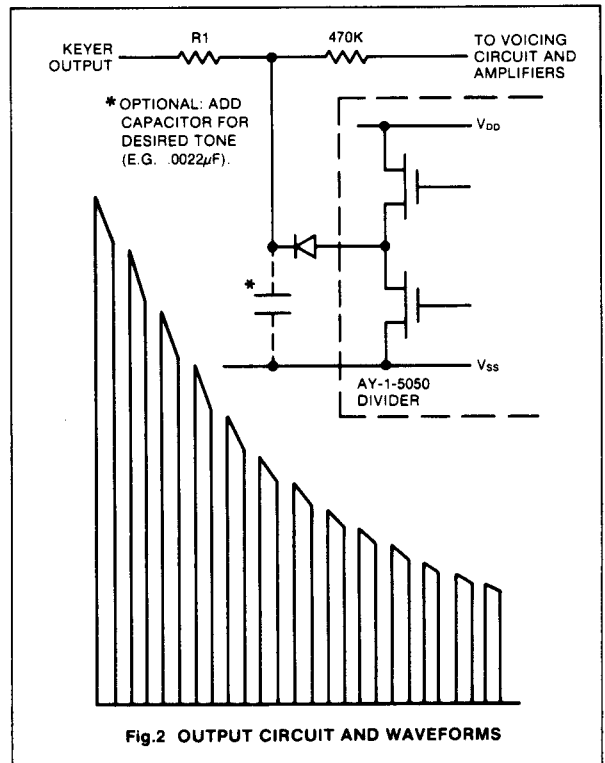

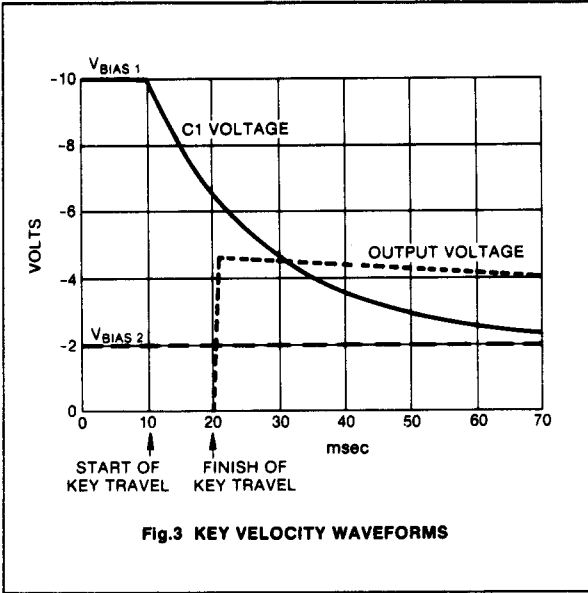

Fig.3 KEY VELOCITY WAVEFORMS

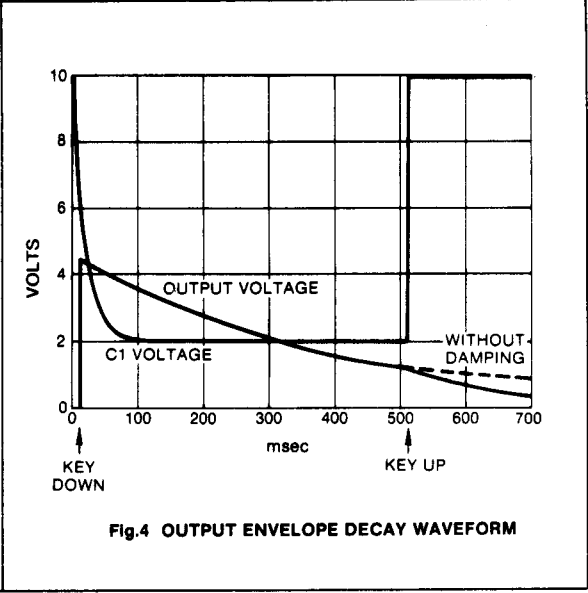

Fig.4 OUTPUT ENVELOPE DECAY WAVEFORM

www.DataSheet4U.com

ENTER-TAINMENT