

Automated Linearization of Sensor Circuits

Tony Ochoa, Xicor, Inc.

Objective

The objective of this application note is to demonstrate 1) the use of the X4023x family of devices to automate linearization techniques in manufacturing of sensor circuits, 2) the use of Xicor’s Windows / LabVIEW driver software for prototyping and manufacturing of these circuits. This application note references examples from the application note AN135 “Sensor Circuits and Digitally Controlled Potentiometers” to demonstrate the concepts herein.

Description

This application note will describe techniques using the X4023x family of devices to automate linearization of a temperature sensor and pressure sensor circuit. A typical X4023x device contains two voltage monitors, two digitally-controlled potentiometers, voltage good logic outputs, general purpose EEPROM, and a fault detection register. In addition, programming of the device is achieved via 2-wire bus. This application note will provide examples of how these functions can be used for zero offset and full scale adjustments and how to monitor critical voltages for automated calibration in manufacturing. Table 1 provides a summary of the functions available in the X4023x family. Figure 1 depicts a conceptual block diagram of areas where the X4023x can be used in sensor signal conditioning circuits. Further details are provided for specific examples below.

Table 1: X4023X Family Selector Guide

X=	256 Tap	100 Tap	64 Tap
1		1	1
3	1		
5	1		
7	1		1
9	1	1	

PRTD Signal Conditioning Circuit

Figure 2A depicts a simplified example of a PRTD (platinum resistance temperature detector) is a bridge circuit whose output is amplified by a high performance instrumentation amplifier (IA). Amongst the problems associated with this traditional approach is the lack of variability to account for sensor variations, lack of a linearization scheme, and the high cost of the instrumentation amplifier.

The PRTD temperature response consist of resistance variation of the order of only tenths of ohms/C. Hence strict attention must be paid to the effects of the transducer lead wire resistance. Table 2 lists the design consideration required.

Table 2: Design Considerations of PRTD Circuits
(Source: Xicor Application Note 135).

Design Consideration	Notes
Magnitude of the excitation current must also be severely limited	Excessive I^2R PRTD power dissipation will cause unacceptable large self-heating measurement errors
Low excitation currents and small resistance changes means PTRTD signal will be in the order of tens of $\mu V/C$	Requirement of stable high gain DC amplification in the signal chain
PRTD temperature coefficient is only ‘reasonably’ invariant with temperature and, as a result, the PRTD’s response is significantly non-linear	Accurate measurement of temperature over wide range depends on the provision for linearization of the PRTD signal

Figure 2B provides a solution to these design considerations using Xicor’s X4023x. The results provide a precision thermometer with an output span and span that is tunable using two digitally-controlled potentiometers. Current excitation of the PRTD is sourced by the 2.5V voltage reference VR1 via R1. The DCP1 (digitally controlled potentiometer of the X4023x) provides for

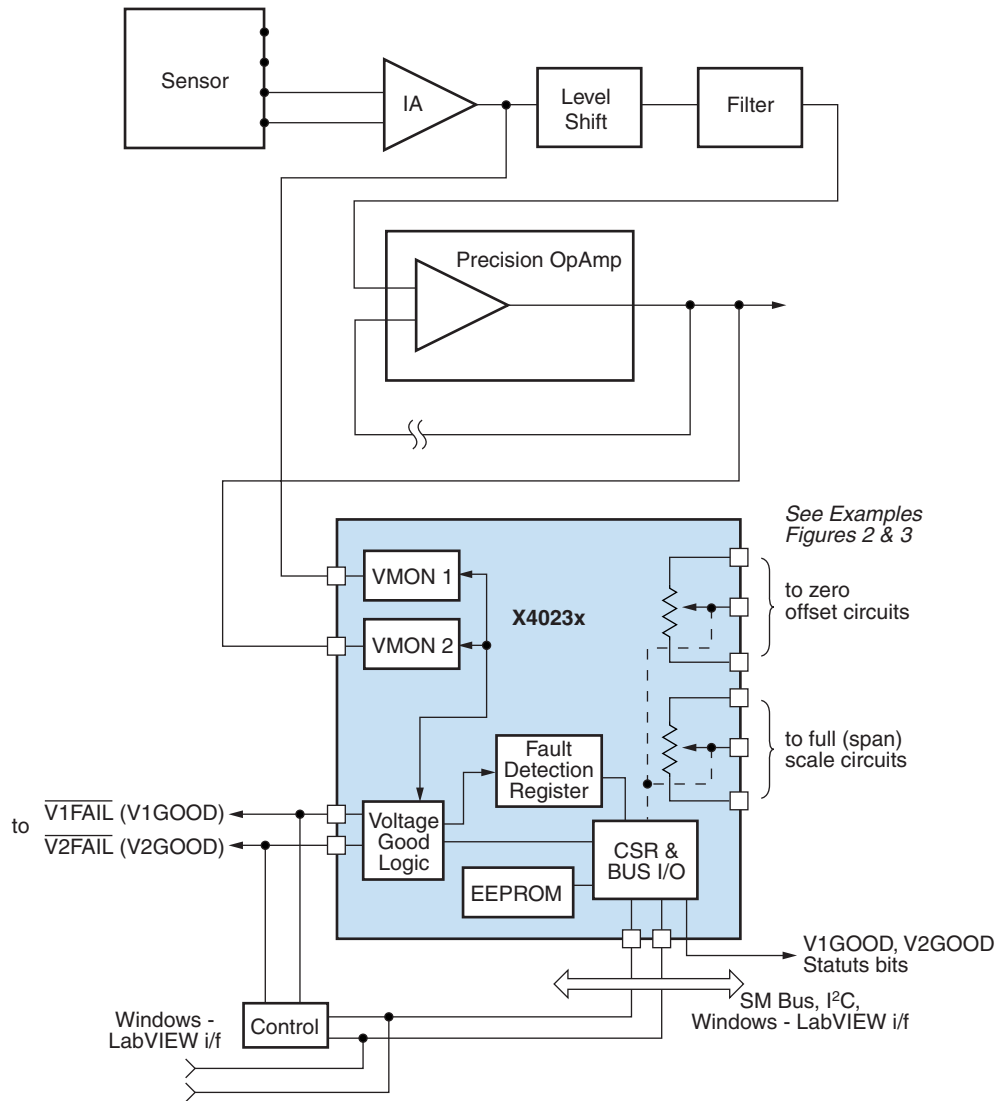

Figure 1. X4023 Used in Smart Sensor Signal Conditioning

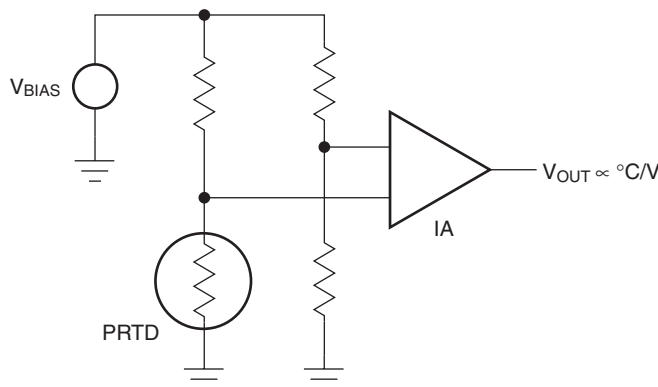

Figure 2A. Simple Temperature Sensor Diagram

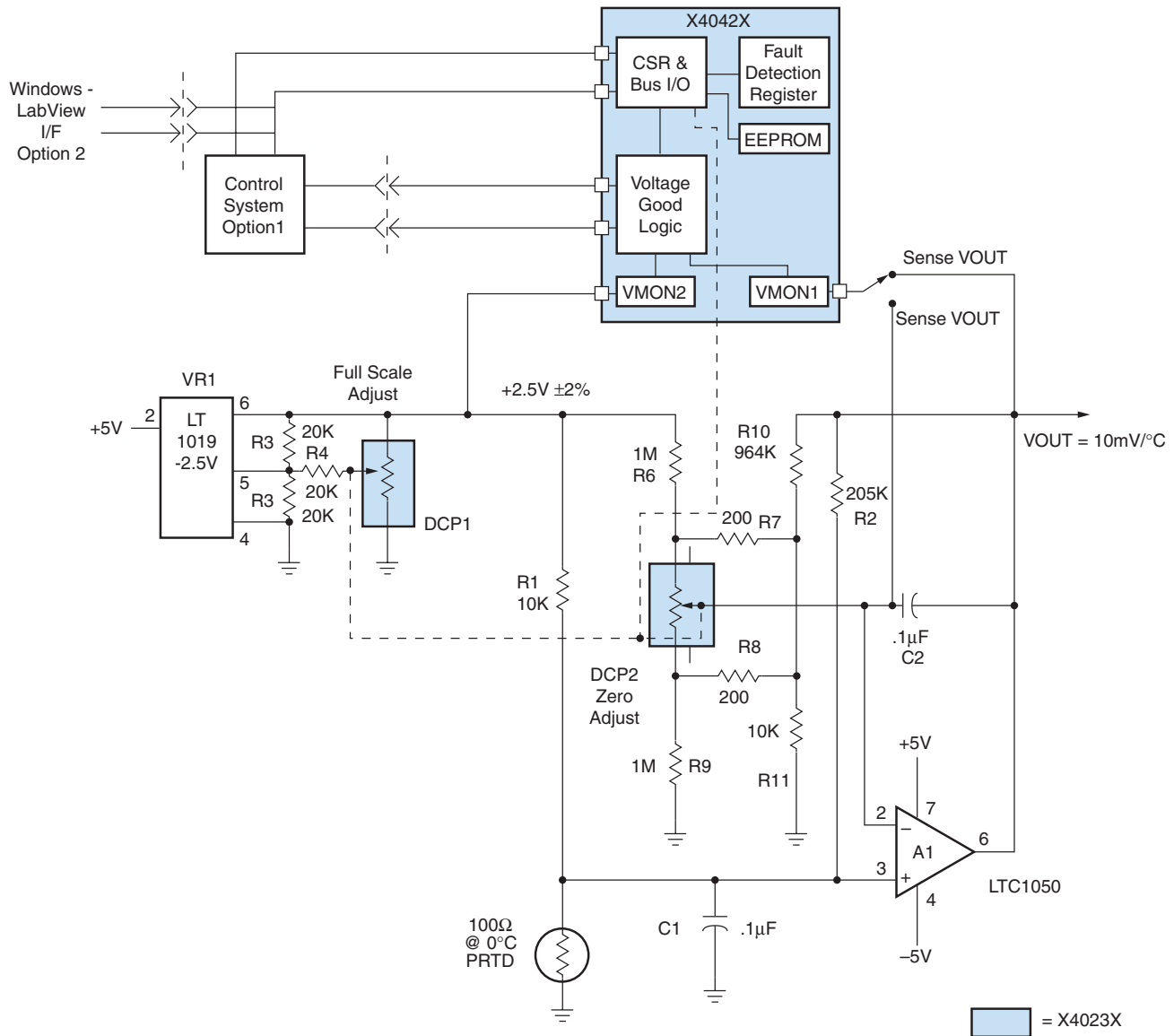

Figure 2B. Temperature Sensor Signal Condition Using X4023X

automated adjustment of the thermometer scale factor and span. Voltage monitor VMON2 monitors the current excitation by tracking the voltage.

The VMON2 pin can be programmed to monitor voltages between 1.2V to 4.7V at an accuracy of $\pm 50\text{mV}$ over temperature. So for instance VMON2 is programmed to monitor 2.5V to within 50mV. Once this voltage node reaches that trip point, the X4023x issues a “voltage good” signal (using the V2Fail signal pin) and

also registers the “voltage good” status into the fault detection register. This allows for automated tuning of the scale adjust circuit. By using the voltage monitors and status pins (V3Fail output), the XDCCP can be incremented or decremented in a control loop via 2-wire bus (SDA and SCL pins) until the desired excitation current is reached. This can be done in literally 100’s of milliseconds. Thus saving on manufacturing calibration time and cost. Note: Xicor offers additional programming

software that can be used for computer-driven manufacturing systems (see Windows-LabVIEW™ software later in the application note).

A1 is a noninverting amplifier with a gain of 100 which scales up the raw 100mV/C PRTD temperature signal to 0.01V/C. The DCP2 network implements a high resolution zero adjustment. Each increment in DCP2's (for the 256-tap options of the X4023x) setting will result in a 200mV shift in A1's output which is equivalent to a 0.02C zero adjustment. Again, VMON3 voltage monitor is used to monitor the output of the A1 amplifier. Hence automated zero adjustments can be achieved by monitoring the VMON3 voltage while incrementing or decrementing DCP2. By using the voltage monitors and status pins (V2Fail output), the XDCP can be incremented or decremented in a control loop via 2-wire bus (SDA and SCL pins) until the desired A1 output voltage is reached. Similarly, this can be done in literally 100's of milliseconds.

The net result of the combination of A1 and the associated circuit is a signal conditioning, precision temperature sensor that is compatible with full automation of the calibration process using the X4023x.

Programmable Pressure Transducer Circuit

This silicon piezoresistive-bridge pressure transducer (SPPT) must be supported by appropriate signal conditioning and calibration circuits. The signal conditioning circuit must also include stable, high resolution, preferably non-interactive, zero and span trims. The automation of the calibration of the sensor circuit is an enormous benefit in the production environment. Figure 3A employs a bridge that is current-biased and two amplifiers and Xicor's X4023x (two digitally controlled potentiometers and two voltage monitors for zero and full scale (gain) adjustments (for more details see Xicor Application Note 135).

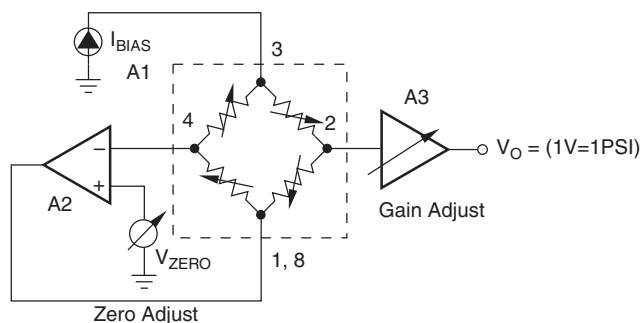

Figure 3A. Simple Pressure Sensor Diagram

Figure 3B provides a detail circuit of the pressure transducer signal conditioning circuit. Amplifier, A2, and the Xicor X4023x provide zero offset adjustment. To accomplish this, the bridge excitation voltage is programmably attenuated by the R2, R3, R4, R5 network applied to DCP1 (digitally controlled potentiometer). The range for zero adjustment is now a function of DCP used in a voltage divider configuration and the voltage range applied to the end terminals of the DCP1 (zero adjustments will range in the millivolts). VMON3 is used to monitor the bridge excitation voltage at the output of A2. Once this voltage node reaches a VMON3 trip point, the X4023x issues a “voltage good” signal (using the V3Fail signal pin) and also registers the “voltage good” status into the fault detection register. This allows for automated tuning of the zero adjust circuit. Hence automated zero adjustments can be achieved by monitoring the VMON3 voltage while incrementing or decrementing DCP1. By using the voltage monitors and status pins (V3Fail output), the XDCP can be incremented or decremented in a control loop via 2-wire bus (SDA and SCL pins) until the desired A2 output voltage is reached. This can be done in literally 100's of milliseconds.

Boosting the ~10mV/psi bridge signal by 100x to a convenient 1V/psi output level is the job of the A3 non-inverting amplifier via its feedback and calibration network consisting of R7 through R9 and DCP2 Bridge bias is provided by the A1 circuit which uses voltage reference D1 and current-sense resistor R1 to generate a constant-current bridge drive. Again, VMON2 voltage monitor is used to monitor the output of the A3 amplifier. Hence automated scale (span) adjustments can be

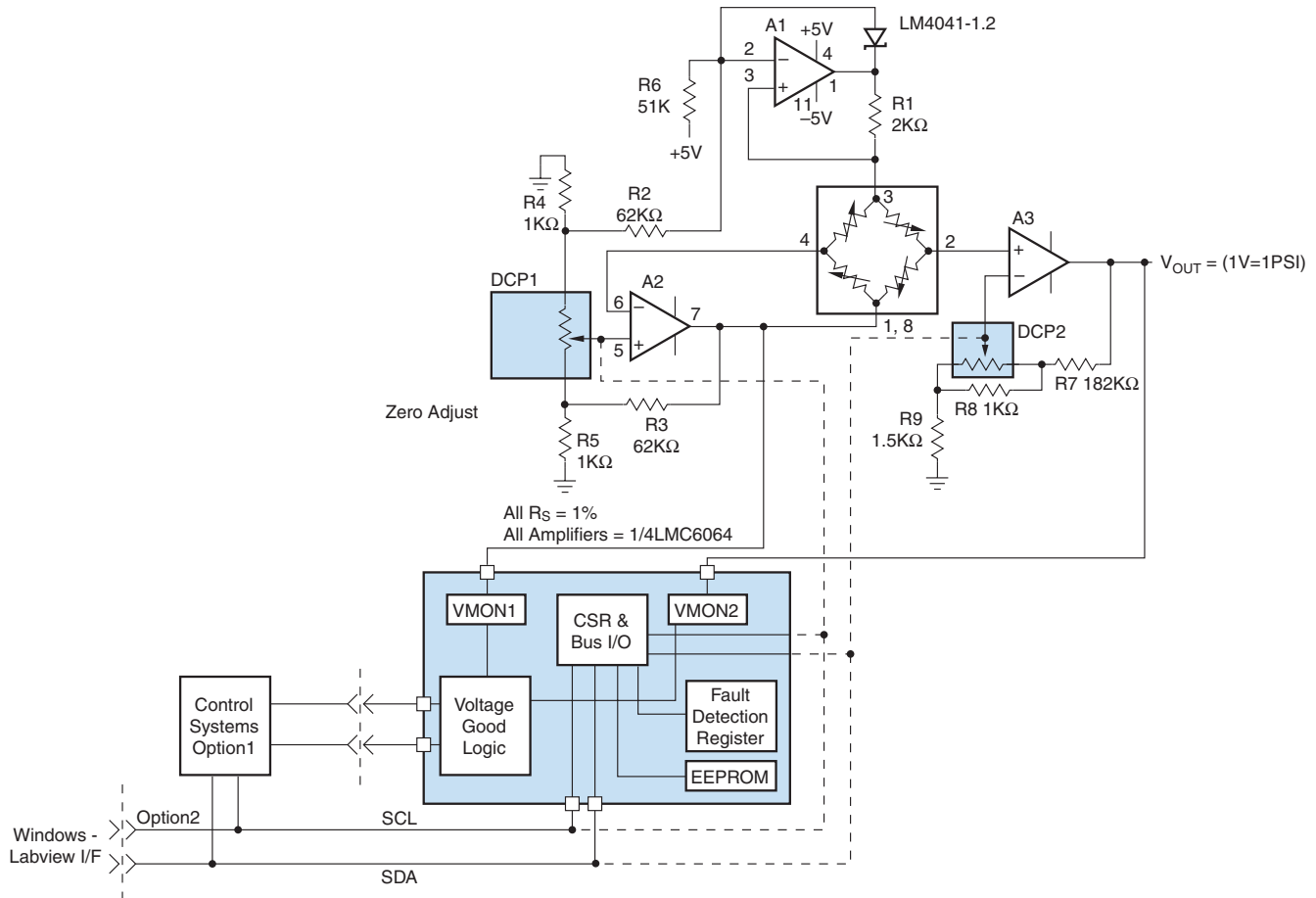

Figure 3B. Pressure Transducer Signal Condition Using X4023X

achieved by monitoring the VMON2 voltage while incrementing or decrementing DCP2. By using the voltage monitors and status pins (V2Fail output), the XDCP can be incremented or decremented in a control loop via 2-wire bus (SDA and SCL pins) until the

desired A3 output voltage is reached. Similarly, this can be done in literally 100's of milliseconds.

The signal conditioned precision pressure sensor is compatible with full automation of the calibration process using the X4023x.

Using Windows-LabVIEW Software to Automate Signal Conditioning in a Manufacturing Environment

To prototype the sensor signal conditioning circuit it will be required to program the digital potentiometers and monitor the key voltage level points in the circuit, Xicor offers a software programming tool that uses a standard computer with Windows 98 / NT / 2000 interface. The X4023x devices use a 2-wire (I2C like serial bus) interface. Through this interface, the digital potentiometer,

voltage monitors status, and general purpose EEPROM memory are accessible. Xicor's Windows-LabVIEW interface, is a software tool that can be used to send serial commands to the X4023x to program the digital potentiometer, voltage monitors status, and general purpose EEPROM memory. All of the commands are selectable and can be programmed individual via standards Window

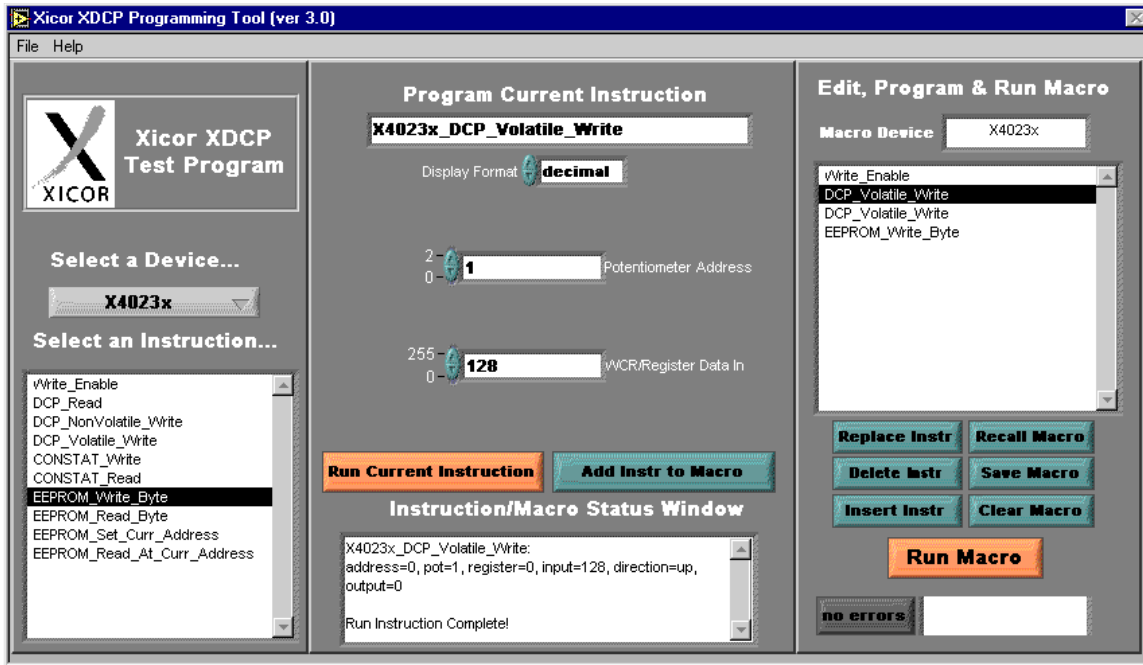

Figure 4. X4023x Programming Software

interface. Once the commands are executed (by executing a RUN or RUN Macro instruction), LabVIEW drivers emulate the command and send the 2-wire serial data stream via an available parallel port to the device under test. A typical serial bus instruction takes 100ms to 200ms to complete. The sensor signal condition circuit calibration, specifically, zero offset and gain span can be

completed in 100's of milliseconds!!! This tool is provided to Xicor's customers for FREE and is downloadable from Xicor's website at www.xicor.com.

For example, a typical instruction set to calibrate the zero offset could be as follows:

Command Sent I2C	Comments	Board Measurements (servo)
DCP_Volatile_Write	Set up initial potentiometer wiper position and continue to send this command with different wiper positions until the desire voltage is attained	The actual zero offset voltage is measured via the X4023x voltage monitor pin and pulls the V2FAIL signal pin low if the measured voltage has not reached the desired voltage
DCP_Nonvolatile_Write	Save the optimum wiper position to EEPROM memory so on power up position is restored	Once the V2FAIL signal goes HIGH this indicates that the desire voltage has been reached (within a level of accuracy). Stop incrementing / decrementing the wiper since the desired zero offset has been achieved

Note the above algorithm would require six additional pins in the sensor signal condition circuit, namely, SDA and SCL (serial bus interface pins) and two voltage monitor pins (V1MON and V2MON) and two status pins (V2FAIL and V3FAIL). If pin count and form-factor are of critical concern, this the interface can be

reduced to four pins: SDA, SCL, V1MON, and V2MON. Using a four pin approach would require an additional command to check for V2FAIL and V3FAIL pins via the CONSTAT (Control Status) register of the X4023x. Bits V2FS and V3FS of the CR register are latched, volatile flag bits which indicate the status of the



Voltage Monitor reset output pins V2FAIL and V3FAIL. Consequently, a typical instruction set to calibrate the zero offset could be as follows:

Command Sent I2C	Comments	Board Measurements (servo)
DCP_Volatile_Write	Set up initial potentiometer wiper position and continue to send this command with different wiper positions until the desired voltage is attained	The actual zero offset voltage is measured via the X4023x voltage monitor pin and pulls the V2FAIL signal pin low if the measured voltage has not reached the desired voltage
Constat_READ	Read the V2FS (and V3FS) voltage monitor status bits. Increment the wiper (DCP_Volatile_Write) if the desired voltage is not reached.	
DCP_Nonvolatile_Write	Save the optimum wiper position to EEPROM memory so on power up position is restored	Once the V2FAIL signal goes HIGH this indicates that the desired voltage has been reached (within a level of accuracy). Stop incrementing / decrementing the wiper since the desired zero offset has been achieved

Conclusions. The X4023x offers both the circuits and programming software to automate calibration of sensor signal conditioning circuits for low cost mass production. Zero offset and gain span calibration can be done in 100's of milliseconds. The programming interface can

be done in 4 or 6 pins while the digital interface is isolated from the analog sections of the X4023x thus providing for highly reliable designs and environmental integrity.