

# HB315

315MHz two-Port SAW Resonator

---



Approved by:
Checked by:
Issued by:

## SPECIFICATION

PRODUCT: SAW RESONATOR

MODEL: HB315 F-11

**HOPE MICROELECTRONICS CO., LIMITED**

The HB315 is a two-port, 180° surface-acoustic-wave (SAW) resonator in a low-profile metal F-11 case. It provides reliable, fundamental-mode, quartz frequency stabilization i.e. in transmitters or local oscillators operating at 315.000 MHz.

1.Package Dimension (F-11)

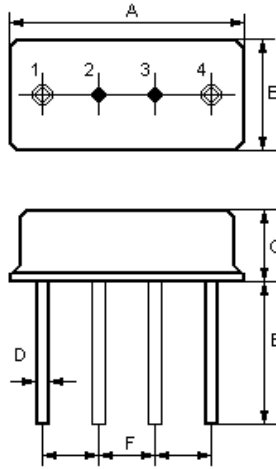

Pin	Configuration
1,4	Input / Output
2/3	Case Ground

Dimension	Data (unit: mm)
A	11.0±0.3
B	4.5±0.3
C	3.2±0.3
D	0.45±0.1
E	5.0±0.5
F	2.54±0.2

2.Marking

HB315.000

Color: Black or Blue

3.Equivalent LC Model and Test Circuit

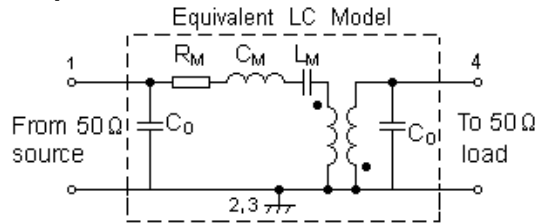

4.Typical Application Circuits

1) Low-Power Transmitter Application

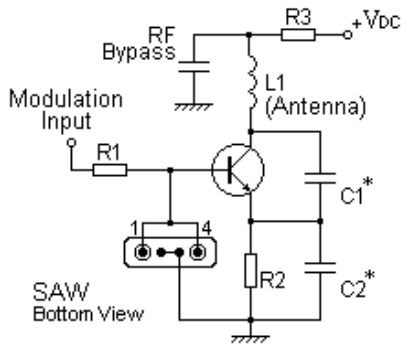

2) Local Oscillator Application

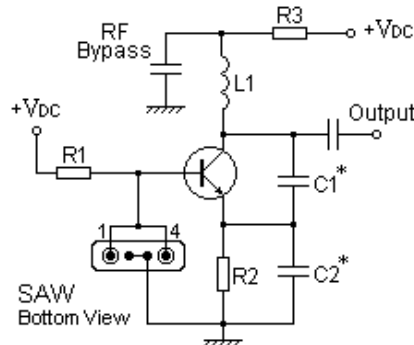

5.Typical Frequency Response

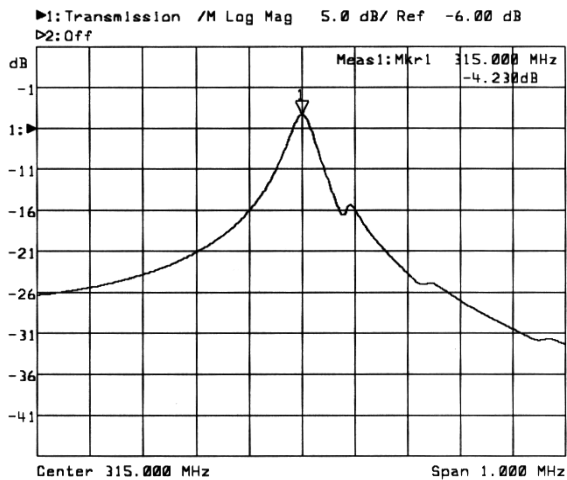

6.Temperature Characteristics

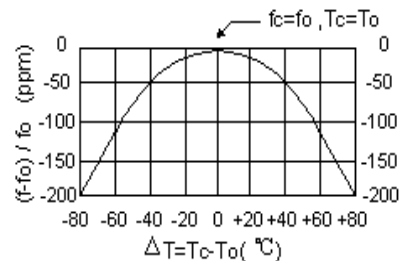

The curve shown above accounts for resonator contribution only and does not include LC component temperature characteristics.

## 7.Performance

### 7-1.Maximum Ratings

Rating	Value	Unit
CW RF Power Dissipation $P$	10	dBm
DC Voltage Between Any Two Pins $V_{DC}$	$\pm 30$	V
Storage Temperature Range $T_{stg}$	-40 to +85	$^{\circ}\text{C}$
Operating Temperature Range $T_A$	-10 to +60	$^{\circ}\text{C}$

### 7-2.Electronic Characteristics

Characteristic		Sym	Minimum	Typical	Maximum	Unit
Center Frequency (+25 $^{\circ}\text{C}$ )	Absolute Frequency	$f_C$	314.925		315.075	MHz
	Tolerance from 315.000MHz	$\Delta f_C$		$\pm 75$		kHz
Insertion Loss		IL		5.0	7.0	dB
Quality Factor	Unloaded Q	$Q_U$		15,060		
	50 $\Omega$ Loaded Q	$Q_L$		6,600		
Temperature Stability	Turnover Temperature	$T_0$	25		55	$^{\circ}\text{C}$
	Turnover Frequency	$f_0$		$f_C$		kHz
	Frequency Temperature Coefficient	FTC		0.032		ppm/ $^{\circ}\text{C}^2$
Frequency Aging	Absolute Value during the First Year	$ f_A $		$\leq 10$		ppm/yr
DC Insulation Resistance Between Any Two Pins			1.0			M $\Omega$
RF Equivalent RLC Model	Motional Resistance	$R_M$		78	124	$\Omega$
	Motional Inductance	$L_M$		593.8732		$\mu\text{H}$
	Motional Capacitance	$C_M$		0.4303		fF
	Shunt Static Capacitance	$C_0$	2.15	2.45	2.75	pF

**ⓘ CAUTION: Electrostatic Sensitive Device. Observe precautions for handling!**

2003. All Rights Reserved.

- The frequency  $f_C$  is the frequency of minimum IL with the resonator in the specified test fixture in a 50  $\Omega$  test system with VSWR  $\leq 1.2:1$ . Typically,  $f_{OSCILLATOR}$  or  $f_{TRANSMITTER}$  is less than the resonator  $f_C$ .
- Unless noted otherwise, case temperature  $T_C = +25^{\circ}\text{C} \pm 2^{\circ}\text{C}$ .
- Frequency aging is the change in  $f_C$  with time and is specified at +65 $^{\circ}\text{C}$  or less. Aging may exceed the specification for prolonged temperatures above +65 $^{\circ}\text{C}$ . Typically, aging is greatest the first year after manufacture, decreasing in subsequent years.
- Turnover temperature,  $T_0$ , is the temperature of maximum (or turnover) frequency,  $f_0$ . The nominal frequency at any case temperature,  $T_C$ , may be calculated from:  $f = f_0 [1 - \text{FTC} (T_0 - T_C)^2]$ . Typically, *oscillator*  $T_0$  is 20 $^{\circ}$  less than the specified *resonator*  $T_0$ .
- This equivalent RLC model approximates resonator performance near the resonant frequency and is provided for reference only. The capacitance  $C_0$  is the measured static (nonmotional) capacitance between either Pin 1 and ground or Pin 4 and ground. The measurement includes case parasitic capacitance.
- Derived mathematically from one or more of the following directly measured parameters:  $f_C$ , IL, 3 dB bandwidth,  $f_C$  versus  $T_C$ , and  $C_0$ .
- The specifications of this device are based on the test circuit shown above and subject to change or obsolescence without notice.
- Typically, equipment utilizing this device requires emissions testing and government approval, which is the responsibility of the equipment manufacturer.
- Our liability is only assumed for the Surface Acoustic Wave (SAW) component(s) per se, not for applications, processes and circuits implemented within components or assemblies.
- For questions on technology, prices and delivery, please contact our sales offices or e-mail [sales@hoperf.com](mailto:sales@hoperf.com).