

# AN7322/S

## 'Live' IC for PRC & Stereo Headphone Player

### ■ Description

The AN7322/S are the monolithic integrated circuits designed for use in PRC & Stereo Headphone Player. Signals from channel 1 and channel 2 are processed and mixed to produce a Live Effect output, centred at the frequency of 400Hz, with 3 different gain modes. Built-in switches allow the selection of Live OFF, Middle and Heavy effect.

### ■ Features

- Few external components.
- Selection modes : Live OFF, Middle and Heavy
- Built-in switches can be controlled by microprocessor

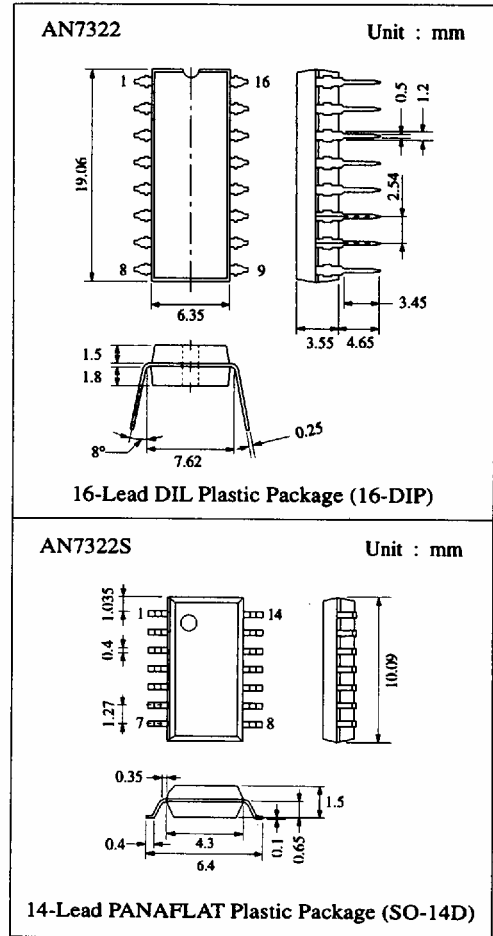

### ■ Block Diagram

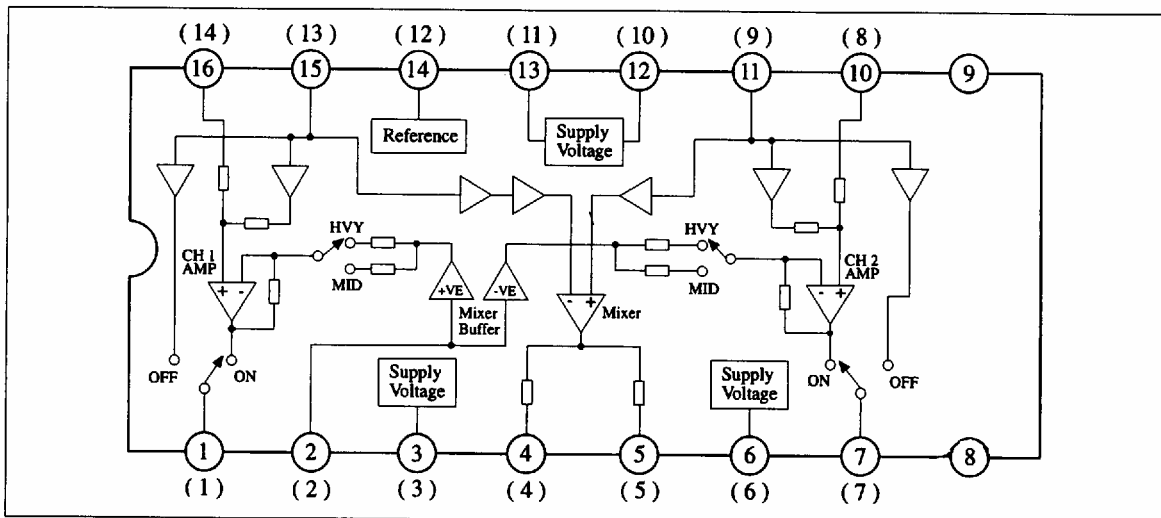

### ■ Absolute Maximum Ratings (Ta=25°C)

Item	Symbol	Rating	Unit
Supply Voltage	V <sub>CC</sub>	14	V
Supply Current	I <sub>CC</sub>	30	mA
Power Dissipation *1	P <sub>D</sub>	420	mW
Power Dissipation *2	P <sub>D</sub>	351	mW
Operating Ambient Temperature	T <sub>opr</sub>	-20 ~ +75	°C
Storage Temperature *1	T <sub>stg</sub>	-55 ~ +150	°C
Storage Temperature *2	T <sub>stg</sub>	-55 ~ +125	°C

Operating Supply Voltage Range: V<sub>CC</sub> = 1.8V ~ 6.9V

\*1 For DIL-16 Pin Plastic Package.

\*2 For DIL-14 Pin Plastic Package (SO-Type).

### ■ Electrical Characteristics (V<sub>CC</sub>=3V, f=1kHz, Ta=25°C)

Item	Symbol	Condition	min.	typ.	max.	Unit
Total Current	I <sub>tot</sub>	V <sub>sw</sub> = V <sub>in</sub> = 0 V	3.0	4.3	5.0	mA
Ripple Rejection	RR	V <sub>ripple</sub> = -20 dBV, V <sub>sw</sub> =0V, f=100Hz	35	45	-	dB
Channel 1 ( Live Off )		V <sub>sw</sub> = 0 V				
Path Gain	G <sub>v1</sub>	V <sub>in1</sub> = 100mV	-1	0	1.5	dB
Maximum Output voltage	V <sub>om1</sub>	THD = 1 %	0.15	0.25	-	V
Total Harmonic Distortion *1	THD <sub>1</sub>	V <sub>o1</sub> = 0.1 Vrms	-	0.15	0.5	%
Output Noise Voltage *1	V <sub>no1</sub>	V <sub>in1</sub> = 0 V	-	40	80	μV
Channel Separation	CS	V <sub>in1</sub> = 100mV, Measure V <sub>out2</sub>	35	45	-	dB
Channel Balance	CB	V <sub>in1</sub> =V <sub>in2</sub> =100mV	-1	0	1	dB
Channel 1 ( Live Mid )		V <sub>sw</sub> = 1.5V				
Total Harmonic Distortion *1	THD <sub>1</sub>	V <sub>o1</sub> = 0.1 Vrms	-	0.4	1.0	%
Output Noise Voltage *1	V <sub>no1</sub>	V <sub>in</sub> = 0 V	-	45	90	μV
Channel 1 Mixed Gain (1)	G <sub>vm1</sub>	V <sub>in1</sub> = 100mV, f = 400Hz	1.5	2.5	3.5	dB
Channel 2 Mixed Gain (2)	G <sub>vm2</sub>	V <sub>in1</sub> =100mV, f=400Hz, Measure V <sub>out2</sub>	-8.0	-6.0	-4.0	dB
Channel 1 ( Live Hvy )		V <sub>sw</sub> = 3 V				
Total Harmonic Distortion *1	THD <sub>1</sub>	V <sub>o1</sub> = 0.1 Vrms	-	0.4	1.0	%
Output Noise Voltage *1	V <sub>no1</sub>	V <sub>in</sub> = 0 V	-	60	100	μV
Channel 1 Mixed Gain (1)	G <sub>vm1</sub>	V <sub>in1</sub> = 100mV, f = 400Hz	4.5	5.8	7.0	dB
Channel 2 Mixed Gain (2)	G <sub>vm2</sub>	V <sub>in1</sub> =100mV, f=400Hz, Measure V <sub>out2</sub>	0.2	1.0	1.8	dB

\*1 DIN AUDIO filter used.

Note) Input only at V<sub>in1</sub> and measure at V<sub>out1</sub>, unless otherwise specified.

# AN7322/S

## ■ Pin

Pin No	Pin Name	Pin No	Pin Name
1 (1)	Channel 1 Output	9	NC
2 (2)	Mixer Input	10 (8)	Channel 2 Filter
3 (3)	Vcc	11 (9)	Channel 2 Input
4 (4)	Mixer Output 1	12 (10)	Ground
5 (5)	Mixer Output 2	13 (11)	Ripple Filter
6 (6)	Live switch	14 (12)	Reference Voltage
7 (7)	Channel 2 Output	15 (13)	Channel 1 Input
8	NC	16 (14)	Channel 1 Filter

Note) 1. The Ripple Filter pin is weaker in the surge of negative side than other pins.  
 2. The pin number in the bracket are for AN7322S.

## ■ Application Circuit

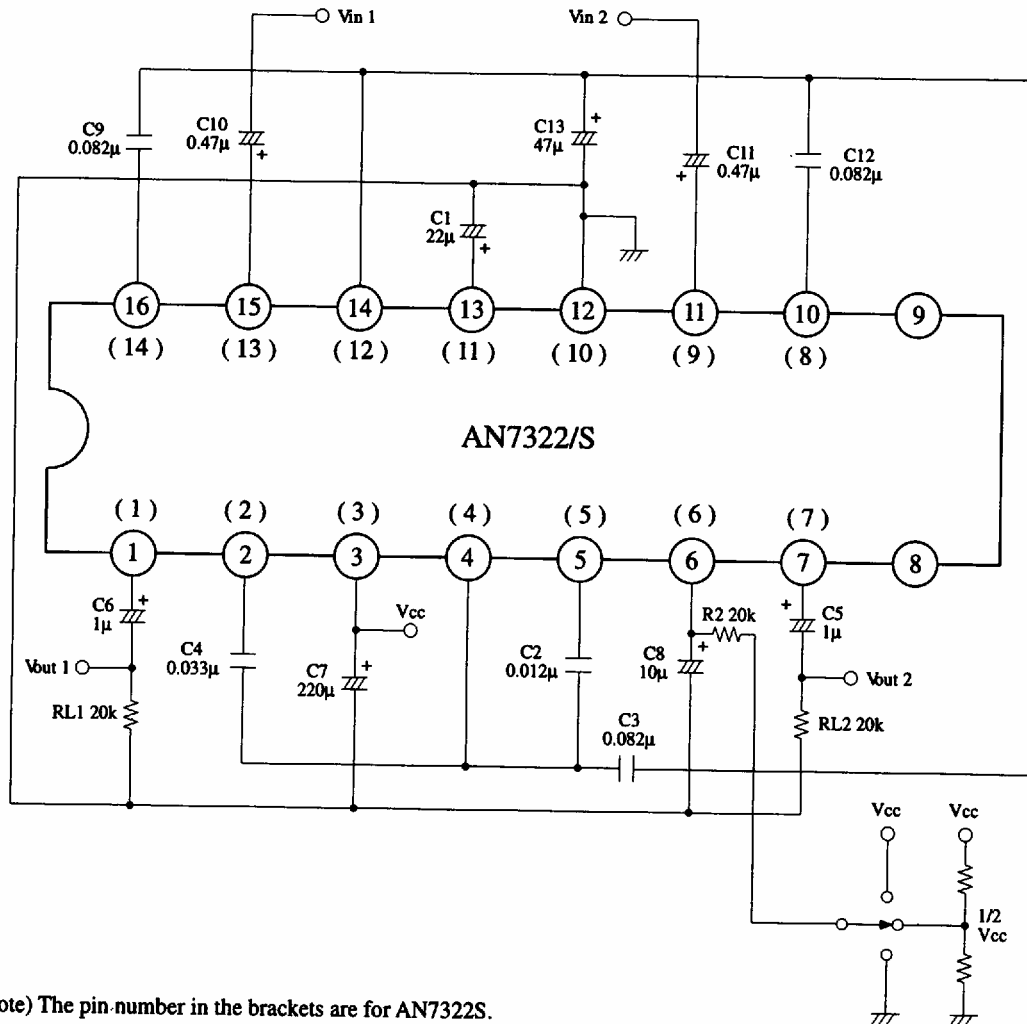

Note) The pin-number in the brackets are for AN7322S.

## ■ Pin Descriptions

Pin No.	Pin Name	DC Bias Voltage	Equivalent Circuit	Description	
1, 7 (1, 7)	Output	1.63		'LIVE' ON & OFF Output pin. Output impedance $\approx 2.6k\Omega$	
2 (2)	Mixer In	1.65		These 3 pins are used for high frequency cut for the mixed signal. The mixed signal is feedback to the L-Ch & R-Ch output amplifier respectively.	
4 (4)	Mixer Out 1	1.68			$f_1 = \frac{1}{2\pi R_1 C_2} \quad f_2 = \frac{1}{2\pi (R_1 // R_2) C_2}$
5 (5)	Mixer Out 2	1.68		NB : $f_1$ & $f_2$ can be varied by varying $C_2$ externally.	
3 (3)	Vcc				
6 (6)	'LIVE' Switch			This pin select 'LIVE' OFF, MID & HVY.  'LIVE' OFF (DC) = 0V 'LIVE' MID (DC) = $1/2 V_{cc}$ 'LIVE' HVY (DC) = $V_{cc}$	
10, 16 (8, 14)	Filter	0.95		These 2 pins are for low frequency cut before the original signal is mix with the mixed signal at the output amplifier.	

Note) The pin number in brackets are for AN7322S.

### ■ Pin Descriptions (Continue)

Pin No.	Pin Name	DC Bias Voltage	Equivalent Circuit	Description
11, 15 (9, 13)	Input	1.65		These are the inputs to the IC. These inputs can be from PRE & VOL block. I/P impedance $\approx 30k\Omega$
12 (10)	GND			
13 (11)	Ripple Filter	1.67		Connect with a capacitor to minimize ripple from Vcc.
14 (12)	Reference Voltage	1.67		This pin provide a fixed DC bias. The capacitor connect externally is to minimize oscillation.
8, 9	NC			

Note) The pin number in brackets are for AN7322S.

## ■ Supplementary Explanation

### ● Application Notes

This IC provides a 'LIVE' effect for stereo signal. It is situated between Pre-amplifier and Power amplifier. Signals from Left and Right channels are mixed to a certain level and this provides an ambient effect to the audible signal.

Below are 2 application examples of this IC.

#### (1) Application 1

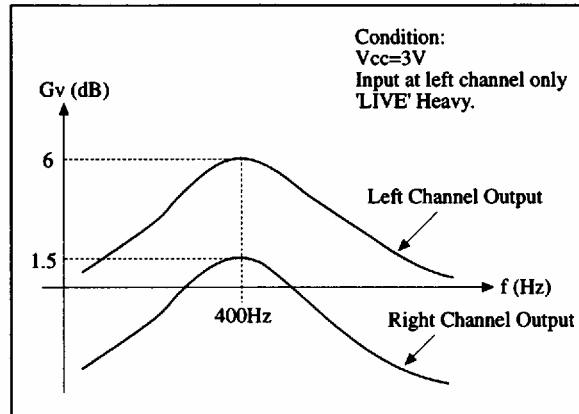
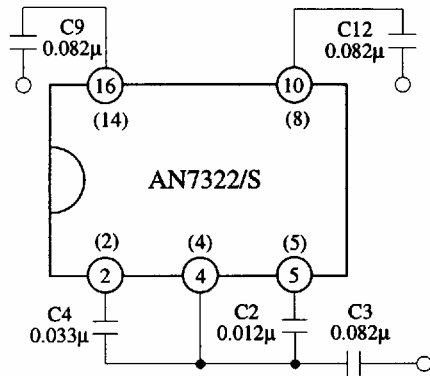

#### (2) Application 2

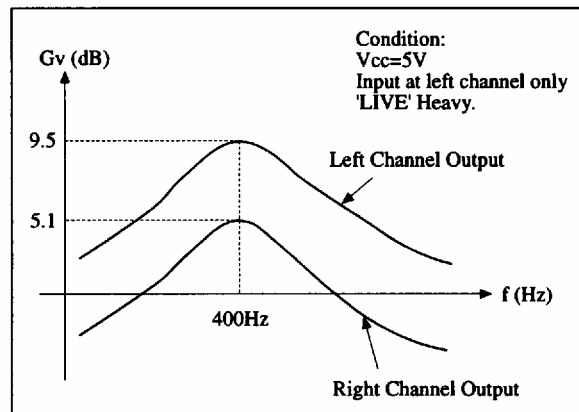
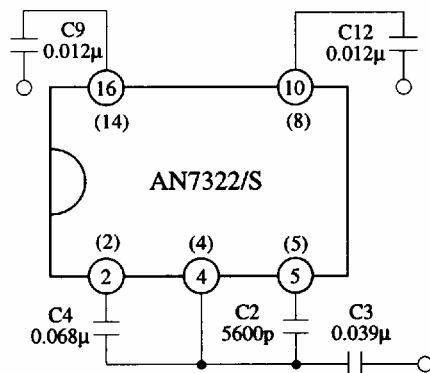

Other than the values shown above, the rest of the components values are the same as application circuit.

With the set of values shown above, this IC will give the same type of characteristics curve as the Application 1 except that the gain is higher. The characteristics curve are as shown on the above right diagram.

All the above characteristics curves are for 'LIVE' HEAVY only. In the MID position, the characteristics curve are the same as HEAVY except for the gain.

The gain for both 'LIVE' Mid and Heavy at 400Hz are as follows :-

'LIVE' MID	Application 1	Application 2
Left Channel Output	3dB	5.6dB
Right Channel Output	-5.6dB	-2dB

'LIVE' HEAVY	Application 1	Application 2
Left Channel Output	6dB	9.5dB
Right Channel Output	1.5dB	5.1dB

Note) The pin number in the brackets are for AN7322S.

