

FEATURES

- Complete Fully Calibrated Measurement/
Control System**
- Accurate RMS-to-DC Conversion from 50 Hz to 2.7 GHz**
- Input Dynamic Range of >60 dB**
-52 dBm to 8 dBm in 50 Ω
- Waveform and Modulation Independent**
(GSM/CDMA/TDMA, and so on)
- Linear-in-Decibels Output, Scaled 50 mV/dB**
- Law Conformance Error of 0.5 dB**
- All Functions Temperature and Supply Stable**
Operates from 4.5 V to 5.5 V at 24 mA
from -40°C to +85°C
- Power-Down Capability to 1.3 mW**

APPLICATIONS

- Power Amplifier Linearization/Control Loops**
- Transmitter Power Control**
- Transmitter Signal Strength Indication (TSSI)**
- RF Instrumentation**

GENERAL DESCRIPTION

The AD8362 is a true-rms-responding power detector having a 60 dB measurement range. It is intended for use in a variety of high frequency communication systems, and in instrumentation requiring an accurate response to signal power. It is easy to use, requiring only a single supply of 5 V and a few capacitors. It can operate from arbitrarily low frequencies to over 2.7 GHz and can accept inputs that have rms values from 1 mV to at least 1 V rms, with peak crest factors of up to six, exceeding the requirements for accurate measurement of CDMA signals.

The input signal is applied to a resistive ladder attenuator that comprises the input stage of a variable gain amplifier. The twelve tap points are smoothly interpolated using a proprietary technique to provide a continuously variable attenuator, which is controlled by a voltage applied to Pin VSET. The resulting signal is applied to a high performance broadband amplifier. Its output is measured by an accurate square law detector cell. The fluctuating output is then filtered and compared with the output of an identical squarer, whose input is a fixed dc voltage applied to Pin VTGT, usually the accurate reference of 1.25 V provided at Pin VREF.

The difference in the outputs of these squaring cells is integrated in a high gain error amplifier, generating a voltage at Pin VOUT with rail-to-rail capabilities. In a controller mode, this low noise output can be used to vary the gain of a host system's RF amplifier, thus balancing the set point against the input power. Optionally, the voltage at VSET may be a replica of the RF

REV. 0

Information furnished by Analog Devices is believed to be accurate and reliable. However, no responsibility is assumed by Analog Devices for its use, nor for any infringements of patents or other rights of third parties that may result from its use. No license is granted by implication or otherwise under any patent or patent rights of Analog Devices. Trademarks and registered trademarks are the property of their respective companies.

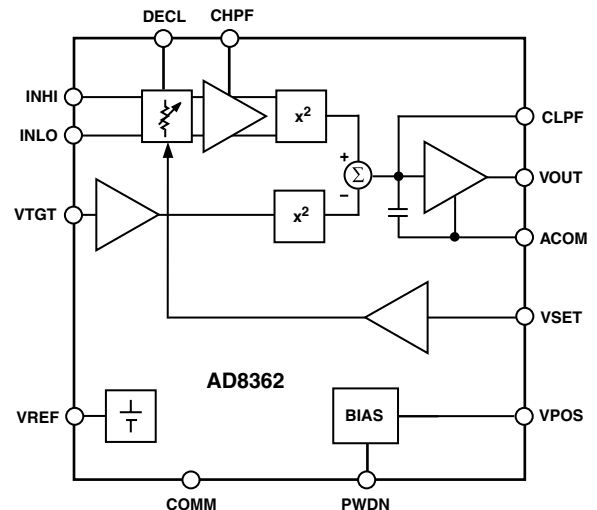
FUNCTIONAL BLOCK DIAGRAM

signal's amplitude modulation, in which case the overall effect is to remove the modulation component prior to detection and low pass filtering. The corner frequency of the averaging filter may be lowered without limit by the addition of an external capacitor at Pin CLPF, the AD8362 can be used to determine the true power of a high frequency signal having a complex low frequency modulation envelope (or simply as a low frequency rms voltmeter). The high-pass corner generated by its offset-nulling loop can be lowered by a capacitor added on Pin CHPF.

Used as a power measurement device, Pin VOUT is strapped to VSET, and the output is then proportional to the logarithm of the rms value of the input; that is, the reading is presented directly in decibels, and is conveniently scaled 1 V per decade, that is, 50 mV/dB; other slopes are easily arranged. In controller modes, the voltage applied to VSET determines the power level required at the input to null the deviation from the set point. The output buffer can provide high load currents.

The AD8362 is powered down by a logic high applied to the PWDN pin, i.e., the consumption is reduced to about 1.3 mW. It powers up within about 20 μ s to its nominal operating current of 20 mA at 25°C.

The AD8362 is supplied in a 16-lead TSSOP package for operation over the industrial temperature range of -40°C to +85°C. An evaluation board is available.

AD8362—SPECIFICATIONS ($V_S = 5\text{ V}$, $T = 25^\circ\text{C}$, $Z_0 = 50\ \Omega$, differential input drive via Balun¹, VTGT connected to V_{REF} , V_{OUT} tied to V_{SET} , unless otherwise noted.)

Parameter	Conditions	Min	Typ	Max	Unit
OVERALL FUNCTION					
Maximum Input Frequency			2.7		GHz
Input Power Range (Diff'l)	dB referred to 50 Ω Impedance level, $f \leq 2.7\text{ GHz}$, into 1:4 Balun ¹			-52	dBm
Nominal Low End of Range				+8	dBm
Nominal High End of Range					
Input Voltage Range (Diff'l)	RMS Voltage at Input Terminals, $f \leq 2.7\text{ GHz}$, into Input of the Device.		1.12		mV rms
Nominal Low End of Range			1.12		V rms
Nominal High End of Range					
Input Power Range (S-Sided)	Single-Ended Drive, CW Input, $f \leq 2.7\text{ GHz}$, into Input Resistive Network ²			-40	dBm
Nominal Low End of Range				0	dBm
Nominal High End of Range					
Input Voltage Range (S-Sided)	RMS Voltage at Input Terminals, $f \leq 2.7\text{ GHz}$		2.23		mV rms
Nominal Low End of Range			223		V rms
Nominal High End of Range					
Output Voltage Range	$R_L \geq 200\ \Omega$ to Ground			+100	mV
Nominal Low End of Range				+4.9	V
Nominal High End of Range					
Output Scaling (Log Slope)	In General, $V_S - 0.1\text{ V}$		50		mV/dB
Law Conformance Error	Over Central 60 dB Range, $f \leq 2.7\text{ GHz}$		± 0.5		dB
RF INPUT INTERFACE					
Input Resistance	Pins INHI, INLO, AC-Coupled Single-Ended Drive, wrt DECL Differential Drive		100		Ω
			200		Ω
OUTPUT INTERFACE					
Available Output Range	Pin VOUT $R_L \geq 200\ \Omega$ to Ground	0.5		4.9	V
Absolute Voltage Range					V
Nominal Low End of Range	Measurement mode, $f = 900\text{ MHz}$ $P_{IN} = -52\text{ dBm}$	0.32		0.48	V
Nominal High End of Range	Measurement mode, $f = 900\text{ MHz}$ $P_{IN} = +8\text{ dBm}$	3.44		3.52	V
Source/Sink Current	VOUT held at $V_S/2$, to 1% change		48		mA
Slew Rate Rising	$C_L = \text{Open}$		60		V/ μs
Slew Rate Falling	$C_L = \text{Open}$		5		V/ μs
Rise Time, 10%–90%	0.2 V to 1.8 V, CLPF = 0		45		ns
Fall Time, 90%–10%	1.8 V to 0.2 V, CLPF = 0		0.4		μs
Wide-Band Noise	CLPF = 1000 pF, $f_{SPOT} \leq 100\text{ kHz}$		70		nV/ $\sqrt{\text{Hz}}$
VSET INTERFACE					
Nominal Input Voltage Range	Pin VSET To $\pm 1\text{ dB}$ Error	0.5		3.75	V
Input Resistance			68		k Ω
Scaling (Log Slope)	$f = 900\text{ MHz}$	46	50	54	mV/dB
Scaling (Log Intercept)	$f = 900\text{ MHz}$, into 1:4 Balun	-64	-60	-56	dBm
		-77	-73	-69	dBV
VOLTAGE REFERENCE					
Output Voltage	Pin VREF 25°C	1.225	1.25	1.275	V
Temperature Sensitivity ³	$-40^\circ\text{C} \leq T_A \leq +85^\circ\text{C}$		0.08		mV/°C
Input Resistance			8		Ω
RMS TARGET INTERFACE					
Nominal Input Voltage Range	Pin VTGT Measurement Range = 60 dB, to $\pm 1\text{ dB}$ Error	0.625		2.5	V
Input Bias Current	VTGT = 1.25 V		-28		μA
	VTGT = 0 V		-52		μA
Incremental Input Resistance			52		k Ω

Parameter	Conditions	Min	Typ	Max	Unit
POWER DOWN INTERFACE	Pin PWDN				
Logic Level to Enable	Logic Low Enables			1	V
Logic Level to Disable	Logic High Disables	3			V
Input Current	Logic High		230		μ A
	Logic Low		5		μ A
Enable Time	From PWDN Low to VOUT within 10% of final value, CLPF = 1000 pF		14.5		ns
Disable Time	From PWDN High to VOUT within 10% of final value, CLPF = 1000 pF		2.5		us
POWER SUPPLY INTERFACE	Pin VPOS				
Supply Voltage		4.5	5	5.5	V
Quiescent Current			20	22	mA
Supply Current	When disabled		0.2		mA
900 MHz					
Dynamic Range	Error Referred to Best Fit Line (Linear Regression)				
	± 1 dB Linearity, CW Input		65		dB
	± 0.5 dB Linearity, CW Input		62		dB
Deviation vs. Temperature	Deviation from Output at 25°C				
	$-40^{\circ}\text{C} < T_A < +85^{\circ}\text{C}$; $P_{IN} = -45$ dBm		-1.7		dB
	$-40^{\circ}\text{C} < T_A < +85^{\circ}\text{C}$; $P_{IN} = -20$ dBm		-1.4		dB
	$-40^{\circ}\text{C} < T_A < +85^{\circ}\text{C}$; $P_{IN} = 5$ dBm		-1		dB
Logarithmic Slope		46	50	54	mV/dB
Logarithmic Intercept		-64	-60	-56	dBm
Deviation from CW Response	5.5 dB Peak-to-RMS Ratio (IS95 Reverse Link)		0.2		dB
	12 dB Peak-to-RMS Ratio (WCDMA 4 Channels)		0.2		dB
	18 dB Peak-to-RMS Ratio (WCDMA 15 Channels)		0.5		dB
1.9 GHz					
Dynamic Range	Error Referred to Best Fit Line (Linear Regression)				
	± 1 dB Linearity, CW Input		65		dB
	± 0.5 dB Linearity, CW Input		62		dB
Deviation vs. Temperature	Deviation from Output at 25°C				
	$-40^{\circ}\text{C} < T_A < +85^{\circ}\text{C}$; $P_{IN} = -45$ dBm		-0.6		dB
	$-40^{\circ}\text{C} < T_A < +85^{\circ}\text{C}$; $P_{IN} = -20$ dBm		-0.5		dB
	$-40^{\circ}\text{C} < T_A < +85^{\circ}\text{C}$; $P_{IN} = 5$ dBm		-0.3		dB
Logarithmic Slope			51		mV/dB
Logarithmic Intercept			-59		dBm
Deviation from CW Response	5.5 dB Peak-to-RMS Ratio (IS95 Reverse Link)		0.2		dB
	12 dB Peak-to-RMS Ratio (WCDMA 4 Channels)		0.2		dB
	18 dB Peak-to-RMS Ratio (WCDMA 15 Channels)		0.5		dB
2.2 GHz					
Dynamic Range	Error Referred to Best Fit Line (Linear Regression)				
	± 1 dB Linearity, CW Input		65		dB
	± 0.5 dB Linearity, CW Input		65		dB
Deviation vs. Temperature	Deviation from Output at 25°C				
	$-40^{\circ}\text{C} < T_A < +85^{\circ}\text{C}$; $P_{IN} = -45$ dBm		-1.8		dB
	$-40^{\circ}\text{C} < T_A < +85^{\circ}\text{C}$; $P_{IN} = -20$ dBm		-1.6		dB
	$-40^{\circ}\text{C} < T_A < +85^{\circ}\text{C}$; $P_{IN} = 5$ dBm		-1.3		dB
Logarithmic Slope			50.5		mV/dB
Logarithmic Intercept			-61		dBm
Deviation from CW Response	5.5 dB Peak-to-RMS Ratio (IS95 Reverse Link)		0.2		dB
	12 dB Peak-to-RMS Ratio (WCDMA 4 Channels)		0.2		dB
	18 dB Peak-to-RMS Ratio (WCDMA 15 Channels)		0.5		dB

AD8362

Parameter	Conditions	Min	Typ	Max	Unit
2.7 GHz					
Dynamic Range	Error Referred to Best Fit Line (Linear Regression)				
	±1 dB Linearity, CW Input		63		dB
	±0.5 dB Linearity, CW Input		62		dB
Deviation vs. Temperature	Deviation from Output at 25°C				
	-40°C < T _A < +85°C; P _{IN} = -40 dBm		-5.3		dB
	-40°C < T _A < +85°C; P _{IN} = -15 dBm		-5.5		dB
	-40°C < T _A < +85°C; P _{IN} = 15 dBm		-4.8		dB
Logarithmic Slope			50.5		mV/dB
Logarithmic Intercept			-58		dBm
Deviation from CW Response	5.5 dB Peak-to-RMS Ratio (IS95 Reverse Link)		0.2		dB
	12 dB Peak-to-RMS Ratio (WCDMA 4 Channels)		0.2		dB
	18 dB Peak-to-RMS Ratio (WCDMA 15 Channels)		0.4		dB

NOTES

¹1:4 balun transformer, M/A-COM ETC 1.6-4-2-3

²Resistive network consists of 33 Ω shunt and 25 Ω series.

³See TPC 29

Specifications subject to change without notice.

ABSOLUTE MAXIMUM RATINGS*

Supply Voltage V_{POS}	5.5 V
Input Power (into input of device)	13 dBm
Equivalent Voltage	2 V rms
Internal Power Dissipation	500 mW
θ_{JA}	125°C/W
Maximum Junction Temperature	125°C/W
Operating Temperature Range	-40°C to +85°C
Storage Temperature Range	-65°C to +150°C
Lead Temperature Range (Soldering 60 sec)	300°C

*Stresses above those listed under Absolute Maximum Ratings may cause permanent damage to the device. This is a stress rating only; functional operation of the device at these or any other conditions above those indicated in the operational section of this specification is not implied. Exposure to absolute maximum rating conditions for extended periods may affect device reliability.

PIN CONFIGURATION

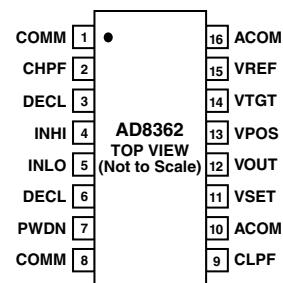

ORDERING GUIDE

Model	Temperature Range	Package Option
AD8362ARU	-40°C to +85°C	Tube, 16-Lead TSSOP
AD8362ARU-REEL7		7" Tape and Reel
AD8362-EVAL		Evaluation Board

CAUTION

ESD (electrostatic discharge) sensitive device. Electrostatic charges as high as 4000 V readily accumulate on the human body and test equipment and can discharge without detection. Although the AD8362 features proprietary ESD protection circuitry, permanent damage may occur on devices subjected to high energy electrostatic discharges. Therefore, proper ESD precautions are recommended to avoid performance degradation or loss of functionality.



AD8362

PIN FUNCTION DESCRIPTIONS

Pin No.	Mnemonic	Description	Equivalent Circuit
1, 8	COMM	Common Connection. Connect via low impedance to system common.	
2	CHPF	Input HPF. Connect to common via a capacitor to determine 3 dB point of input signal high-pass filter.	
3, 6	DECL	Decoupling Terminals for INHI and INLO. Connect to common via a large capacitance to complete input circuit.	
4	INHI	High Signal Input Terminal. Part of a differential input port with INLO.	Circuit A
5	INLO	Low Signal Input Terminal. Part of a differential input port with INHI.	Circuit A
7	PWDN	Disable/Enable Control Input. Apply logic high voltage to shut down the AD8362.	
9	CLPF	Connection for Loop Filter Integration (Averaging) Capacitor, the other pin of which is usually grounded via a resistor to improve loop stability and response time.	
10, 16	ACOM	Analog Common Connection for Output Amplifier	
11	VSET	The voltage applied to this pin sets the decibel value of the required RF input voltage that results in zero current out of pin CLPF and thus the loop integrating capacitor.	Circuit B
12	VOUT	Output of Error Amplifier. In measurement mode, normally connected directly to VSET.	Circuit C
13	VPOS	Connect to 5 V Power Supply	
14	VTGT	The logarithmic intercept voltage is proportional to the voltage applied to this pin. The use of a lower target voltage increases the crest factor capacity.	Circuit D
15	VREF	General-Purpose Reference Voltage Output of 1.25 V (usually connected only to VTGT)	Circuit E

Equivalent Circuits

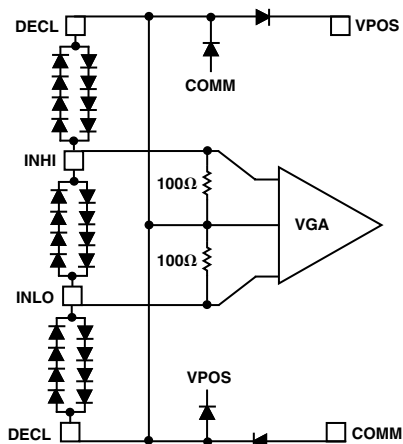

Circuit A

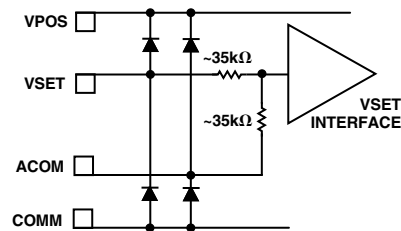

Circuit B

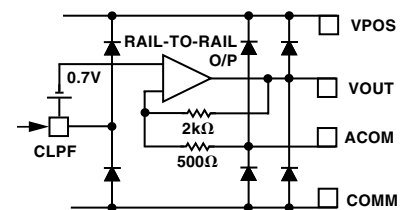

Circuit C

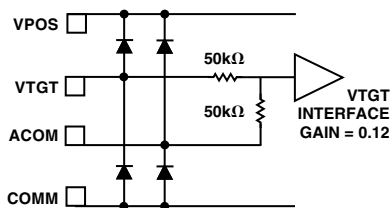

Circuit D

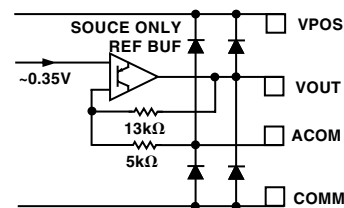

Circuit E

Typical Performance Characteristics—AD8362

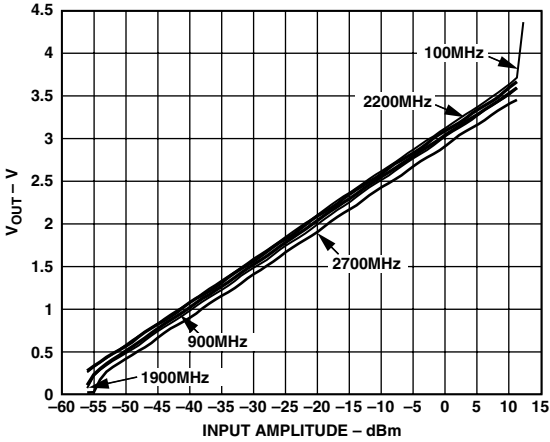

TPC 1. Output Voltage (V_{OUT}) vs. Input Amplitude (dBm), Frequencies 100 MHz, 900 MHz, 1900 MHz, 2200 MHz, 2700 MHz, Sine Wave, Differential Drive

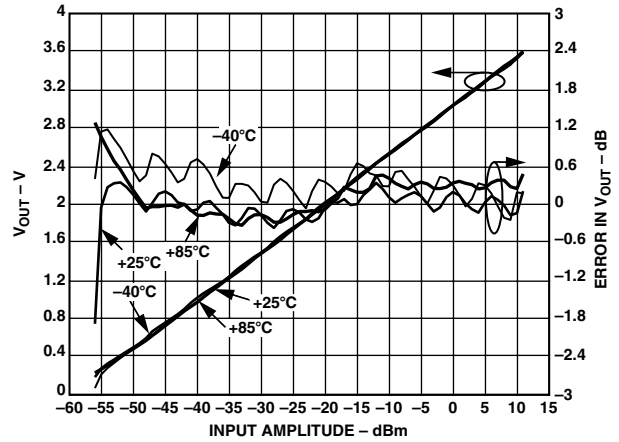

TPC 4. V_{OUT} and Law Conformance vs. Input Amplitude, Frequency 1900 MHz, Sine Wave, Temperature -40°C , $+25^{\circ}\text{C}$, and $+85^{\circ}\text{C}$

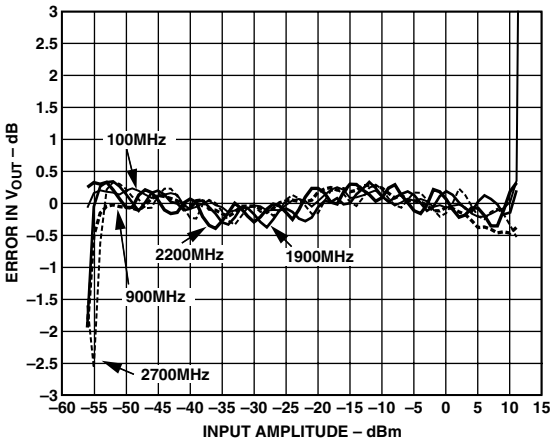

TPC 2. Logarithmic Law Conformance vs. Input Amplitude, Frequencies 100 MHz, 900 MHz, 1900 MHz, 2200 MHz, 2700 MHz, Sine Wave, Differential Drive

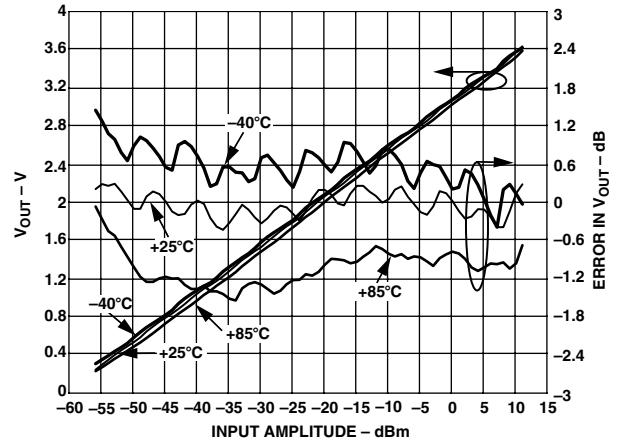

TPC 5. V_{OUT} and Law Conformance vs. Input Amplitude, Frequency 2200 MHz, Sine Wave, Temperature -40°C , $+25^{\circ}\text{C}$, and $+85^{\circ}\text{C}$

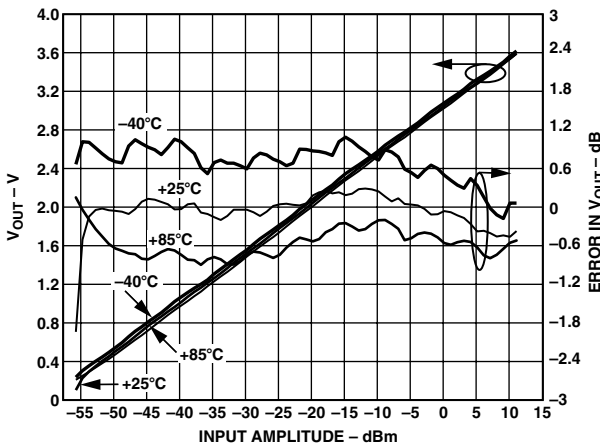

TPC 3. V_{OUT} and Law Conformance vs. Input Amplitude, Frequency 900 MHz, Sine Wave, Temperature -40°C , $+25^{\circ}\text{C}$, and $+85^{\circ}\text{C}$

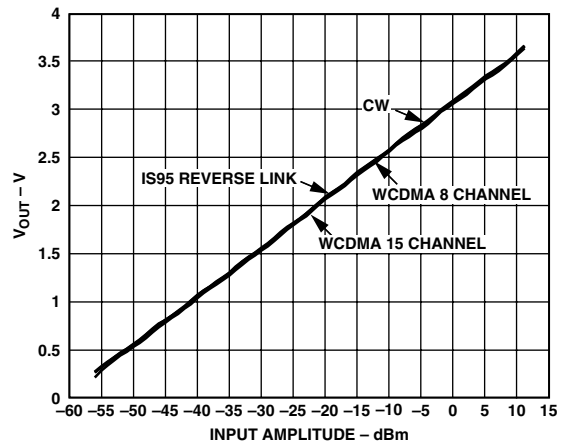

TPC 6. V_{OUT} vs. Input Amplitude with Different Waveforms, CW, IS95-ReverseLink, WCDMA 8-Channel, WCDMA 15-Channel, Frequency 900 MHz

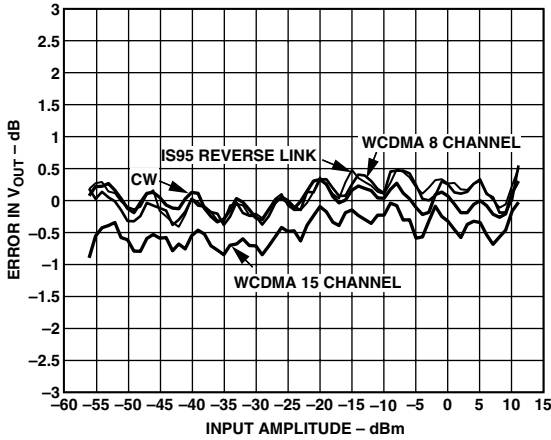

TPC 7. Output Error from CW Linear Reference vs. Input Amplitude with Different Waveforms, CW, IS95 Reverse Link, WCDMA 8-Channel, WCDMA 15-Channel, Frequency 900 MHz

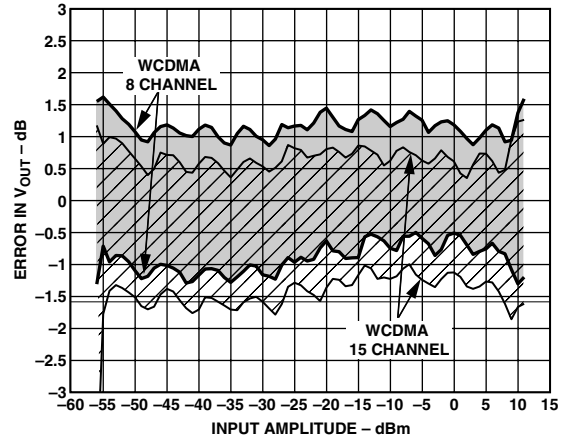

TPC 10. Output Error from CW Linear Reference vs. Input Amplitude, 3 Sigma to Either Side of Mean, with WCDMA 8-Channel, WCDMA 15-Channel, Frequency 1900 MHz

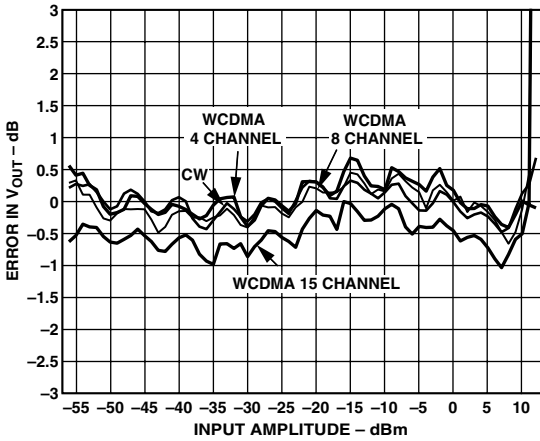

TPC 8. Output Error from CW Linear Reference vs. Input Amplitude with Different WCDMA Channel Loading, 4-Channel, 8-Channel, 15-Channel, Frequency 2200 MHz

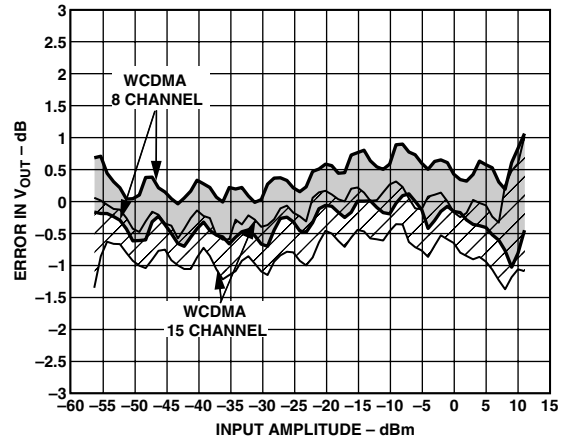

TPC 11. Output Error from CW Linear Reference vs. Input Amplitude, 3 Sigma to Either Side of Mean, with WCDMA 8-Channel, WCDMA 15-Channel, Frequency 2200 MHz

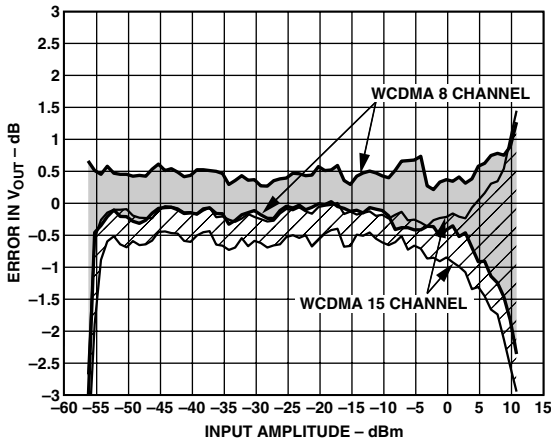

TPC 9. Output Error from CW Linear Reference vs. Input Amplitude, 3 Sigma to Either Side of Mean, with WCDMA 8-Channel, WCDMA 15-Channel, Frequency 1900 MHz

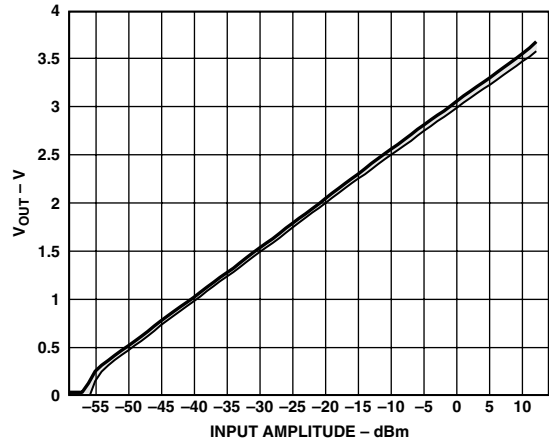

TPC 12. V_{OUT} vs. Input Amplitude, 3 Sigma to Either Side of Mean, Sine Wave, Frequency 900 MHz, Part-to-Part Variation

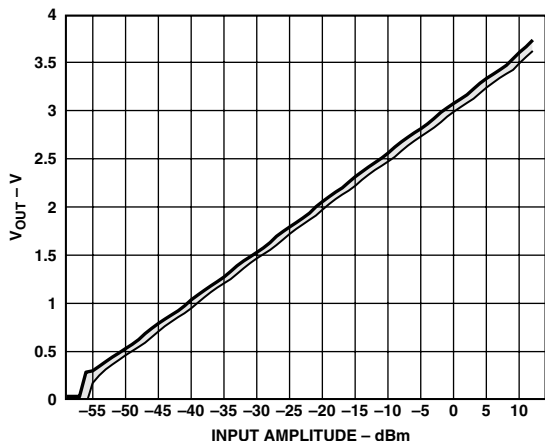

TPC 13. V_{OUT} vs. Input Amplitude, 3 Sigma to Either Side of Mean, Sine Wave, Frequency 1900 MHz, Part-to-Part Variation

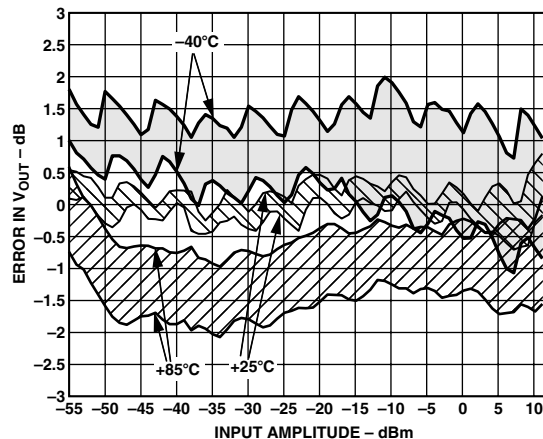

TPC 16. Logarithmic Law Conformance vs. Input Amplitude, 3 Sigma to Either Side of Mean, Sine Wave, Frequency 2200 MHz, Temperature -40°C , $+25^{\circ}\text{C}$, and $+85^{\circ}\text{C}$

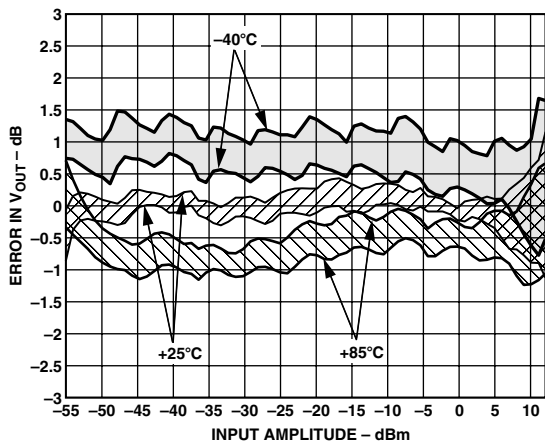

TPC 14. Logarithmic Law Conformance vs. Input Amplitude, 3 Sigma to Either Side of Mean, Sine Wave, Frequency 900 MHz, Temperature -40°C , $+25^{\circ}\text{C}$, and $+85^{\circ}\text{C}$

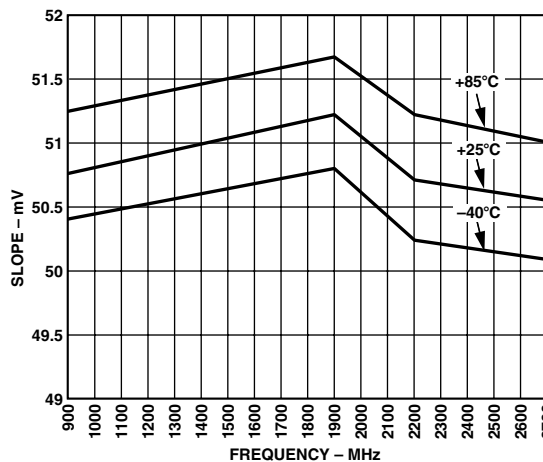

TPC 17. Logarithmic Slope vs. Frequency, Temperature -40°C , $+25^{\circ}\text{C}$, and $+85^{\circ}\text{C}$

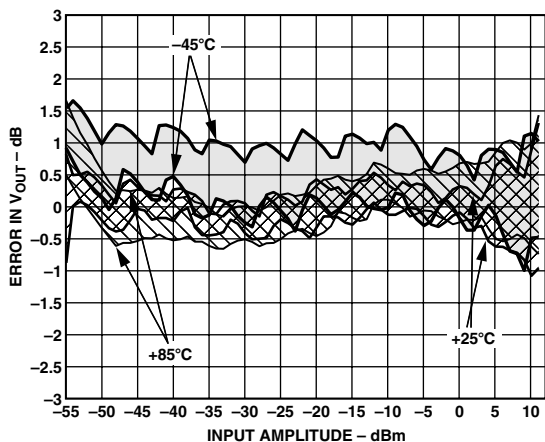

TPC 15. Logarithmic Law Conformance vs. Input Amplitude, 3 Sigma to Either Side of Mean, Sine Wave, Frequency 1900 MHz, Temperature -40°C , $+25^{\circ}\text{C}$, and $+85^{\circ}\text{C}$

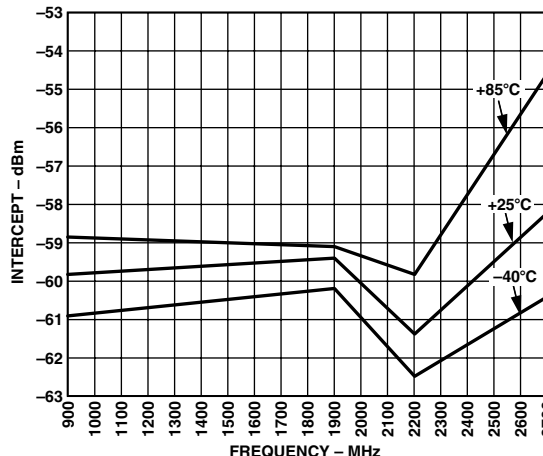

TPC 18. Logarithmic Intercept vs. Frequency, Temperature -40°C , $+25^{\circ}\text{C}$, and $+85^{\circ}\text{C}$

AD8362

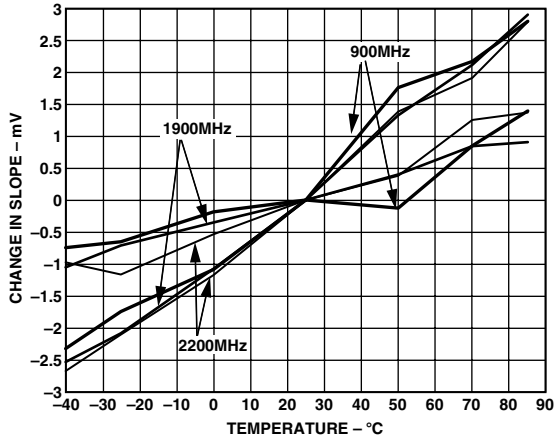

TPC 19. Change in Logarithmic Slope vs. Temperature, 3 Sigma to Either Side of Mean, Frequencies 900 MHz, 1900 MHz, 2200 MHz

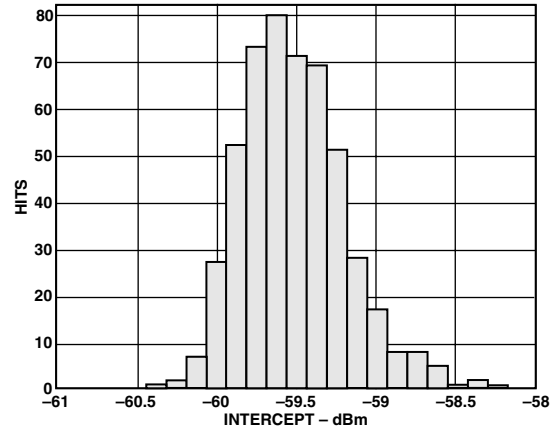

TPC 22. Logarithmic Intercept Distribution, Frequency 900 MHz

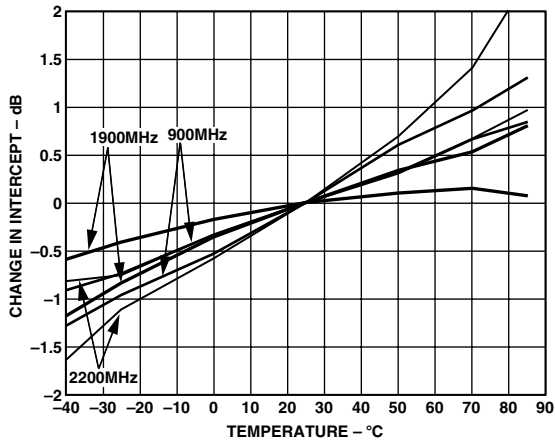

TPC 20. Change in Logarithmic Intercept vs. Temperature, 3 Sigma to Either Side of Mean, Frequencies 900 MHz, 1900 MHz, and 2200 MHz

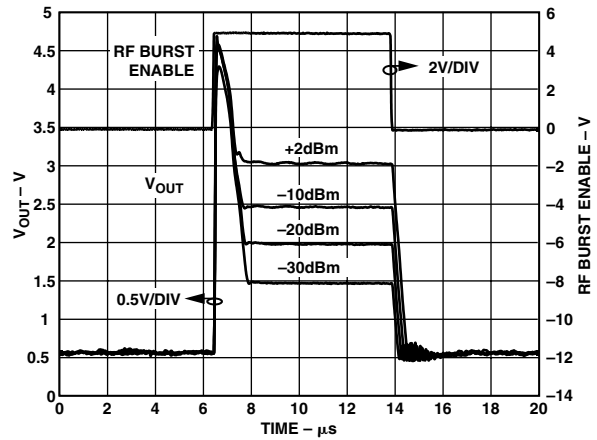

TPC 23. Output Response to RF Burst Input for Various RF Input Levels, Carrier Frequency 900 MHz, $C_{LPF} = 0$

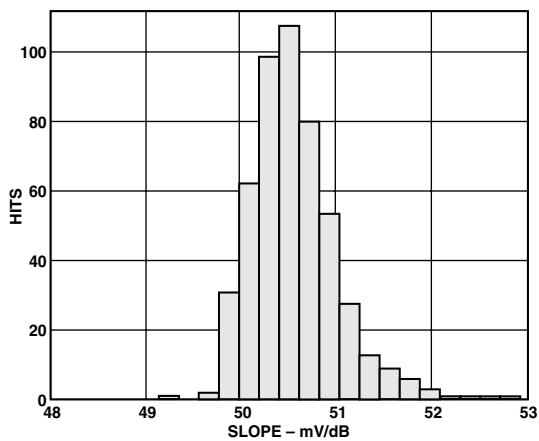

TPC 21. Slope Distribution, Frequency 900 MHz

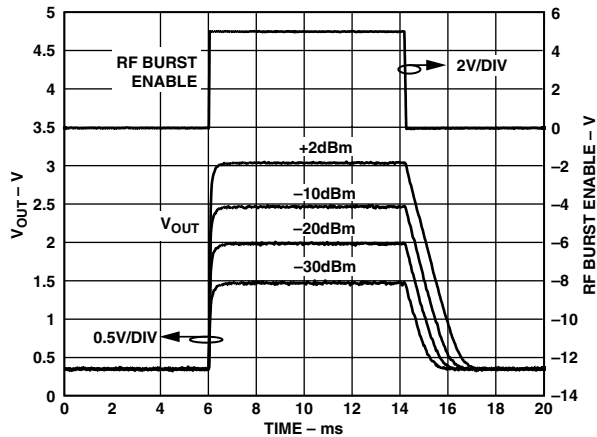

TPC 24. Output Response to RF Burst Input for Various RF Input Levels, Carrier Frequency 900 MHz, $CLPF = 0.1 \mu F$

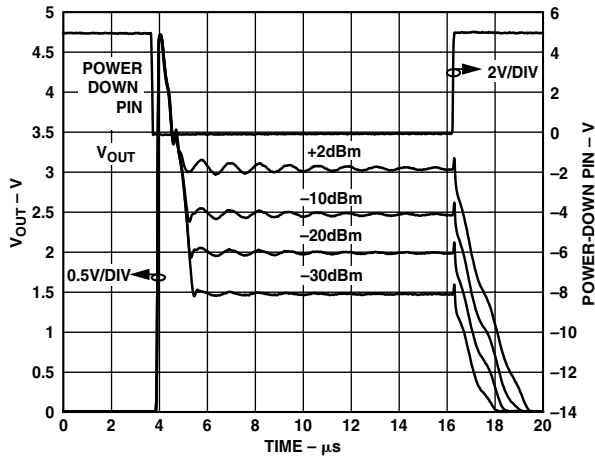

TPC 25. Output Response Using Power-Down Mode for Various RF Input Levels, Carrier Frequency 900 MHz, $C_{LPF} = 0$

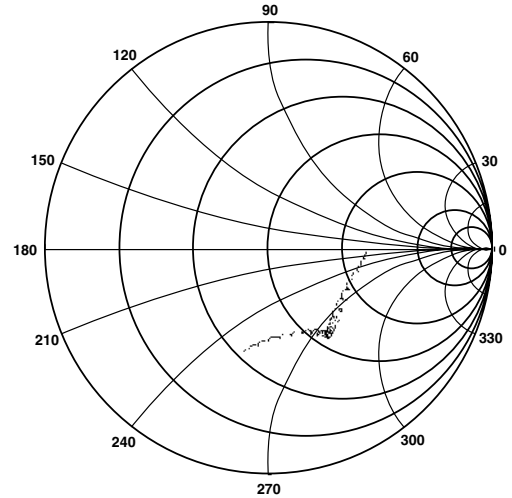

TPC 28. Input Impedance, $Z_O = 50 \Omega$, Differential Drive

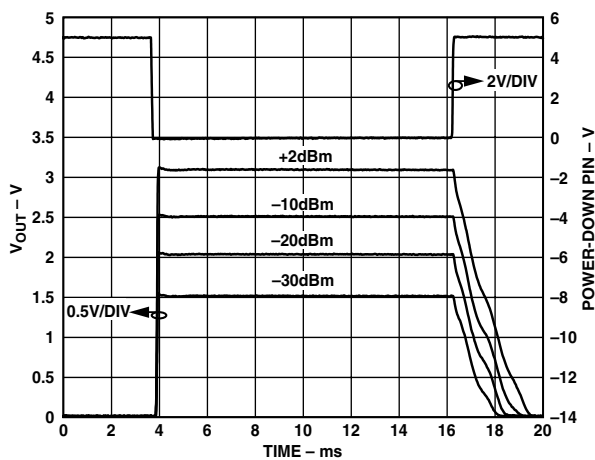

TPC 26. Output Response Using Power-Down Mode for Various RF Input Levels, Carrier Frequency 900 MHz, $C_{LPF} = 0.1 \mu F$

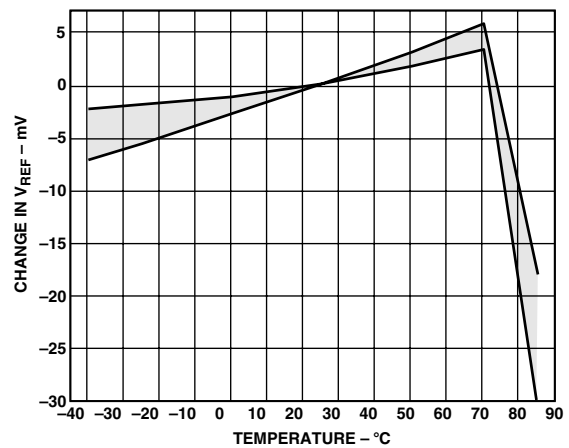

TPC 29. Change in V_{REF} vs. Temperature, 3 Sigma to Either Side of Mean

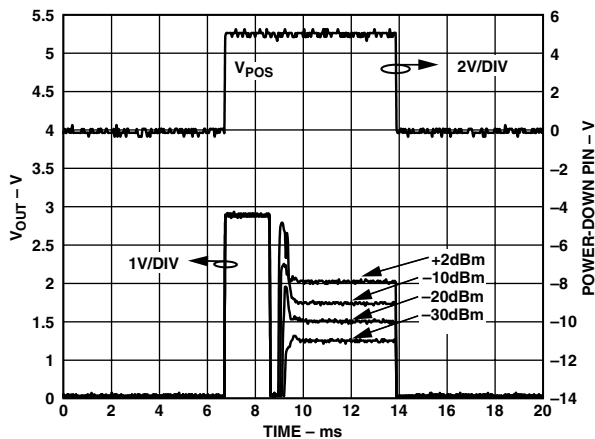

TPC 27. Output Response to Gating on Power Supply for Various RF Input Levels, Carrier Frequency 900 MHz, $C_{LPF} = 0$

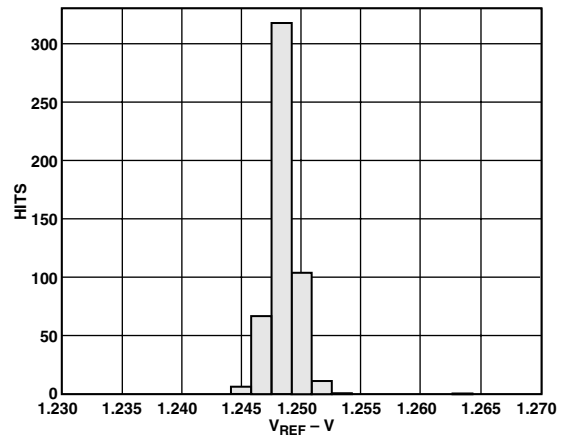

TPC 30. V_{REF} Distribution

AD8362

CHARACTERIZATION SETUP

Equipment

The general hardware configuration used for most of the AD8362 characterization is shown in Figure 1. The signal source used was a Rohde & Schwarz SMIQ03B. A 1:4 balun transformer was used to transform the single-ended RF signal to differential form. For the response measurements in TPC 23 and TPC 24, the configuration shown in Figure 2, was used for TPC 25 and TPC 26 the configuration shown in Figure 3 was used, and for TPC 27 the configuration shown in Figure 4 was used.

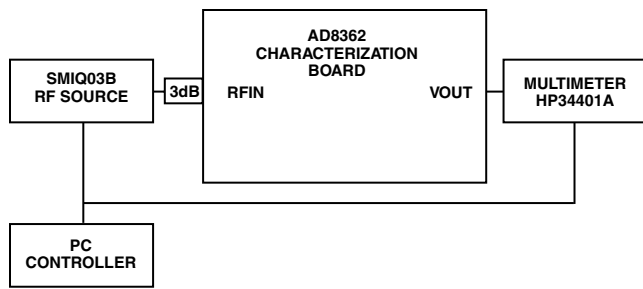

Figure 1. Primary Characterization Setup

Analysis

The slope and intercept are derived using the coefficients of a linear regression performed on data collected in its central operating range. Error is stated in two forms: error from linear response to CW waveform, and output delta from 25°C performance.

The error from linear response to CW waveform is the decibel difference in output from the ideal output defined by the conversion gain and output reference. This is a measure of the linearity of the device response to both CW and modulated waveforms. The error in dB is calculated by subtracting the ideal voltage, i.e., slope times the input level plus the intercept, from the actual input level and dividing this quantity by the slope. Error from linear response to CW waveform is not a measure of absolute accuracy, since it is calculated using the slope and intercept of each device. However, it verifies the linearity and effect of modulation on the device response. Error from 25°C performance uses the performance of a given device and waveform type as the reference; it is predominantly a measure of output variation with temperature.

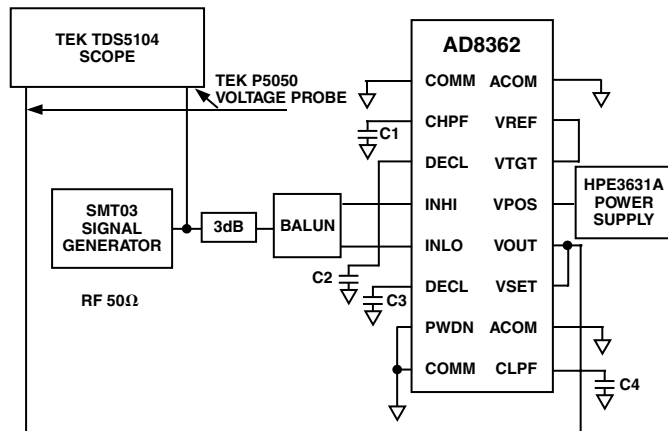

Figure 2. Response Measurement Setup for Modulated Pulse

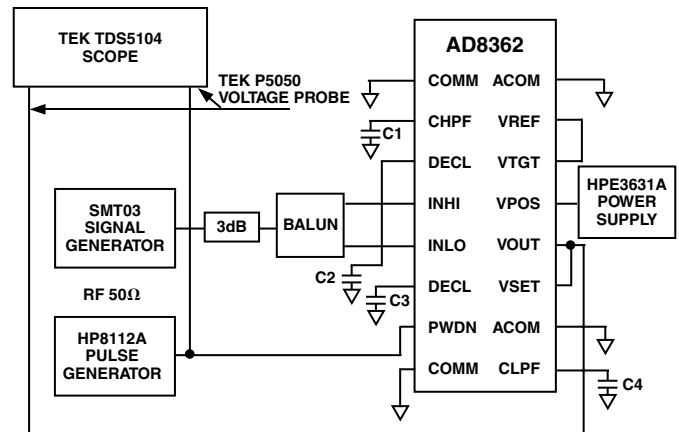

Figure 3. Response Measurement Setup for Power-Down Step

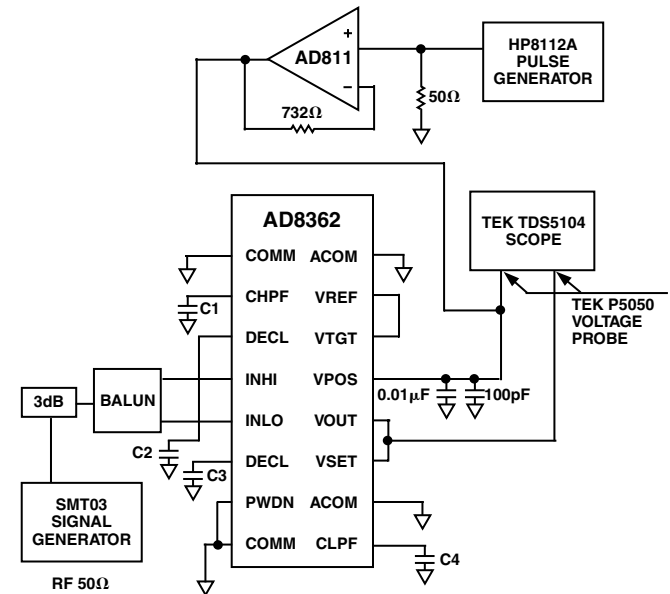

Figure 4. Response Measurement Setup for Gated Supply

CIRCUIT DESCRIPTION

The AD8362 is a fully calibrated, high accuracy, rms-to-dc converter providing a measurement range of over 60 dB and capable of operation from signals as low in frequency as a few Hertz to at least 2.7 GHz. Unlike earlier rms-to-dc converters, the response bandwidth is completely independent of the signal magnitude. The -3 dB point occurs at about 3.5 GHz. The capacity of this part to accurately measure waveforms having a high peak-to-rms ratio (crest factor) is independent of either the signal frequency or its absolute magnitude, over a wide range of conditions.

This unique combination allows the AD8362 be to be used with equal ease as a calibrated RF wattmeter covering a power ratio of $>1,000,000:1$, as a power controller in closed-loop systems, or as a general-purpose rms-responding voltmeter, and in many other low frequency applications.

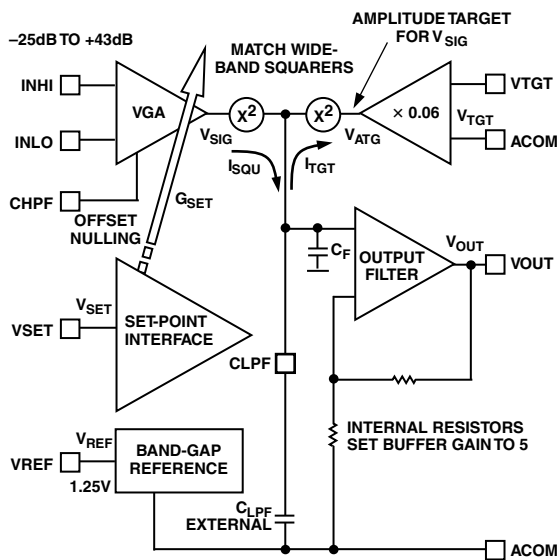

Figure 5. Basic Structure of the AD8362

It is essentially the core elements of a high performance AGC loop (Figure 5), laser-trimmed during manufacture to close tolerances while fully operational at a test frequency of 100 MHz. Its linear, wideband, variable gain amplifier (VGA) provides a general voltage gain, G_{SET} ; this may be controlled in a precisely exponential (linear-in-dB) manner over the full 68 dB range from -25 dB to $+43$ dB by a voltage V_{SET} . However, to provide adequate guard-banding, only the central 60 dB of this range, from -21 dB to $+39$ dB is normally used. Later, it will be shown how this basic range may be shifted either up or down, and even extended to >80 dB. The VGA gain has the form

$$G_{SET} = G_O \exp(-V_{SET}/V_{GNS}) \quad (1)$$

where G_O is a basic fixed gain and V_{GNS} is a scaling voltage that defines the gain slope (the “dB-change-per-volt”). Note that the gain decreases with V_{SET} . The VGA output is

$$V_{SIG} = G_{SET}V_{IN} = G_OV_{IN} \exp(V_{SET}/V_{GNS}) \quad (2)$$

where V_{IN} is the ac voltage applied to the input terminals of the AD8362.

As will later be explained more fully, the input drive may be either single-sided or differential, but optimum performance at

high frequencies will be realized only when using a differential input drive. The effect of HF imbalances when using a single-sided drive is less apparent at low frequencies (say, from 50 Hz to 500 MHz), but the peak input voltage capacity is always halved relative to differential operation (see USING THE AD8362).

Square-Law Detection

The output of the variable-gain amplifier, V_{SIG} , is applied to a wideband square law detector that provides a true-rms response to this alternating signal that is essentially independent of waveform up to crest-factors of 6. Its output is a fluctuating current, I_{SQU} , having a positive mean value. This current is integrated by an on-chip capacitance, C_F ; this will usually be augmented by an external capacitance, $CLPF$, to extend the averaging time. The resulting voltage is buffered by a gain-of-5 dc-coupled amplifier, whose rail-to-rail output, V_{OUT} , may be used either for measurement or control purposes.

In most applications, the AGC loop is closed via the set-point interface pin, V_{SET} , to which the VGA gain-control voltage V_{SET} is applied. In measurement modes, the closure is direct and local, by a simple connection from the output Pin V_{OUT} to V_{SET} . In controller modes, the feedback path is around some larger system, but the operation is basically the same.

The fluctuating current I_{SQU} is balanced against a fixed set-point target current, I_{TGT} , using current mode subtraction. With the exact integration provided by the capacitor(s), the AGC loop equilibrates when

$$MEAN(I_{SQU}) = I_{TGT} \quad (3)$$

The current I_{TGT} is provided by a second “reference” squaring cell, whose input is the amplitude-target voltage V_{ATG} . This is a fraction of the voltage V_{TGT} applied to a special interface that accepts this input at pin $VTGT$. Since the two squaring cells are electrically identical, and are carefully implemented in the IC, process and temperature-dependent variations in the detailed behavior of the two square-law functions cancel.

Accordingly, V_{TGT} (and its fractional part V_{ATG}) determines the output that must be provided by the VGA in order for the AGC loop to settle. Since the scaling parameters of the two squarers are accurately matched, it follows that Equation 3 will only be satisfied when

$$MEAN(V_{SIG}^2) = V_{ATG}^2 \quad (4)$$

In a formal solution, one would then extract the square-root of both sides to provide an explicit value for the root-mean-square (rms) value. However, it is apparent that by forcing this identity, through varying the VGA gain, and extracting the mean value by the filter provided by the capacitor(s) the system inherently establishes the relationship

$$rms(V_{SIG}) = V_{ATG} \quad (5)$$

Substituting the value of V_{SIG} from Equation 2, we have

$$rms[G_OV_{IN} \exp(-V_{SET}/V_{GNS})] = V_{ATG} \quad (6)$$

As a measurement device, V_{IN} is the unknown quantity and all other parameters can be fixed by design. Solving (6):

$$rms[G_OV_{IN}/V_{ATG}] = \exp(V_{SET}/V_{GNS}) \quad (7)$$

so

$$V_{SET} = V_{GNS} \log[rms(V_{IN})/V_Z] \quad (8)$$

AD8362

The quantity $V_Z = V_{ATG}/G_O$ is defined as the intercept voltage, since V_{SET} must be zero when rms (V_{IN}) = V_Z .

When connected as a measurement device, the output of the buffer is tied directly to VSET, which closes the AGC loop. Making the substitution $V_{OUT} = V_{SET}$, and changing the log base to ten, as needed in a decibel conversion, we have

$$V_{OUT} = V_{SLP} \log_{10} [rms(V_{IN}) / V_Z] \quad (9)$$

where V_{SLP} is the slope voltage, that is, the change in output voltage for each decade of change in the input amplitude. (Note in passing that $V_{SLP} = V_{GNS} \log(10) = 2.303 V_{GNS}$). In the AD8362, V_{SLP} is laser-trimmed to 1 V using a 100 MHz test signal. Since a decade corresponds to 20 dB, this slope may also be stated as 50 mV/dB. It is later shown how the effective value of V_{SLP} may be altered by the user.

Likewise, the intercept V_Z is also laser-trimmed to 316 μ V (–70 dBV). In an ideal system V_{OUT} would cross zero for an rms input of that value. In a single-supply realization of the function, V_{OUT} cannot run fully down to ground; here, V_Z is the extrapolated value. In measurement modes the output ranges from 0.5 V for $V_{IN} = 1$ mV (inputs are stated as rms values, outputs as dc values), up to a voltage 60 dB \times 50 mV/dB = 3 V above this for $V_{IN} = 1$ V, that is, to 3.5 V. Figure 6 shows the ideal form of Equation 9 scaled as in the AD8362.

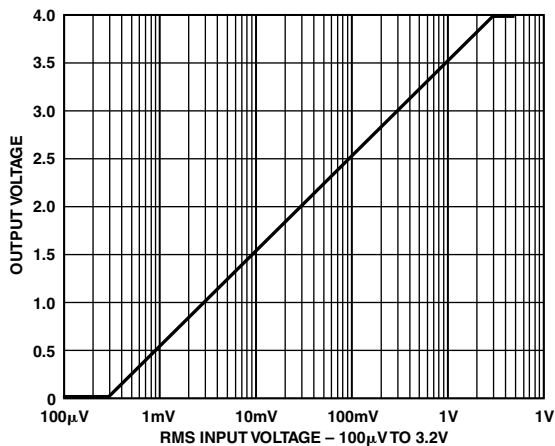

Figure 6. Ideal Response of the AD8362

Effect of Input Coupling on the Intercept Value

Reductions of V_{IN} due to coupling losses directly affect V_Z . In high frequency applications several factors contribute to the coupling of the source into the IC, including the board and package resonances and attenuation. Any uncertainties in the input impedance will result in the intercept expressed in power terms, which is nominally –57 dBm for a 50 Ω system, being less accurately determined than when stated in dBV (that is, in pure voltage) terms. On the other hand, the slope V_{SLP} is unaffected by all such impedance or coupling uncertainties.

Offset Elimination

To address the small dc offsets that arise in the variable-gain amplifier, an offset-nulling loop is used. The high-pass corner frequency of this loop is internally preset to 1 MHz, sufficiently low for most HF applications. When using the AD8362 in LF applications, it can be reduced as needed by the addition of a capacitor from Pin CHPF to ground having a nominal value of 200 μ F/Hz. For example, to lower the high-pass corner

frequency to 150 Hz, a capacitance of 0.33 μ F is required. The offset voltage varies depending on the actual gain at which the VGA is operating, and thus, on the input signal amplitude.

Baseline variations of this sort are a common aspect of all VGAs, although more evident in the AD8362 because of the method of its implementation, which causes the offsets to ripple along the gain axis with a period of 6.33 dB. When an excessively large value of C_{HPF} is used, the offset correction process may lag the more rapid changes in the VGA's gain, which may increase the time required for the loop to fully settle for a given steady input amplitude.

Voltage versus Power Calibration

The AD8362 can be used as an accurate rms voltmeter from arbitrarily low frequencies to microwave frequencies. For low frequency operation, the input is usually specified either in volts rms, or in dBV (decibels relative to 1 V rms). Driven differentially, the specified input range in dBV runs from –60 dBV to 0 dBV (1 mV to 1 V rms). In these terms, the intercept is at –70 dBV.

At high frequencies, signal levels are commonly specified in power terms. In these circumstances, the source and termination impedances are an essential part of the overall scaling. To set the AD8362's input impedance to 50 Ω , it is necessary to add a resistor of 66.7 Ω across the internal 200 Ω differential input impedance of the IC. (This is discussed further in later sections). For this condition, the intercept occurs at a nominal power level of –57 dBm, and V_{OUT} can be stated in this way:

$$V_{OUT} = (P_{IN} + 57) \times 50 \text{ mV} / \text{dB} \quad (10)$$

where P_{IN} is expressed in dBm. For example, an input of –30 dBm will generate an output of 1.35 V.

Effect of Signal Waveform

The measurement accuracy of an rms-responding device is ideally unaffected by the waveform of the input signal. This is a valuable asset in wideband CDMA systems, and in many other modulation modes, where there is a significant amount of random variation of the RF carrier amplitude at baseband frequencies. The high accuracy of the AD8362 in such cases is indicated by the Performance Curves and in the Specifications pages. Note that at low frequencies, it is customary to provide a specification of measurement errors due to waveform effects as a function of the crest factor, σ , rather than in terms of a system-specific modulation mode.

When measuring signals whose waveforms have high but brief peak values (that is, having high crest factors), these peaks may be clipped, causing a reduction in the apparent value of the input being measured. This issue is discussed further in connection with the detailed description of the input system.

Operation at Low Frequencies

In conventional rms-to-dc converters, based on junction techniques, the effective signal bandwidth is proportional to the signal amplitude. For a '1 MHz' rms-to-dc converter, this is the full-scale bandwidth. However, at an input 60 dB below full-scale, the bandwidth could be as low as 1 kHz. In sharp contrast, the 3.5 GHz bandwidth of the VGA in the AD8362 is independent of its gain; and since this amplifier is internally dc-coupled, the system can also be used as a high accuracy rms voltmeter at low frequencies, retaining its temperature-stable decibel-scaled output, for example, in seismic, audio, and sonar instrumentation.

In such cases, the input coupling capacitors should be large enough that the lowest frequency components of the signal which are to be included in the measurement are minimally attenuated. For example, for a 3 dB reduction at 1.5 kHz, capacitances of 1 μF are needed, since the input resistance is 100 Ω at each input pin, (200 Ω differentially), and we calculate $1/(2\pi \times 1.5 \text{ k}\Omega \times 100) = 1 \mu\text{F}$. Also, to lower the high pass corner frequency of the VGA, a capacitor of value 200 μF -Hz should be used between the Pin CHPF and ground; to provide a similar 1.5 kHz high-pass corner, a capacitor of 33 nF should be used.

Time-Domain Response of the Closed Loop

The external low-pass averaging capacitance, C_{LPF} , added at the output of the squaring cell, will be chosen to provide adequate filtering of the fluctuating detected signal. The optimum value depends on the application; as a guideline a value of roughly 900 nF-Hz should be used. For example, a capacitance of 5 μF will provide adequate filtering down to 180 Hz. Note that the fluctuation in the quasi-dc output of a squaring cell operating on a sine wave input is a raised-cosine at twice the signal frequency, easing this filtering function.

In the standard connections for the measurement mode, Pin VSET is tied to VOUT. For small changes in input amplitude (a few decibels), the time-domain response of this loop will be essentially linear, with a 3 dB low-pass corner frequency of nominally $f_{\text{LP}} = 1/(C_{\text{LPF}} \times 1.1 \text{ k}\Omega)$. Internal time delays around this local loop set the minimum recommended value of this capacitor to about 300 pF, giving $f_{\text{LP}} = 3 \text{ MHz}$.

When large and abrupt changes of input amplitude occur, the loop response becomes nonlinear and exhibits slew rate limitations. Further, due to the fundamentals of a system using transconductance squaring cells, as employed in the AD8362, the slewing is asymmetric for increasing and decreasing inputs. Figure 7 shows typical waveforms for VOUT for three values of V_{IN} , using $C_{\text{LPF}} = 1 \text{ nF}$.

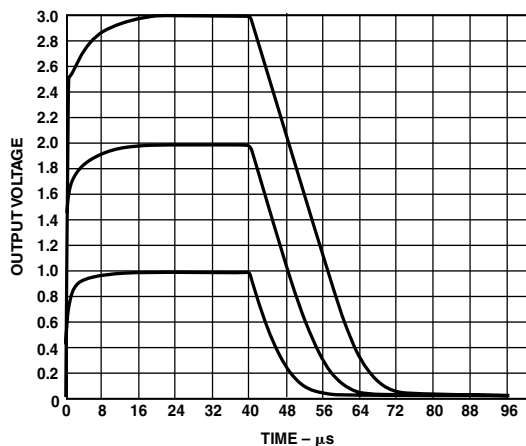

Figure 7. Typical Large-Signal Response

The most satisfactory way to quantify slew-rate limitations is by considering the peak currents that can be generated by the squaring cells. During a fast increase in input level, the peak current into the integrating (loop filter) capacitance, C_{LPF} , is approximately 2.5 mA. The actual value depends on several factors, including the size of the step, and extremes in chip temperature. The voltage across the 1 nF capacitor will thus increase at a rate of nominally 2.5 V/ μs . Since the output buffer has a gain of 5, the output slew rate will be 12.5 V/ μs . The peak rate persists up to a point about 10 dB below the final value, after which the response gradually converges on the linear-system response, as noted above.

On the other hand, during a fast decrease in input level, the peak current in C_{LPF} in the opposite (discharging) direction is much smaller: it is roughly 25 μA . Thus, the slew rate for V_{OUT} in the descending direction is only about 0.125 V/ μs for $C_{\text{LPF}} = 1 \text{ nF}$. To discharge over the full 3 V range (a 60 dB reduction of input) requires a time interval of $\sim 24 \mu\text{s}$. These figures are verified in the results shown in Figure 7.

Alteration of the Internal Target Voltage

The AD8362 incorporates several features which extend its versatility. One of these is the ability to alter the “target” voltage. As noted, the output of the VGA is forced to a value set by the internal bias voltage ($V_{\text{STP}} = 0.06 \times V_{\text{TGT}}$) applied to the reference squaring cell. It is normally set to 75 mV dc, by connecting VTGT to the 1.25 V reference voltage at Pin VREF. However, it may optionally be varied from 0 V up to $\pm 0.24 \text{ V}$ ($\pm 4 \text{ V}$ at VTGT). Note that the sign of this input is unimportant, since it is internally squared.

By lowering V_{SPT} , the output of the VGA needed to balance the output currents of the two matched squaring cells will be similarly lowered. This reduces the intercept in precisely the same ratio. Thus, if we halve the set-point target voltage by halving the voltage applied to Pin VTGT, the intercept moves to the left (to a smaller input level) by 6.02 dB. This effectively doubles the measurement system’s sensitivity.

Furthermore, because the signal amplitude needed to drive the squaring cell is halved, the output stage of the VGA now has twice the dynamic headroom (before clipping), and can handle waveforms having crest-factors that are twice as large. Figure 8 shows the overall response for an illustrative set of values of $V_{\text{TGT}} = 0.3 \text{ V}, 0.533 \text{ V}, 0.949 \text{ V}, 1.687 \text{ V},$ and 3.0 V . While this will usually be a fixed dc voltage, it can also be a time-varying, unipolar or bipolar voltage, in which case the overall operation is rather more complex. For example, when V_{TGT} is derived from V_{OUT} the dynamic range can be extended to over 80 dB. Examples of such uses of this feature are presented later.

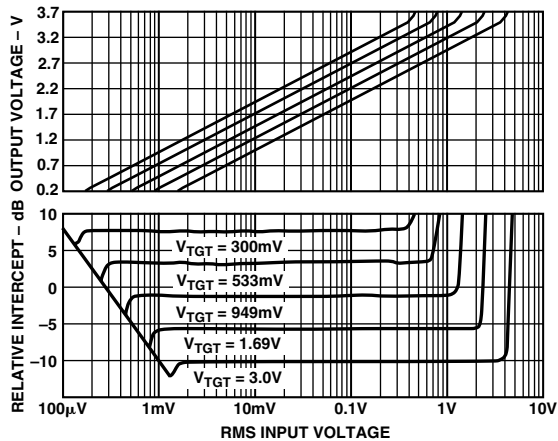

Figure 8. Response with V_{TGT} Varied from 0.3 V to 3 V in 5 dB Steps, Showing the Proportional Shift in Intercept

Effects at Each End of Dynamic Range

All AGC loops have a limited minimum and maximum input beyond which the system cannot respond correctly. However, the output of a well-behaved system will be in error in such a way as to avoid anomalous measurements. For an input below its minimum capability, the output should not “turn around,” to falsely indicate a higher input value; for inputs above its maximum capability, the output should not “fold over,” and return to some lower value.

The actual behavior of the AD8362 under these conditions can be seen in the set of plots in Figure 8, the lower panel of which shows the deviation from the ideal response with a slope of 50 mV/dB. For inputs below a certain level, corresponding to the point at which the VGA is operating at its maximum gain, its output can no longer meet the rms amplitude target set by V_{TGT} , so the output moves quickly to its minimum value, in an attempt to provide the needed extra gain. As V_{TGT} is altered, the corresponding end-limit voltage moves to the left or right.

On the other hand, when the input is above a certain upper limit, where the VGA gain has been driven to its minimum gain, any further increase will drive its output well above the target voltage needed to balance the loop, and the resulting integration of this internal error signal causes V_{OUT} to rise abruptly. In either case, this output takes on a safe value, and does not fold back under any conditions.

The dynamic range, the “dB distance” between these limits, is not basically dependent on V_{TGT} . The middle line in the plots of Figure 8 ($V_{TGT} = 0.949$ V), extends from 0.5 mV to 1.5 V between the $\pm 1\%$ error points; the dynamic range is thus slightly over 68 dB. For other values of V_{TGT} , this basic 68 dB range just moves to the left or the right.

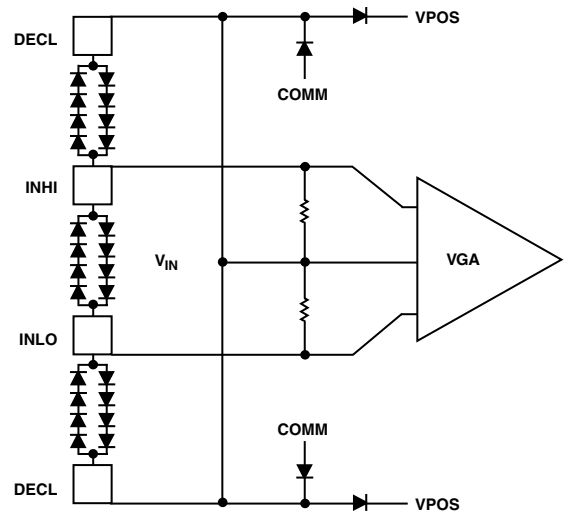

Figure 9. Input Protection at INHI and INLO Pins

Input Protection

Like all robust ICs, the AD8362 requires input protection against high voltage transients at the input (ESD), but the techniques normally employed for this purpose, based on breakdown diodes from the input Pins INHI and INLO to the supply Pins VPOS and COMM cannot be used here, since this raises the risk of excessive signal coupling to internal nodes at the upper end of the frequency range, due to feedthrough in the capacitances of these diodes. Package inductances cause all internal nodes, including the supply and common lines, to have a significant impedance back to the external ground plane; even small disturbances on these nodes can cause anomalous operation.

This risk is particularly evident since the main amplifier in the AD8362's VGA (an advanced X-AMP[®]) operates at full gain under all conditions, while the signal input is variably attenuated. Since this attenuation may be as high as 70 dB, very small feedthrough effects in the 0.5 GHz–3 GHz range can have a pronounced impact on measurement accuracy.

Figure 9 shows the protection method used. The multiple diodes arranged in back-to-back pairs limit the voltage swing on the input pins by clamping to the two DECL pins, which form a common ac low impedance node for the attenuators, independently grounded via two external capacitors. The HF currents in the capacitances of these diodes are thus shunted directly to a signal null-point.

An unavoidable consequence of this method is that the diodes will forward-conduct when the input amplitude is sufficient. This is not an all-or-nothing effect, of course; they shunt the input progressively as the signal increases. This conduction will be strongest at high temperatures, when the forward drop voltage of these diodes is lowest. The overall consequence is that high

amplitude peaks will be clamped, to a greater or lesser degree. This will affect the measurement accuracy at the top extreme of the dynamic range whenever the signal waveform has a high crest factor. These effects are, of course, included in the overall performance specifications.

Power-Enable Response Time

The operating and stand-by currents for the AD8362 at 27°C are 24 mA and 275 μ A, respectively; their variations versus temperature are shown in TPC 31. The power-down mode is activated by a logic HI on Pin PWDN. When the shut-down feature is used, the normal operating conditions are restored relatively quickly when this pin is taken LO.

Figure 10 shows typical response times for a midscale signal ($V_{IN} = 50$ mV). The output rises to within 0.1 dB of its steady-state value in about 20 μ s; the reference voltage is available to full accuracy in a much shorter time. This “wake-up” response will vary in detail depending on the input coupling means and the capacitances C_{DEC} , C_{HPF} , and C_{LPF} . These results are for a measurement system operating in the 0.8 GHz to 2 GHz range, balun-coupled at the input port, with $C_{DEC} = 1$ nF, $C_{HPF} = 0$, and $C_{LPF} = 1$ nF.

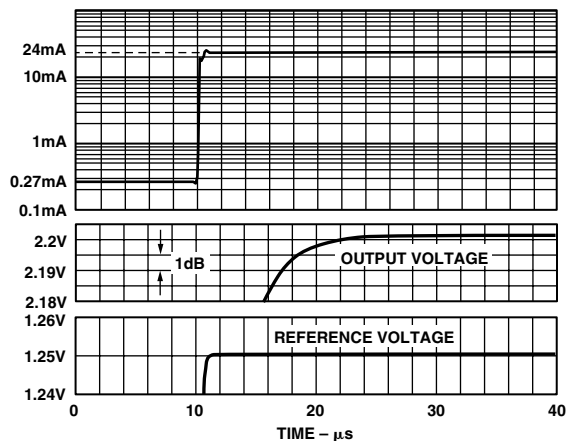

Figure 10. Typical “Wake-up” Response; $t_0 = 10$ μ s

USING THE AD8362

The AD8362 requires a single supply of nominally 5 V; its performance is essentially unaffected by variations of up to $\pm 10\%$, the range over which the stated specifications apply. Supplies as low as 2.7 V may be used with some loss of performance at high inputs and at temperature extremes.

The AD8362 is disabled by a logic HI on the PWDN pin, which may be directly grounded for continuous operation, when the supply current at 27°C is nominally 24 mA and essentially independent of supply voltage. When powered down by a LO on PWDN, the supply current is reduced to about 275 μ A.

Basic Connections

The supply is connected to Pin VPOS, using the decoupling network shown in Figure 11, whose capacitors must provide a low impedance over the full frequency range of the input, and should be placed as close as possible to the VPOS pin. Two different capacitors are used in parallel to reduce the overall impedance, since these will have different resonant frequencies. However, the measurement accuracy is not critically dependent on supply decoupling, since the high frequency signal path is

confined to the relevant input pins. It is more important that the lead lengths to INHI and INLO, and in the decoupling capacitors from both of the DECL pins to ground, and the connections from COMM to the ground plane all use the shortest possible connections.

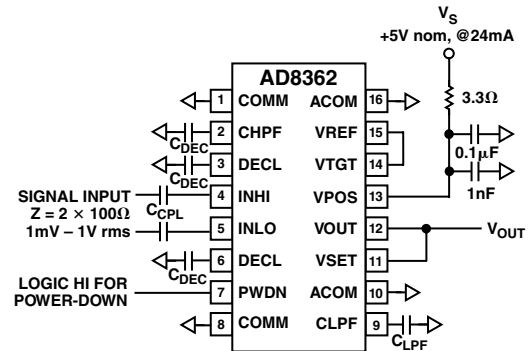

Figure 11. Basic Measurement Mode Connections

MAIN MODES OF OPERATION

Both measurement and controller modes are supported by the AD8362. Typical connections for the Measurement mode, which may also be viewed as the “RMS Voltmeter” mode, are also illustrated in Figure 11. The output, V_{OUT} , is proportional to the logarithm of the rms magnitude of the input signal (that is, a “linear-on-dB” response). When used in an accurately known system impedance (but only then), the output is a scaled decibel measurement of the power represented by the input voltage.

The choice of the capacitances C_{CPL} , C_{DEC} , C_{HPF} , and C_{LPF} , will depend on the lowest frequency to be included in the measurement spectrum. The default values shown support operation down to 100 Hz. Using a large enough value of C_{LPF} (10 μ F) to ensure sufficient filtering at this low input frequency, the response time is approximately 20 ms over most of the dynamic range. In high frequency applications, this capacitor will be much smaller, and will usually be chosen to minimize the response-time, consistent with well-behaved large-signal behavior. In this figure, C_{HPF} is also shown as 10 μ F, to lower the high-pass corner to about 90 Hz. However, no capacitor will be needed here in most HF applications, since the internally-set high-pass corner is at about 2 MHz.

Now briefly comparing the controller mode, illustrated in Figure 12, the AD8362 is here used to monitor the output of a variable-gain (or variable output power) signal processing element, frequently a power amplifier, and adjust its output to a desired target value (the set-point), under the control of VSET. In this mode, its function is somewhat like an RF comparator. With the path from V_{OUT} to VSET broken, any input larger than the corresponding set-point causes V_{OUT} to rail to its maximum value (which might loosely be viewed as a logic HI). For inputs smaller than the set-point, the controller’s output will fall to a near-ground level (logic LO). Using the AD8362 simply as a threshold detector, this viewpoint may be useful, but in most applications it is an oversimplification. The AD8362 will invariably operate with the control loop closed, either locally, with V_{OUT} connected to VSET (as in measurement mode), or globally, via some external nonlinear element (as in controller mode).

AD8362

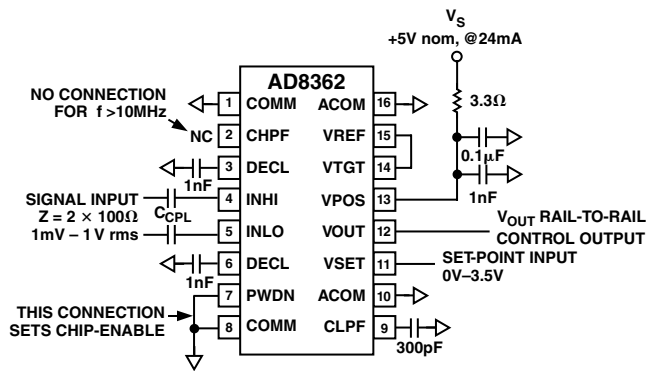

Figure 12. Basic Controller Mode Connections

Controller mode operation is more closely analogous to that of a classical proportional/integral/derivative (PID) loop. The error corresponding to the decibel deviation from the set-point is integrated, by current into a capacitor (the sum of the internal and external capacitance C_{LPF}), until such deviation is nulled. This action provides the fundamental proportional part of the loop response (although V_{OUT} has decibel scaling). The Q of this system can be adjusted to minimize the loop response time by including a resistor in series with C_{LPF} , generating a transmission zero, which provides the derivative term of a standard PID loop.

As a simple example, assume that the AD8362 operates at an input power level of -20 dBm re: 50Ω . Connected in the Measurement mode it will generate a V_{OUT} of 2.00 V (since this input is 40 dB above the intercept at -60 dBm, and is scaled 50 mV/dB. Rearranged to the controller mode, with exactly this voltage now externally applied to Pin VSET, the loop forces V_{OUT} to the control voltage required by the gain element to provide a power sample of -20 dBm.

Of course, any control loop of this sort will only operate correctly if VSET corresponds to a power level (or a small sample of such) than can actually be provided by the external gain element. When this is a power amplifier, the inclusion of the required amount of RF attenuation ensures this condition. In certain instrumentation situations, it may be necessary to provide some low noise gain ahead of the AD8362's input.

These two primary modes of use of are now discussed in more detail, with emphasis on practical considerations.

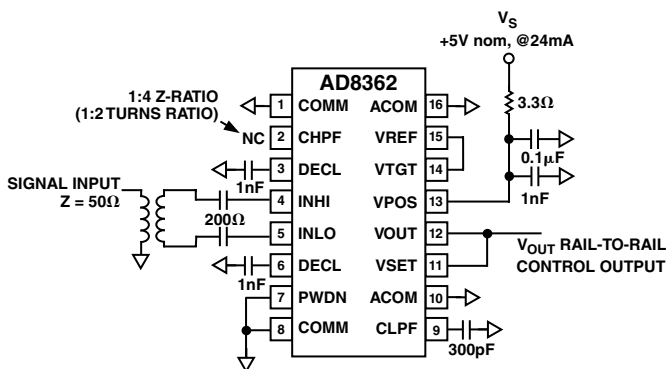

Figure 13. Connections for RF Power Measurement

OPERATION IN MEASUREMENT MODES

Figure 13 shows the general connections for operating the AD8362 as an RF power detector, more correctly viewed as an accurate measurement system. The full performance potential of this part, particularly at very high frequencies (above 500 MHz) will only be realized when the input is presented to the AD8362 in differential (balanced) form. In this illustrative example, a flux-coupled transformer is used at the input. Having a $1:4$ impedance ratio, ($1:2$ turns ratio) the 200Ω differential input resistance of the AD8362 becomes 50Ω at the input to the transformer, whose outputs can be connected directly to INHI and INLO. If a center-tapped transformer is used, connect the tap to the DECL pins, which are biased to the same potential as the inputs (~ 3.6 V). Over the 0.9 GHz– 2.2 GHz range a transmission line transformer (“balun”) may be used, as explained later. (The evaluation board is supplied with a M/A-COM ETC1.6-4-2-3, 0.5 GHz– 2.5 GHz, $4:1$ balun).

The output in this mode of use is a continuous, decibel-scaled voltage:

$$V_{OUT} = (P_{IN} P_Z) \times 50 \text{ mV/dB} \quad (11)$$

ranging from about 0.5 V to 3.5 V. The equivalent input power P_{IN} is expressed in dBm, (decibels above 1 mW) in a particular system impedance, which in this case is 50Ω . The intercept, P_Z , is that input power for which the back-extrapolated output crosses zero. Expressed as a voltage it is 0.447 mV rms (-67 dBV, laser-calibrated at 100 MHz), corresponding to a P_Z of -60 dBm in 200Ω . However, the $1:2$ turns ratio of the transformer halves the required input voltage, which moves the intercept down by 6 dB, to 0.224 mV rms (-73 dBV) at the transformer's input.

Impedance mismatches and attenuation in the coupling elements will significantly affect the intercept position. This error will be stable over temperature and time, and thus can be removed during calibration in a specific system. The logarithmic slope of 50 mV/dB varies only slightly with frequency; corrected values for several common frequencies are provided in the Specifications.

Law Conformance Error

In practice, the response will deviate slightly from the ideal straight line suggested by Equation 11. This deviation is called the “law conformance error.” In defining the performance of high accuracy measurement devices, it is customary to provide plots of this error. In general terms, it is computed by extracting the best straight line to the measured data using linear regression over a substantial region of the dynamic range, and under clearly specified conditions.

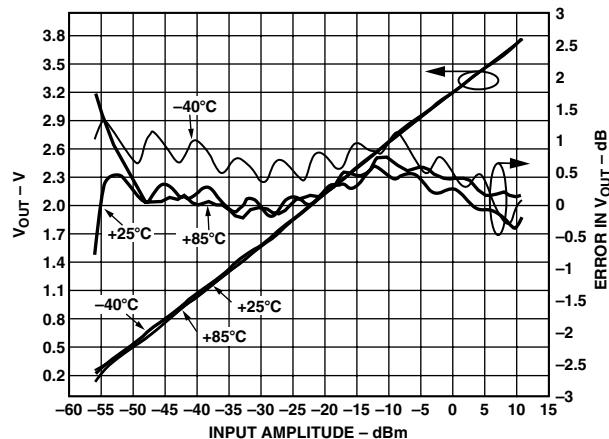

Figure 14. Output Voltage and Law Conformance Error, at $T_A = -40^\circ\text{C}$, $+25^\circ\text{C}$ and $+85^\circ\text{C}$

Figure 14 shows the output of the circuit of Figure 13 over the full input range. The agreement with the ideal function (law conformance) is also shown. This was determined by linear regression on the data points over the central portion of the transfer function (35 mV to 250 mV rms) for the 25°C data. The error at $+25^\circ\text{C}$, -40°C , and $+85^\circ\text{C}$ was then calculated by subtracting the ideal output voltage at each input signal level from the actual output, and dividing this quantity by the mean slope of the regression equation to provide a measurement of the error in decibels (scaled on the right-hand axis of Figure 14).

The error curves generated in this way reveal not only the deviations from the ideal transfer function at a nominal temperature, but also all of the additional errors caused by temperature changes. Notice there is a small temperature-dependence in the intercept (the vertical position of the error plots); this variation is within 0.5 dB at high powers.

Figure 14 further reveals that there is a periodic ripple in the conformance curves. This is due to the interpolation technique used to select the signals from the attenuator, not only at discrete tap points, but anywhere in between, thus providing continuous attenuation values. The selected signal is then applied to the 3.5 GHz, 40 dB fixed gain amplifier in the remaining stages of the AD8362's VGA.

An approximate schematic of the signal input section of the AD8362 is shown in Figure 15. The ladder attenuator is composed of a eleven sections (twelve taps), each of which progressively attenuates the input signal by 6.33 dB. Each tap is connected to a variable-transconductance cell, whose bias current determines the signal weighting given to that tap. The interpolator determines which stages are active, by generating a discrete set of bias currents, each having a Gaussian profile. These are arranged to move from left to right, thereby determining the attenuation applied to the input signal, as the gain is progressively lowered over the 69.3 dB range under control of the V_{SET} input. The detailed manner in which the transconductance of adjacent stages varies, as the "virtual tap point" slides along the attenuator, accounts for the ripple observed in the conformance curves. Its magnitude is slightly temperature-dependent, and also varies with frequency (see TPCs 3–5). Notice that the system's responses to signal inputs at INHI and INLO are not completely independent: these pins do not constitute a fully floating differential input.

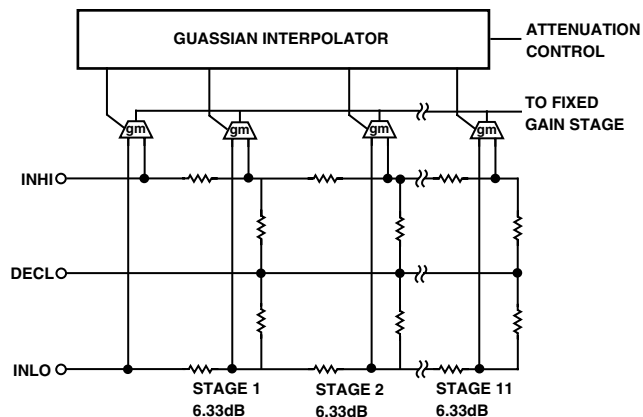

Figure 15. Simplified Input Circuit

Alternative Input Coupling Means

The input stages of the AD8362 are optimally driven from a fully-balanced source, which should be provided wherever possible. The ac low side of both halves of the attenuator internally connect to the DECL pin, which is therefore the RF signal low terminal for both INHI and INLO. In many cases, unbalanced sources can be applied directly to one or the other of these two pins. The chief disadvantage of this driving method is a reduction in dynamic range, particularly at very high frequencies.

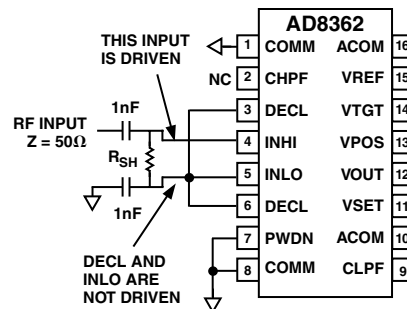

Figure 16. Input Coupling from a Single-Ended Source

Figure 16 illustrates one of many ways of coupling the signal source to the AD8362. Since the input pins are biased to about 3.6 V (for $V_S = 5\text{ V}$) dc-blocking capacitors are required when driving from a grounded source. For signal frequencies $>5\text{ MHz}$, a value of 1 nF is adequate. While either INHI or INLO may be used, the former is chosen here, and INLO is connected to the low side of the source. The resistor R_{SH} is not needed if a $100\ \Omega$ termination is acceptable. The corresponding intercept will still be -67 dBV , that is, $447\ \mu\text{V rms}$. However, specified in power terms re: $100\ \Omega$, the P_Z is now at 2 nW, or -57 dBm .

For a source termination of $50\ \Omega$, the internal $100\ \Omega$ from INHI to DECL must be shunted by a chip resistor of $100\ \Omega$. At high frequencies, a low attenuation pad at the input will improve the VSWR. For example, with a resistor of $R_{\text{SH}} = 33\ \Omega$ and an added resistor of $25\ \Omega$ from the source to INHI, a termination of $50\ \Omega$ is provided, with 6 dB of attenuation, raising the intercept to -48 dBm .

Use of a Narrow-Band Input Match

While transformers offer the simplest method for providing single-sided to balanced conversion, a good alternative is the use of a specially designed narrow-band LC network, shown in

AD8362

Figure 17, which also provides an input match. Using this basic formulation, the match is to 50 Ω, with a voltage gain of 1.5 (3.56 dB) from the input connector to the AD8362. This network is specially designed to provide a high degree of amplitude balance at INHI and INLO, as well as an exact phase inversion. The narrow-band match provides a useful degree of frequency selectivity, and the capacitors also serve to provide the required dc blocking.

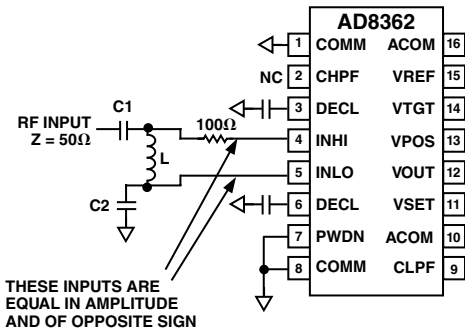

Figure 17. Narrow Band Reactive Input Coupling

The network can readily be scaled to other frequencies by varying the product LC, while keeping the ratio L/C constant to preserve a 50 Ω input impedance. Table I provides some spot values; these take into account the reactive Z_{IN} of the AD8362.

Table I. Suggested Components for Narrow-Band 50 Ω Match

Frequency (MHz)	L (nH)	C1 (pF)	C2 (pF)
1	21850	2230	2765
2	10925	1115	1383
5	4370	446	553
10	2185	223	276
20	1093	112	138
50	437	45	55
100	220	22	27
200	100	10	12
500	40	3.9	4.7

This coupling method can be used down to much lower frequencies than shown in Table I, simply by multiplying the 1 MHz component values proportionally. The effects of the reactive components of the AD8362's inputs above 500 MHz may require some fine-tuning of the suggested values, and in the gigahertz region the input coupling will usually be more effectively implemented using a balun.

Uncertainties in R_{IN} and Power Calibration

In all these cases where a 50 Ω to 200 Ω transformation is implemented, the voltage gain is only nominally $\times 2$ (6 dB). This ideal is impaired by the fact that the input resistances of the AD8362 are not precise: variations of $\pm 20\%$ can be expected from lot to lot. Therefore, it is necessary to use a calibration step whenever an accurate value for the power intercept, P_Z , must be established.

When driven differentially, a significant improvement in intercept accuracy can be achieved by shunting the 200 Ω resistance from INHI to INLO with a 66.5 Ω resistor, to set the differential input resistance to 50 Ω. Assuming a tolerance of $\pm 20\%$ for the basic R_{IN} and $\pm 1\%$ for the chip resistor, the net input resistance could exhibit an error of $\pm 2.5\%$. The resulting error in P_Z (and thus in the absolute power measurement) may vary from -0.26 dB to $+0.21$ dB.

These precautions regarding input impedance do not apply when the input is presented in voltage form, as will often be the case at low frequencies, or when the source impedance is low compared to 200 Ω. For example, using a feedback amplifier as an impedance buffer ahead of the input, as in the later example of Figure 24, the loss at the interface at moderate frequencies is negligible.

Choosing the Right Value of CHPF and CLPF

The AD8362's 3.5 GHz variable gain amplifier includes an offset cancellation loop, which introduces a high-pass filter effect in its transfer function. The corner frequency, f_{HP} of this filter must be below that of the lowest input signal in the desired measurement bandwidth frequency in order to properly measure the amplitude of the input signal. The required value of the external capacitor is given by

$$C_{HPF} = 200 \mu F / f_{HP} \quad (f_{HP} \text{ in Hz}) \quad (12)$$

Thus, for operation at frequencies down to 100 kHz, C_{HPF} should be 2 nF.

In the standard connections for the measurement mode, pin VSET is tied to VOUT. For small changes in input amplitude (a few decibels), the time-domain response of this loop will be essentially linear, with a 3 dB low-pass corner frequency of nominally $f_{LP} = 1 / (C_{LPF} \times 1.1 \text{ k}\Omega)$. Internal time delays around this local loop set the minimum recommended value of this capacitor to about 300 pF, giving $f_{LP} = 3$ MHz.

For operation at lower signal frequencies, or whenever the averaging time needs to be longer, use

$$C_{LPF} = 0.9 \mu F / f_{LP} \quad (f_{LP} \text{ in Hz}) \quad (13)$$

When the input signal exhibits large crest factors, such as a W-CDMA signal, it will be found that C_{LPF} must be much larger than might at first seem necessary. This is due to the presence of significant low frequency components in the complex, pseudo-random modulation, which will generate fluctuations in the output of the AD8362.

Use of Nonstandard Target Voltages

An external connection between VREF and VTGT sets up the internal target voltage, that is, the rms voltage that must be provided by the VGA in order to balance the AGC feedback loop. In the default scheme, the V_{REF} of 1.25 V positions this target to $0.06 \times 1.25 \text{ V} = 75 \text{ mV}$. In principle, however, VTGT may be driven by any voltage over the range -4 V to $+4 \text{ V}$ (the sign is ignored) to alter this target, either in a fixed or dynamic way.

For example, if this pin is supplied from VREF via a simple resistive attenuator of 1 kΩ:1 kΩ, the output required from the VGA is halved (to 37.5 mV rms), which moves the nominal intercept to -73 dBV. Under these conditions, the effective headroom in the signal path that drives the squaring cell is doubled.

In principle, this doubles the peak crest factor that may be handled by the system.

If V_{TGT} is reduced too far, the accuracy and stability of the intercept will be compromised. The currents generated by the transconductance mode squaring cells become smaller by the square of the ratio. Thus, a factor of 5 reduction in V_{TGT} will lower the signal currents in the squaring cells by a factor of 25. As well as making the system more sensitive to small static errors (offsets) in the post-detection circuitry, such a reduction will also reduce the peak slew rate, and a suitable adjustment to the value of C_{LPF} will be needed to maintain a given AGC loop bandwidth. On the other hand, increasing the target voltage can improve the accuracy and stability of the intercept for low crest factor signals. Thus, using $V_{TGT} = 2.5$ V, the peak output currents of the squaring cell are quadrupled, and the peak slew rate is increased by the same factor. $CLPF$ should be increased to maintain an adequate stability margin in the AGC loop.

In many applications, it will be useful to use a nonstandard value of V_{TGT} to shift the measurement range by a constant amount, to accommodate either a reduced or increased range of signal inputs. The dynamic span remains >60 dB for such changes. This technique will be particularly useful when the sensitivity can be lowered, by raising V_{TGT} , and there is little expectation of high crest factor signals.

Adjusting the Intercept

Another way to exploit the effect of V_{TGT} is to use it to introduce an adjustment to the log intercept, represented by the voltage V_Z in Equation 14. Formally, this can be expressed in terms of a modified value of V_Z' :

$$V_Z' = V_Z V_{TGT} / 1.25 V \quad (14)$$

A lower V_{TGT} effectively increases the sensitivity of the measurement system, which is just another way of stating that the intercept moves to a lower value. This raises V_{OUT} for all input amplitudes, as was demonstrated earlier by the plots shown in Figure 8. This control of the measurement system's intercept could therefore be effected by applying the output of a DAC to Pin $VTGT$, if that suits the overall objectives of an application.

For many purposes, a small manual adjustment range of ± 3 dB will be sufficient. This can be implemented as shown in Figure 18. Here, the largest fraction of V_{TGT} is still provided by the built-in reference, to minimize the sensitivity to supply voltage variations, but now a variable component is provided by the trim network. For a 5 V supply, this added component of V_{TGT} is zero when $VR1$ is centered. With the slider closest to ground, V_{TGT} is lowered by 366 mV, which corresponds to a 3 dB decrease in intercept; in the opposite condition, it is raised by 518 mV, which increases the intercept by 3 dB. That is, V_{TGT} ranges from $1.25 \sqrt{2}$ to $\sqrt{2} \times 1.25$ V.

Other adjustment ranges can be readily calculated from this example. The resistance at Pin $VTGT$ is nominally 52 k Ω , so resistor values should be calculated with this in mind. In some situations, this control interface might be driven from a programmable source. In the simplest case, a logic level could provide two intercept values, differing by say, 10 dB, thus providing essentially two switched input ranges.

Also, it is worth remembering that these shifts in intercept are equivalent, in most respects, to a dc offset applied to the

AD8362's output, with the main differences being that (1) varying V_{TGT} affects the crest factor capacity to some extent; (2) this technique makes better use of the available output range than a post- V_{OUT} adjustment would.

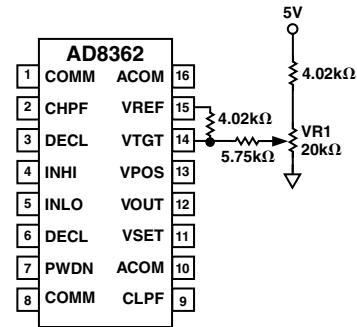

Figure 18. Adjustment of the Intercept by ± 3 dB

Altering the Slope

None of the changes in operating conditions discussed so far affect the logarithmic slope, V_{SLP} in Equation 9. However, this can readily be altered by controlling the fraction of V_{OUT} that is fed back to the set-point interface, at Pin $VSET$. When the full signal from $VOUT$ is applied to $VSET$, the slope assumes its nominal value of 50 mV/dB. It can be increased by including an attenuator between these pins, a shown in Figure 19. Moderately low resistance values should be used, to minimize scaling errors due to the 70 k Ω input resistance at the $VSET$ pin, but keep in mind that this resistor string also loads the output, and it will eventually reduce the load-driving capabilities if very low values are used. To calculate the resistor values, use

$$R1 = R2' (S_D / 50 - 1) \quad (15)$$

where S_D is the desired slope, expressed in mV per dB, and $R2'$ is the value of $R2$ in parallel with 70 k Ω . For example, using $R1 = 1.65$ k Ω and $R2 = 1.69$ k Ω ($R2' = 1.649$ k Ω), the nominal slope is increased to 100 mV/dB. This choice of scaling will be useful when the output is to be applied to a digital voltmeter, since the displayed number reads as a decibel quantity directly, with only a decimal-point shift.

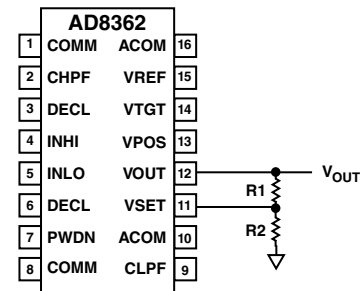

Figure 19. External Network to Raise Slope

AD8362

Operation at high slopes is useful when a particular sub-range of the input is to be measured in greater detail. However, a measurement range of 60 dB would correspond to a 6 V change in V_{OUT} at this slope, exceeding the capacity of the AD8362's output stage when operating on a 5 V supply. This requires that the intercept is repositioned to place the desired sub-range within a window corresponding to a output range of $0.2 \text{ V} \leq V_{OUT} \leq 4.8 \text{ V}$, a 46 dB range.

Using the arrangement shown in Figure 20, an output of 0.5 V corresponds to the lower end of the desired sub-range, and 4.5 V corresponds to the upper limit, with 3 dB of margin at each end of the range, which is nominally 3 mV rms to 300 mV rms, with the intercept at 1.9 mV rms. Note that R2 is connected to VREF rather than ground. R3 is needed to ensure that the AD8362's reference buffer, which can sink only a small current, is correctly loaded.

It will be apparent that a variable attenuation factor based on this scheme could provide a manual adjustment of the slope, but there will be few situations in which this will be of value. When the slope is raised by some factor, the loop capacitor C_{LFP} should be raised by the same factor to ensure stability and to preserve a chosen averaging time. The slope can be lowered by placing a two-resistor attenuator after the output pin, following standard practice.

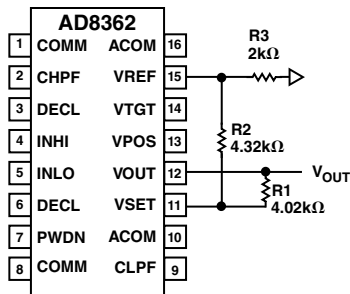

Figure 20. Scheme Providing 100 mV/dB Slope for Operation over a 3 mV to 300 mV Input Range

Envelope Elimination Mode

The VTGT input can be used to track the AM modulation envelope on an RF signal, to effect a form of envelope elimination. The modulation waveform must be known, and a sample available as a baseband voltage. Using this voltage as V_{TGT} , the AD8362 tracks this envelope when demodulation is effected by the squaring cell. So, if the envelope output of the main amplifier should, say, double over some interval, while the target voltage that satisfies the AGC loop criterion also doubles, the net effect will be that the gain of the amplifier will not need to change, in order to keep the loop balanced.

That being the case, the gain-control voltage V_{SET} likewise does not need to change. It follows that the output will be free of fluctuations. In the measurement mode, that voltage is also the output, so it also remains at a constant value as the modulation varies the input magnitude. The bandwidth of the dc-coupled amplifier in the AD8362 that buffers V_{TGT} has been kept high (~300 MHz), so that even fast AM modulation envelopes can be accurately tracked.

Figure 21 shows an illustrative realization. As depicted in the top panel of Figure 22, the input to the AD8362 is a pure, ideal, sinusoidal 100 MHz carrier that is amplitude modulated at 100 kHz by another pure sine wave. A suitably scaled sample of the modulation voltage is also applied to the VTGT pin. In this illustrative example, its average value is 1.25 V (the normal bias level for V_{TGT}) and the amplitude is 0.75 V. So V_{TGT} ranges from 0.5 V to 2 V, corresponding to a factor of 4 change (16 dB) in the target voltage over each cycle of the modulation. The resulting V_{OUT} waveform is of essentially constant value at about 2.5 V, as shown in Figure 22; this is compared with the deeply fluctuating output for a fixed V_{TGT} of 1.25 V.

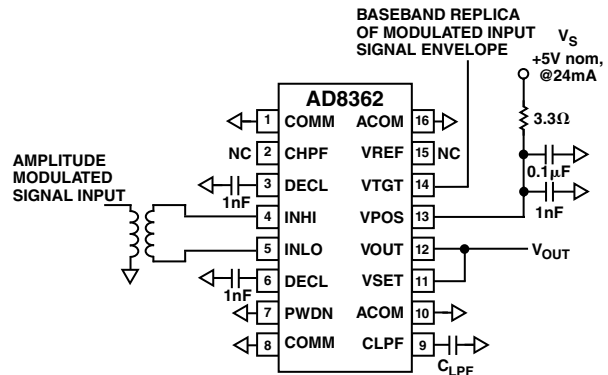

Figure 21. Envelope Elimination using the VTGT Interface

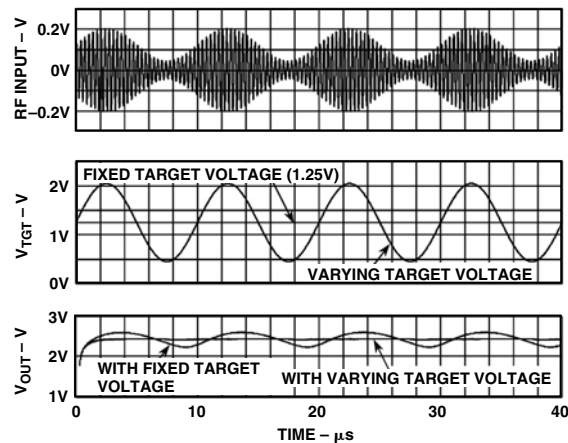

Figure 22. Waveforms for Envelope Elimination Scheme

OPERATION IN CONTROLLER MODES

In order to fully understand this section, it is important to first read the preceding discussion of measurement modes, since there are only a few differences in operation and connections.

When used in controller applications, the basic objective is to use the AD8362 as a level-sensing element, in such a way that its output, here V_{APC} , moves in a direction that increases the controlled signal when the input sample is too low, and vice versa. A general scheme is illustrated in Figure 23.

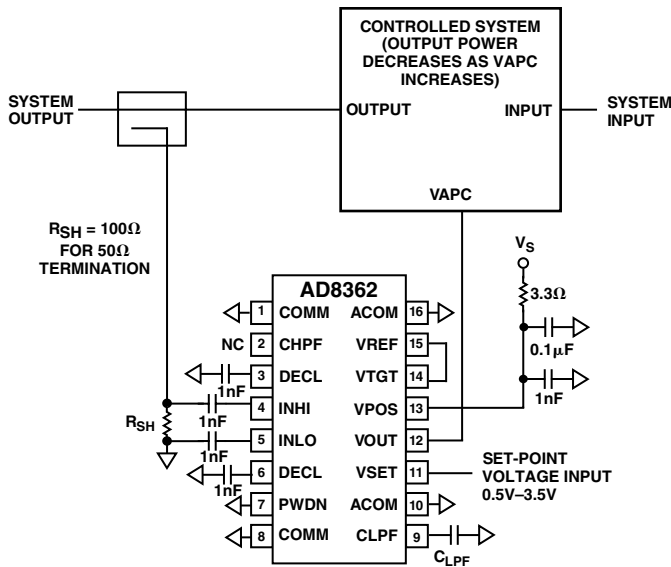

Figure 23. Generalized Control Loop Using the AD8362

Since the AD8362 integrates any input error, relative to the set-point, and ideally would fully null this error over an appropriate time interval, it follows that V_{APC} will swing rail-to-rail over a very narrow range of inputs. In practice, a few millidecibels of amplitude deviation at the input will fully swing the output.

The signal input level at which this occurs (the “set-point”) is determined by the control voltage, V_{SET} . This voltage defines the narrow range of the ac input over which the AD8362’s output is most sensitive to the absolute input magnitude. In base stations, for example, V_{SET} will often be delivered by the “ramp DAC”, and the set-point will be a rapidly varying sequence of levels, during the ramp-up and ramp-down intervals of each burst, as well as with output power demand variations from one channel to another.

Every value of V_{SET} maps uniquely to a specific rms value at its input. Thus, the major loop shown in Figure 23 forces the system being controlled, S, to deliver exactly this level (which may be either in voltage form, or as a sample of the power output of S). This mode of operation is therefore just an extension of the measurement mode, having exactly the same scaling (slope and intercept) at the VSET pin.

When the “system” in Figure 23 is an RF power amplifier (PA), a practical consideration immediately comes to our attention. Frequently, the gain (and thus output power) is arranged to increase in response to an increasing positive voltage applied to their gain control pin. However, the AD8362’s output tends toward higher values as its input crosses over the level corresponding to the set-point, which would cause the PA’s output to increase further. In other words, the feedback polarity is reversed, forcing the control loop to latch up at one of its power extremes.

An increasing number of modular PAs feature a control polarity that reduces the power output with increases in control voltage. These can be controlled directly from the VOUT pin of the AD8362. Elsewhere, it is necessary to provide the sign inversion using a low noise buffer. This amplifier may also include provisions to ensure that the PA is never driven beyond its safe limits.

The complete details of such a control system depends on many factors, and this example shows only generic aspects of the design.

Use of an Input Balun

A balun (“balance to unbalance”) is used either to transform differential RF signals to single-ended form or in reverse, to convert single-sided signals to differential form. A typical balun consists simply of a short length of transmission line (miniature coax, or twisted pair) through which the signal passes without significant degradation, wound on a former (often a ferrite) to generate a “series-mode” inductor having a high reactive impedance, compared to the “through-mode” impedance of the transmission line, which is often 50 Ω .

High frequency common-mode voltages applied to the input of this line are sustained across this series reactance, and do not appear at the loaded side of the line. On the other hand, the “through-mode” bandwidth is very high, and the losses incurred in a short line of this sort are trivial.

Baluns of slightly more elaborate construction can provide an impedance transformation, usually designated by their impedance ratio, for example, 4:1, which becomes a 1:4 ratio when used in reverse, in order to convert a single-sided signal to the balanced form, as is desirable in driving the AD8362, while also presenting a 50 Ω input interface.

The evaluation board for the AD8362 includes such a 1:4 balun, part number M/A-COM ETC1.6-4-2-3, providing low loss coupling from 0.5 GHz to 2.5 GHz and an impedance transformation from the board’s 50 Ω input (at the SMA connector) to the 200 Ω differential input resistance of the AD8362. At high frequencies, the actual impedance at the connector will be influenced by reactive aspects of the IC’s input impedance. Since these can alter the magnitude of the input voltage, the logarithmic intercept cannot be precisely specified. However, the shift will be temperature-stable.

Note that the balun used here increases the signal voltage by the square root of its impedance ratio of 4:1, in this case by a factor of two. The use of a transformer to match the 500 Ω source to the 200 Ω load presented by the AD8362 thus increases the effective sensitivity of the measurement system by 6 dB, whether specified in dBV or dBm terms at the input to the transformer.

GENERAL APPLICATIONS

The unusual versatility of the AD8362 opens up many new possibilities whenever an element having an accurate rms response is needed. While developed primarily to address the need for true-power measurement in communications systems operating at frequencies as high as 2.7 GHz, the AD8362 is capable of meeting the requirements of instrumentation at much lower frequencies. As noted earlier, the AD8362 is unique in providing rms-to-dc conversion with a completely constant bandwidth, regardless of signal amplitude, and in providing a calibrated linear-in-dB measurement.

CAUTION: The applications shown here are provided only for illustrative purposes, and should not be regarded as ready for immediate incorporation into a user’s system. They have been validated for the present purpose by simulation studies.

AD8362

RMS Voltmeter with >100 dB Dynamic Range

The 60 dB range of the AD8362 can be extended by adding a stand-alone VGA as a preamplifier, whose gain control input is derived directly from VOUT. This extends the dynamic range by the gain control range of this second amplifier. When this VGA also provides a linear-in-dB (exponential) gain control function, the overall measurement remains linearly scaled in

decibels. The VGA gain must decrease with an increase in its gain bias, like the AD8362. It is convenient to select a VGA needing only a single 5 V supply, and capable of generating a fully balanced differential output. All of these conditions are met by the AD8330. Figure 24 shows the schematic. The signal can be applied to the AD8330 in either single-sided or differential form, using a variety of coupling arrangements (see its data sheet for more information).

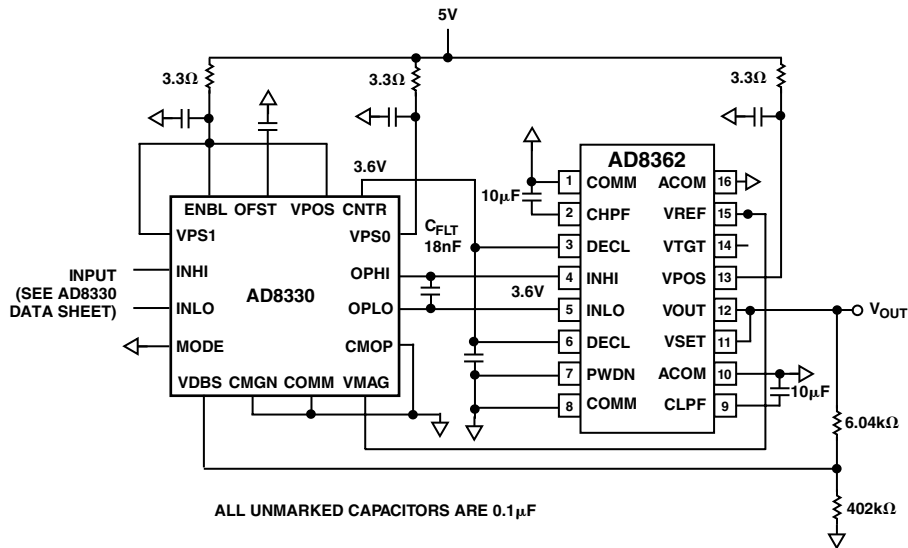

Figure 24. RMS Voltmeter with >100 dB Dynamic Range

The basic gain of the AD8330 varies from 0 dB to 50 dB. Here, it is raised 8 dB by driving VMAG from the 1.25 V available from the AD8362, whose 200 Ω loading on the 150 Ω R_{OUT} of the AD8330 in turn lowers the overall gain by 5 dB. The peak gain is thus ~53 dB. (Mismatches between the on-chip resistors in each IC can cause a gain error of up to 1.3 dB).

Using the AD8330's inverse gain mode (MODE pin low) its gain decreases on a slope of 30 mV/dB to a minimum value of 3 dB for a gain voltage (V_{DBS}) of 1.5 V. V_{DBS} is 40% of the AD8362's output. Over the 3 V range from 0.5 V to 3.5 V the gain of the AD8330 varies by $(0.4 \times 3 \text{ V}) / (30 \text{ mV/dB})$, that is, 40 dB. Combined with the 60 dB gain span of the AD8362, this results in a 100 dB variation, for a 3 V change in VOUT. The overall log slope is therefore 30 mV/dB.

The full-gain noise-spectral-density at the AD8330's input is 5 nV/ $\sqrt{\text{Hz}}$, which is raised (by 53 dB) to 2.2 mV/ $\sqrt{\text{Hz}}$ at its output. To realize the full 100 dB potential, the noise at the AD8362's input must be much less than 1 mV rms, which requires limiting the AD8330's noise bandwidth to ~100 kHz (when $e_N = 0.7 \text{ mV rms}$) provided by a single-pole low-pass section at the coupling interface, formed by $C_{FLT} = 18 \text{ nF}$ and the net differential resistance of 86 Ω (that is, $150 \Omega \parallel 200 \Omega$).

If optimized for use at lower frequencies, C_{FLT} should be increased accordingly; for audio applications, use 0.1 μF. In RF measurements where the carrier frequency is known, the coupling and bandwidth limiting between the ICs might be provided by a narrow-band SAW filter. Figure 25 shows the output and law-conformance error for this AD8330/AD8362 collaboration. The dynamic range extends from 5 μV to 0.5 V rms between the 0.5 dB error points in this simulation.

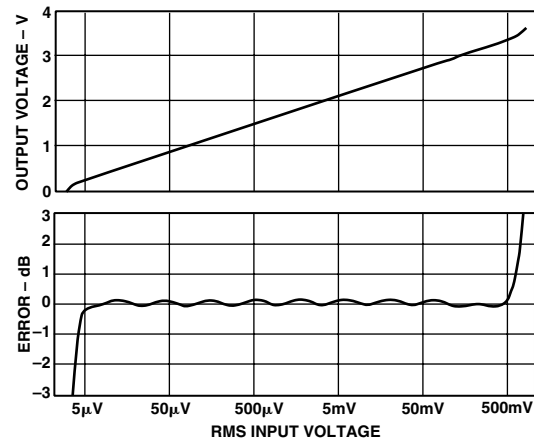

Figure 25. Output and Conformance for the AD8330/AD8362 Collaboration

RF Power Meter with 80 dB Range

According to simulations, the basic 60 dB measurement range of the AD8362 can be extended by up to 20 dB by using a target voltage V_{TGT} that increases progressively with the input level. In the simplest case, this can be achieved by connecting VTGT to the output VOUT/VSET. Figure 26 shows the

connections; for present purposes, R1 is omitted and R2 is short-circuited.

For small signal inputs, V_{OUT} is also small, and the target is well below the normal 75 mV (with 1.25 V applied to VTGT). The lower target means that the AD8362's VGA output does not have to be as large as normal, which increases the input sensitivity. As the signal increases, and thus V_{OUT} , so does the target voltage, which progressively shifts the required VGA input to a higher level.

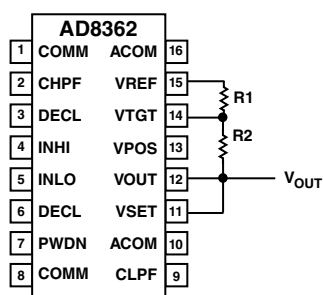

Figure 26. RF Power Meter with 80 dB Range

For example, a 10:1 change of V_{TGT} from 0.35 V to 3.5 V will shift the intercept by 20 dB. This has the effect of stretching the measurement range by the same amount, from >60 dB to more than 80 dB. So the slope decreases, to about 40 mV/dB, because a larger input range is now represented by the same 3.15 V. The simulation results shown in Figure 27 compare the expanded range response with that for a fixed V_{TGT} . The upper end of the measurement range is extended from 1.5 V to over 4 V (limited by the input protection).

However, it will be apparent that the transfer function is no longer a simple logarithmic law; further consideration shows that the modified function is nonanalytic. Nevertheless, this function is dependable, and it remains as stable over supply and temperature variations as in the normal mode. A good approximation is provided by

$$V_{OUT} = V_{SLP}' \left\{ \log_{10}(V_{IN}/V_Z) - 11.3m[\log_{10}(V_{IN})]^3 \right\} \quad (16)$$

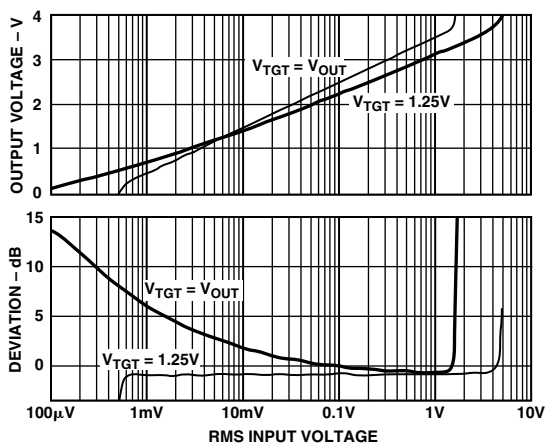

Figure 27. Dynamic Range Expansion Using $V_{TGT} = V_{OUT}$

where the modified slope voltage V_{SLP}' is 0.868 V, that is, 43.4 mV/dB. Using this expression, the dynamic range is 86 dB to the ± 0.5 dB error points ($0.2 \text{ mV} \leq V_{IN} \leq 4 \text{ V}$). The actual range will be reduced in practice by the effects of the AD8362's input-referred noise at low inputs. If the basic 60 dB+ range is only slightly less than required in a particular application, then just some fraction of V_{OUT} can be summed with a part of V_{REF} to the VTGT pin, which is why R1 and R2 were included. The output now conforms in general terms to the formula

$$V_{OUT} = V_{SLP}' \left\{ \log_{10}(V_{IN}/V_Z') - K_C [\log_{10}(V_{IN})]^3 \right\} \quad (17)$$

where the correction factor K_C introduces the required nonlinear correction to minimize the law-conformance error. Table II provides several representative spot values, using progressively greater amounts of dynamic range extension.

Table II. Suggested Values for use in Scheme of Figure 23

R1 (Ω)	R2 (Ω)	VSLP' (V/decade)	VZ' (mV)	K _C (m)
O/C	S/C	0.868	0.334	11.3
1904	96	0.870	0.336	10.4
1346	654	0.890	0.333	6.5
872	1128	0.914	0.340	3.7
480	1520	0.942	0.355	1.5
200	1800	0.972	0.380	0.5

High Slope Detectors Centered on a Narrow Window

The situation often arises in system monitoring in which an input signal varies by much less than 60 dB, and the highest possible sensitivity and accuracy of measurement is required within a narrow window of input magnitudes. Adapting the AD8362 to this task requires that the slope be increased, and the intercept repositioned. Using an attenuator from V_{OUT} to V_{SET} , any slope >50 mV/dB can be realized. Then, using a fraction of V_{REF} (or external reference voltage) the particular region of the dynamic range to be measured can be positioned wherever desired. In these high slope applications, the full rail-to-rail output swing of the AD8362 can be exploited.

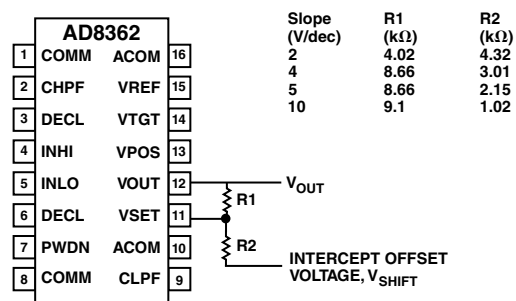

Figure 28. Slope and Intercept Adjustment

Figure 28 shows the basic connections for this mode of use; the intercept repositioning voltage V_{SHIFT} can be introduced by adding a third resistor from V_{REF} to V_{SET} , with recalculated values of R1 and R2, or by using an external voltage source. Figure 29 presents the simulation results for a log slope of 100 mV/dB (2 V/dec), covering 2-decade spans over several

AD8362

sub-ranges, while Figure 30 shows the results for a slope of 200 mV/dB (4 V/dec), providing just a one-decade span.

To accurately reposition the range (intercept) when very high slopes are used, a low output impedance DAC can be used to provide V_{SHIFT} . Figure 31 shows simulated results for a slope of 500 mV/dB (10 V/dec) presuming this elaboration.

In all cases, the fixed-pattern ripple in the log conformance remains unchanged, in dB terms. Residual fluctuations due to insufficient averaging (in low frequency applications) are likewise unaffected in their equivalent decibel value, though greater in absolute voltage terms.

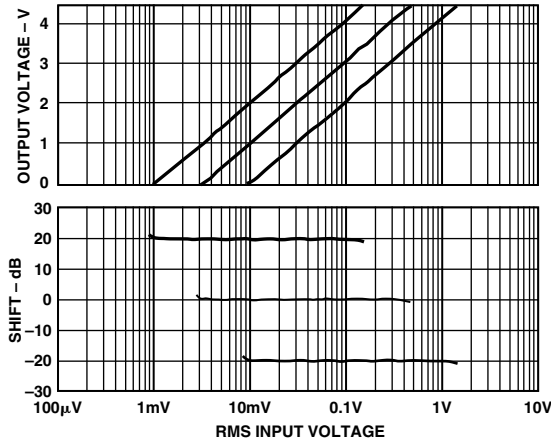

Figure 29. Illustrative Results for Slope of 100 mV/dB

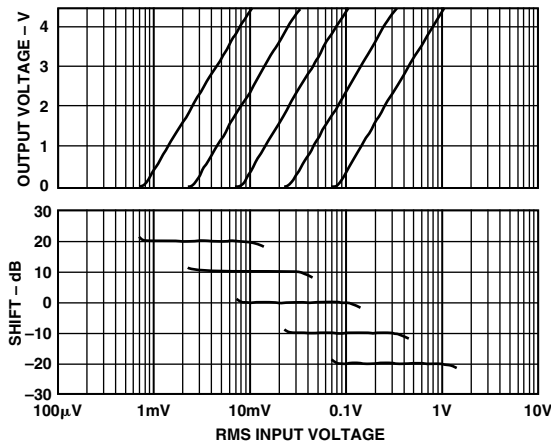

Figure 30. Illustrative Results for Slope of 200 mV/dB

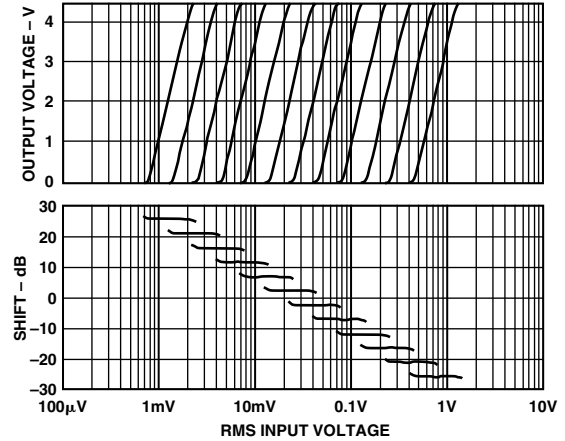

Figure 31. Illustrative Results for Slope of 10 V/dec

AD8362 Evaluation Board

The AD8362 evaluation board provides for a number of different operating modes, including many of those described above. The measurement mode is set up by positioning SW2 as shown in Figure 32. It can be operated in controller modes by removing LK1, flipping SW2 to its alternate position, and applying the set-point voltage to the V_{SET} connector.

The internal voltage reference is used for the target voltage when SW1 is in the position shown in Figure 32. This voltage may optionally be reduced via a voltage divider implemented with R4 and R5, with LK1 in place as shown and SW1 switched to its alternate position. Alternatively, an external target voltage may be used if SW1 is switched to its alternate position LK1 removed and the external target voltage is applied to the V_{TGT} connector.

In Measurement mode, the slope of the response at V_{OUT} may be increased through the use of a voltage divider implemented with the appropriate resistors, as explained earlier in the data sheet, in positions R17 and R18.

Operation of the AD8362 is powered up with SW3 in the position shown in Figure 32 and connector PWDN open. The part can be powered down either by connecting a logic HI to connector PWDN with SW3 in the position shown in Figure 32, or by switching SW3 to its alternate position.

Balun transformer T1 may be removed and replaced either by two capacitors and an inductor, as shown in Figure 17, or two 0 Ω resistors (links, size 0402), one in series with capacitors C6 and C10, the other in series with C5, and a 100 Ω resistor installed in position R16, to implement the circuit shown in Figure 16.

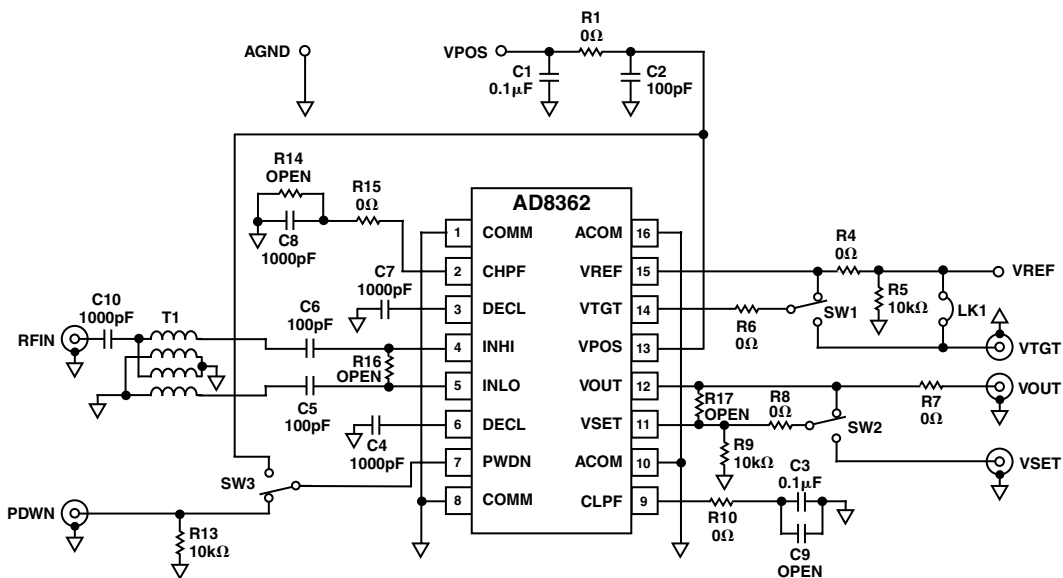

Figure 32. Evaluation Board Schematic

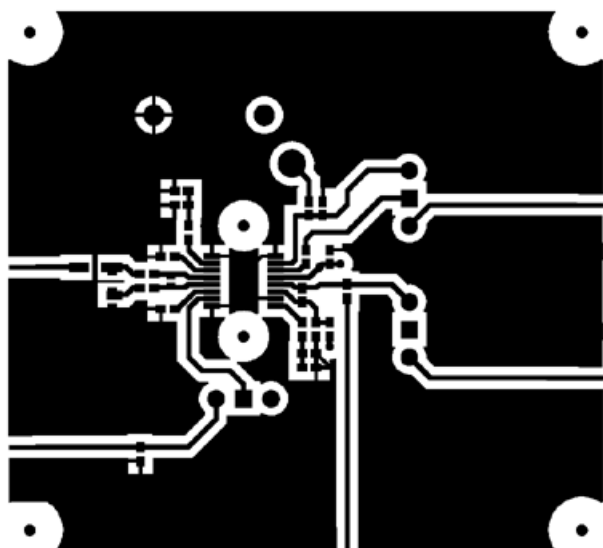

Figure 33. Component Side Metal of Evaluation Board

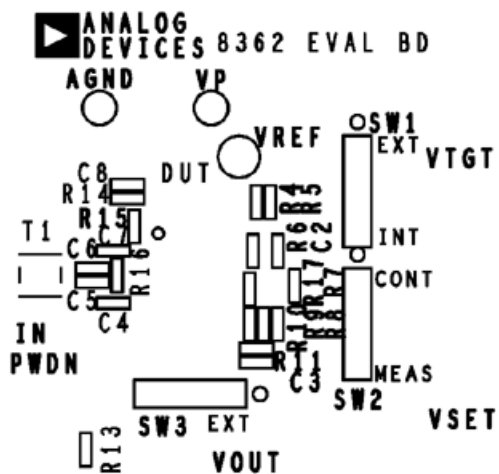

Figure 34. Component Side Silkscreen of Evaluation Board

AD8362

Table III. Evaluation Board Configuration Options

Component	Function	Part Number	Default Value
T1		ETC1.6-4-2-3	
C1	Supply filtering/decoupling capacitor		0.1 μ F
C2	Supply filtering/decoupling capacitor		100 pF
C3	Output low-pass filter capacitor		0.1 μ F
C9	Output low-pass filter capacitor (normally omitted, not installed)		
C4, C7, C10	Input bias-point decoupling capacitors		1000 pF
C5, C6	Input signal coupling capacitors		100 pF
C8	Input high-pass filter capacitor		1000 pF
DUT	AD8362	AD8362ARU	
R1, R4, R6, R7, R8, R10, R15			0 Ω
R5, R9, R13	Optional pull-down resistors		10 k Ω
R16	(not installed, see text)		100 Ω
R17	Slope adjustment (not installed, see text)		(See text)
RA	(Not installed, see text)		25 Ω or 0 Ω
RB	(Not installed, see text)		33 Ω
RC	(Not installed, see text)		0 Ω
SW1	Internal/external target voltage selector		
SW2	Measurement mode/controller mode selector		
SW3	Powerdown/enable or external power down selector		

C02923-0-11/02(0)

OUTLINE DIMENSIONS

16-Lead Thin Shrink Small Outline Package [TSSOP] (RU-16)

Dimensions shown in millimeters

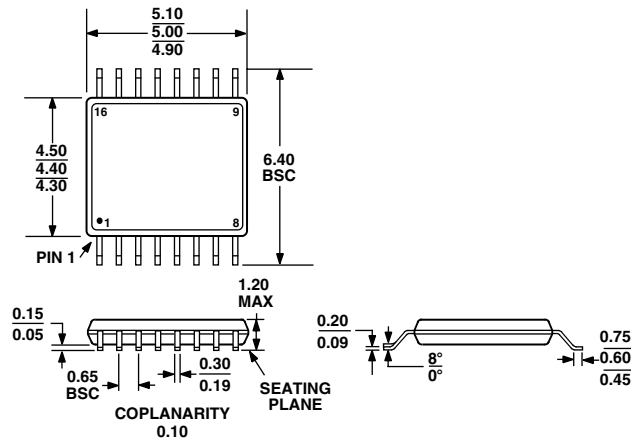

COMPLIANT TO JEDEC STANDARDS MO-153AB

PRINTED IN U.S.A.