

## 1.6V Nanopower Comparators with/without Internal References

### FEATURES

- ◆ Second-source for MAX9117-MAX9120
- ◆ Guaranteed to Operate Down to +1.6V
- ◆ Ultra-Low Supply Current
  - 350nA - TSM9119/TSM9120
  - 600nA - TSM9117/TSM9118
- ◆ Internal 1.252V  $\pm$ 1.75% Reference
- ◆ Input Voltage Range Extends 200mV Outside-the-Rails
- ◆ No Phase Reversal for Overdriven Inputs
- ◆ Push-pull and Open-Drain Output Versions Available
- ◆ Crowbar-Current-Free Switching
- ◆ Internal Hysteresis for Clean Switching
- ◆ 5-pin SC70 and 8-pin SOIC Packaging

### APPLICATIONS

2-Cell Battery Monitoring/Management  
 Medical Instruments  
 Threshold Detectors/Discriminators  
 Sensing at Ground or Supply Line  
 Ultra-Low-Power Systems  
 Mobile Communications  
 Telemetry and Remote Systems

### DESCRIPTION

The TSM9117–TSM9120 family of nanopower comparators is electrically and form-factor identical to the MAX9117-MAX9120 family of analog comparators. Ideally suited for all 2-cell battery-management/monitoring applications, these 5-pin SC70 analog comparators guarantee +1.6V operation, draw very little supply current, and have robust input stages that can tolerate input voltages beyond the power supply. The TSM9117 and the TSM9118 draw 600nA of supply current and include an on-board 1.252V  $\pm$ 1.75% reference. The comparator-only TSM9119 and the TSM9120 draw a supply current of 350nA.

The TSM9117 and TSM9119's push-push output drivers were designed to drive 5mA loads from one supply rail to the other supply rail. The TSM9118 and the TSM9120's open-drain output stages make it easy to incorporate these comparators into systems that operate on different supply voltages.

### TYPICAL APPLICATION CIRCUIT

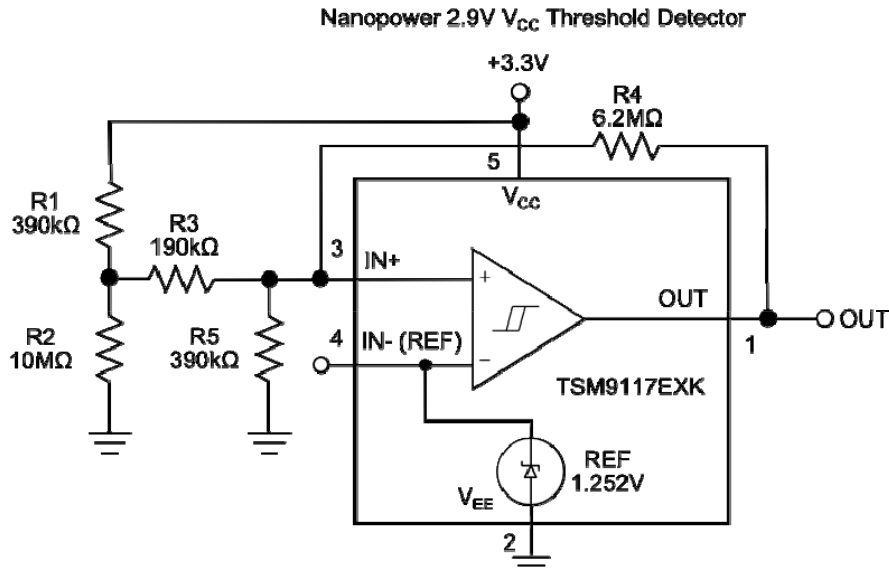

| PART    | INTERNAL REFERENCE | OUTPUT TYPE | SUPPLY CURRENT (nA) |
|---------|--------------------|-------------|---------------------|
| TSM9117 | Yes                | Push-Pull   | 600                 |
| TSM9118 | Yes                | Open-Drain  | 600                 |
| TSM9119 | No                 | Push-Pull   | 350                 |
| TSM9120 | No                 | Open-Drain  | 350                 |

The Touchstone Semiconductor logo is a registered trademark of Touchstone Semiconductor, Incorporated.

# TSM9117-TSM9120



## ABSOLUTE MAXIMUM RATINGS

Supply Voltage ( $V_{CC}$  to  $V_{EE}$ ) ..... +6V  
 Voltage Inputs ( $IN+$ ,  $IN-$ , REF) .... ( $V_{EE} - 0.3V$ ) to ( $V_{CC} + 0.3V$ )  
 Output Voltage  
   TSM9117/9119 ..... ( $V_{EE} - 0.3V$ ) to ( $V_{CC} + 0.3V$ )  
   TSM9118/9120 ..... ( $V_{EE} - 0.3V$ ) to +6V  
 Current Into Input Pins .....  $\pm 20mA$   
 Output Current .....  $\pm 50mA$   
 Output Short-Circuit Duration ..... 10s

Continuous Power Dissipation ( $T_A = +70^\circ C$ )  
   5-Pin SC70 (Derate 2.5mW/ $^\circ C$  above  $+70^\circ C$ ) ..... 200mW  
   8-Pin SOIC (Derate 5.88mW/ $^\circ C$  above  $+70^\circ C$ ) ..... 471mW  
 Operating Temperature Range .....  $-40^\circ C$  to  $+85^\circ C$   
 Junction Temperature .....  $+150^\circ C$   
 Storage Temperature Range .....  $-65^\circ C$  to  $+150^\circ C$   
 Lead Temperature (soldering, 10s) .....  $+300^\circ$

Electrical and thermal stresses beyond those listed under "Absolute Maximum Ratings" may cause permanent damage to the device. These are stress ratings only and functional operation of the device at these or any other condition beyond those indicated in the operational sections of the specifications is not implied. Exposure to any absolute maximum rating conditions for extended periods may affect device reliability and lifetime.

## PACKAGE/ORDERING INFORMATION

| <p><b>SC70-5<br/>XK Package</b><br/>IN- (REF) Pin 4 - TSM9117/TSM9118 only</p> |              |             |          | <p><b>SO-8<br/>SA Package</b><br/>IN- (REF) Pin 2 - TSM9117 only</p> |              |             |          |
|--|--------------|-------------|----------|--|--------------|-------------|----------|
| ORDER NUMBER   | PART MARKING | CARRIER     | QUANTITY | ORDER NUMBER   | PART MARKING | CARRIER     | QUANTITY |
| TSM9117EXK+T   | TAA          | Tape & Reel | 3000     | TSM9117ESA+  | TS9117E      | Tube        | 97       |
| TSM9118EXK+T   | TAB          | Tape & Reel | 3000     | TSM9117ESA+T   |              | Tape & Reel | 2500     |
| TSM9119EXK+T   | TAC          | Tape & Reel | 3000     | TSM9120ESA+  | TS9120E      | Tube        | 97       |
| TSM9120EXK+T   | TAD          | Tape & Reel | 3000     | TSM9120ESA+T   |              | Tape & Reel | 2500     |

**Lead-free Program:** Touchstone Semiconductor supplies only lead-free packaging.

Consult Touchstone Semiconductor for products specified with wider operating temperature ranges.

## ELECTRICAL CHARACTERISTICS: TSM9117 & TSM9118

$V_{CC} = +5V$ ,  $V_{EE} = 0V$ ,  $V_{IN+} = V_{REF}$ ,  $T_A = -40^{\circ}C$  to  $+85^{\circ}C$ , unless otherwise noted. Typical values are at  $T_A = +25^{\circ}C$ . See Note 1.

| PARAMETER                                 | SYMBOL                            | CONDITIONS   | MIN   | TYP     | MAX            | UNITS            |
|---|-----------------------------------|--|---|---------|----------------|------------------|
| Supply Voltage Range                      | $V_{CC}$                          | Inferred from the PSRR test                              | $T_A = +25^{\circ}C$                              | 1.6     | 5.5            | V                |
|   |                                   |  | $T_A = T_{MIN}$ to $T_{MAX}$                      | 1.8     | 5.5            |                  |
| Supply Current                            | $I_{CC}$                          | $V_{CC} = 1.6V$  | $T_A = +25^{\circ}C$                              | 0.6     | 1              | $\mu A$          |
|   |                                   |  | $T_A = T_{MIN}$ to $T_{MAX}$                      | 0.68    | 1.30           |                  |
|   |                                   | $V_{CC} = 5V$  | $T_A = T_{MIN}$ to $T_{MAX}$                      |         | 1.60           |                  |
| IN+ Voltage Range                         | $V_{IN+}$                         | Inferred from the output swing test                      | $V_{EE} - 0.2$                                    |         | $V_{CC} + 0.2$ | V                |
| Input Offset Voltage                      | $V_{OS}$                          | (Note 2)   | $T_A = +25^{\circ}C$                              | 1       | 5              | mV               |
|   |                                   |  | $T_A = T_{MIN}$ to $T_{MAX}$                      |         | 10             |                  |
| Input-Referred Hysteresis                 | $V_{HB}$                          | (Note 3)   |   | 4       |                | mV               |
| Input Bias Current                        | $I_B$                             | $T_A = +25^{\circ}C$                                     |   | 0.15    | 1              | nA               |
|   |                                   | $T_A = T_{MIN}$ to $T_{MAX}$                             |   |         | 2              |                  |
| Power-Supply Rejection Ratio              | PSRR                              | $V_{CC} = 1.6V$ to $5.5V$ , $T_A = +25^{\circ}C$         |   | 0.1     | 1              | mV/V             |
|   |                                   | $V_{CC} = 1.8V$ to $5.5V$ , $T_A = T_{MIN}$ to $T_{MAX}$ |   |         | 1              | mV/V             |
| Output-Voltage Swing High                 | $V_{CC} - V_{OH}$                 | TSM9117, $V_{CC} = 5V$ ,<br>$I_{SOURCE} = 5mA$           | $T_A = +25^{\circ}C$                              | 190     | 400            | mV               |
|   |                                   |  | $T_A = T_{MIN}$ to $T_{MAX}$                      |         | 500            |                  |
|   |                                   | TSM9117,<br>$I_{SOURCE} = 1mA$                           | $V_{CC} = 1.6V$ ,<br>$T_A = +25^{\circ}C$         | 100     | 200            |                  |
|   |                                   |  | $V_{CC} = 1.8V$ ,<br>$T_A = T_{MIN}$ to $T_{MAX}$ |         | 300            |                  |
| Output-Voltage Swing Low                  | $V_{OL}$                          | $V_{CC} = 5V$ , $I_{SINK} = 5mA$                         | $T_A = +25^{\circ}C$                              | 190     | 400            | mV               |
|   |                                   |  | $T_A = T_{MIN}$ to $T_{MAX}$                      |         | 500            |                  |
|   |                                   | $I_{SINK} = 1mA$   | $V_{CC} = 1.6V$ ,<br>$T_A = +25^{\circ}C$         | 100     | 200            |                  |
|   |                                   |  | $V_{CC} = 1.8V$ ,<br>$T_A = T_{MIN}$ to $T_{MAX}$ |         | 300            |                  |
| Output Leakage Current                    | $I_{LEAK}$                        | TSM9118 only, $V_O = 5.5V$                               |   | 0.002   | 1              | $\mu A$          |
| Output Short-Circuit Current              | $I_{SC}$                          | Sourcing, $V_O = V_{EE}$                                 | $V_{CC} = 5V$                                     | 35      |                | mA               |
|   |                                   |  | $V_{CC} = 1.6V$                                   | 3       |                |                  |
|   |                                   | Sinking, $V_O = V_{CC}$                                  | $V_{CC} = 5V$                                     | 35      |                |                  |
|   |                                   |  | $V_{CC} = 1.6V$                                   | 3       |                |                  |
| High-to-Low Propagation Delay (Note 4)    | $t_{PD-}$                         | $V_{CC} = 1.6V$  |   | 16      |                | $\mu s$          |
|   |                                   | $V_{CC} = 5V$  |   | 14      |                |                  |
| Low-to-High Propagation Delay (Note 4)    | $t_{PD+}$                         | TSM9117 only   | $V_{CC} = 1.6V$                                   | 15      |                | $\mu s$          |
|   |                                   |  | $V_{CC} = 5V$                                     | 40      |                |                  |
|   |                                   | TSM9118 only   | $V_{CC} = 1.6V$ ,<br>$R_{PULLUP} = 100k\Omega$    | 16      |                |                  |
|   |                                   |  | $V_{CC} = 5V$ ,<br>$R_{PULLUP} = 100k\Omega$      | 45      |                |                  |
| Rise Time                                 | $t_{RISE}$                        | TSM9117 only, $C_L = 15pF$                               |   | 1.6     |                | $\mu s$          |
| Fall Time                                 | $t_{FALL}$                        | $C_L = 15pF$   |   | 0.2     |                | $\mu s$          |
| Power-Up Time                             | $t_{ON}$                          |  |   | 1.2     |                | ms               |
| Reference Voltage                         | $V_{REF}$                         | $T_A = +25^{\circ}C$                                     | 1.230   | 1.252   | 1.274          | V                |
|   |                                   | $T_A = T_{MIN}$ to $T_{MAX}$                             | 1.196   |         | 1.308          |                  |
| Reference Voltage Temperature Coefficient | $TCV_{REF}$                       |  |   | 100     |                | ppm/ $^{\circ}C$ |
| Reference Output Voltage Noise            | $e_n$                             | BW = 10Hz to 100kHz                                      |   | 1.1     |                | $mV_{RMS}$       |
|   |                                   | BW = 10Hz to 100kHz, $C_{REF} = 1nF$                     |   | 0.2     |                |                  |
| Reference Line Regulation                 | $\Delta V_{REF} / \Delta V_{CC}$  | $V_{CC} = 1.6V$ to $5.5V$                                |   | 0.25    |                | mV/V             |
| Reference Load Regulation                 | $\Delta V_{REF} / \Delta I_{OUT}$ | $\Delta I_{OUT} = 10nA$                                  |   | $\pm 1$ |                | mV/nA            |

# TSM9117-TSM9120



## ELECTRICAL CHARACTERISTICS: TSM9119 & TSM9120

$V_{CC} = +5V$ ,  $V_{EE} = 0V$ ,  $V_{CM} = 0V$ ,  $T_A = -40^{\circ}C$  to  $+85^{\circ}C$ , unless otherwise noted. Typical values are at  $T_A = +25^{\circ}C$ . See Note 1.

| PARAMETER                              | SYMBOL            | CONDITIONS   | MIN   | TYP   | MAX            | UNITS   |    |
|--|-------------------|--|---|-------|----------------|---------|----|
| Supply Voltage Range                   | $V_{CC}$          | Inferred from the PSRR test                              | $T_A = +25^{\circ}C$                              | 1.6   | 5.5            | V       |    |
|  |                   |  | $T_A = T_{MIN}$ to $T_{MAX}$                      | 1.8   | 5.5            |         |    |
| Supply Current                         | $I_{CC}$          | $V_{CC} = 1.6V$  | $T_A = +25^{\circ}C$                              | 0.35  | 0.80           | $\mu A$ |    |
|  |                   |  | $T_A = T_{MIN}$ to $T_{MAX}$                      | 0.45  | 0.80           |         |    |
|  |                   | $V_{CC} = 5V$  |   |       | 1.20           |         |    |
| Input Common-Mode Voltage Range        | $V_{CM}$          | Inferred from the CMRR test                              | $V_{EE} - 0.2$                                    |       | $V_{CC} + 0.2$ | V       |    |
| Input Offset Voltage                   | $V_{OS}$          | $-0.2V \leq V_{CM} \leq (V_{CC} + 0.2V)$<br>(Note 2)     | $T_A = +25^{\circ}C$                              | 1     | 5              | mV      |    |
|  |                   |  | $T_A = T_{MIN}$ to $T_{MAX}$                      |       | 10             |         |    |
| Input-Referred Hysteresis              | $V_{HB}$          | $-0.2V \leq V_{CM} \leq (V_{CC} + 0.2V)$ (Note 3)        |   | 4     |                | mV      |    |
| Input Bias Current                     | $I_B$             | $T_A = +25^{\circ}C$                                     |   | 0.15  | 1              | nA      |    |
|  |                   | $T_A = T_{MIN}$ to $T_{MAX}$                             |   |       | 2              |         |    |
| Input Offset Current                   | $I_{OS}$          |  |   | 75    |                | pA      |    |
| Power-Supply Rejection Ratio           | PSRR              | $V_{CC} = 1.6V$ to $5.5V$ , $T_A = +25^{\circ}C$         |   | 0.1   | 1              | mV/V    |    |
|  |                   | $V_{CC} = 1.8V$ to $5.5V$ , $T_A = T_{MIN}$ to $T_{MAX}$ |   |       | 1              |         |    |
| Common-Mode Rejection Ratio            | CMRR              | $(V_{EE} - 0.2V) \leq V_{CM} \leq (V_{CC} + 0.2V)$       |   | 0.5   | 3              | mV/V    |    |
| Output-Voltage Swing High              | $V_{CC} - V_{OH}$ | TSM9119 only, $V_{CC} = 5V$ ,<br>$I_{SOURCE} = 5mA$      | $T_A = +25^{\circ}C$                              |       | 190            | 400     | mV |
|  |                   |  | $T_A = T_{MIN}$ to $T_{MAX}$                      |       |                | 500     |    |
|  |                   | TSM9119 only,<br>$I_{SOURCE} = 1mA$                      | $V_{CC} = 1.6V$ ,<br>$T_A = +25^{\circ}C$         |       | 100            | 200     |    |
|  |                   |  | $V_{CC} = 1.8V$ ,<br>$T_A = T_{MIN}$ to $T_{MAX}$ |       |                | 300     |    |
| Output-Voltage Swing Low               | $V_{OL}$          | $V_{CC} = 5V$ , $I_{SINK} = 5mA$                         | $T_A = +25^{\circ}C$                              |       | 190            | 400     | mV |
|  |                   |  | $T_A = T_{MIN}$ to $T_{MAX}$                      |       |                | 500     |    |
|  |                   | $I_{SINK} = 1mA$   | $V_{CC} = 1.6V$ ,<br>$T_A = +25^{\circ}C$         |       | 100            | 200     |    |
|  |                   |  | $V_{CC} = 1.8V$ ,<br>$T_A = T_{MIN}$ to $T_{MAX}$ |       |                | 300     |    |
| Output Leakage Current                 | $I_{LEAK}$        | TSM9120 only, $V_O = 5.5V$                               |   | 0.001 | 1              | $\mu A$ |    |
| Output Short-Circuit Current           | $I_{SC}$          | Sourcing, $V_O = V_{EE}$                                 | $V_{CC} = 5V$                                     |       | 35             | mA      |    |
|  |                   |  | $V_{CC} = 1.6V$                                   |       | 3              |         |    |
|  |                   | Sinking, $V_O = V_{CC}$                                  | $V_{CC} = 5V$                                     |       | 35             |         |    |
|  |                   |  | $V_{CC} = 1.6V$                                   |       | 3              |         |    |
| High-to-Low Propagation Delay (Note 4) | $t_{PD-}$         | $V_{CC} = 1.6V$  |   | 16    |                | $\mu s$ |    |
|  |                   | $V_{CC} = 5V$  |   | 14    |                |         |    |
| Low-to-High Propagation Delay (Note 4) | $t_{PD+}$         | TSM9119 only   | $V_{CC} = 1.6V$                                   |       | 15             | $\mu s$ |    |
|  |                   |  | $V_{CC} = 5V$                                     |       | 40             |         |    |
|  |                   | TSM9120 only   | $V_{CC} = 1.6V$ ,<br>$R_{PULLUP} = 100k\Omega$    |       | 16             |         |    |
|  |                   |  | $V_{CC} = 5V$ ,<br>$R_{PULLUP} = 100k\Omega$      |       | 45             |         |    |
| Rise Time                              | $t_{RISE}$        | TSM9119 only, $C_L = 15pF$                               |   | 1.6   |                | $\mu s$ |    |
| Fall Time                              | $t_{FALL}$        | $C_L = 15pF$   |   | 0.2   |                | $\mu s$ |    |
| Power-Up Time                          | $t_{ON}$          |  |   | 1.2   |                | ms      |    |

**Note 1:** All specifications are 100% tested at  $T_A = +25^{\circ}C$ . Specification limits over temperature ( $T_A = T_{MIN}$  to  $T_{MAX}$ ) are guaranteed by design, not production tested.

**Note 2:**  $V_{OS}$  is defined as the center of the hysteresis band at the input.

**Note 3:** The hysteresis-related trip points are defined by the edges of the hysteresis band, measured with respect to the center of the hysteresis band (i.e.,  $V_{OS}$ ) (See Figure 2).

**Note 4:** Specified with an input overdrive ( $V_{OVERDRIVE}$ ) of 100mV, and load capacitance of  $C_L = 15pF$ .  $V_{OVERDRIVE}$  is defined above and beyond the offset voltage and hysteresis of the comparator input. For the TSM9117/TSM9118, reference voltage error should also be added.

## TYPICAL PERFORMANCE CHARACTERISTICS

$V_{CC} = +5V$ ;  $V_{EE} = 0V$ ;  $C_L = 15pF$ ;  $V_{OVERDRIVE} = 100mV$ ;  $T_A = +25^\circ C$ , unless otherwise noted.

**TSM9117/9118 Supply Current vs Supply Voltage and Temperature**

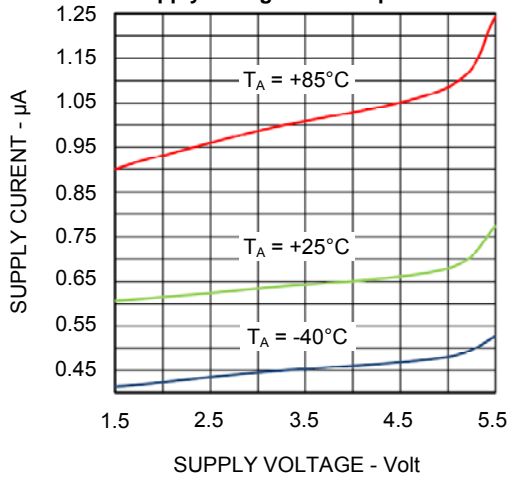

**TSM9119/9120 Supply Current vs Supply Voltage and Temperature**

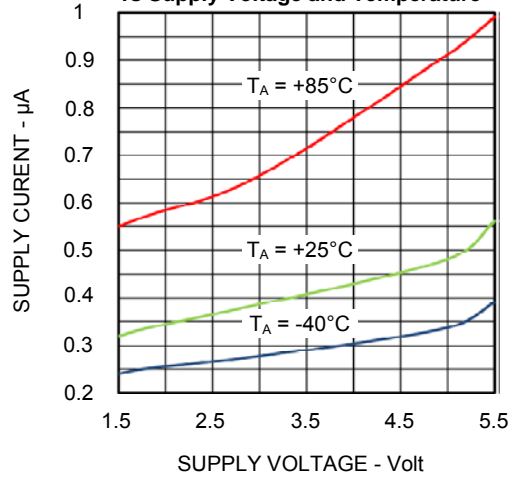

**TSM9117/9118 Supply Current vs Temperature**

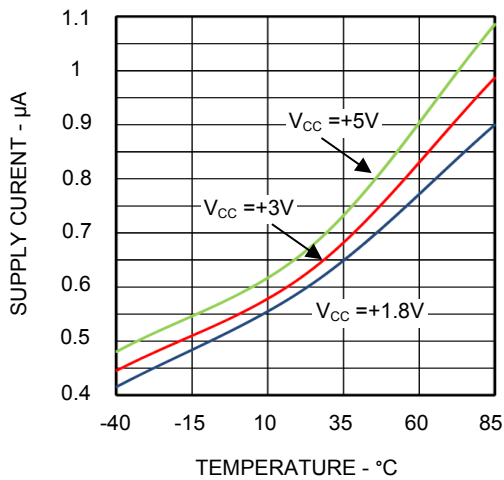

**TSM9119/9120 Supply Current vs Temperature**

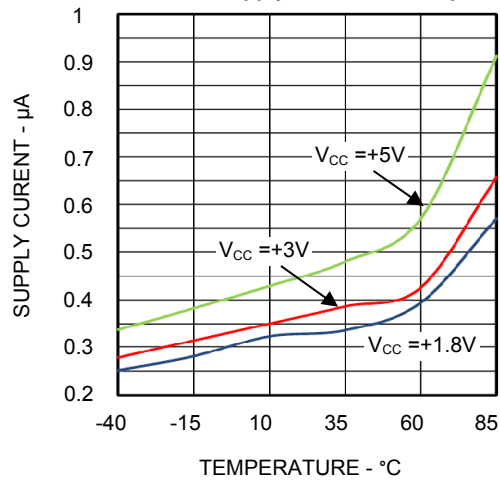

**TSM9117/9118 Supply Current vs Output Transition Frequency**

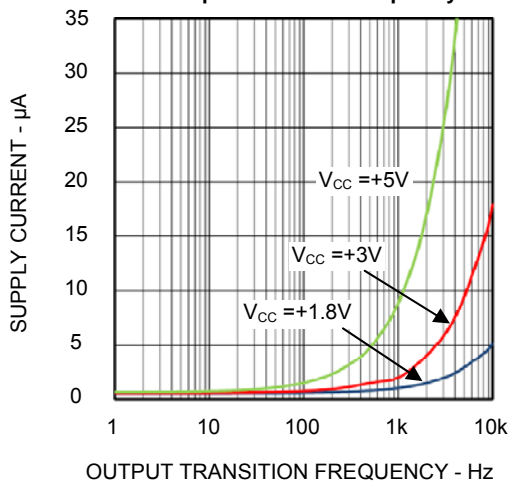

**TSM9119/9120 Supply Current vs Output Transition Frequency**

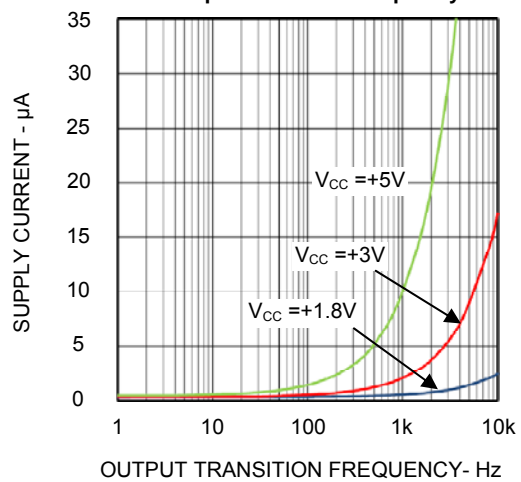

# TSM9117-TSM9120



## TYPICAL PERFORMANCE CHARACTERISTICS

$V_{CC} = +5V$ ;  $V_{EE} = 0V$ ;  $C_L = 15pF$ ;  $V_{OVERDRIVE} = 100mV$ ;  $T_A = +25^\circ C$ , unless otherwise noted.

Output Voltage Low vs. Sink Current

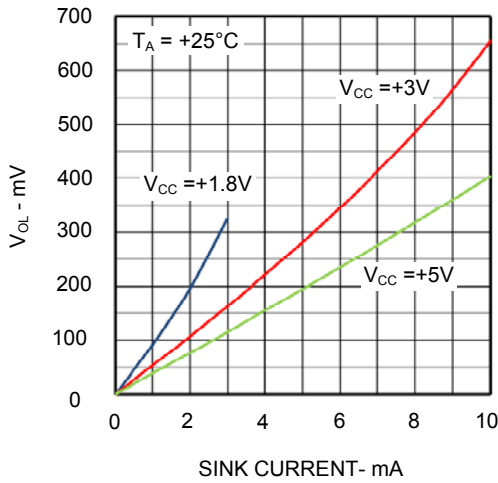

Output Voltage Low vs. Sink Current and Temperature

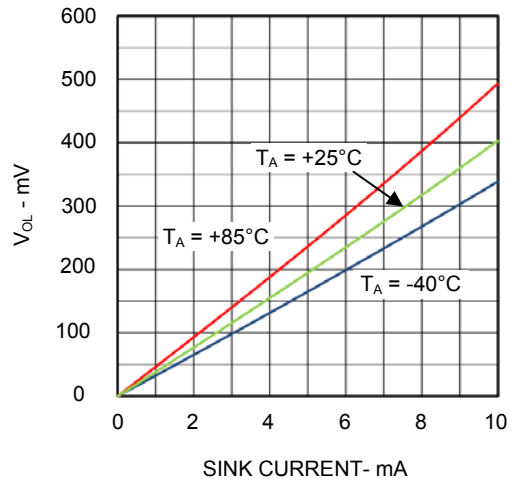

TSM9117/9119 Output Voltage High vs Source Current

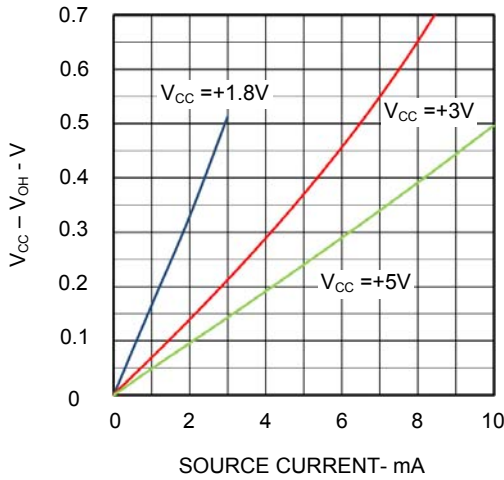

TSM9117/9119 Output Voltage High vs Source Current and Temperature

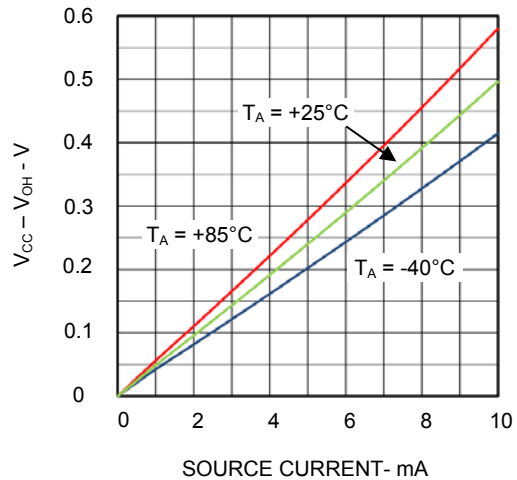

Short-Circuit Sink Current vs Temperature

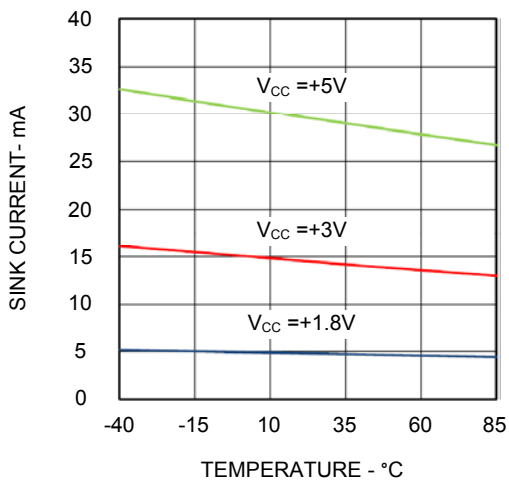

TSM9117/9119 Short-Circuit Source Current vs Temperature

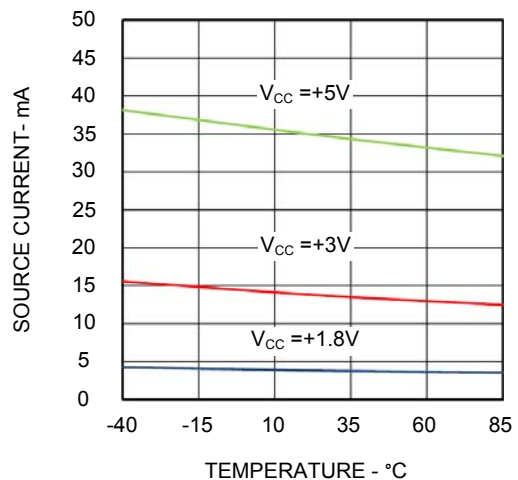

## TYPICAL PERFORMANCE CHARACTERISTICS

$V_{CC} = +5V$ ;  $V_{EE} = 0V$ ;  $C_L = 15pF$ ;  $V_{OVERDRIVE} = 100mV$ ;  $T_A = +25^{\circ}C$ , unless otherwise noted.

Offset Voltage vs Temperature

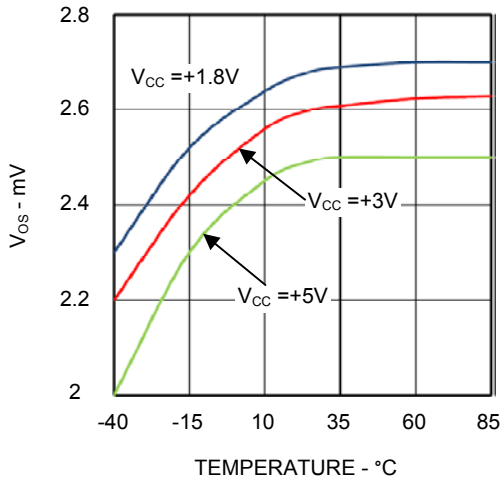

Hysteresis Voltage vs Temperature

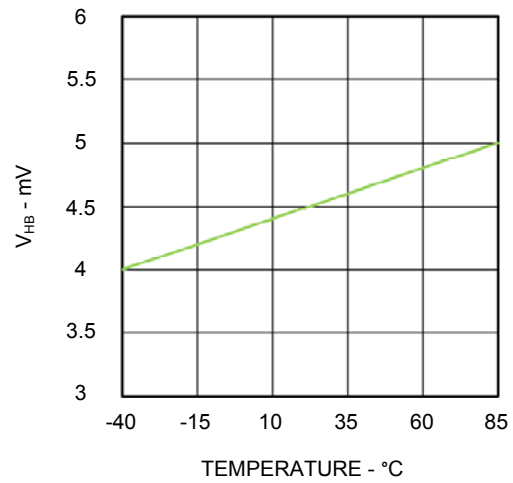

TSM9117/9118 Reference Voltage vs Temperature

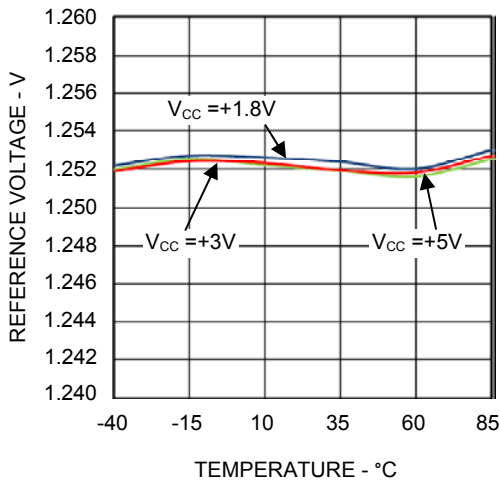

TSM9117/9118 Reference Voltage vs Supply Voltage

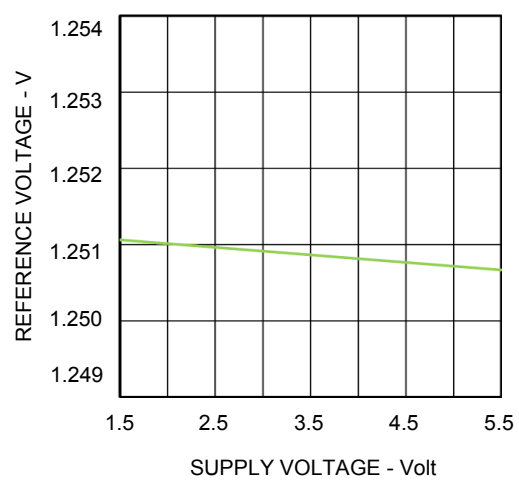

TSM9117/9118 Reference Voltage vs Reference Source Current

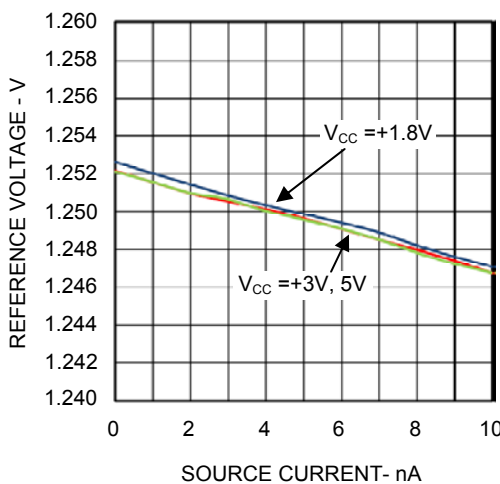

TSM9117/9118 Reference Voltage vs Reference Sink Current

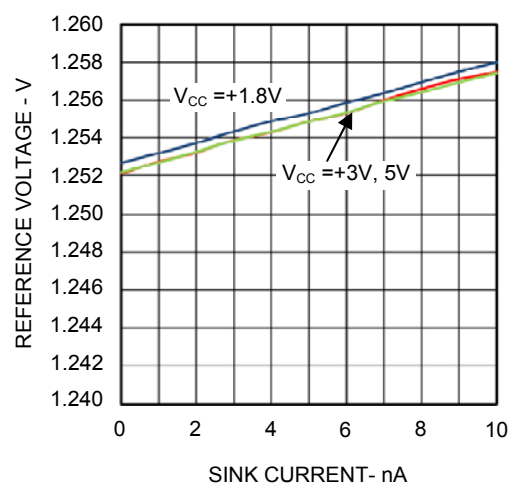

# TSM9117-TSM9120



## TYPICAL PERFORMANCE CHARACTERISTICS

$V_{CC} = +5V$ ;  $V_{EE} = 0V$ ;  $C_L = 15pF$ ;  $V_{OVERDRIVE} = 100mV$ ;  $T_A = +25^{\circ}C$ , unless otherwise noted.

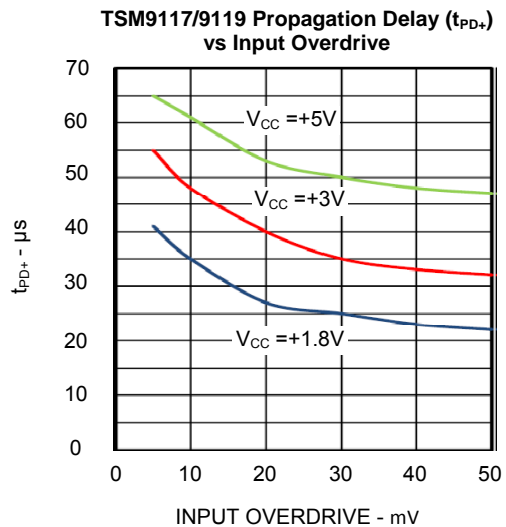
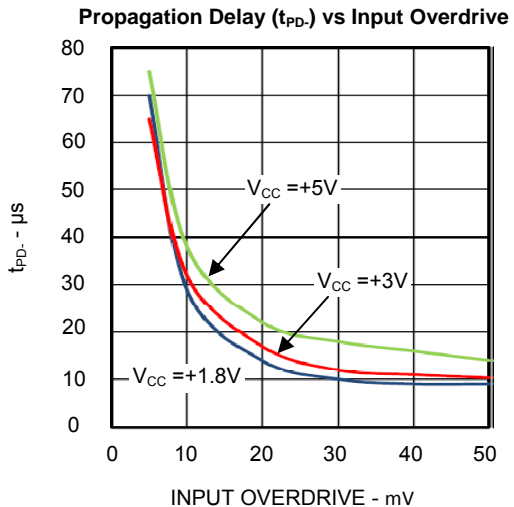
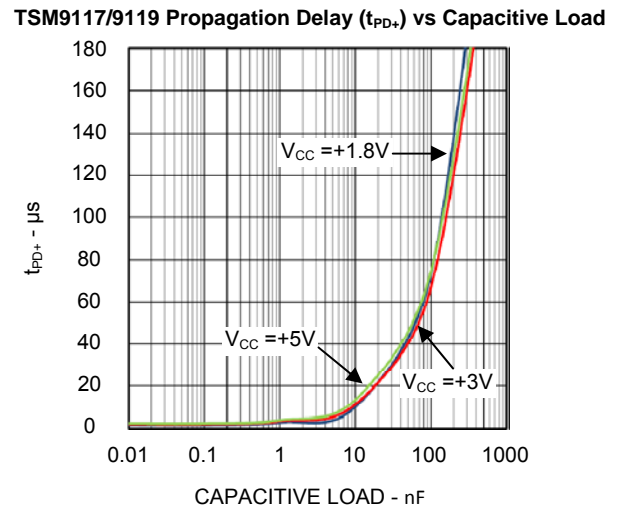
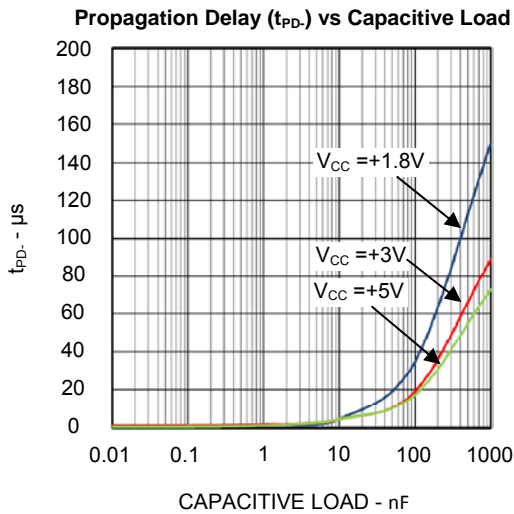
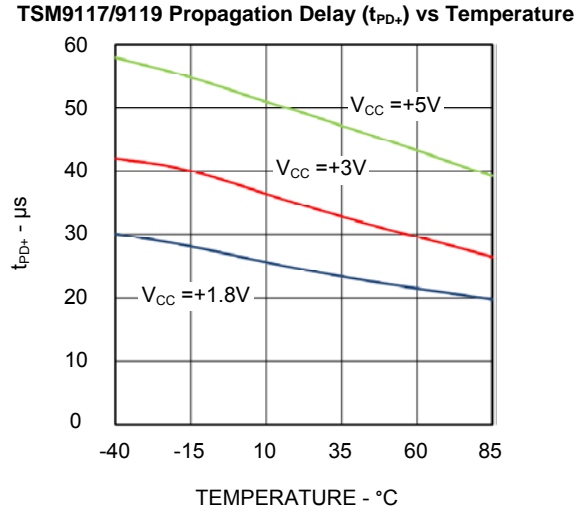
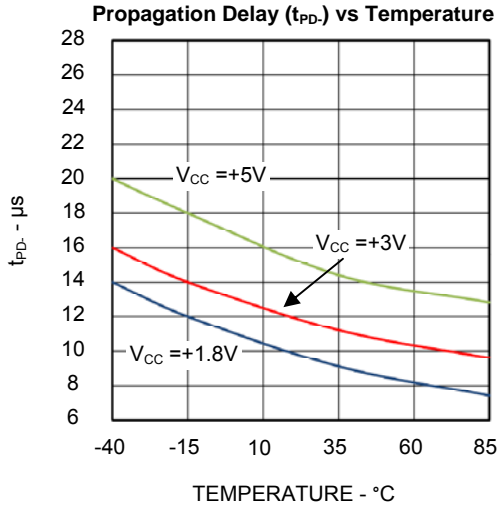



## TYPICAL PERFORMANCE CHARACTERISTICS

$V_{CC} = +5V$ ;  $V_{EE} = 0V$ ;  $C_L = 15pF$ ;  $V_{OVERDRIVE} = 100mV$ ;  $T_A = +25^\circ C$ , unless otherwise noted.

TSM9118/9120 Propagation Delay ( $t_{PD}$ ) vs Pullup Resistance

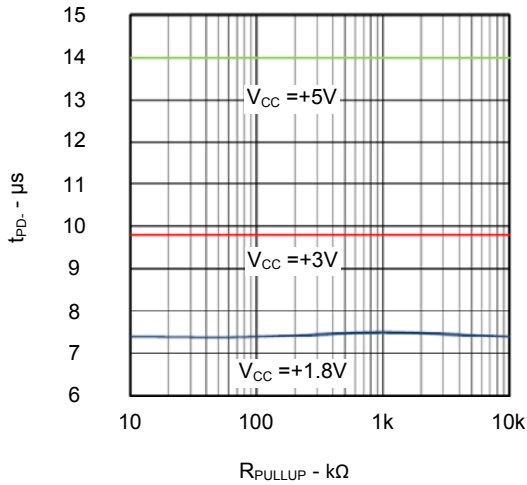

TSM9118/9120 Propagation Delay ( $t_{PD+}$ ) vs Pullup Resistance

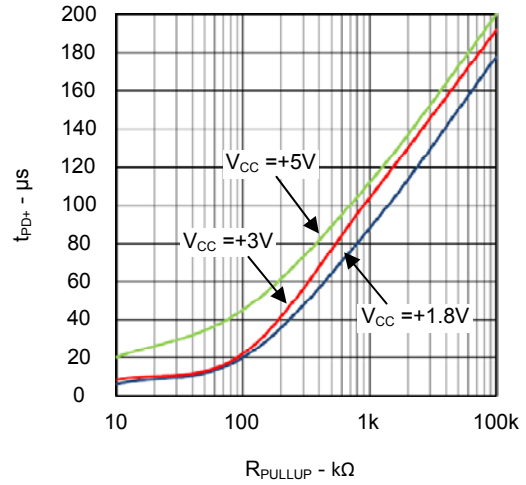

Propagation Delay ( $t_{PD}$ ) at  $V_{CC} = +5V$

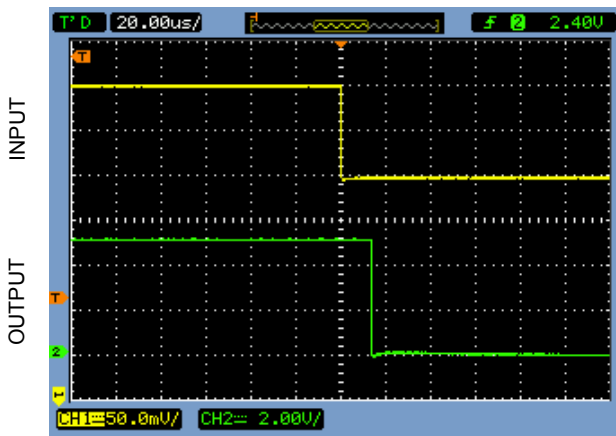

20 $\mu s$ /DIV

TSM9117/9119  
Propagation Delay ( $t_{PD+}$ ) at  $V_{CC} = +5V$

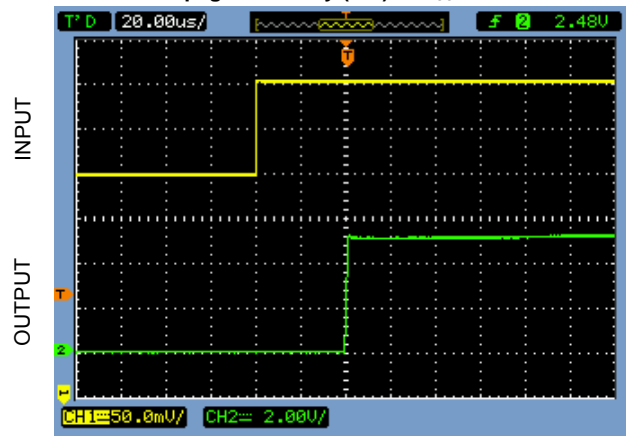

20 $\mu s$ /DIV

Propagation Delay ( $t_{PD}$ ) at  $V_{CC} = +3V$

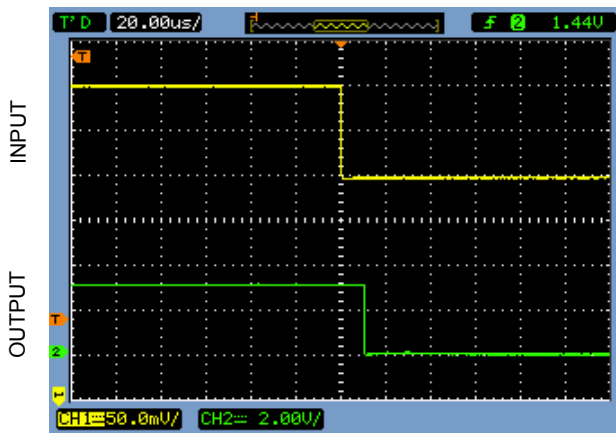

20 $\mu s$ /DIV

TSM9117/9119  
Propagation Delay ( $t_{PD+}$ ) at  $V_{CC} = +3V$

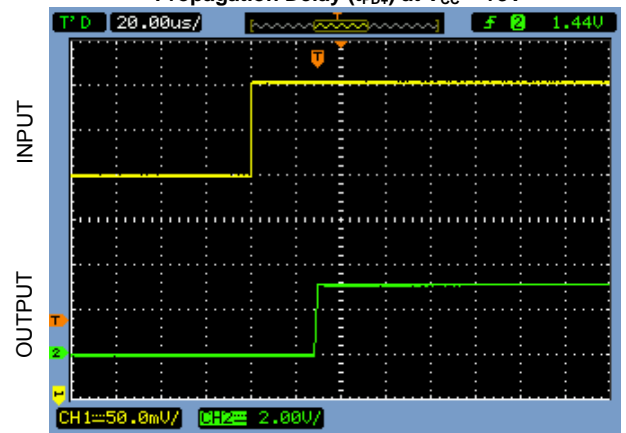

20 $\mu s$ /DIV

# TSM9117-TSM9120



## TYPICAL PERFORMANCE CHARACTERISTICS

$V_{CC} = +5V$ ;  $V_{EE} = 0V$ ;  $C_L = 15pF$ ;  $V_{OVERDRIVE} = 100mV$ ;  $T_A = +25^{\circ}C$ , unless otherwise noted.

Propagation Delay ( $t_{PD-}$ ) at  $V_{CC} = +1.8V$

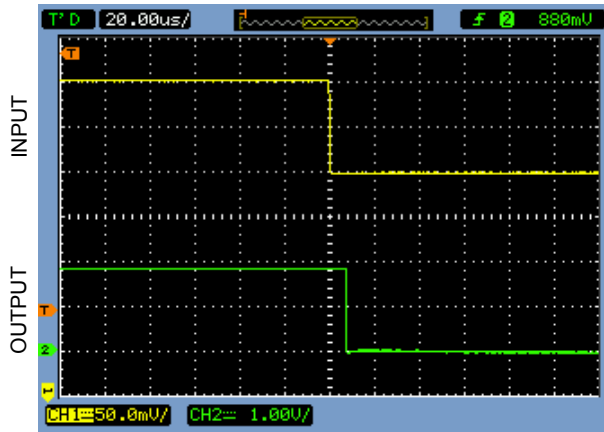

20µs/DIV

TSM9117/9119  
Propagation Delay ( $t_{PD+}$ ) at  $V_{CC} = +1.8V$

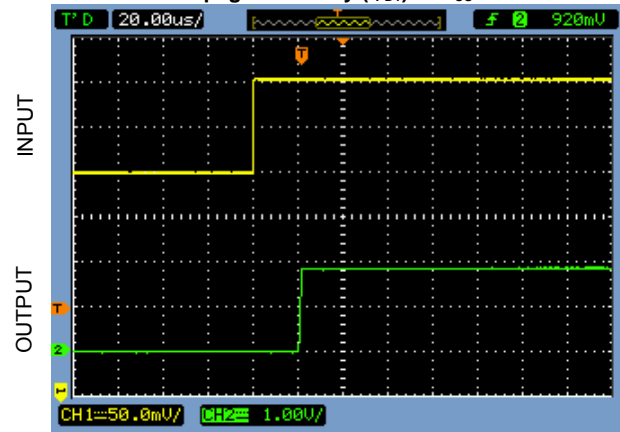

20µs/DIV

TSM9117/9119  
10kHz Transient Response at  $V_{CC} = +1.8V$

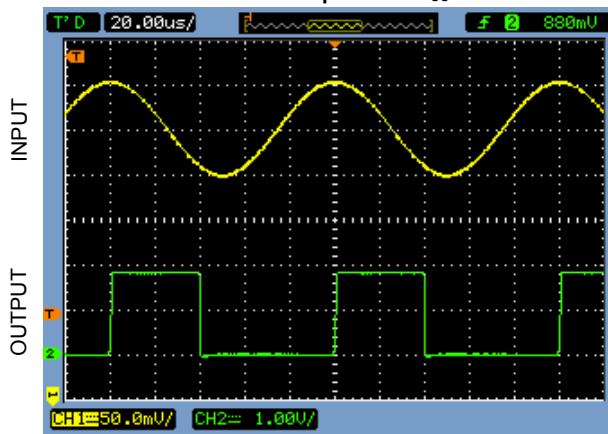

20µs/DIV

TSM9117/9119  
1kHz Transient Response at  $V_{CC} = +5V$

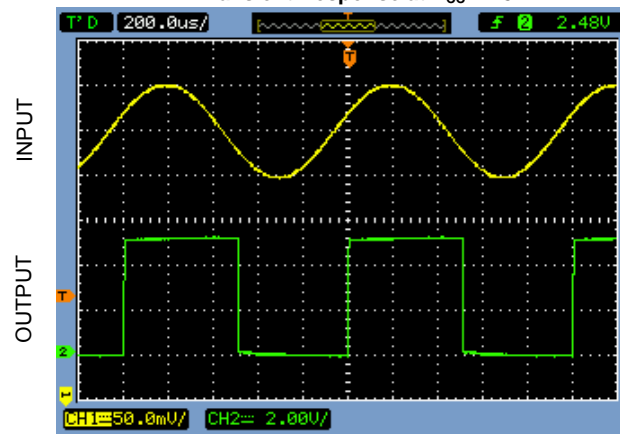

200µs/DIV

Power-Up/Power-Down Transient Response

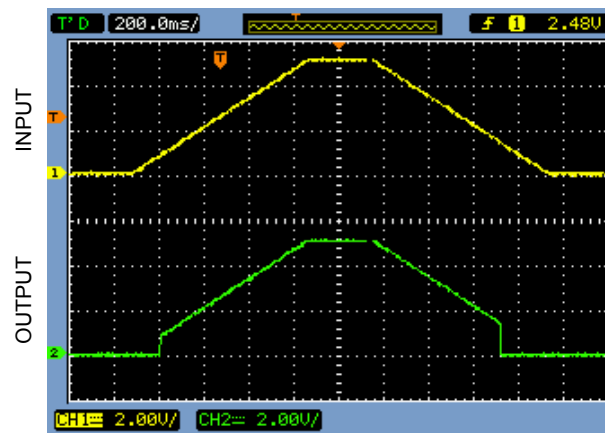

0.2s/DIV

## PIN FUNCTIONS

| TSM9117/TSM9118 |         | TSM9119/TSM9120 |         | NAME | FUNCTION   |
|-----------------|---------|-----------------|---------|------|--|
| SC70            | SO      | SC70            | SO      |      |  |
| 1               | 6       | 1               | 6       | OUT  | Comparator Output                                      |
| 2               | 4       | 2               | 4       | VEE  | Negative Supply Voltage                                |
| 3               | 3       | 3               | 3       | IN+  | Comparator Noninverting Input                          |
| 4               | 2       | —               | —       | REF  | 1.252V Reference Output and Comparator Inverting Input |
| 5               | 7       | 5               | 7       | VCC  | Positive Supply Voltage                                |
| —               | —       | 4               | 2       | IN-  | Comparator Inverting Input                             |
| —               | 1, 5, 8 | —               | 1, 5, 8 | NC   | No Connection. Not internally connected.               |

## BLOCK DIAGRAMS

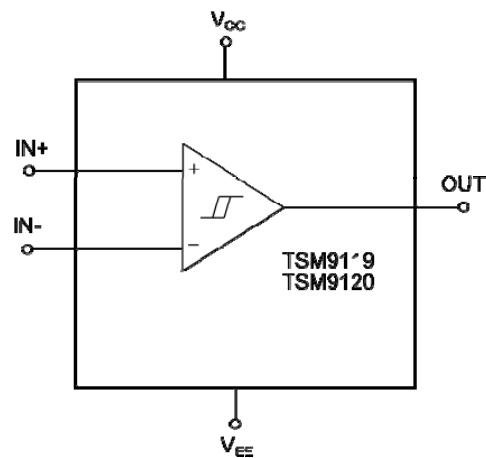
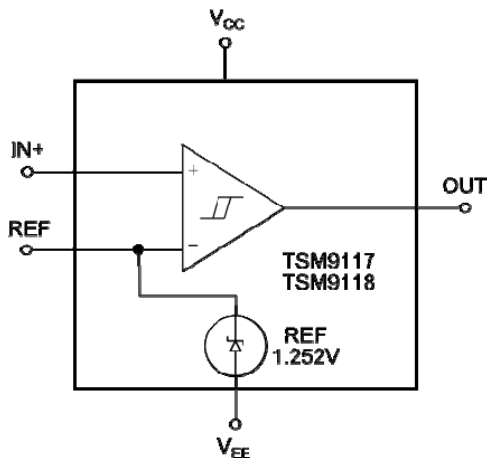

## DESCRIPTION OF OPERATION

Guaranteed to operate from +1.6V supplies, the TSM9117 and the TSM9118 comparators only draw 600nA supply current, feature a robust input stage that can tolerate input voltages 200mV beyond the power supply rails, and include an on-board +1.252V  $\pm 1.75\%$  voltage reference. The comparator-only TSM9119 and the TSM9120 have the same attributes and only draw a supply current of 350nA. To insure clean output switching behavior, all four analog comparators feature 4mV internal hysteresis. The TSM9117 and the TSM9119's push-pull output drivers were designed to minimize supply-current surges while driving  $\pm 5\text{mA}$  loads with rail-to-rail output swings. The open-drain output stage TSM9118 and TSM9120 can be connected to supply voltages above  $V_{CC}$  to an absolute maximum of 6V above  $V_{EE}$ . Where wired-OR logic connections are

needed, their open-drain output stages make it easy to use these analog comparators.

### Input Stage Circuitry

The robust design of the analog comparators' input stage can accommodate any differential input voltage from  $V_{EE} - 0.2\text{V}$  to  $V_{CC} + 0.2\text{V}$ . Input bias currents are typically  $\pm 0.15\text{nA}$  so long as the applied input voltage remains between the supply rails. ESD protection diodes - connected internally to the supply rails - protect comparator inputs against overvoltage conditions. However, if the applied input voltage exceeds either or both supply rails, an increase in input current can occur when these ESD protection diodes start to conduct.

## Output Stage Circuitry

Many conventional analog comparators can draw orders of magnitude higher supply current when switching. Because of this behavior, additional power supply bypass capacitance may be required to provide additional charge storage during switching. The design of the TSM9117–TSM9120’s rail-to-rail output stage implements a technique that virtually eliminates supply-current surges when output transitions occur. As shown on Page 5 of the Typical Operating Characteristics, the supply-current change as a function of output transition frequency exhibited by this analog comparator family is very small. Material benefits of this attribute to battery-power applications is the increase in operating time and in reducing the size of power-supply filter capacitors.

### TSM9117/9118’s Internal +1.252V $V_{REF}$

The TSM9117 and the TSM9118’s internal +1.252V voltage reference exhibits a typical temperature coefficient of 100ppm/°C over the full -40°C to +85°C temperature range. An equivalent circuit for the reference section is illustrated in Figure 1. Since the output impedance of the voltage reference

voltage reference is typically 200kΩ, preventing the reference from driving large loads. The reference is

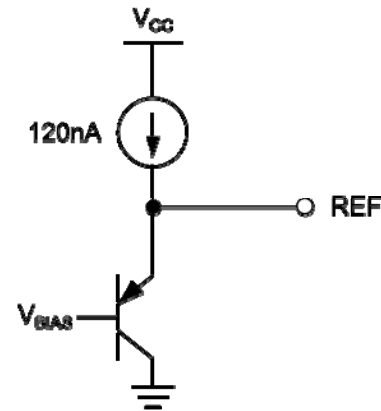

**Figure 1:** TSM9117 & TSM9118 Internal  $V_{REF}$  Output Equivalent Circuit

typically 200kΩ, its output can be bypassed with a low-leakage capacitor and is stable for any capacitive load. An external buffer – such as the TS1001 – can be used to buffer the voltage reference output for higher output current drive or to reduce reference output impedance.

## APPLICATIONS INFORMATION

### Low-Voltage, Low-Power Operation

Designed specifically for low-power applications, the TSM9117–TSM9120 comparators are an excellent choice. Under nominal conditions, approximate operating times for this analog comparator family is illustrated in Table 1 for a number of battery types and their charge capacities.

### Internal Hysteresis

As a result of circuit noise or unintended parasitic

feedback, many analog comparators often break into oscillation within their linear region of operation especially when the applied differential input voltage approaches 0V (zero volt). Externally-introduced hysteresis is a well-established technique to stabilizing analog comparator behavior and requires external components. As shown in Figure 2, adding comparator hysteresis creates two trip points:  $V_{THR}$  (for the rising input voltage) and  $V_{THF}$  (for the falling input voltage). The hysteresis band ( $V_{HB}$ ) is defined as the voltage difference between the two trip points. When a comparator’s input voltages are equal,

**Table 1: Battery Applications using the TSM9117- TSM9120**

| BATTERY TYPE                   | RECHARGEABLE | $V_{FRESH}$ (V) | $V_{END-OF-LIFE}$ (V) | CAPACITY, AA SIZE (mA-h) | TSM9117/TSM9118 OPERATING TIME (hrs) | TSM9119/TSM9120 OPERATING TIME (hrs) |
|--------------------------------|--------------|-----------------|-----------------------|--------------------------|--------------------------------------|--------------------------------------|
| Alkaline (2 Cells)             | No           | 3.0             | 1.8                   | 2000                     | $2.5 \times 10^6$                    | $5 \times 10^6$                      |
| Nickel-Cadmium (2 Cells)       | Yes          | 2.4             | 1.8                   | 750                      | 937,500                              | $1.875 \times 10^6$                  |
| Lithium-Ion (1 Cell)           | Yes          | 3.5             | 2.7                   | 1000                     | $1.25 \times 10^6$                   | $2.5 \times 10^6$                    |
| Nickel-Metal-Hydride (2 Cells) | Yes          | 2.4             | 1.8                   | 1000                     | $1.25 \times 10^6$                   | $2.5 \times 10^6$                    |

hysteresis effectively forces one comparator input to move quickly past the other input, moving the input out of the region where oscillation occurs. out of the region where oscillation occurs. Figure 2 illustrates the case in which an IN- input is a fixed voltage and an IN+ is varied. If the input signals were reversed, the figure would be the same with an inverted output. To save cost and external pcb area, an internal 4mV hysteresis circuit was added to the TSM9117-TSM9120.

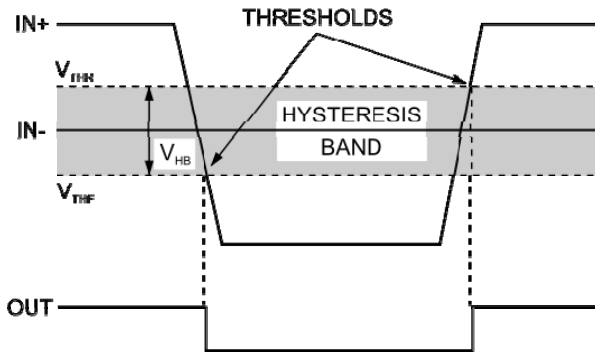

**Figure 2:** TSM9117-TSM9120 Threshold Hysteresis Band

### Adding Hysteresis to the TSM9117/TSM9119

The TSM9117/TSM9119 exhibit an internal hysteresis band ( $V_{HYSB}$ ) of 4mV. Additional hysteresis can be generated with three external resistors using positive feedback as shown in Figure 3. Unfortunately, this method also reduces the

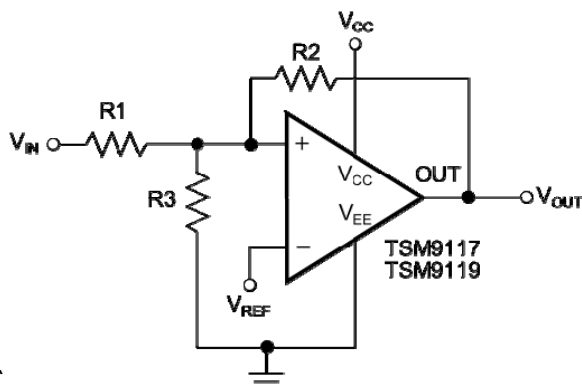

**Figure 3:** Using Three Resistors Introduces Additional Hysteresis in the TSM9117 & TSM9119.

hysteresis response time. Use the following procedure to calculate resistor values.

- 1) Setting R2. As the leakage current at the IN pin is less than 2nA, the current through R2 should be at least 0.2µA to minimize offset voltage errors caused by the input leakage current. The current through R2 at the trip point is  $(V_{REF} - V_{OUT})/R2$ . In solving for R2, there are two formulas – one each for the two possible output states:

$$R2 = V_{REF}/I_{R2}$$

or

$$R2 = (V_{CC} - V_{REF})/I_{R2}$$

From the results of the two formulae, the smaller of the two resulting resistor values is chosen. For example, when using the TSM9117 ( $V_{REF} = 1.252V$ ) at a  $V_{CC} = 3.3V$  and if  $I_{R2} = 0.2\mu A$  is chosen, then the formulae above produce two resistor values: 6.26MΩ and 10.24MΩ - the 6.2MΩ standard value for R2 is selected.

- 2) Next, the desired hysteresis band ( $V_{HYSB}$ ) is set. In this example,  $V_{HYSB}$  is set to 100mV.
- 3) Resistor R1 is calculated according to the following equation:

$$R1 = R2 \times (V_{HYSB}/V_{CC})$$

and substituting the values selected in 1) and 2) above yields:

$$R1 = 6.2M\Omega \times (100mV/3.3V) = 187.88k\Omega.$$

The 187kΩ standard value for R1 is chosen.

- 4) The trip point for  $V_{IN}$  rising ( $V_{THR}$ ) is chosen such that  $V_{THR} > V_{REF} \times (R1 + R2)/R2$  ( $V_{THF}$  is the trip point for  $V_{IN}$  falling). This is the threshold voltage at which the comparator switches its output from low to high as  $V_{IN}$  rises above the trip point. In this example,  $V_{THR}$  is set to 3V.
- 5) With the  $V_{THR}$  from Step 4 above, resistor R3 is then computed as follows:

$$R3 = 1/[V_{THR}/(V_{REF} \times R1) - (1/R1) - (1/R2)]$$

$$R3 = 1/[3V/(1.252V \times 187k\Omega) - (1/187k\Omega) - (1/6.2M\Omega)] = 136.9k\Omega$$

In this example, a 137kΩ, 1% standard value resistor is selected for R3.

- The last step is to verify the trip voltages and hysteresis band using the standard resistance values:

For  $V_{IN}$  rising:

$$V_{THR} = V_{REF} \times R1 \left[ \left( \frac{1}{R1} \right) + \left( \frac{1}{R2} \right) + \left( \frac{1}{R3} \right) \right] = 3V$$

and, for  $V_{IN}$  falling:

$$V_{THF} = V_{THR} - (R1 \times V_{CC}/R2) = 2.9V$$

and Hysteresis Band =  $V_{THR} - V_{THF} = 100mV$

### Adding Hysteresis to the TSM9118/TSM9120

The TSM9118/TSM9120 have a 4mV internal hysteresis band. Both products have open-drain outputs and require an external pullup resistor to  $V_{CC}$  as shown in Figure 4. Additional hysteresis can be

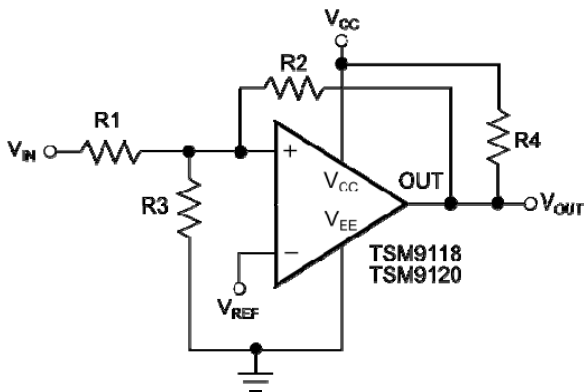

**Figure 4:** Using Four Resistors Introduces Additional Hysteresis in the TSM9118 & TSM9120.

generated using positive feedback; however, the formulae differ slightly from those of the TSM9117/TSM9119. The procedure to calculate the resistor values for the TSM9118/TSM9120 is as follows:

- As in the previous section, resistor R2 is chosen according to the formulae:

$$R2 = V_{REF}/0.2\mu A$$

or

$$R2 = (V_{CC} - V_{REF})/0.2\mu A - R4$$

where the smaller of the two resulting resistor values is the best starting value.

- As before, the desired hysteresis band ( $V_{HYSB}$ ) is set to 100mV.

- Next, resistor R1 is then computed according to the following equation:

$$R1 = (R2 + R4) \times (V_{HYSB}/V_{CC})$$

- The trip point for  $V_{IN}$  rising ( $V_{THR}$ ) is chosen (again, remember that  $V_{THF}$  is the trip point for  $V_{IN}$  falling). This is the threshold voltage at which the comparator switches its output from low to high as  $V_{IN}$  rises above the trip point.

- With the  $V_{THR}$  from Step 4 above, resistor R3 is computed as follows:

$$R3 = 1/[V_{THR}/(V_{REF} \times R1) - (1/R1) - (1/R2)]$$

- As before, the last step is to verify the trip voltages and hysteresis band with the standard resistor values used in the circuit:

For  $V_{IN}$  rising:

$$V_{THR} = V_{REF} \times R1 \times (1/R1 + 1/R2 + 1/R3)$$

and, for  $V_{IN}$  falling:

$$V_{THF} = V_{REF} \times R1 \times [1/R1 + 1/R3 + 1/(R2 + R4)] - [R1/(R2 + R4)] \times V_{CC}$$

and Hysteresis Band is given by  $V_{THR} - V_{THF}$

### PC Board Layout and Power-Supply Bypassing

While power-supply bypass capacitors are not typically required, it is good engineering practice to use 0.1μF bypass capacitors close to the device's power supply pins when the power supply impedance is high, the power supply leads are long, or there is excessive noise on the power supply traces. To reduce stray capacitance, it is also good engineering practice to make signal trace lengths as short as possible. Also recommended are a ground plane and surface mount resistors and capacitors.

## A Zero-Crossing Detector

To configure a zero-crossing detector using a TSM9119 is illustrated in Figure 5. In this example, the TSM9119's inverting input is connected to ground and its noninverting input is connected to a 100mV<sub>P-P</sub> signal source. The TSM9119's output changes state as the signal at the noninverting input crosses 0V.

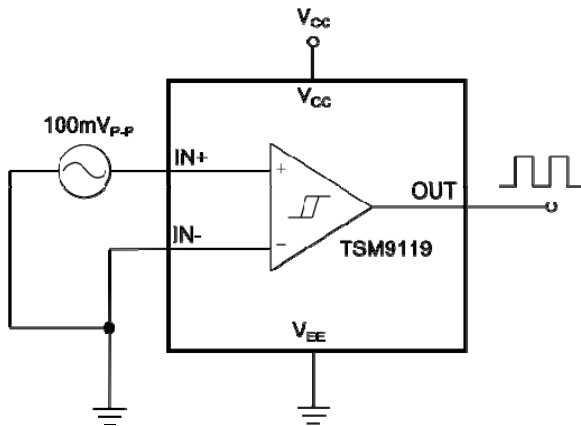

**Figure 5:** A Simple Zero-Crossing Detector

## A Logic-Level Translator

Logic-level translation between two different voltage systems is easy using the TSM9120 as shown in Figure 6. This application circuit converts 5V logic to

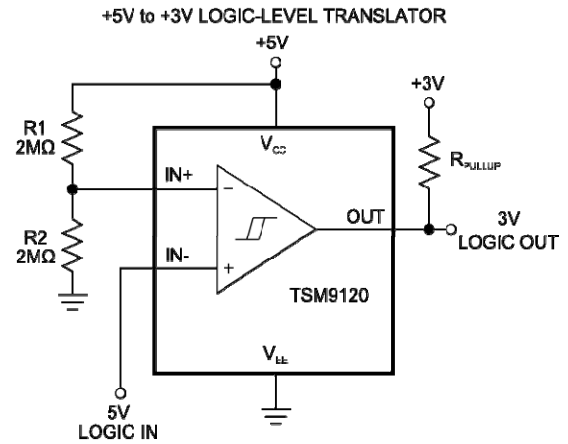

**Figure 6:** A 5V-to-3V Logic Level Translator

3V logic levels. In this case, the TSM9120 is powered by a +5V system and the external pullup resistor for the TSM9120's open-drain output is connected to a +3V system. This configuration allows the full 5V logic swing without creating overvoltage on the 3V logic inputs. For 3V to 5V logic-level translations, simply interchange the +3V supply voltage connection on the comparator's V<sub>CC</sub> and the +5V supply voltage to the external pullup resistor

# TSM9117-TSM9120



## PACKAGE OUTLINE DRAWING

### 5-Pin SC70 Package Outline Drawing

(N.B., Drawings are not to scale)

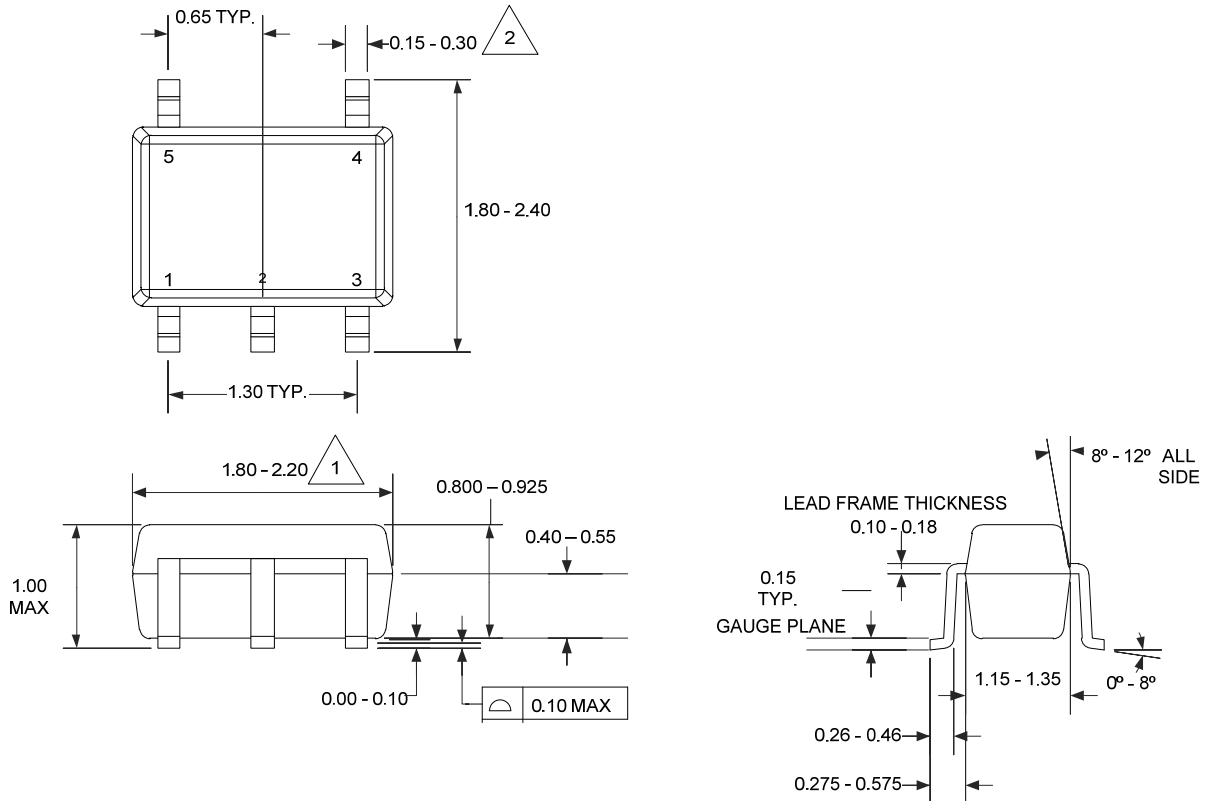

#### NOTES:

1 DOES NOT INCLUDE MOLD FLASH, PROTRUSIONS OR GATE BURRS.

2 DOES NOT INCLUDE INTER-LEAD FLASH OR PROTRUSIONS.

3. DIE IS FACING UP FOR MOLDING. DIE IS FACING DOWN FOR TRIM/FORM.

4 ALL SPECIFICATION COMPLY TO JEDEC SPEC MO-203 AA

5. CONTROLLING DIMENSIONS IN MILIMITERS.

6. ALL SPECIFICATIONS REFER TO JEDEC MO-203 AA

7. LEAD SPAN/STAND OFF HEIGHT/COPLANARITY ARE CONSIDERED AS SPECIAL CHARACTERISTIC



## PACKAGE OUTLINE DRAWING

### 8-Pin SOIC Package Outline Drawing

(N.B., Drawings are not to scale)

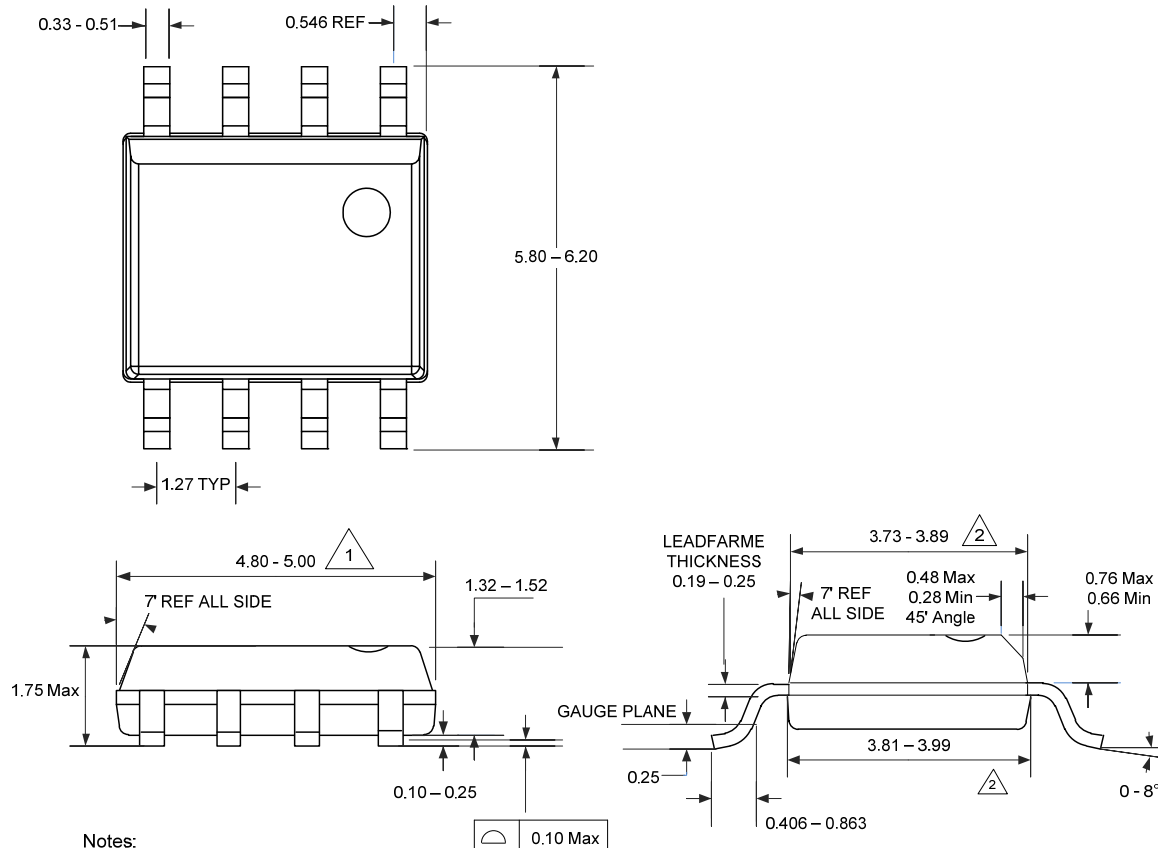

Notes:

1. Does not include mold flash, protrusions or gate burns. Mold flash, protrusions or gate burrs shall not exceed 0.15 mm per side.
2. Does not include inter-lead flash or protrusions. Inter-lead flash or protrusions shall not exceed 0.25 mm per side.
3. Lead span/stand off height/coplanarity are considered as special characteristic (s).
4. Controlling dimensions are in mm.
5. This part is compliant with JEDEC specification MS-012
6. Lead span/stand off height/coplanarity are considered as Special characteristic.

Information furnished by Touchstone Semiconductor is believed to be accurate and reliable. However, Touchstone Semiconductor does not assume any responsibility for its use nor for any infringements of patents or other rights of third parties that may result from its use, and all information provided by Touchstone Semiconductor and its suppliers is provided on an AS IS basis, WITHOUT WARRANTY OF ANY KIND. Touchstone Semiconductor reserves the right to change product specifications and product descriptions at any time without any advance notice. No license is granted by implication or otherwise under any patent or patent rights of Touchstone Semiconductor. Touchstone Semiconductor assumes no liability for applications assistance or customer product design. Customers are responsible for their products and applications using Touchstone Semiconductor components. To minimize the risk associated with customer products and applications, customers should provide adequate design and operating safeguards. Trademarks and registered trademarks are the property of their respective owners.