

NEC

User's Manual

IE-784915-R-EM1

I/O Emulation Board

EP-784915GF-R

Emulation Probe

μ PD784915 Subseries

μ PD784928 Subseries

μ PD784928Y Subseries

Document No. U10931EJ2V0UM00 (2nd edition)
Date Published October 1997 N

© NEC Corporation 1996
Printed in Japan

[MEMO]

This product is designed to be used in a commercial or industrial district. If it is used in a residential district or in an area in the vicinity of a residential district, radio and TV receivers in the district may be affected. Use this product correctly by carefully reading its User's Manual.

The information in this document is subject to change without notice.

No part of this document may be copied or reproduced in any form or by any means without the prior written consent of NEC Corporation. NEC Corporation assumes no responsibility for any errors which may appear in this document.

NEC Corporation does not assume any liability for infringement of patents, copyrights or other intellectual property rights of third parties by or arising from use of a device described herein or any other liability arising from use of such device. No license, either express, implied or otherwise, is granted under any patents, copyrights or other intellectual property rights of NEC Corporation or of others.

Regional Information

Some information contained in this document may vary from country to country. Before using any NEC product in your application, please contact the NEC office in your country to obtain a list of authorized representatives and distributors. They will verify:

- Device availability
- Ordering information
- Product release schedule
- Availability of related technical literature
- Development environment specifications (for example, specifications for third-party tools and components, host computers, power plugs, AC supply voltages, and so forth)
- Network requirements

In addition, trademarks, registered trademarks, export restrictions, and other legal issues may also vary from country to country.

NEC Electronics Inc. (U.S.)

Santa Clara, California
Tel: 800-366-9782
Fax: 800-729-9288

NEC Electronics (Germany) GmbH

Duesseldorf, Germany
Tel: 0211-65 03 02
Fax: 0211-65 03 490

NEC Electronics (UK) Ltd.

Milton Keynes, UK
Tel: 01908-691-133
Fax: 01908-670-290

NEC Electronics Italiana s.r.l.

Milano, Italy
Tel: 02-66 75 41
Fax: 02-66 75 42 99

NEC Electronics (Germany) GmbH

Benelux Office
Eindhoven, The Netherlands
Tel: 040-2445845
Fax: 040-2444580

NEC Electronics (France) S.A.

Velizy-Villacoublay, France
Tel: 01-30-67 58 00
Fax: 01-30-67 58 99

NEC Electronics (France) S.A.

Spain Office
Madrid, Spain
Tel: 01-504-2787
Fax: 01-504-2860

NEC Electronics (Germany) GmbH

Scandinavia Office
Taebly, Sweden
Tel: 08-63 80 820
Fax: 08-63 80 388

NEC Electronics Hong Kong Ltd.

Hong Kong
Tel: 2886-9318
Fax: 2886-9022/9044

NEC Electronics Hong Kong Ltd.

Seoul Branch
Seoul, Korea
Tel: 02-528-0303
Fax: 02-528-4411

NEC Electronics Singapore Pte. Ltd.

United Square, Singapore 1130
Tel: 253-8311
Fax: 250-3583

NEC Electronics Taiwan Ltd.

Taipei, Taiwan
Tel: 02-719-2377
Fax: 02-719-5951

NEC do Brasil S.A.

Sao Paulo-SP, Brasil
Tel: 011-889-1680
Fax: 011-889-1689

MAJOR REVISIONS IN THIS EDITION

Page	Contents
Throughout	μ PD784928 subseries and μ PD784928Y subseries added to the target devices.
p.61	VOLUME 2 EP-784915GF-R APPENDIX A EXTERNAL VIEW OF CONVERSION SOCKET Drawing of the NQPACK100RB added.

The mark ★ shows major revised points.

[MEMO]

PREFACE

Product outline

The IE-784915-R-EM1 is connected to the IE-784000-R-EM, inserted in the IE-784000-R, and used to debug the μ PD784915 subseries, μ PD784928 subseries, and μ PD784928Y subseries 16-bit single-chip microcontrollers.

The EP-784915GF-R is an emulation probe to connect the IE-784915-R-EM1 and a target system. The EP-784915GF-R is used in combination with the EV-9200GF-100 or NQPACK100RB.

Remark The NQPACK100RB is a product of Tokyo Eletech Corp. (03-5295-1661). When purchasing the product, consult your NEC distributor.

Intended Readership

This manual is intended for engineers who use the μ PD784915 subseries, μ PD784928 subseries, and μ PD784928Y subseries 16-bit single-chip microcontrollers and perform system debugging, using the IE-784000-R and IE-784000-R-EM in combination with the IE-784915-R-EM1. It is also intended for engineers who upgrade a system using other in-circuit emulators so that it has functions equivalent to those of the IE-784000-R. Therefore, the engineers who read this manual are assumed to be familiar with the functions and usage of the subseries used and have knowledge of debuggers.

Purpose

The purpose of this manual is to give readers an understanding of the method of connecting the IE-784915-R-EM1 to the IE-784000-R and IE-784000-R-EM, the setting method when debugging the μ PD784915 subseries, μ PD784928 subseries, and μ PD784928Y subseries, and the method of connecting the EP-784915GF-R with the IE-784915-R-EM1.

Organization

This manual consists of the following two parts.

VOLUME 1: IE-784915-R-EM1

- System configuration
- Function of external interface with IE-784000-R

VOLUME 2: EP-784915GF-R

- General description
- Connection method

Use the IE-784000-R manual as well.

Using This Information

VOLUME 1: IE-784915-R-EM1

To have a general understanding of the IE-784915-R-EM1 functions,
→ read according to the **TABLE OF CONTENTS**.

To understand the basic specifications,
→ read **CHAPTER 1 GENERAL DESCRIPTION**.

When looking up the setting method when the IE-784915-R-EM1 is connected with the IE-784000-R to debug the μ PD784915 subseries, μ PD784928 subseries, and μ PD784928Y subseries,
→ read **CHAPTER 2 INSTALLATION PROCEDURE**.

VOLUME 2: EP-784915GF-R

To have a general understanding of the EP-784915GF-R functions,
→ read according to the **TABLE OF CONTENTS**.

To understand the operating environment and configuration,
→ read **CHAPTER 1 GENERAL DESCRIPTION**.

To understand the specific connection method,
→ read **CHAPTER 2 CONNECTION**.

Terminology

The meaning of each term used in this manual is described in the table below.

Term	Meaning
Emulation device	General term of devices that perform emulation of target devices in the emulator Includes the emulation CPU.
Emulation CPU	CPU block which executes the program created by the user in the emulator
Target device	Device that is an emulation target (real chip)
Target program	Program that is a debugging target (program created by the user)
Target system	System that is a debugging target (system created by the user). Includes a target program and hardware created by the user. Refers to hardware only in a narrow sense.

Legend

- Note** : Explanation of items marked with **Note** in the text
- Caution** : Item to be especially noted
- Remark** : Supplementary information

TABLE OF CONTENTS

VOLUME 1 IE-784915-R-EM1

CHAPTER 1 GENERAL DESCRIPTION	13
1.1 Features	13
1.2 Product Configuration	13
1.3 Part Names	16
1.4 Target Device	17
1.5 Emulation Probe	17
1.6 Operating Precautions	17
CHAPTER 2 INSTALLATION PROCEDURE	19
2.1 Connection with IE-784000-R	19
2.2 Connection with Target System	23
2.3 When Target System is not Connected	23
CHAPTER 3 SETTING OF USER CLOCK	25
3.1 Setting of Operating Clock.....	25
3.2 Attaching Crystal Oscillator	26
CHAPTER 4 START-UP	29
CHAPTER 5 DIFFERENCES FROM TARGET DEVICE	31
APPENDIX A PRODUCT SPECIFICATIONS	39

VOLUME 2 EP-784915GF-R

CHAPTER 1 GENERAL DESCRIPTION 43

- 1.1 Operating Environment 43**
- 1.2 Configuration 43**

CHAPTER 2 CONNECTION 49

- 2.1 Outline of Connection Procedure 49**
 - 2.1.1 Connection of IE-784000-R-EM and IE-784915-R-EM1 49
 - 2.1.2 Connection of IE-784000-R and EP-784915GF-R 49
 - 2.1.3 Connection of EP-784915GF-R and target system 51
 - 2.1.4 Connection of external sense clips 54
- 2.2 Powering-On/Powering-Off Order 56**
- 2.3 Removing EP-784915GF-R from Target System 57**

APPENDIX A EXTERNAL VIEW OF CONVERSION SOCKET 59

- A.1 External View of EV-9200GF-100 and Recommended Board Mounting Pattern 59**
- ★ A.2 External View of NQPACK100RB 61**

**VOLUME 1: IE-784915-R-EM1
I/O EMULATION BOARD**

[MEMO]

CHAPTER 1 GENERAL DESCRIPTION

The IE-784915-R-EM1 is an I/O emulation board for the μ PD784915 subseries, μ PD784928 subseries, and μ PD784928Y subseries 16-bit single-chip microcontrollers.

- ★ It can be made compatible with any product in the μ PD784915 subseries, μ PD784928 subseries, or μ PD784928Y subseries just by changing the chip set board.

Combining the IE-784915-R-EM1 and an emulation probe (EP-784915GF-R) with the IE-784000-R and IE-784000-R-EM allows efficient debugging and operation verification of a system using the μ PD784915 subseries, μ PD784928 subseries, and μ PD784928Y subseries.

1.1 Features

The features of a combined system of the IE-784915-R-EM1 with IE-784000-R and IE-784000-R-EM are as follows.

- Allows emulation of the μ PD784915 subseries, μ PD784928 subseries, and μ PD784928Y subseries peripheral functions (such as I/O port)
- Supply of CPU operating clock
- Combination with a separately available emulation probe (EP-784915GF-R) and connection of a chip set board to the tip of the EP-784915GF-R allow debugging with characteristics similar to those of the real chip.

1.2 Product Configuration

The IE-784915-R-EM1 has the following product configuration. Check the items included.

- ★
 - IE-784915-R-EM1 : 1
 - Chip set board : 2
(For the μ PD784915 subseries: 1, μ PD784928/784928Y subseries: 1)
 - User's Manual (this manual) : 1

Caution The chip set board is provided with a dedicated device (peripheral emulation device) to perform emulation of peripheral functions (I/O port, etc.) of the target device.

Figure 1-1. List of IE-784915-R-EM1 Product Configuration (1/3)

(1) IE-784915-R-EM1

Front

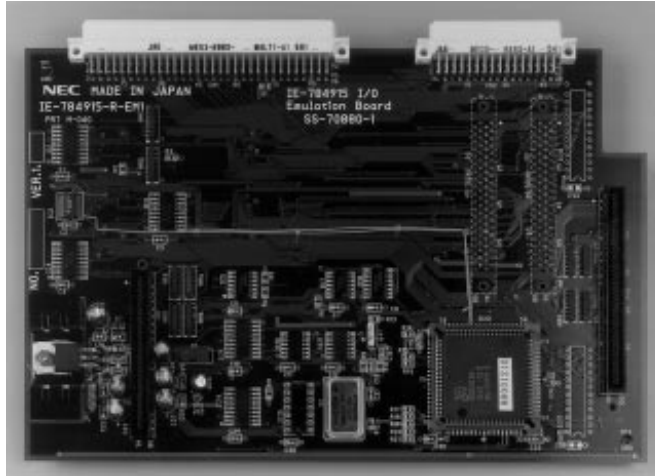

Back

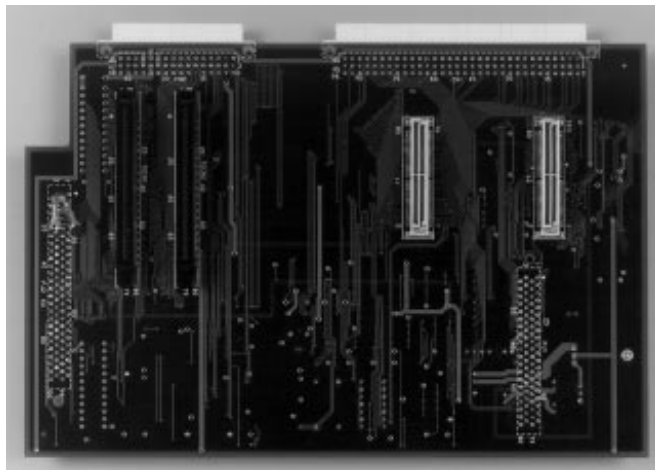

Figure 1-1. List of IE-784915-R-EM1 Product Configuration (2/3)

(2) Chip set board

The photos below show the chip set board of the μ PD784915 subseries. It has the same appearance as that of the μ PD784928 and 784928Y subseries. Please use the μ PD784915 subseries as a reference.

Side to be connected to emulation probe**Side to be connected to dummy board**

Figure 1-1. List of IE-784915-R-EM1 Product Configuration (3/3)

(3) User's Manual (this manual)

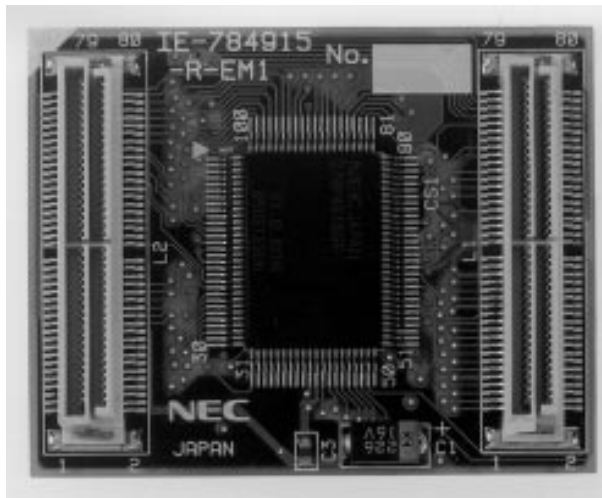
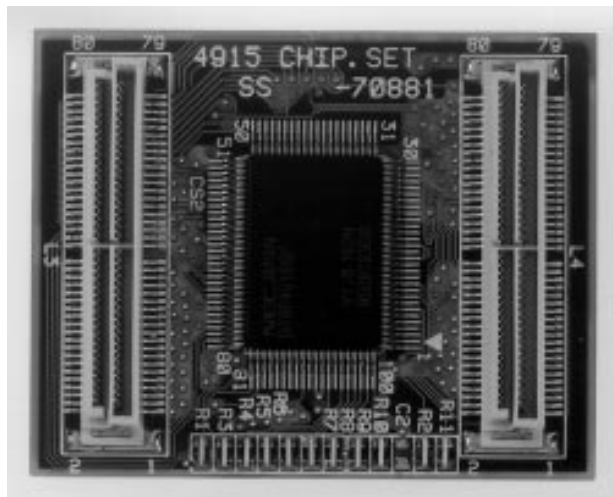
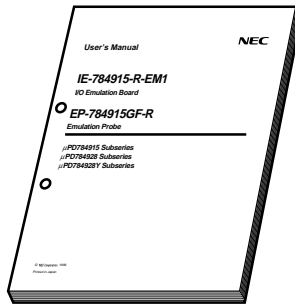

1.3 Part Names

Table 1-1 shows names of connectors and other parts.

Table 1-1. IE-784915-R-EM1 Part Names

Name	Function
CN1 CN2	Emulation probe (EP-784915GF-R) connector
PJ1 PJ2	Emulation board (EP-784000-R-EM) connector
TGCN1 TGCN2	Unused
L1 L2	Chip set board Connector

★ 1.4 Target Device

The following products are the target devices that can be emulated by the IE-784000-R and IE-784000-R-EM in combination with the IE-784915-R-EM1.

<μPD784915 subseries>	<μPD784928 subseries>	<μPD784928Y subseries>
• μPD784915	• μPD784927	• μPD784927Y
• μPD78P4916	• μPD784928	• μPD784928Y
	• μPD78F4928	• μPD78F4928Y

Remark The μPD784928 subseries and 784928Y subseries are under development.

1.5 Emulation Probe

Use of the IE-784915-R-EM1 connected to the target system always requires an emulation probe. The emulation probe is available separately.

Part Number	Target Package
EP-784915GF-R	100-pin plastic QFP (14 × 20 mm)

Caution Two types of probe tip board (dummy board) are provided: LCC type and QFP type. See VOLUME 2 EP-784915GF-R for details.

1.6 Operating Precautions

- (1) Be sure to turn off the power of the IE-784000-R and target system before connection of the IE-784915-R-EM1 with the IE-784000-R and IE-784000-R-EM and its removal.
- (2) When performing emulation of the target device by the IE-784915-R-EM1 in combination with the IE-784000-R and IE-784000-R-EM, note that there are partial differences in pin characteristics from the real chip (see **CHAPTER 5 DIFFERENCES FROM TARGET DEVICE**).
- (3) Correctly attach the IE-784915-R-EM1 to the IE-784000-R-EM.
- (4) Correctly attach the IE-784000-R-EM to the IE-784000-R main unit.
- (5) Correctly connect the chip set board.
 - When an emulation probe is used,
 - connect the chip set board to the tip of the emulation probe.
 - When an emulation probe is not used,
 - connect the chip select board to connectors L1 and L2 of the IE-784915-R-EM1.

Caution Do not simultaneously connect the chip set board to both the tip of the emulation probe and the IE-784915-R-EM1.

[MEMO]

CHAPTER 2 INSTALLATION PROCEDURE

2.1 Connection with IE-784000-R

Figure 2-1 shows an installation schematic of the IE-784000-R.

Figure 2-1. Installation Schematic of IE-784000-R

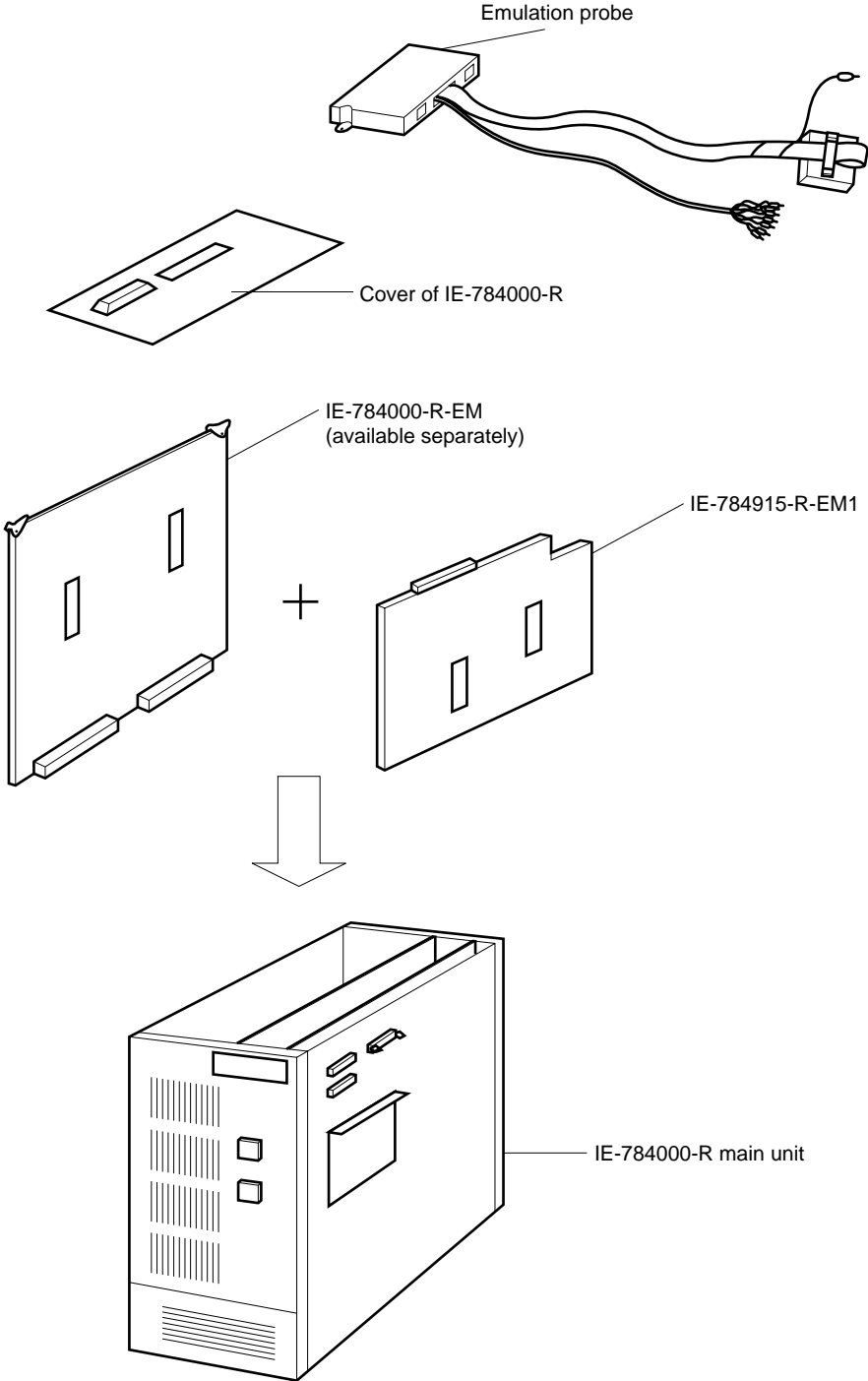

The IE-784915-R-EM1 is connected to the IE-784000-R and IE-784000-R-EM according the following procedure.

<1> Connection of chip set board

Caution When used with an emulation probe connected, do not connect the chip set board to the IE-784915-R-EM1.

Connect the chip set board to L1 and L2 on the IE-784915-R-EM1.

Figure 2-2. Connection of Chip Set Board

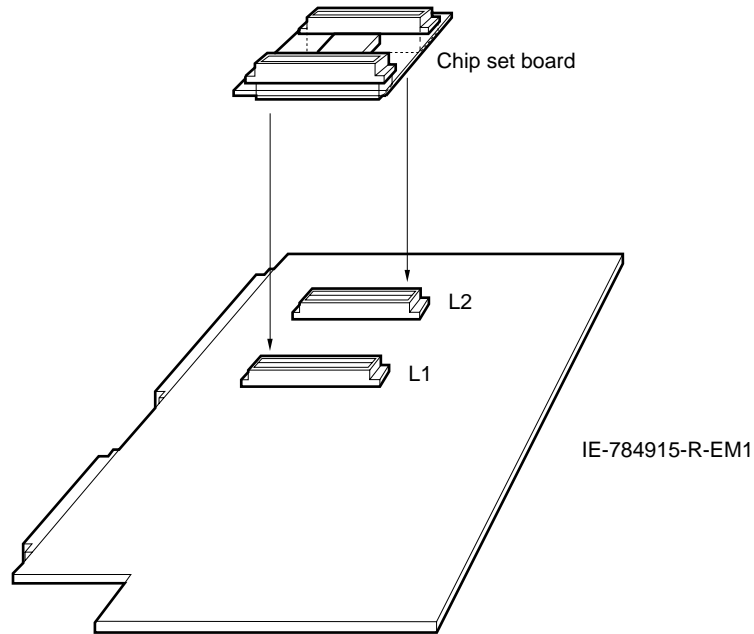

<2> Setting of user clock

Perform the setting with reference to **CHAPTER 3 SETTING OF USER CLOCK.**

- <3> Mounting IE-784915-R-EM1 onto IE-784000-R-EM
 Connect connectors PJ1 and PJ2 on the IE-784000-R-EM with connectors PJ1 and PJ2 on the IE-784915-R-EM1.

Figure 2-3. Connection of IE-784915-R-EM1 and IE-784000-R-EM

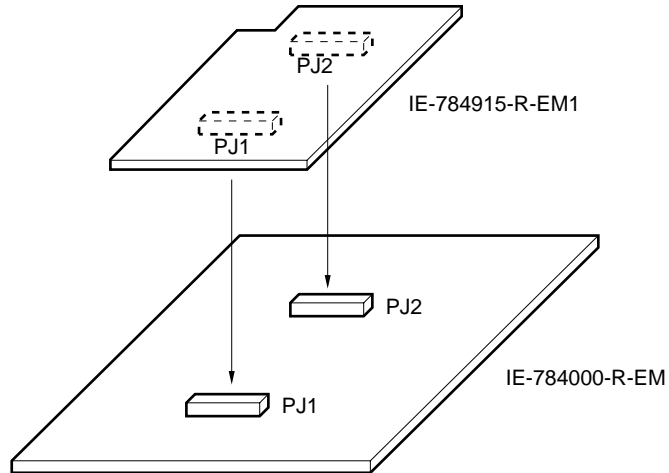

- <4> Removal of top cover
 Remove 6 screws on the top surface of the unit and remove the top cover as shown in Figure 2-4.

Figure 2-4. Removal of Top Cover

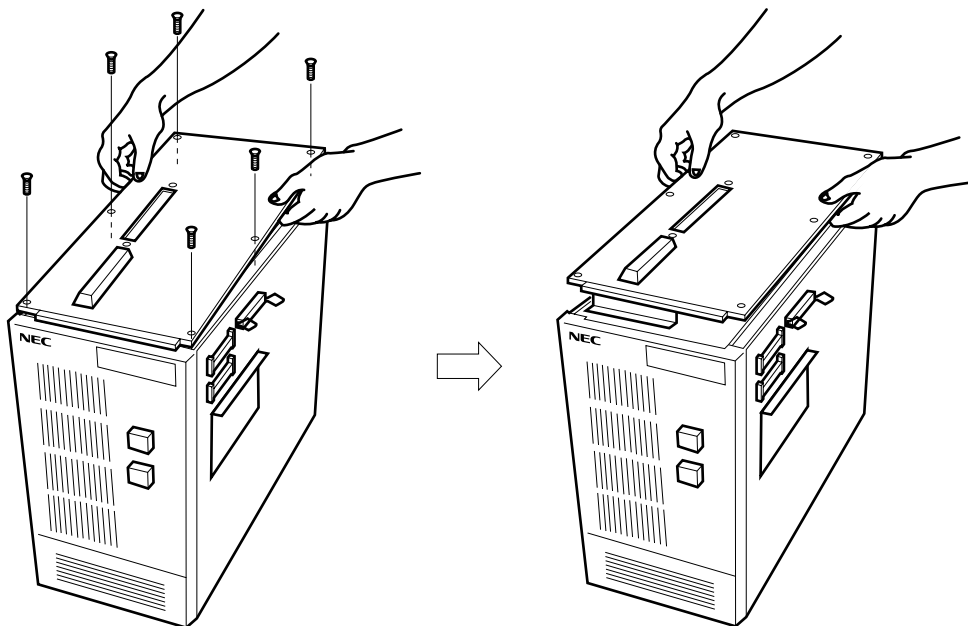

<5> Removal of rubber of top cover

After removing the top cover, remove the rubber.

<6> Insert the IE-784000-R-EM + IE-784915-R-EM1 into the 2nd slot and 3rd slot, put the top cover, and replace the screws.

Figure 2-5. Insertion of IE-784000-R-EM in IE-784000-R

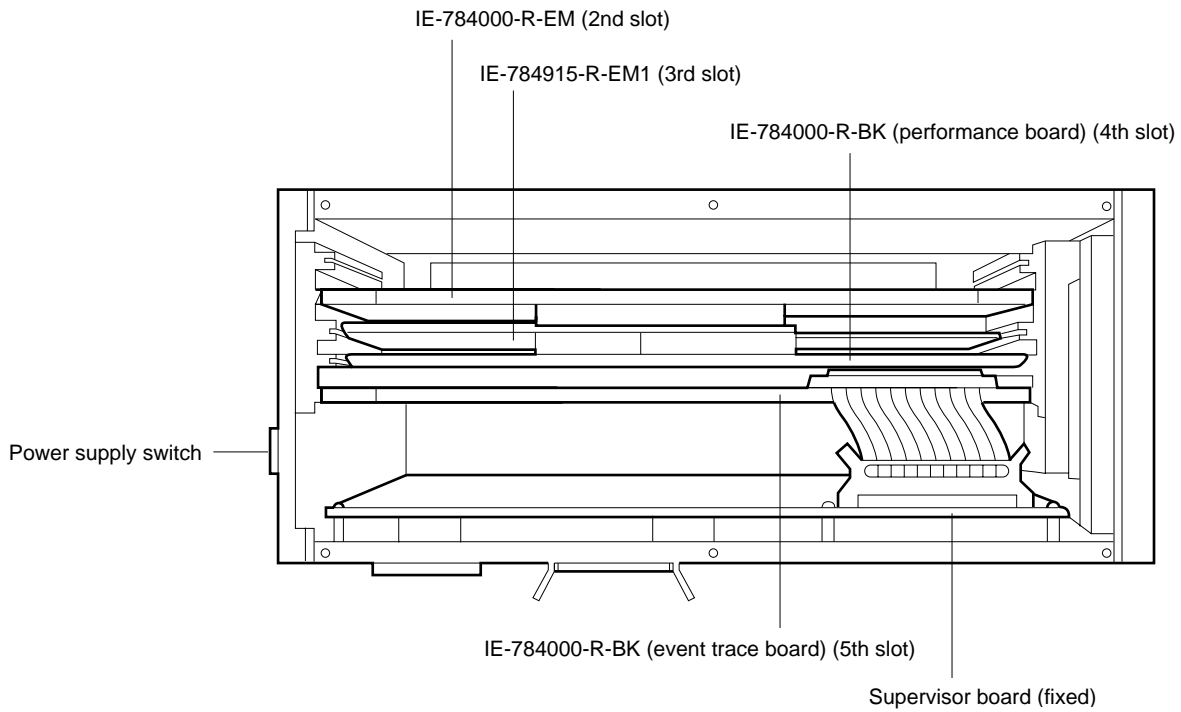

2.2 Connection with Target System

Connection of the IE-784000-R and the target system is performed using a separately available emulation probe (EP-784915GF-R). See **2.1.3 Connection of EP-784915GF-R and target system** of **VOLUME 2: EP-784915GF-R** for details.

2.3 When Target System is not Connected

★ Even if the target system is not connected, the IE-784000-R can still be used. In this case, connect the chip set board that contains the μ PD78P4916, μ PD78F4928, or μ PD78F4928Y (emulation chip) to connectors L1 and L2 of the IE-784915-R-EM1 to start the IE-784000-R. See **2.1 Connection with IE-784000-R** for details.

[MEMO]

CHAPTER 3 SETTING OF USER CLOCK

In the IE-784000-R, a fixed clock (16 MHz) on the IE-784915-R-EM1 is supplied to the emulation device unless the clock setting is changed.

Operating the emulation device with an oscillation clock on the target system or an arbitrary clock requires the setting of the clock setting socket (IC15) and selection of an external clock in the configuration dialog on the integrated debugger (ID78K4).

See the **ID78K/IV Integrated Debugger User's Manual** for the setting method using the integrated debugger and this chapter for operating with an arbitrary clock.

3.1 Setting of Operating Clock

The following operating clocks can be set in the IE-784000-R.

(1) Operation with fixed clock on IE-784915-R-EM1

When an internal clock is selected by the debugger, a fixed clock (16 MHz) on the emulation board is supplied to the emulation device.

This mode is set after the power of the IE-784000-R is turned on. This mode remains unchanged unless an external clock is selected.

(2) Operation with arbitrary clock on IE-784915-R-EM1

An arbitrary clock mounted on the clock setting socket (IC15) is supplied to the emulation device by mounting a crystal oscillator with the same frequency as the clock supplied to the target device on the clock setting socket on the IE-784915-R-EM1 and selecting an external clock by the integrated debugger (ID78K4).

See **3.2 Attaching Crystal Oscillator** for details.

Caution It is not possible to supply the clock from the oscillation clock on the target system to the emulation device. When operating at a frequency other than 16 MHz, use the method in (2) to supply the clock at the frequency actually used.

3.2 Attaching Crystal Oscillator

- <1> Prepare the IE-784915-R-EM1.
- <2> Attach a crystal oscillator (MAX. 16 MHz) to the clock setting socket (IC15) on the IE-784915-R-EM1.

Figure 3-1. Mounting Position on IE-784915-R-EM1

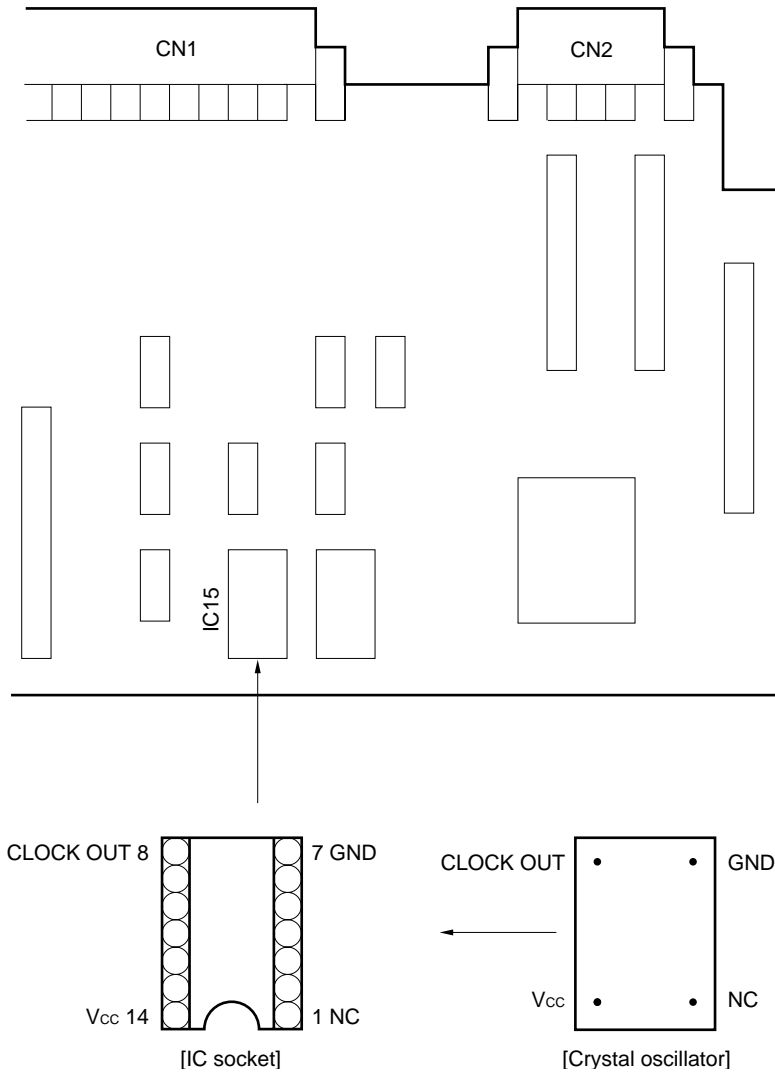

When an external clock is selected by the integrated debugger (ID78K4), the following circuit is configured by which a clock is supplied from the crystal oscillator to the emulation device in the IE-784000-R-EM.

Figure 3-2. Clock Supply of IE-784915-R-EM1

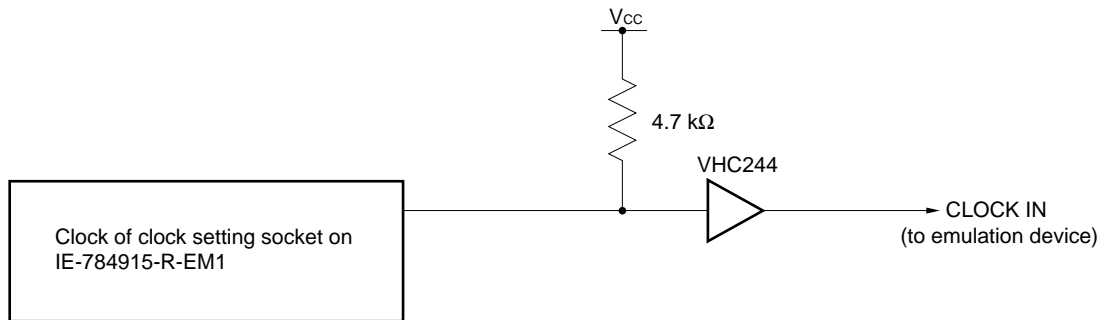

[MEMO]

CHAPTER 4 START-UP

For the start-up method, see the **ID78K/IV Integrated Debugger User's Manual** after the connection with the host machine is completed.

If the start-up does not work out, check problems using this manual or the IE-784000-R User's Manual.

[MEMO]

CHAPTER 5 DIFFERENCES FROM TARGET DEVICE

Since this IE performs emulation using the emulation CPU and peripheral simulation device, the IE pin characteristics are partly different from the pin characteristics of the target device.

(1) When chip set board is connected to emulation probe

Figure 5-1. Equivalent Circuit Diagram of Port Pin Emulation Circuit (1/3)

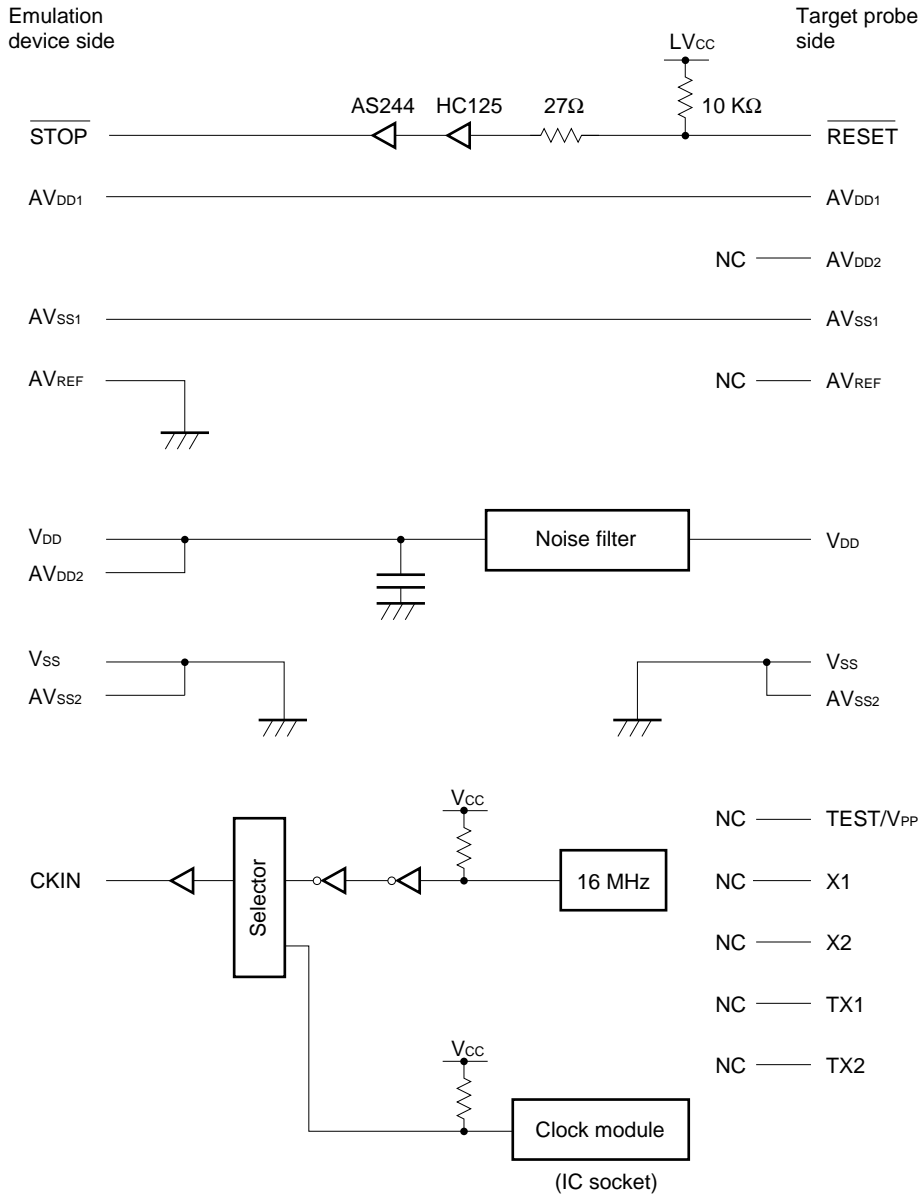

Caution If an external clock is selected in the configuration setting of the ID78K4, the clock frequency of the crystal oscillator mounted on the IC socket is selected.

Figure 5-1. Equivalent Circuit Diagram of Port Pin Emulation Circuit (2/3)

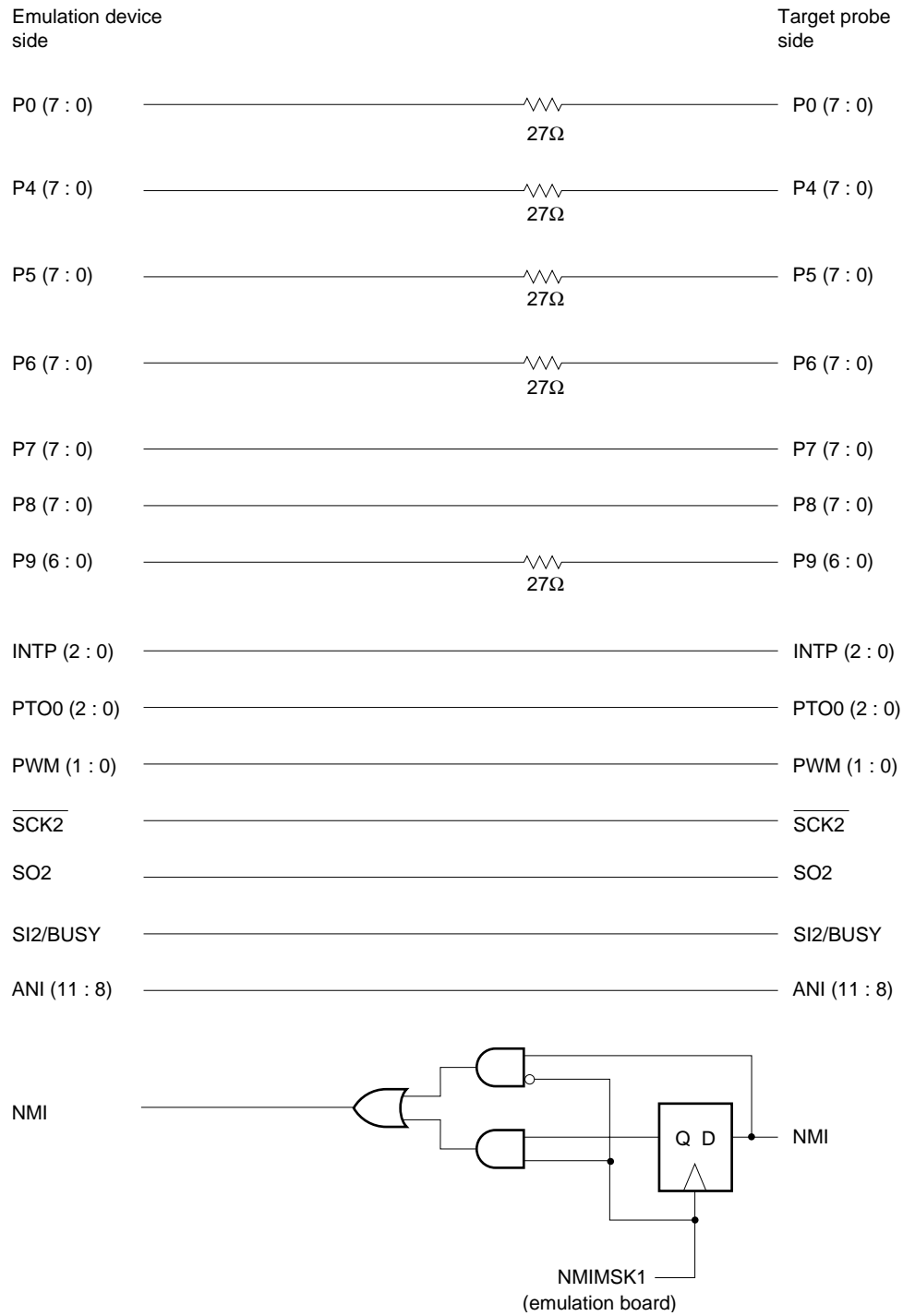
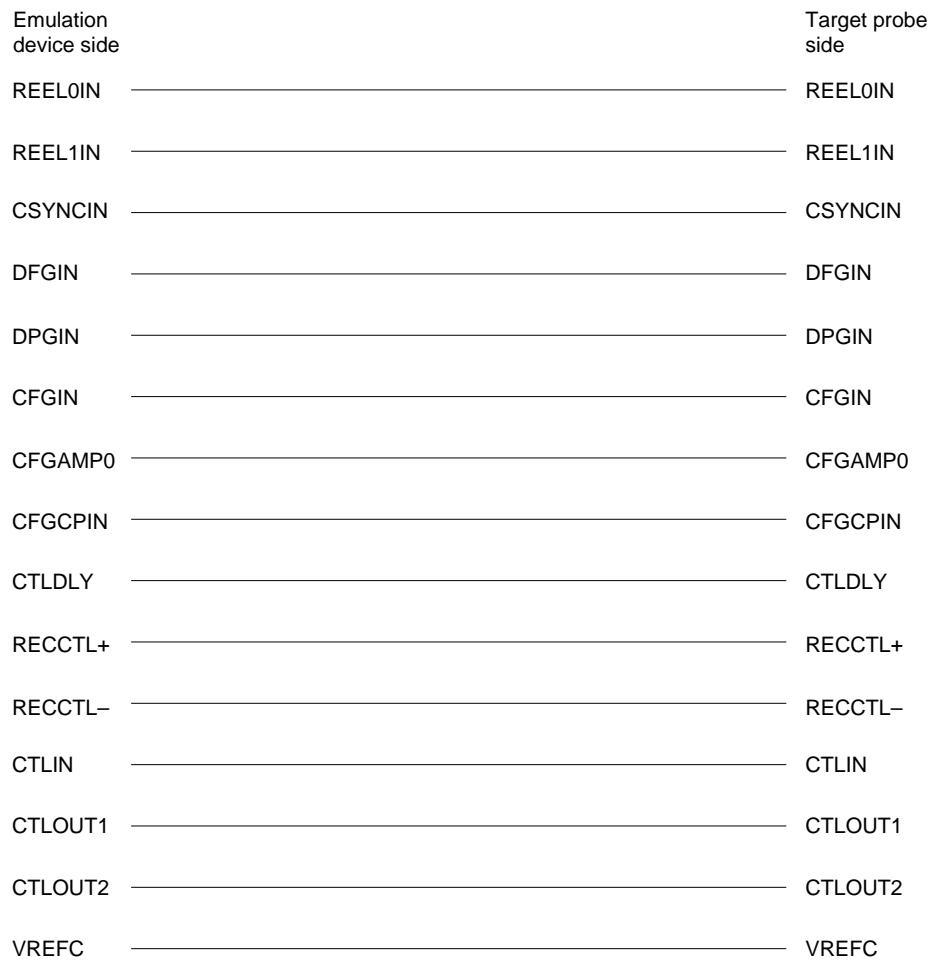

Figure 5-1. Equivalent Circuit Diagram of Port Pin Emulation Circuit (3/3)

(2) When chip set board is connected to IE-784915-R-EM1

Figure 5-2. Equivalent Circuit Diagram of Port Pin Emulation Circuit (1/3)

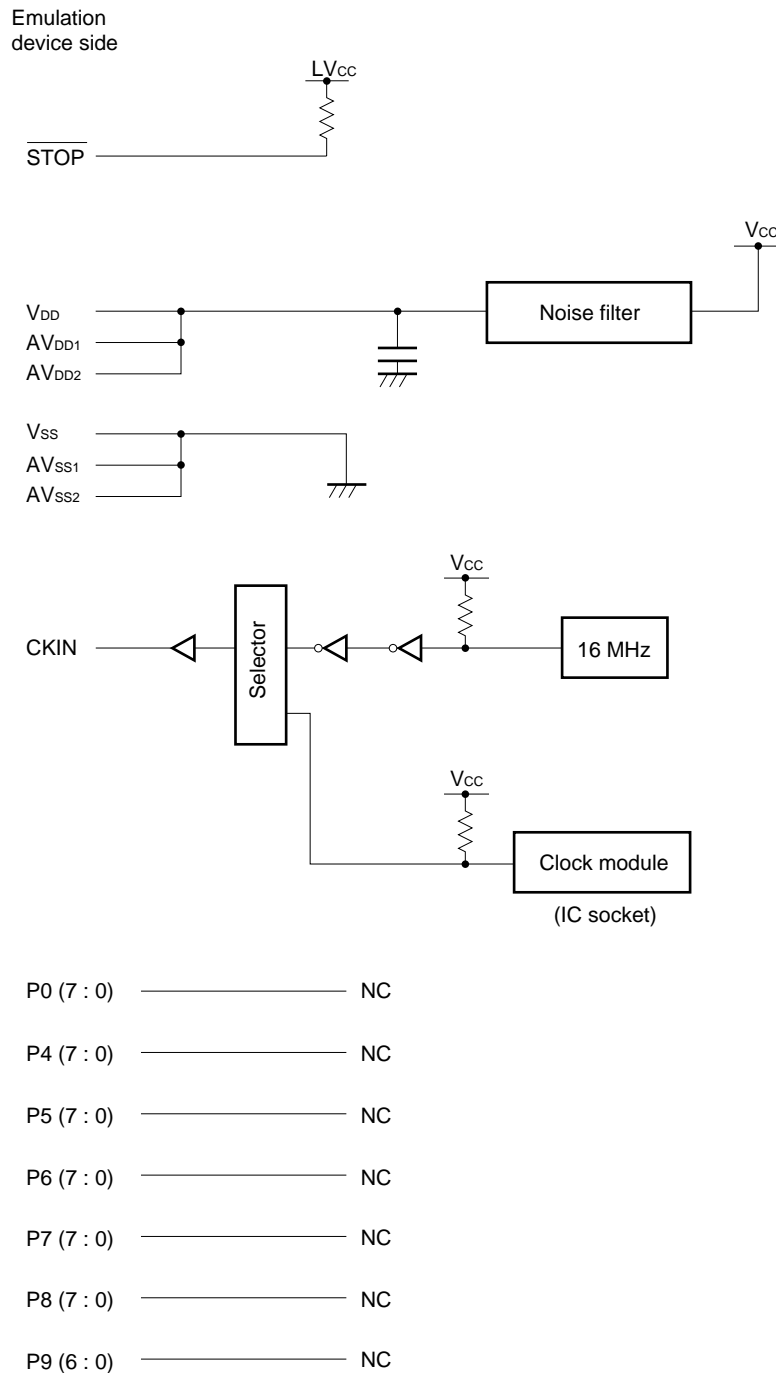

Figure 5-2. Equivalent Circuit Diagram of Port Pin Emulation Circuit (2/3)

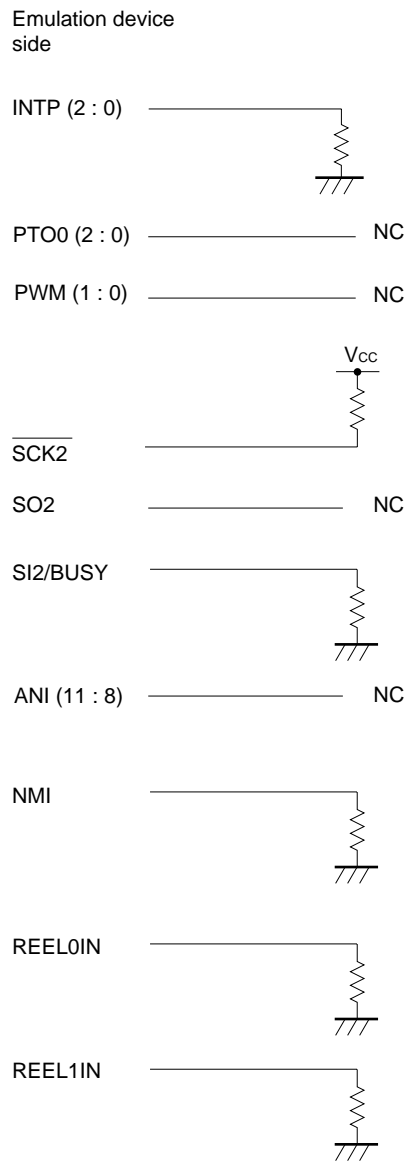
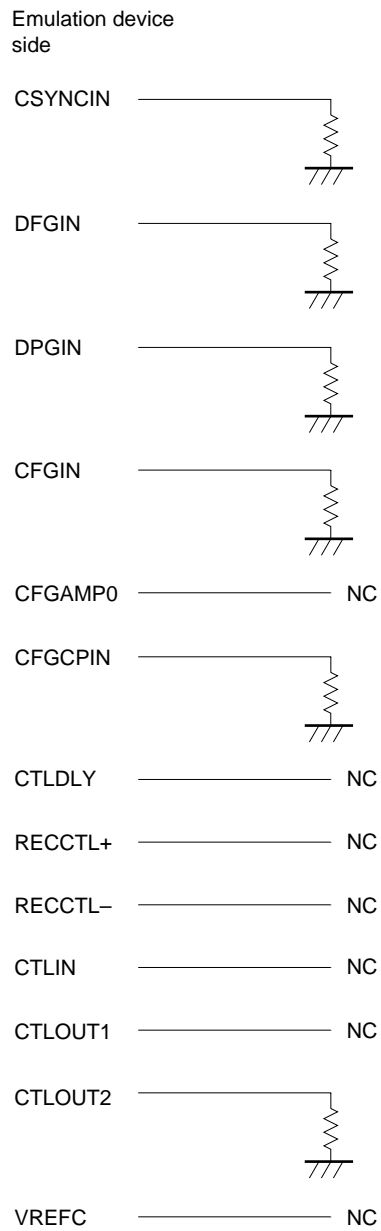

Figure 5-2. Equivalent Circuit Diagram of Port Pin Emulation Circuit (3/3)



Caution When the chip set board is connected with the IE-784915-R-EM1, power supply V_{DD} from the target is connected with LV_{cc} .

[MEMO]

APPENDIX A PRODUCT SPECIFICATIONS

Product name : IE-784915-R-EM1
Operating temperature : 10 to 40 °C (however, there should be no condensation.)
Humidity : 10 to 80% (however, there should be no condensation.)
Storage temperature : -15 to +45 °C (however, there should be no condensation.)
Power supply : +3.0 V to +5.5 V (supplied from IE-784000-R)
Printed circuit board size : 210 × 140 mm
Connectors:

Name	Function
CN1 CN2	Emulation probe (EP-784915GF-R) connector
PJ1 PJ2	Emulation board (IP-784000-R-EM) connector
TGCN1 TGCN2	Unused
L1 L2	Chip set board connector

[MEMO]

**VOLUME 2: EP-784915GF-R
EMULATION PROBE**

[MEMO]

CHAPTER 1 GENERAL DESCRIPTION

This chapter explains an outline of the EP-784915GF-R.

1.1 Operating Environment

The EP-784915GF-R is a probe set to connect the IE-784915-R-EM1 with the target system.

Connection by means of the EP-784915GF-R prepares a debugging environment for the microcontroller and allows you to perform integrated debugging of hardware and software of the target system using the μ PD784915 subseries, μ PD784928 subseries, and μ PD784928Y subseries.

★ It can be made compatible with any product in the μ PD784915 subseries, μ PD784928 subseries, or μ PD784928Y subseries just by changing the chip set board.

For the specific connection method, see **CHAPTER 2 CONNECTION**.

Figure 1-1. Connection of IE-784000-R and Target System

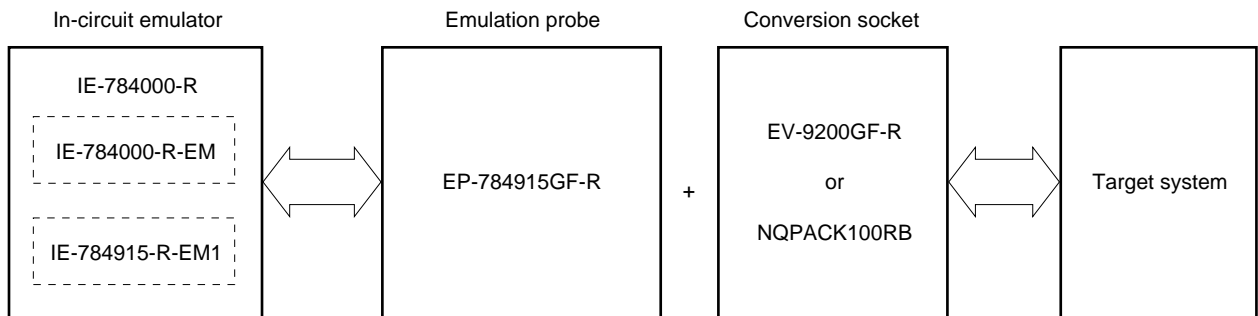

1.2 Configuration

The EP-784915GF-R consists of the following three parts.

- Cables
- Chip set board
- Dummy board (LCC type or QFP type can be selected)

Caution The EP-784915GF-R does not come with the chip set board. Use the one provided for the EP-784915-R-EM1.

Figure 1-2. EP-784915GF-R Configuration

<1> LCC type

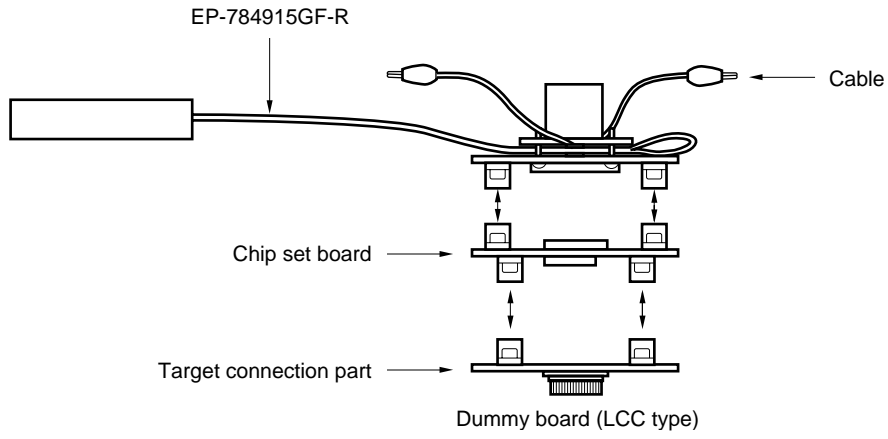

<2> QFP

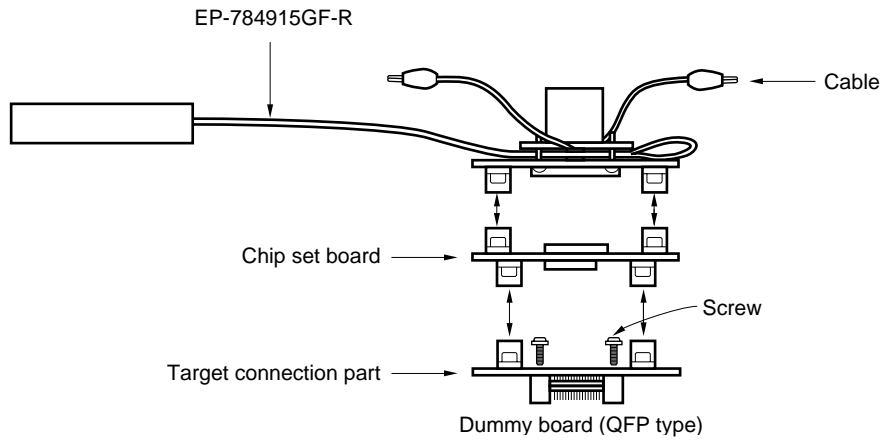

<1> Cables

The cables are used to connect CN1 and CN2 of the EP-784915-R-EM1 with the chip set board. The cables come with earth clips and external sense clips connected.

• Earth clips

Connect them to GND of the target system.

They allow the GND potential of the IE-784000-R to become the same as that of the target system making them resistant to static electricity and noise.

• External sense clips

8 sense clips are provided.

They are used to examine the voltage level of the IC pin mounted on the target system.

Figure 1-3. Emulation Probe (EP-784915GF-R)

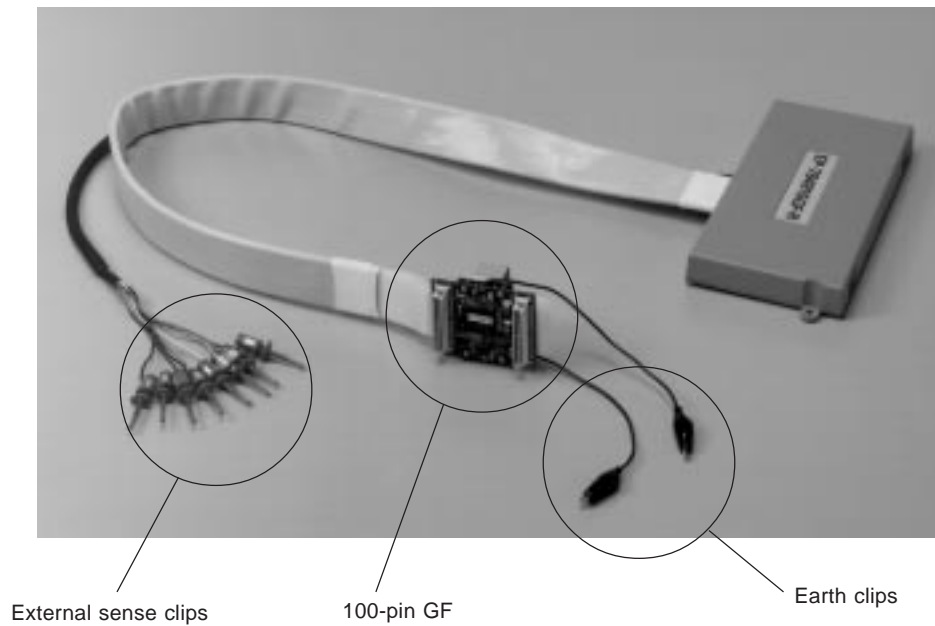

★ <2> **Chip set board**

This is a board on which the μ PD78P4916GF, μ PD78F4928GF, or μ PD78F4928YGF are mounted to perform emulation of peripheral functions.

Two chip set boards are attached to the IE-784915-R-EM1; one is for the μ PD784915 subseries, and other is for the μ PD784928 and 784928Y subseries. The emulation probe can be made compatible with any product in the μ PD784915 subseries, μ PD784928 subseries, or μ PD784928Y subseries just by changing the chip set board.

<3> **Dummy board**

This comprises the connection with the target system and two types are available: LCC type and QFP type. The LCC type and QFP type have different sockets connected to the target (see **Table 1-1**).

★ **Table 1-1. LCC Type and QFP Type Sockets**

	LCC Type	QFP Type
Socket on target side	EV-9200GF-100	NQPACK100RB
Features	–	μ PD78P4916GF, μ PD78F4928GF, or μ PD78F4928YGF mountable on socket (top cover is necessary)

Figure 1-4. Dummy Board

(1) LCC type

- Side to be connected to chip set board
- Side to be connected to target system

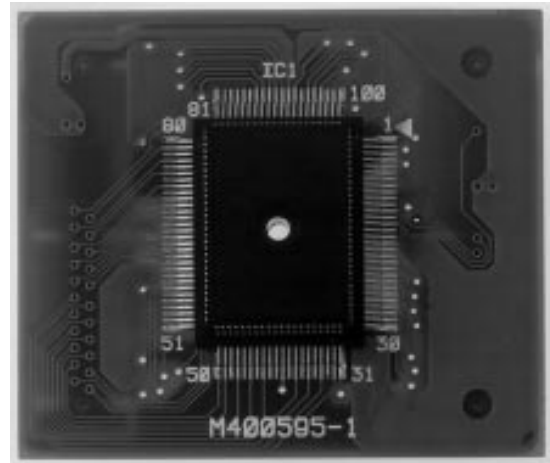
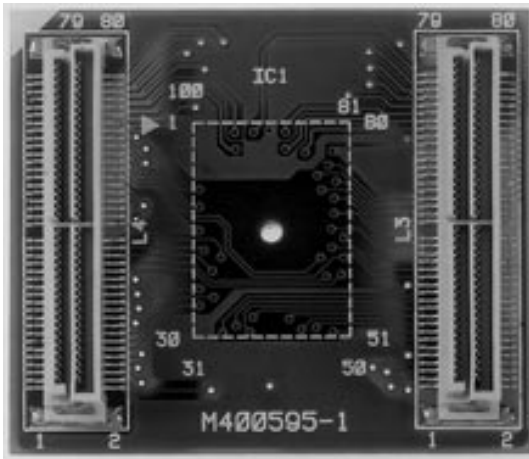

(2) QFP type

- Side to be connected to chip set board
- Side to be connected to target system

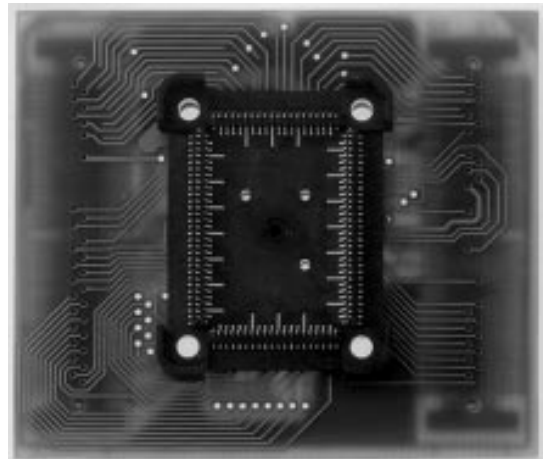
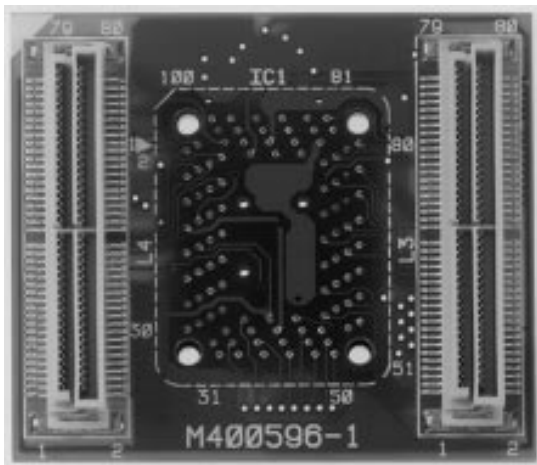

[MEMO]

CHAPTER 2 CONNECTION

This chapter explains the method of connecting the EP-784915GF-R, powering-on/powering-off procedure, and the method of removing the emulation probe from the target system.

2.1 Outline of Connection Procedure

- (1) Connection of emulation board and I/O emulation board
- (2) Connection of in-circuit emulator and emulation probe
- (3) Connection of emulation probe and target system
- (4) Connection of external sense clips (when external sense clips are used)
- (5) Powering-on

Details of the connection procedure are given below.

2.1.1 Connection of IE-784000-R-EM and IE-784915-R-EM1

- (1) Turn off the power of the IE-784000-R.
- (2) Remove the cover of the IE-784000-R.
- (3) Connect the IE-784915-R-EM1 to the IE-784000-R-EM.
- (4) Insert the IE-784000-R-EM and IE-784915-R-EM1 in the IE-784000-R.
- (5) Put the cover on the IE-784000-R.

2.1.2 Connection of IE-784000-R and EP-784915GF-R

- (1) Connect the EP-784915GF-R to the emulation probe connection DIN connectors (CN1 and CN2 of the IE-784915-R-EM1) on the IE-784000-R.
- (2) After the connection, be sure to fix the EP-784915GF-R and IE-784000-R with fitting screws.

Figure 2-1. Example of Connection of IE-784000-R Main Unit and EP-784915GF-R

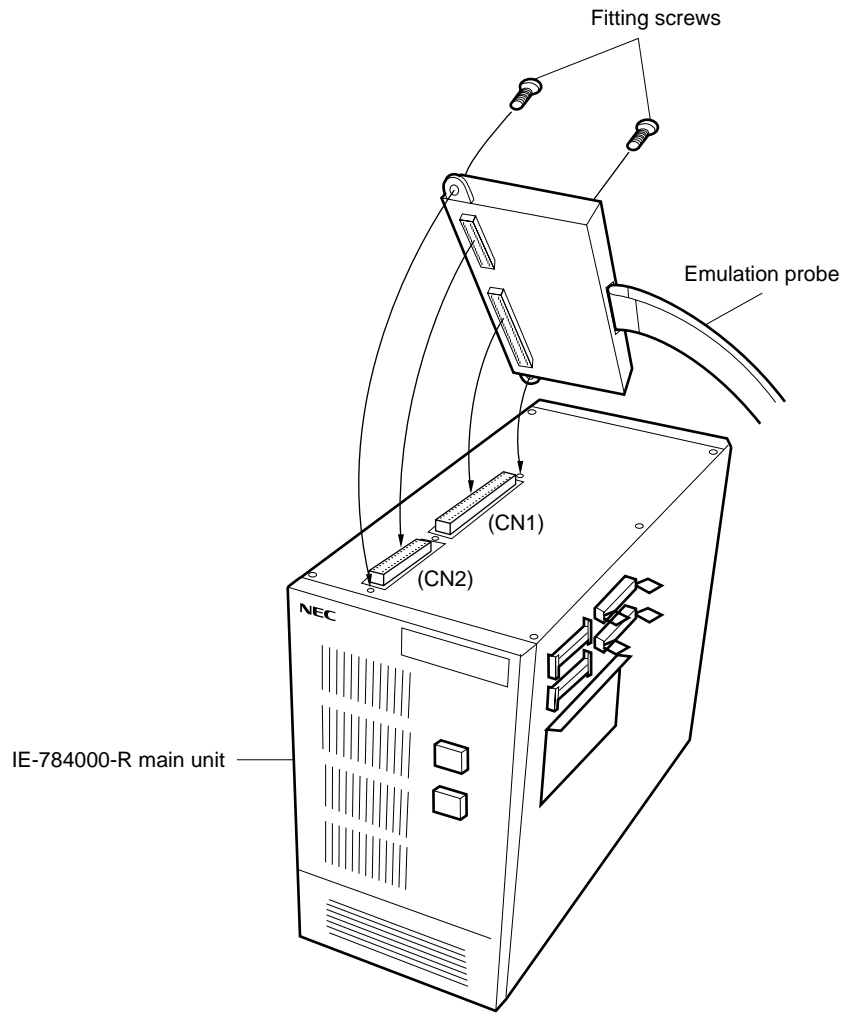

Caution The connection locations vary depending on the I/O emulation board. See the IE-784000-R User's Manual.

2.1.3 Connection of EP-784915GF-R and target system

The emulation probe and target system are connected in the following order.

Cautions 1. Before connecting the EP-784915GF-R with the target system, be sure to connect the earth clips first. Without the earth clips, the IE-784000-R may be destroyed by static electricity, etc.

2. Pay attention to inverse insertion of pins when making the connection. Erroneous connection may destroy the IE-784000-R.

(1) Turn off the power of the target system.

- ★ (2) Solder the conversion socket (EV-9200GF-100 or NQPACK100RB) attached to the IE-78495-R-EM1 to the target system.
- (3) Connect the earth clips of the EP-784915GF-R to GND of the target system.
- ★ (4) Insert the EP-784915GF-R while aligning the 100-pin GF at the tip of the EP-784915GF-R and pin 1 of the conversion socket (EV-9200GF-100 or NQPACK100RB) soldered to the target system in (2).

Figure 2-2. Example of Connection of EP-784915GF-R and Target System (LCC Type)

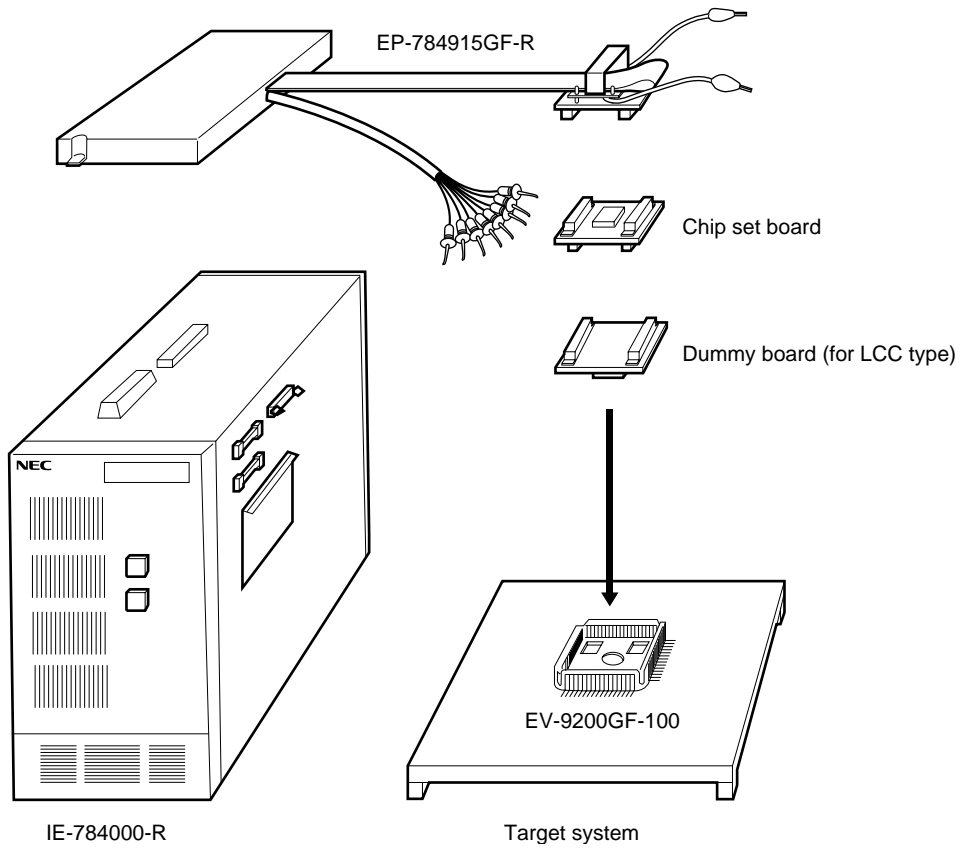

- <1> Connect the chip set board and dummy board.
- <2> Connect the EP-784915GF-R and <1>.
- <3> Connect <1> + <2> with the target system.

Figure 2-3. Example of Connection of EP-784915GF-R and Target System (QFP Type)

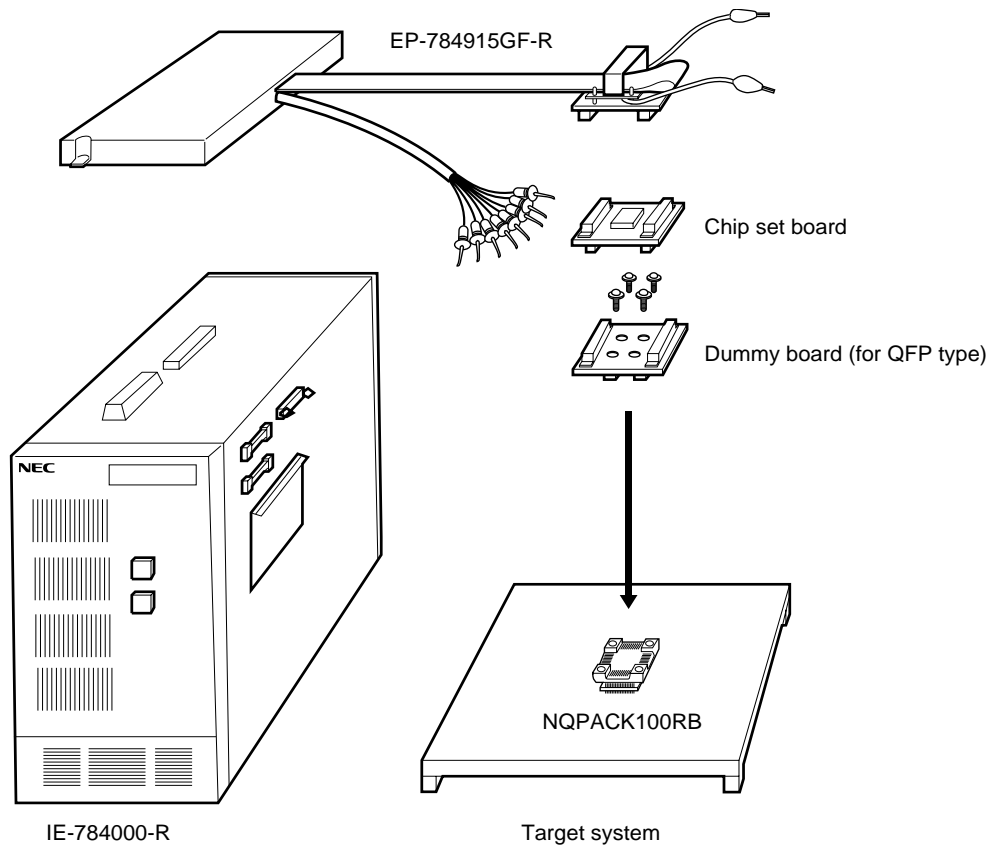

- <1> Connect the dummy board and target system and then fix them with screws.
- <2> Connect the EP-784915GF-R and the chip set board.
- <3> Connect <1> and <2>.

2.1.4 Connection of external sense clips

The EP-784915GF-R is provided with 8 external sense clips that can trace signals of hardware on the target system in real-time.

Since the external sense clips are directly connected to the HCT244 input buffer in the IE-784000-R, they are TTL-level inputs.

Normally, there are 8 external sense clip input signal lines, but the signal line of external sense clip 1 can be used as an outgoing trigger output signal line when an event occurs by setting the OUT command of the IE-784000-R (see the **IE-784000-R User's Manual** for details).

- Cautions**
- 1. Connect the external sense clips only to the TTL-level signal lines. If connected to signal lines other than the TTL-level signal lines, they cannot detect high/low levels accurately, or the sensor in the IE-784000-R may be destroyed depending on the voltage level.**
 - 2. When external sense clip 1 is used as an external trigger output, ensure that external sense clip 1 is not connected with the signal output line. Erroneous connection may cause malfunction.**

When using the external sense clips, connect them in the following order.

- (1) Turn off the power of the target system and IE-784000-R, in that order.
- (2) Attach the IC clips (sold separately) to any IC to be traced on the target system.
- (3) Connect the external sense clips to the IC clips attached.
- (4) Turn on the power of the IE-784000-R and target system, in that order.

Figure 2-4. Connection of External Sense Clip

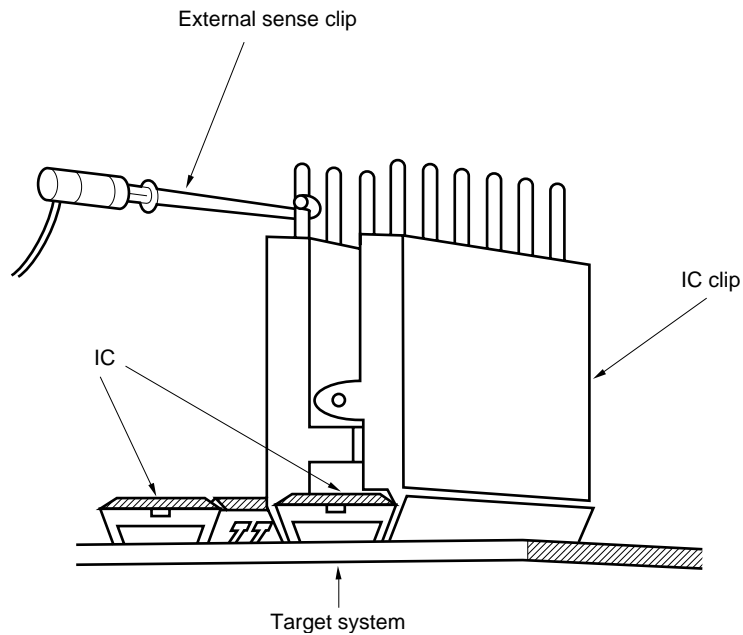

Remark When connecting the external clips, use the IC clips wherever possible. This will prevent mis-connection and improve operability.

2.2 Powering-On/Powering-Off Order

After connection of the emulation probe and target system is completed, turn on the power. The powering-on/powering-off order is as follows.

Caution Be sure to observe the powering-on/powering-off order. Failing to observe it may destroy the IE-784000-R.

<Powering-on order>

- (1) Turn on the power of the IE-784000-R.
- (2) Turn on the power of the target system.

<Powering-off order>

- (1) Turn off the power of the target system.
- (2) Turn off the power of the IE-784000-R.

2.3 Removing EP-784915GF-R from Target System

Remove the EP-784915GF-R from the target system in the following order.

(1) LCC type

- <1> Turn off the power of the target system.
- <2> Turn off the power of the IE-784000-R.
- <3> Remove the EP-784915GF-R + chip set board + dummy board from the target system.

(2) QFP type

- <1> Turn off the power of the target system.
- <2> Turn off the power of the IE-784000-R.
- <3> Remove the EP-784915GF-R + chip set board from the dummy board + target system.

[MEMO]

APPENDIX A EXTERNAL VIEW OF CONVERSION SOCKET

A.1 External View of EV-9200GF-100 and Recommended Board Mounting Pattern

Figure A-1. External View of EV-9200GF-100 (Reference)

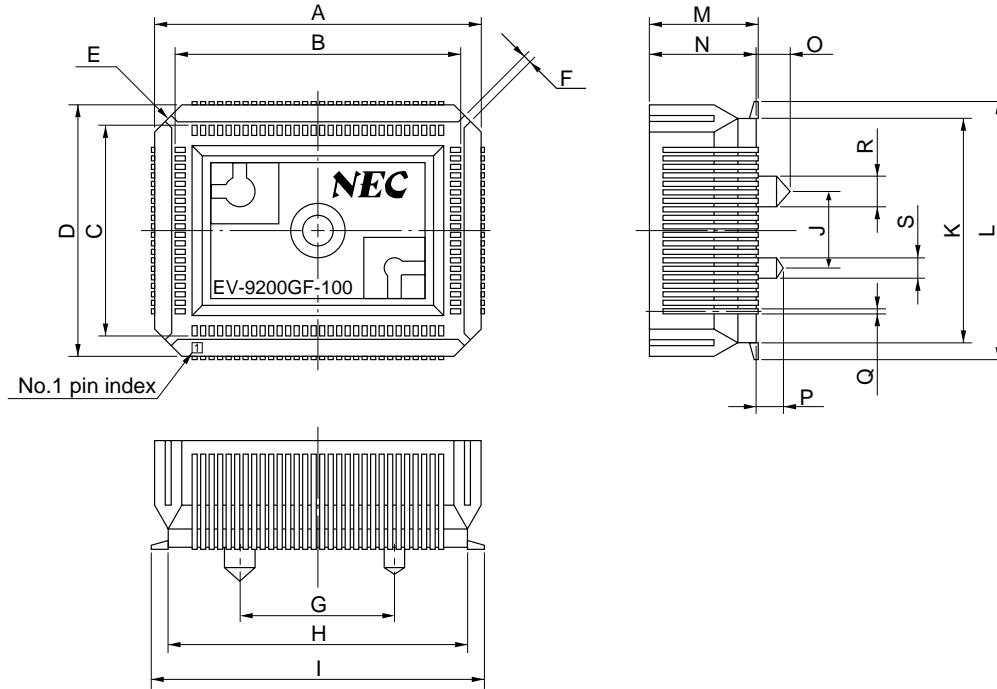

EV-9200GF-100-G0E

ITEM	MILLIMETERS	INCHES
A	24.6	0.969
B	21	0.827
C	15	0.591
D	18.6	0.732
E	4-C 2	4-C 0.079
F	0.8	0.031
G	12.0	0.472
H	22.6	0.89
I	25.3	0.996
J	6.0	0.236
K	16.6	0.654
L	19.3	0.76
M	8.2	0.323
N	8.0	0.315
O	2.5	0.098
P	2.0	0.079
Q	0.35	0.014
R	φ2.3	φ0.091
S	φ1.5	φ0.059

Figure A-2. Recommended Board Mounting Pattern of EV-9200GF-100 (Reference)

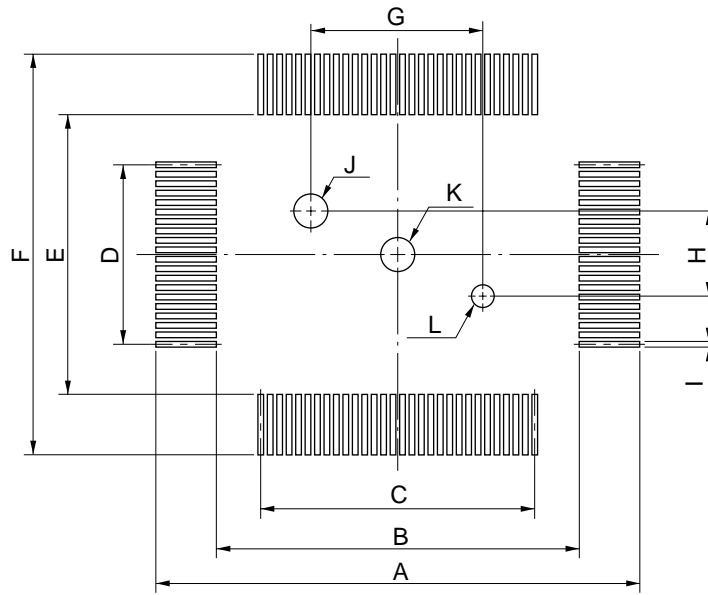

EV-9200GF-100-P1E

ITEM	MILLIMETERS	INCHES
A	26.3	1.035
B	21.6	0.85
C	$0.65 \pm 0.02 \times 29 = 18.85 \pm 0.05$	$0.026^{+0.001}_{-0.002} \times 1.142 = 0.742^{+0.002}_{-0.002}$
D	$0.65 \pm 0.02 \times 19 = 12.35 \pm 0.05$	$0.026^{+0.001}_{-0.002} \times 0.748 = 0.486^{+0.003}_{-0.002}$
E	15.6	0.614
F	20.3	0.799
G	12 ± 0.05	$0.472^{+0.003}_{-0.002}$
H	6 ± 0.05	$0.236^{+0.003}_{-0.002}$
I	0.35 ± 0.02	$0.014^{+0.001}_{-0.001}$
J	$\phi 2.36 \pm 0.03$	$\phi 0.093^{+0.001}_{-0.002}$
K	$\phi 2.3$	$\phi 0.091$
L	$\phi 1.57 \pm 0.03$	$\phi 0.062^{+0.001}_{-0.002}$

Caution Dimensions of mount pad for EV-9200 and that for target device (QFP) may be different in some parts. For the recommended mount pad dimensions for QFP, refer to "SEMICONDUCTOR DEVICE MOUNTING TECHNOLOGY MANUAL" (C10535E).

★ A.2 External View of NQPACK100RB

Figure A-3. External View of NQPACK100RB (Target connection side) (Reference)

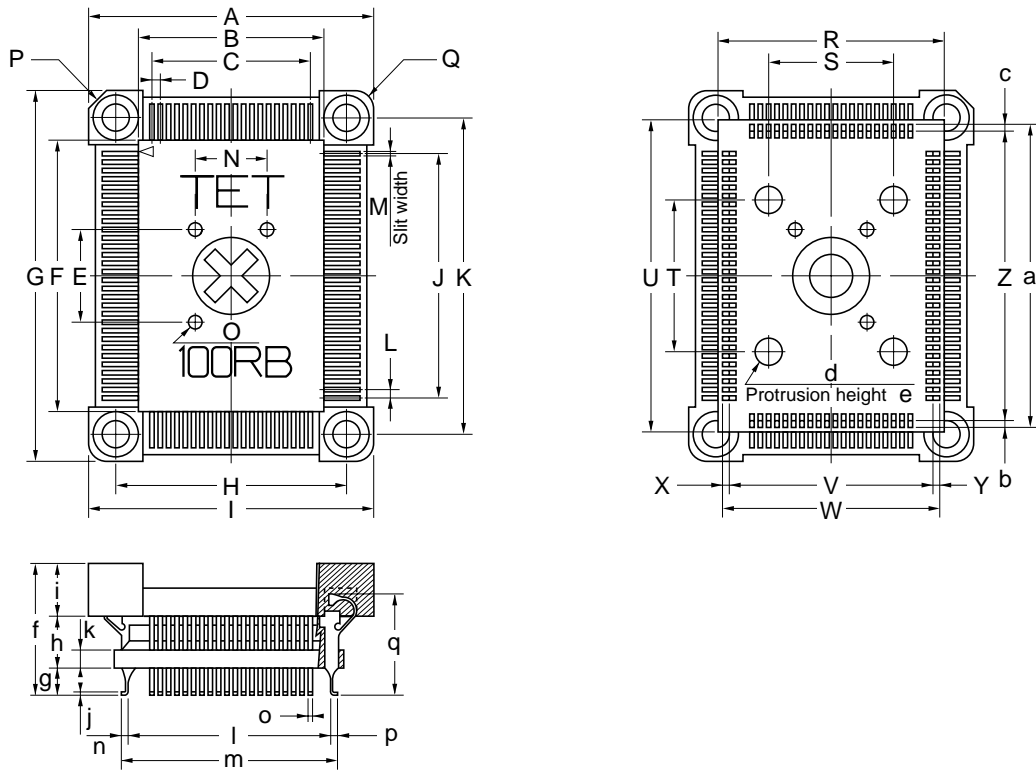

ITEM	MILLIMETERS	INCHES	ITEM	MILLIMETERS	INCHES
A	21.75	0.856	a	22.75	0.896
B	14.25	0.561	b	0.5	0.020
C	0.65x19=12.35	0.026x0.748=0.486	c	0.5	0.020
D	0.65	0.026	d	4-φ2.0	4-φ0.079
E	7.0	0.276	e	1.8	0.071
F	20.75	0.817	f	9.45	0.372
G	28.25	1.112	g	1.85	0.073
H	17.4	0.685	h	3.7	0.146
I	21.75	0.856	i	3.9	0.154
J	0.65x29=18.85	0.026x1.142=0.742	j	0.2	0.008
K	23.9	0.941	k	1.2	0.047
L	0.65	0.026	l	15.25	0.600
M	0.4	0.016	m	16.25	0.640
N	6.0	0.236	n	0.5	0.020
O	3-φ1.0	3-φ0.039	o	0.25	0.010
P	C 1.5	C 0.059	p	0.5	0.020
Q	3-R 1.5	3-R 0.059	q	6.95	0.274
R	17.15	0.675	NQPACK100RB-G1E		
S	10.0	0.394			
T	12.0	0.472			
U	23.65	0.931			
V	15.25	0.600			
W	16.25	0.640			
X	0.5	0.020			
Y	0.5	0.020			
Z	21.75	0.856			

note: Product by TOKYO ELETECH CORPORATION.

Figure A-4. External view of NQPACK100RB (Top Cover Mounted on Device) (Reference)

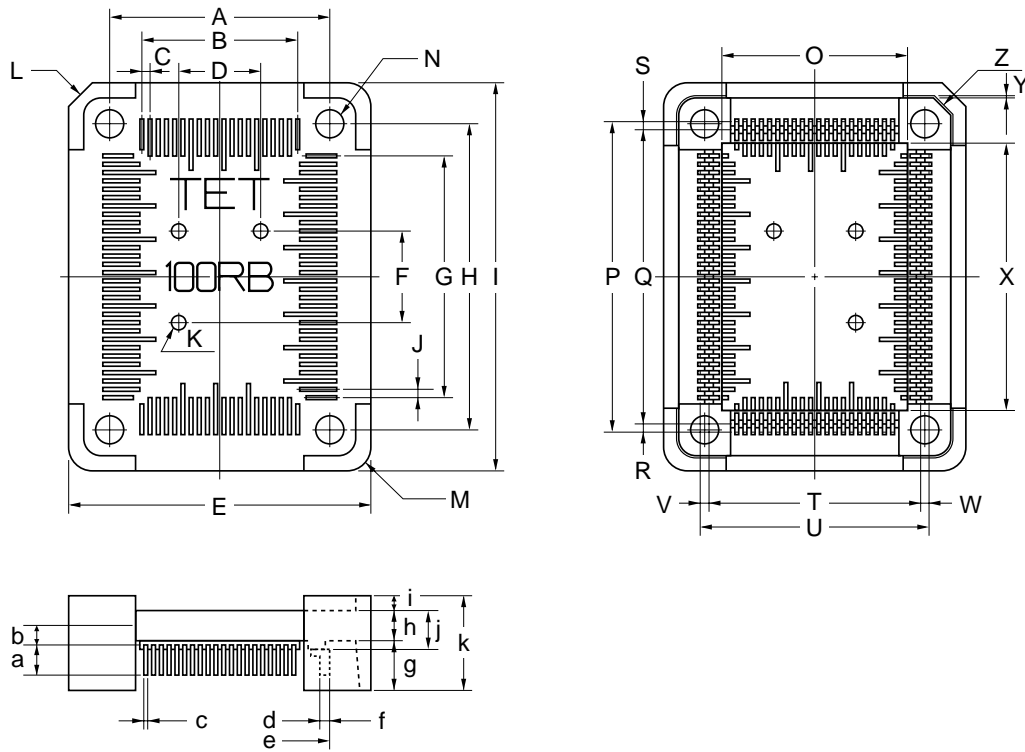

ITEM	MILLIMETERS	INCHES	ITEM	MILLIMETERS	INCHES
A	17.4	0.685	a	2.25	0.089
B	0.65x19=12.35	0.026x0.748=0.486	b	1.6	0.063
C	0.65	0.026	c	0.25	0.010
D	6.0	0.236	d	16.57	0.652
E	23.75	0.935	e	17.57	0.692
F	7.0	0.276	f	0.5	0.020
G	0.65x29=18.85	0.026x1.142=0.742	g	3.9	0.154
H	23.9	0.941	h	2.3	0.091
I	30.25	1.191	i	1.2	0.047
J	0.65	0.026	j	3.1	0.122
K	3- ϕ 1.0	3- ϕ 0.039	k	7.4	0.291
L	C 2.0	C 0.079	HQPACK100RB-G0E		
M	3-R 2.5	3-R 0.098			
N	4- ϕ 2.2	4- ϕ 0.087			
O	14.1	0.555			
P	24.07	0.948			
Q	23.07	0.908			
R	0.5	0.020			
S	0.5	0.020			
T	16.57	0.652			
U	17.57	0.692			
V	0.5	0.020			
W	0.5	0.020			
X	20.1	0.791			
Y	0.2	0.008			
Z	C 1.5	C 0.059			

note: Product by TOKYO ELETECH CORPORATION.

Figure A-5. External View of NQPACK100RB (Probe side) (Reference)

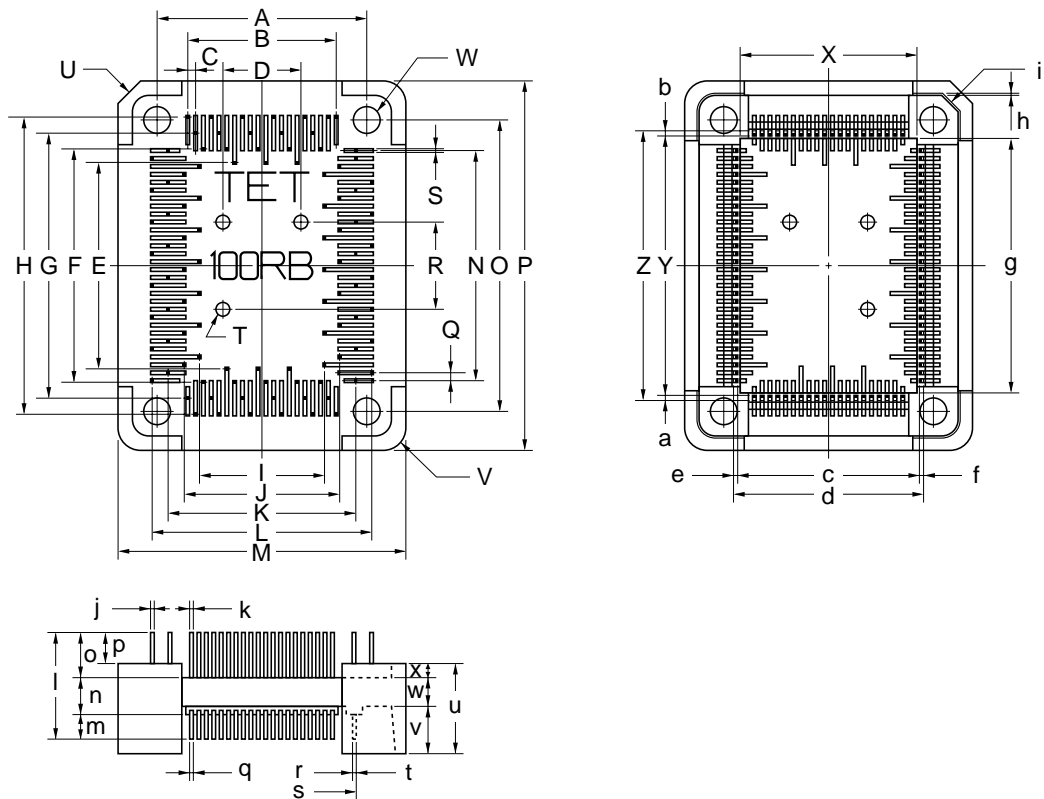

ITEM	MILLIMETERS	INCHES	ITEM	MILLIMETERS	INCHES
A	17.4	0.685	a	0.4	0.685
B	0.65x19=12.35	0.026x0.748=0.486	b	0.4	0.026
C	0.65	0.026	c	14.75	0.748
D	6.0	0.236	d	15.55	0.486
E	16.85	0.663	e	0.4	0.016
F	19.25	0.758	f	0.4	0.016
G	21.65	0.852	g	20.1	0.791
H	24.05	0.947	h	0.2	0.008
I	10.35	0.407	i	C 1.5	C 0.059
J	12.75	0.502	j	0.3	0.012
K	15.15	0.596	k	0.25x0.3	0.010x0.012
L	17.55	0.691	l	9.0	0.354
M	23.75	0.935	m	2.2	0.087
N	0.65x29=18.85	0.026x1.142=0.742	n	3.1	0.122
O	23.9	0.941	o	3.7	0.146
P	30.25	1.191	p	2.5	0.098
Q	0.65	0.026	q	0.25	0.010
R	7.0	0.276	r	14.75	0.581
S	0.25	0.010	s	15.55	0.612
T	3-φ1.0	3-φ0.039	t	0.4	0.016
U	C 2.0	C 0.079	u	7.4	0.291
V	3-R 2.5	3-R 0.098	v	3.9	0.154
W	4-φ2.2	4-φ0.087	w	2.3	0.091
X	14.1	0.555	x	1.2	0.047
Y	21.25	0.837			
Z	22.05	0.868			

YQPAC100RB-GOE

note: Product by TOKYO ELETECH CORPORATION.

[MEMO]

Facsimile Message

From:

Name

Company

Tel.

FAX

Address

Although NEC has taken all possible steps to ensure that the documentation supplied to our customers is complete, bug free and up-to-date, we readily accept that errors may occur. Despite all the care and precautions we've taken, you may encounter problems in the documentation. Please complete this form whenever you'd like to report errors or suggest improvements to us.

Thank you for your kind support.

North America

NEC Electronics Inc.
Corporate Communications Dept.
Fax: 1-800-729-9288
1-408-588-6130

Hong Kong, Philippines, Oceania

NEC Electronics Hong Kong Ltd.
Fax: +852-2886-9022/9044

Asian Nations except Philippines

NEC Electronics Singapore Pte. Ltd.
Fax: +65-250-3583

Europe

NEC Electronics (Europe) GmbH
Technical Documentation Dept.
Fax: +49-211-6503-274

Korea

NEC Electronics Hong Kong Ltd.
Seoul Branch
Fax: 02-528-4411

Japan

NEC Corporation
Semiconductor Solution Engineering Division
Technical Information Support Dept.
Fax: 044-548-7900

South America

NEC do Brasil S.A.
Fax: +55-11-889-1689

Taiwan

NEC Electronics Taiwan Ltd.
Fax: 02-719-5951

I would like to report the following error/make the following suggestion:

Document title: _____

Document number: _____ Page number: _____

If possible, please fax the referenced page or drawing.

Document Rating	Excellent	Good	Acceptable	Poor
Clarity	<input type="checkbox"/>	<input type="checkbox"/>	<input type="checkbox"/>	<input type="checkbox"/>
Technical Accuracy	<input type="checkbox"/>	<input type="checkbox"/>	<input type="checkbox"/>	<input type="checkbox"/>
Organization	<input type="checkbox"/>	<input type="checkbox"/>	<input type="checkbox"/>	<input type="checkbox"/>