

NEL Crystal Clock Oscillators

ECL COMPATIBLE

HS-600/2600 Series
(Available from 30MHz to 64.9 MHz)

HS-800/2800 Series
(Available from 65MHz to 250 MHz)

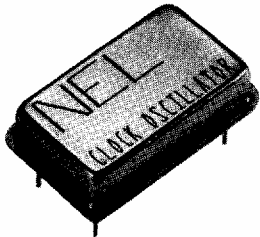

HS-600/2600 Series

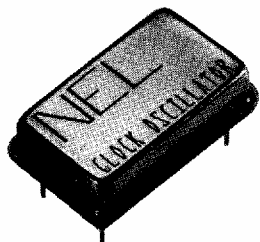

HS-800/2800 Series

Description

The **HS-600 & HS-800 Series** of quartz crystal clock oscillators provide MECL 10k, 10kH and 100k series compatible signals on pin 8.

The **HS-2600 & HS-2800 series** of quartz crystal clock oscillators provide complementary signals on pin 1. System designers may now specify space saving, cost effective ECL oscillators up to 250 MHz to meet their timing requirement. A wide frequency range is available, from 30 MHz to 250 MHz, with user specified tolerances from $\pm .005\%$, 0°C to $+70^{\circ}\text{C}$.

Features

- Wide frequency range — 30.0 MHz to 250.0 MHz
- User specified tolerance, from $\pm .005\%$
- Case at electrical ground
- MECL 10 k, 10 kH and 100 k Series compatible output on Pin 8, complement on Pin 1, or both
- Space-saving alternative to discrete component oscillators
- All metal, resistance weld, hermetically sealed package
- High shock resistance, to 3,000 Gs

NEL TYPE, FREQUENCY RANGE, PIN CONNECTIONS

NEL OSC. TYPE	FREQUENCY RANGE	PIN CONNECTION				SIGNAL COMPATIBILITY
		1	7	8	14	
HS-600	30 MHz to 64.9 MHz	N/C	CASE & GRD (V_{CC})	OUTPUT	$V_{EE}(-5.2V)$	10k & 10kH
HS-610	30MHz to 64.9 MHz	N/C	$V_{EE}(-5.2V)$	OUTPUT	CASE & GRD (V_{CC})	10k & 10kH
HS-620	30MHz to 64.9 MHz	N/C	CASE & GRD (V_{CC})	OUTPUT	$V_{EE}(-4.5V)$	100k
HS-630	30MHz to 64.9 MHz	N/C	$V_{EE}(-4.5V)$	OUTPUT	CASE & GRD (V_{CC})	100k
HS-670	30MHz to 64.9 MHz	N/C	CASE & GRD	OUTPUT	$V_{CC} (+5V)$	10k & 10kH
HS-800	65MHz to 250 MHz	N/C	CASE & GRD (V_{CC})	OUTPUT	$V_{EE}(-5.2V)$	10k & 10kH
HS-810	65MHz to 250 MHz	N/C	$V_{EE}(-5.2V)$	OUTPUT	CASE & GRD (V_{CC})	10k & 10kH
HS-820	65MHz to 250 MHz	N/C	CASE & GRD (V_{CC})	OUTPUT	$V_{EE}(-4.5V)$	100K
HS-830	65MHz to 250 MHz	N/C	$V_{EE}(-4.5V)$	OUTPUT	CASE & GRD (V_{CC})	100K
HS-870	65MHz to 250 MHz	N/C	CASE & GRD	OUTPUT	$V_{CC} (+5.0V)$	10k & 10kH
HS-2600	30MHz to 64.9 MHz	Comp. Out	CASE & GRD (V_{CC})	OUTPUT	$V_{EE}(-5.2V)$	10k & 10kH
HS-2610	30MHz to 64.9 MHz	Comp. Out	$V_{EE}(-5.2V)$	OUTPUT	CASE & GRD (V_{CC})	10k & 10kH
HS-2670	30MHz to 64.9 MHz	Comp. Out	CASE & GRD	OUTPUT	$V_{CC} (+5.0V)$	10k & 10kH
HS-2800	65MHz to 250 MHz	Comp. Out	CASE & GRD (V_{CC})	OUTPUT	$V_{EE}(-5.2V)$	10k & 10kH
HS-2810	65MHz to 250 MHz	Comp. Out	$V_{EE}(-5.2V)$	OUTPUT	CASE & GRD (V_{CC})	10k & 10kH
HS-2870	65MHz to 250 MHz	Comp. Out	CASE & GRD	OUTPUT	$V_{CC} (+5.0V)$	10k & 10kH

Dimensions

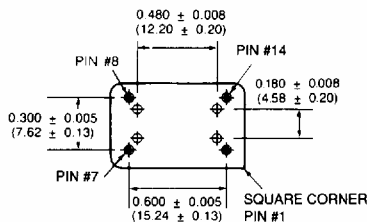
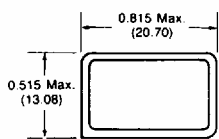

Pin Connection
See Chart to Right

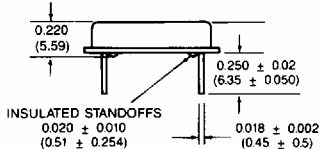

Dimensions are for reference only, inches (mm).

ECL Operating Conditions and Output Characteristics

**ECL
COMPATIBLE**

**HS-600/2600
Series
(Available from
30MHz to
64.9 MHz)**

**HS-800/2800
Series
(Available from
65MHz to
250 MHz)**

PARAMETER	CONDITIONS	HS-600/610 Series HS-800/810 Series HS-2600/2610 Series HS-2800/2810 Series		HS-620/630 Series HS-820/830 Series		HS-670 Series HS-870 Series HS-2670 Series HS-2870 Series		
		MINIMUM	MAXIMUM	MINIMUM	MAXIMUM	MINIMUM	MAXIMUM	
		(Note 1)		(Note 2)		(Note 3)		
General Characteristics								
Supply voltage (V_{EE})	-5.2V	-5.46V	-4.94 V	—	—	—	—	
	-4.5V	—	—	-4.8V	-4.2V	—	—	
	+5.0V	—	—	—	—	+4.75V	+5.25V	
	Breakdown	+0.5V	-8.0V	+0.5V	-8.0V	-0.5V	+8.0V	
Supply current (I_{EE})	—	—	80 mA	—	80 mA	—	80 mA	
Output current (I_O)	HS-6XX/26XX Series	—	50 mA	—	50 mA	—	50 mA	
	HS-8XX/28XX Series	—	50 mA	—	50 mA	—	50 mA	
Operating temperature (T_A)	Functionality only	0° C	70° C	0° C	70° C	0° C	70° C	
Storage temperature (T_S)	—	-55° C	+125° C	-55° C	+125° C	-55° C	+125° C	
Output Characteristics (1)								
Frequency	HS-6XX/26XX Series	30 MHz	64.9 MHz	30 MHz	64.9 MHz	30 MHz	64.9 MHz	
	HS-8XX/28XX Series	65 MHz	250 MHz	65 MHz	250 MHz	65 MHz	250 MHz	
Tolerance ⁽²⁾	@ 25° C	±0.05%	—	±0.05%	—	±0.05%	—	
Stability	0-70° C	±0.1%	—	±0.1%	—	±0.1%	—	
Symmetry ⁽³⁾	@-1.29 V	40/60%	60/40%	—	—	—	—	
	@-1.33 V	—	—	40/60%	60/40%	—	—	
	@+3.71V	—	—	—	—	40/60%	60/40%	
Logic 0 (V_{OL}) ⁽⁴⁾	HS-6XX/26XX Series	-1.87 V	-1.625 V	-1.81 V	-1.475 V	3.13 V	3.375V	
	HS-8XX/28XX Series	-1.95 V	-1.60 V	-1.81 V	-1.475 V	3.05 V	3.40 V	
Logic 1 (V_{OH}) ⁽⁴⁾	HS-6XX/26XX Series	-1.06 V	-0.74 V	-1.165 V	-0.88 V	3.94 V	4.28 V	
	HS-8XX/28XX Series	-1.02 V	-0.74 V	-1.165 V	-0.88 V	3.98 V	4.26 V	
Rise & fall time (t_r, t_f) ⁽⁵⁾	HS-6XX/26XX Series	—	3.6 ns	—	3.6 ns	—	3.6 ns	
	HS-8XX/28XX Series	—	2.25 ns	—	2.25 ns	—	2.25 ns	

Note 1 – Limits are for -5.2 V ±0.01 V @ 25° C unless otherwise specified.

Note 2 – Limits are for -4.5 V ±0.01 V @ 25° C unless otherwise specified.

Note 3 – Limits are for +5.0 V ±0.01 V @ 25° C unless otherwise specified.

Footnotes:

1. Tested per test circuit diagram
2. Unless otherwise specified by customer
3. Reference test circuit below
4. V_{OL} , V_{OH} referenced to ground
5. Measured between 20% and 80% of output

Test Circuit

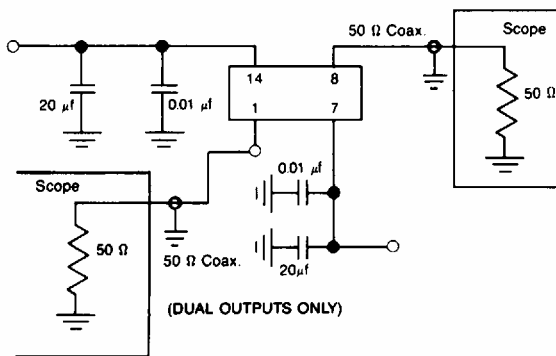

This information is believed to be reliable at the time of printing; no responsibility is assumed for inaccuracies. NEL Frequency Controls reserves the right to make changes at any time.

Output Waveform

