

PLEASE CHECK WWW.MOLEX.COM FOR LATEST PART INFORMATION

Part Number: [0039000021](#)
Status: **Active**
Overview: [spox_bmi](#)
Description: SPOX™ Crimp Terminal 5194, 18-24 AWG, Phosphor Bronze, Reel

Documents:

Drawing (PDF)	Product Specification PS-5195-006 (PDF)
Product Specification PS-5195-004 (PDF)	Product Specification PS-5195-007 (PDF)
Product Specification PS-5195-005 (PDF)	RoHS Certificate of Compliance (PDF)

General

Product Family	Crimp Terminals
Series	5194
Crimp Quality Equipment	Yes
Overview	spox_bmi
Product Name	SPOX™

Physical

Gender	Female
Material - Metal	Phosphor Bronze
Material - Plating Mating	Tin
Material - Plating Termination	Tin
Packaging Type	Reel
Plating min: Mating (µin)	36
Plating min: Mating (µm)	0.90
Plating min: Termination (µin)	36
Plating min: Termination (µm)	0.90
Termination Interface: Style	Crimp or Compression
Wire Insulation Diameter	1.30-3.20mm (.051-.126")
Wire Size AWG	18, 20, 22, 24
Wire Size mm²	N/A

Material Info

Old Part Number	5194PBT
-----------------	---------

Reference - Drawing Numbers

Packaging Specification	SPK-5194-001
Product Specification	PS-5195-004, PS-5195-005, PS-5195-006, PS-5195-007, RPS-5195-001, RPS-5195-002
Sales Drawing	SD-5194-001

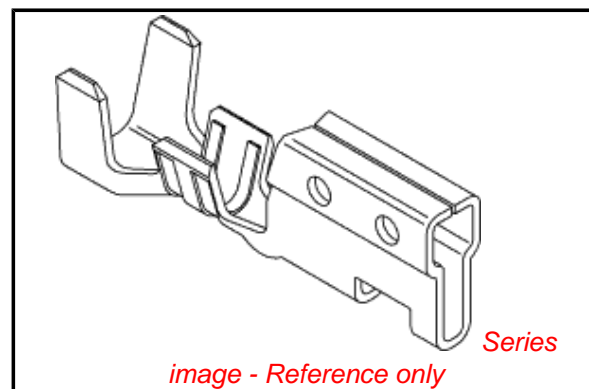

EU RoHS

**ELV and RoHS
Compliant**
**REACH SVHC
Contains SVHC: No**
**Halogen-Free
Status**

China RoHS



**Need more information on product
environmental compliance?**

Email productcompliance@molex.com
 For a multiple part number RoHS Certificate of
 Compliance, [click here](#)

Please visit the [Contact Us](#) section for any
 non-product compliance questions.

Search Parts in this Series

5194Series

Use With

5195 , 5196 , 5197 , 5198 , 5199

Application Tooling | FAQ

*Tooling specifications and manuals are
 found by selecting the products below.
 Crimp Height Specifications are then
 contained in the Application Tooling
 Specification document.*

Global

Description	Product #
FineAdjust™ Applicator for 3.96mm (.156") Pitch SPOX™ Crimp Terminal, 18-24 AWG	0639005300
T2 Terminator Tooling Die for SPOX™ Crimp	0639105300

Terminal, 18-24
AWG
Hand Crimp Tool 0638116500

Japan

Description	Product #
--------------------	------------------

Applicator for M211A	<u>0011260028</u>
----------------------	-------------------

Bench Press, 18-28

AWG, for 5225 and

5194 Crimp Terminal

Hand Extraction Tool	<u>0011260100</u>
----------------------	-------------------

This document was generated on 05/19/2010

PLEASE CHECK WWW.MOLEX.COM FOR LATEST PART INFORMATION

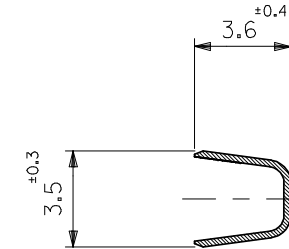
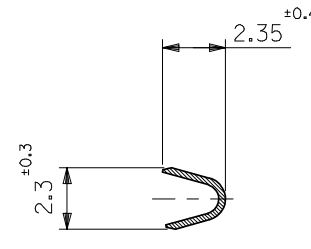
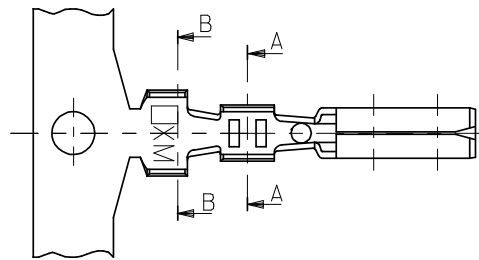

断面 A-A
SECT. A-A

断面 B-B
SECT. B-B

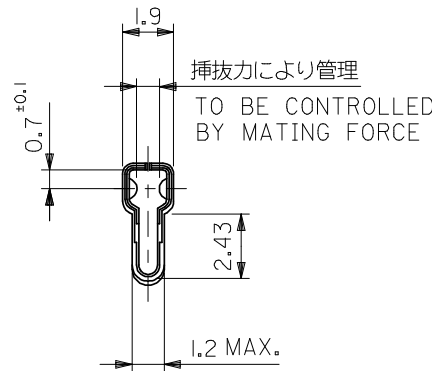
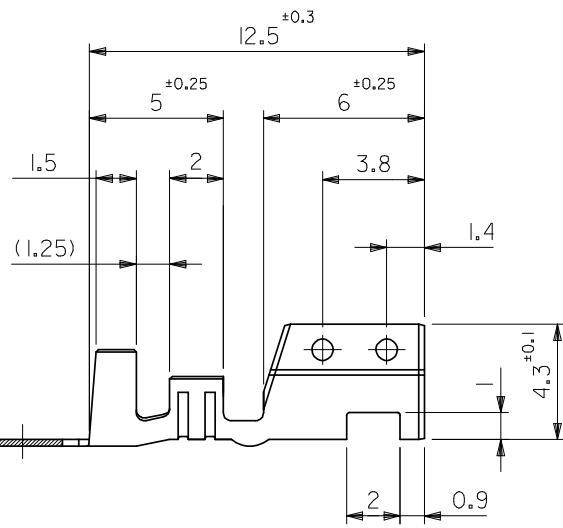

注記
NOTES

1. 適合ハウジング : 5195-N* , 5196-N*
 APPLICABLE HOUSING 5197-N* , 5198-N*
 5199-N*

材料	表面処理	EDP NO.	ENG. NO.	端子形状
錫メッキ済リン青銅 PRE-TINNED PHOSPHOR BRONZE	Sn : 0.9 μ MIN	39-00-0022	5194PBT	バラ状 LOOSE
		39-00-0021	5194PBT	連鎖状 CHAIN
錫メッキ済黄銅 PRE-TINNED BRASS	Sn : 0.9 μ MIN, Cu : 0.5 μ MIN	08-70-1030	5194TL	バラ状 LOOSE
		08-70-1031	5194T	連鎖状 CHAIN

材料 MATERIAL	表参照 SEE TABLE 板厚: 0.254 (t=0.254)
仕上げ FINISH	表参照 SEE TABLE
適用電線範囲 WIRE RANGE	AWG #18-#24
被覆外径 INS. RANGE	ϕ 1.3 - ϕ 3.2

REVISED EC NO: J2008-3351 DRWN:WABEI 2008/03/24 CHKD:THARUYAMA 2008/03/24 APPR:NUKITA 2008/03/24 REV J	GENERAL TOLERANCES (UNLESS SPECIFIED)	10 UNDER ± 0.2	10 OVER 30 UNDER ± 0.25	30 OVER ± 0.3	ANGULAR $\pm 3^\circ$	DRAFT WHERE APPLICABLE MUST REMAIN WITHIN DIMENSIONS
	DIMENSION STYLE MM ONLY					
	DRAWN BY K. HASHIMOTO		DATE '96/05/21		TITLE SPOX CRIMP RECEPTACLE	
	CHECKED BY S. KUNISHI		DATE '98/07/07		APPROVED BY M. FUKUSHIMA	
	APPROVED BY M. FUKUSHIMA		DATE '98/07/07		MATERIAL NO. DOCUMENT NO.	

SCALE 5:1	DESIGN UNITS METRIC	THIRD ANGLE PROJECTION
MATERIAL FINISH		
SEE TABLE		
MOLEX INCORPORATED		SHEET NO. 1 OF 1
THIS DRAWING CONTAINS INFORMATION THAT IS PROPRIETARY TO MOLEX INCORPORATED AND SHOULD NOT BE USED WITHOUT WRITTEN PERMISSION		