



Helping Customers Innovate, Improve & Grow



### Description

Vectron's VC-709 Crystal Oscillator is a quartz stabilized, differential output oscillator, operating off a 2.5 or 3.3 volt supply in a hermetically sealed 5x7 ceramic package.

### Features

- Ultra Low Jitter Performance, 3rd OT or Fundamental Crystal Design
- 13.500-170.0000MHz Output Frequencies
- Low Power
- 400ps max Rise and Fall Time
- Excellent Power Supply Rejection Ratio
- Enable/Disable
- 3.3 or 2.5V operation
- -10/70°C or -40/85°C Operation
- Hermetically Sealed 5x7 Ceramic Package
- Product is compliant to RoHS directive  and fully compatible with lead free assembly

### Applications

- PCI Express
- Ethernet, GbE, Synchronous Ethernet
- Fiber Channel
- Enterprise Servers
- Telecom
- Clock source for A/D's, D/A's
- Driving FPGA's
- Test and Measurement
- PON
- Medical
- COTS

### Block Diagram

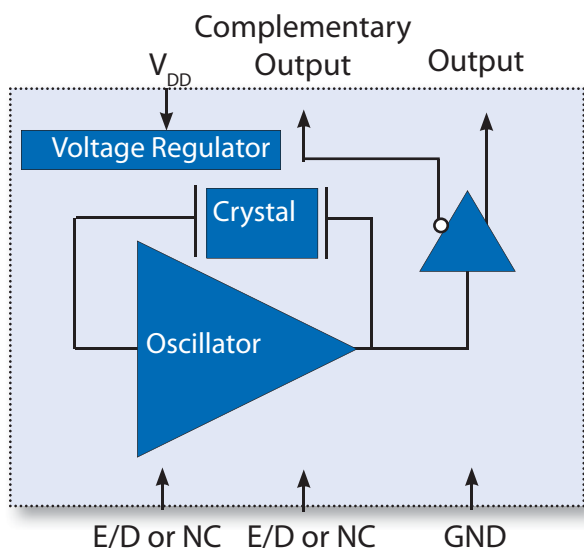

### Phase Noise

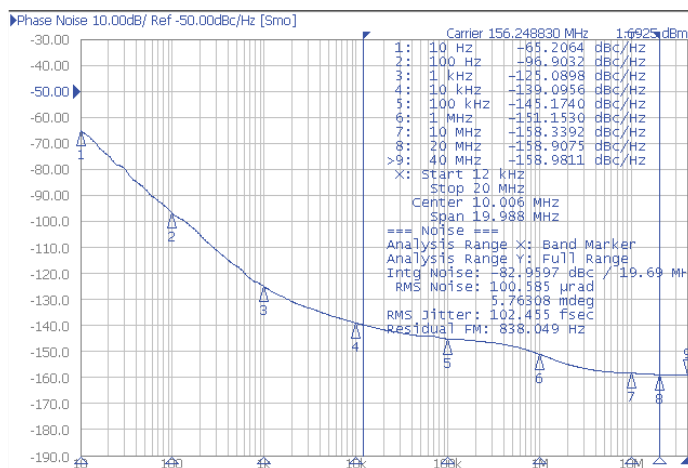

# Performance Specifications

**Table 1. Electrical Performance, LVPECL Option**

Parameter	Symbol	Min	Typical	Maximum	Units
<b>Supply</b>					
Voltage <sup>1</sup>	$V_{DD}$	3.135	3.3	3.465	V
		2.375	2.5	2.625	V
Current (No Load)	$I_{DD}$		35	50	mA
<b>Frequency</b>					
Nominal Frequency	$f_N$	13.5		170.000	MHz
Stability <sup>3</sup> (Ordering Option)		$\pm 25, \pm 50$ or $\pm 100$			ppm
<b>Outputs</b>					
Output Logic Levels <sup>4</sup>	$V_{OH}$ $V_{OL}$	$V_{DD}-1.085$		$V_{DD}-0.880$	V
		$V_{DD}-1.830$		$V_{DD}-1.555$	V
Output Rise and Fall Time <sup>3</sup>	$t_R/t_F$			500	ps
Load		50 ohms into $V_{DD}-1.3V$			
Duty Cycle <sup>4</sup>		45		55	%
Jitter, 156.250MHz <sup>5</sup>	$\phi J$	12kHz-50MHz		200	fs
		12kHz-20MHz		150	fs
		10kHz-1MHz		100	fs
Period Jitter <sup>6</sup>	$\phi J$	RMS	1.1		ps
		P/P	10.5		ps
Cycle-Cycle <sup>6</sup>		RMS	1.9		ps
		P/P	17.7		ps
Random Jitter <sup>7</sup>			2.2		ps
Deterministic Jitter <sup>7</sup>			0		ps
<b>Enable/Disable</b>					
Output Enabled <sup>8</sup>	$V_{IH}$	$0.7*V_{DD}$			V
Output Disabled	$V_{IL}$			$0.3*V_{DD}$	V
Disable Time	$t_D$			200	ns
Enable/Disable Leakage Current				$\pm 200$	uA
Start-Up Time	$t_{SU}$			2	ms
Operating Temp. (Ordering Option)	$T_{OP}$	$-10/70$ or $-40/85$			°C
Package Size		$5.0 \times 7.0 \times 1.6$			mm

1. The VC-709 power supply pin should be filtered, eg, a 0.1 and 0.01uf capacitor.
2. Includes calibration tolerance, operating temperature, supply voltage variations, aging and IR reflow.
3. Figure 3 defines the test circuit and Figure 4 defines these parameters.
4. Duty Cycle is defined as the On/Time Period.
5. Measured using an Agilent E5052.
6. Measured using a LeCroy Wavemaster 8600A, 90K samples
7. Measured using a Wavecrest SIA3300C, 90K samples.
8. Outputs will be Enabled if Enable/Disable is left open.

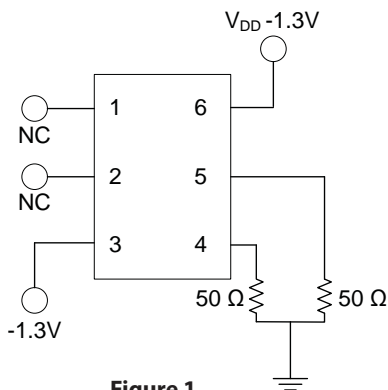

**Figure 1.**

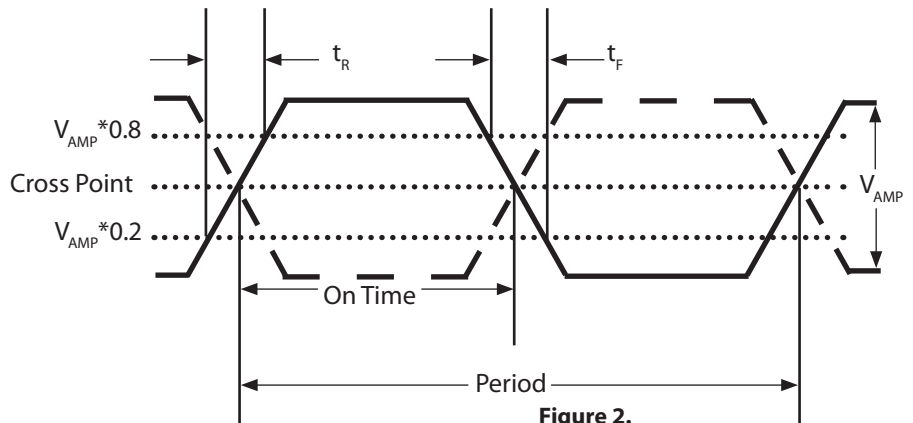

**Figure 2.**

# Performance Specifications

**Table 2. Electrical Performance, LVDS Option**

Parameter	Symbol	Min	Typical	Maximum	Units
<b>Supply</b>					
Voltage <sup>1</sup>	$V_{DD}$	3.135 2.375	3.3 2.5	3.465 2.625	V V
Current (No Load)	$I_{DD}$			60	mA
<b>Frequency</b>					
Nominal Frequency	$f_N$	13.5		170.000	MHz
Stability <sup>2</sup> (Ordering Option)		±25, ±50 or ±100			ppm
<b>Outputs</b>					
Output Logic Levels <sup>3</sup> Output Logic High Output Logic Low	$V_{OH}$ $V_{OL}$	0.9	1.43 1.10	1.6	V V
Differential Output Amplitude		250	350	450	mV
Differential Output Error				50	mV
Offset Voltage		1.125	1.25	1.375	V
Offset Voltage Error				50	mV
Output Leakage Current				10	uA
Output Rise and Fall Time <sup>3</sup>	$t_R/t_F$			400	ps
Load		100 ohms differential			
Duty Cycle <sup>4</sup>		45		55	%
Jitter, 156.250MHz <sup>5</sup> 12kHz - 50MHz 12kHz - 20MHz 10kHz - 1MHz	$\phi J$			200 150 100	fs fs fs
Period Jitter <sup>6</sup> RMS P/P Cycle-Cycle Jitter <sup>6</sup> RMS P/P Random Jitter <sup>7</sup> Deterministic Jitter <sup>7</sup>	$\phi J$		1.1 10.5 1.9 17.7 2.2 0		ps ps ps ps ps ps
<b>Enable/Disable</b>					
Output Enabled <sup>8</sup> Output Disabled	$V_{IH}$ $V_{IL}$	0.7* $V_{DD}$		0.3* $V_{DD}$	V V
Disable Time	$t_D$			200	ns
Enable/Disable Leakage Current	$I_{E/D}$			±200	uA
Start-Up Time	$t_{SU}$			2	ms
Operating Temp. (Ordering Option)	$T_{OP}$	-10/70 or -40/85			°C
Package Size		5.0 x 7.0 x 1.6			mm

1. The VC-709 power supply pin should be filtered, eg, a 0.1 and 0.01 uF capacitor.
2. Includes calibration tolerance, operating temperature, supply voltage variations, aging and IR reflow.
3. Figure 5 defines these parameters and Figure 4 defines the test circuit.
4. Duty Cycle is defined as the On/Time Period.
5. Measured using an Agilent E5052.
6. Measured using a LeCroy Wavemaster 8600A, 90K samples.
7. Measured using a Wavecrest SIA3300C, 90K samples.
8. Outputs will be Enabled if Enable/Disable is left open.

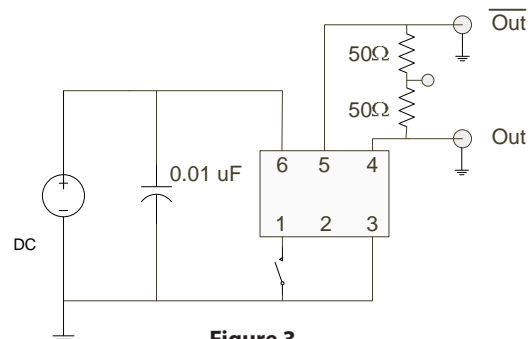

**Figure 3.**

# Performance Specifications

**Table 3. Electrical Performance, HCSL Output**

Parameter	Symbol	Min	Typical	Maximum	Units
<b>Supply</b>					
Voltage <sup>1</sup>	$V_{DD}$	2.375 3.165	2.5 3.3	2.625 3.465	V
Current (No Load)	$I_{DD}$			30	mA
<b>Frequency</b>					
Nominal Frequency	$f_N$	13.5		170	MHz
Stability <sup>2</sup> (Ordering Options)		$\pm 25, \pm 50$ or $\pm 100$			ppm
<b>Outputs</b>					
Output Logic Swing	$V_{OH}$	0.62		0.78	V
Output Rise and Fall Time <sup>3</sup>	$t_R/t_F$			400	ps
Load		50 ohms to ground			
Duty Cycle <sup>4</sup>		45		55	%
Jitter (12 kHz - 20 MHz) 100.000MHz <sup>5</sup>	$\phi J$			300	fs
Period Jitter <sup>6</sup>	$\phi J$				
RMS			1.0		ps
P/P			9.7		ps
Cycle-Cycle Jitter <sup>6</sup>					
RMS			1.8		ps
P/P			18.3		ps
Random Jitter <sup>7</sup>			2.2		ps
Deterministic Jitter <sup>7</sup>			0		ps
<b>Enable/Disable</b>					
Output Enabled <sup>8</sup>	$V_{IH}$	0.7* $V_{DD}$			V
Output Disabled	$V_{IL}$			0.3* $V_{DD}$	V
Disable Time	$t_D$			200	ns
Enable/Disable Leakage Current	$I_{E/D}$			$\pm 200$	$\mu A$
Start-Up Time	$t_{SU}$			2	ms
Operating Temp. (Ordering Option)	$T_{OP}$	-10/70 or -40/85			$^{\circ}C$
Package Size		5.0 x 7.0 x 1.6			mm

1. The VC-709 power supply pin should be filtered, e.g., a 0.1 and 0.01uf capacitor.
2. Includes calibration tolerance, operating temperature, supply voltage variations, aging and IR reflow.
3. Figure 1 defines the test circuit and Figure 2 defines these parameters.
4. Duty Cycle is defined as the On Time/Period.
5. Measured using an Agilent E5052.
6. Measured using a LeCroy Wavemaster 8600A, 90K samples.
7. Measured using a Wavecrest SIA3300C, 90K samples.
8. Outputs will be Enabled if the Enable/Disable pad is left open.

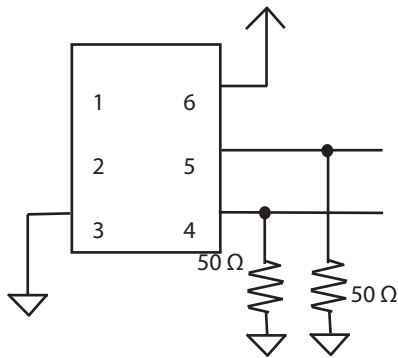

**Figure 4.**

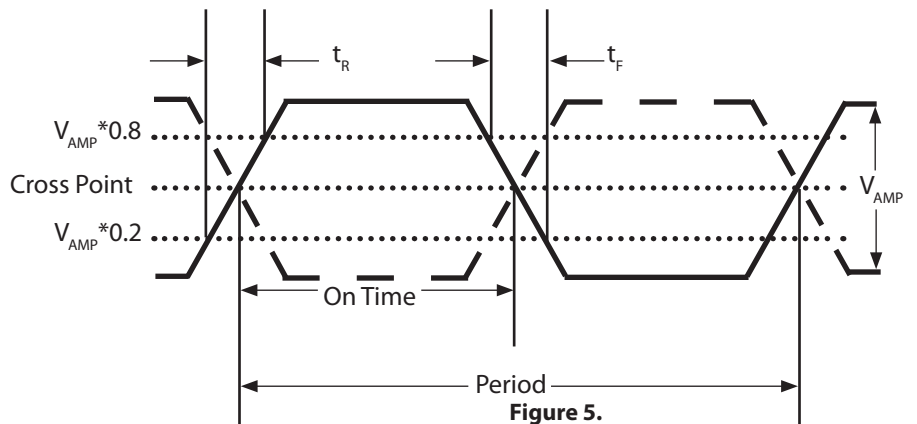
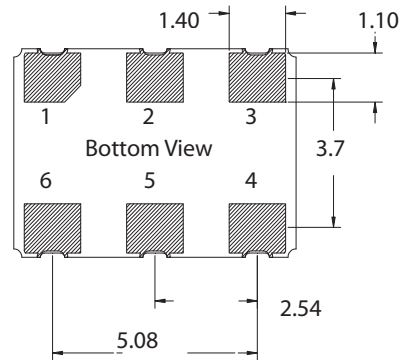
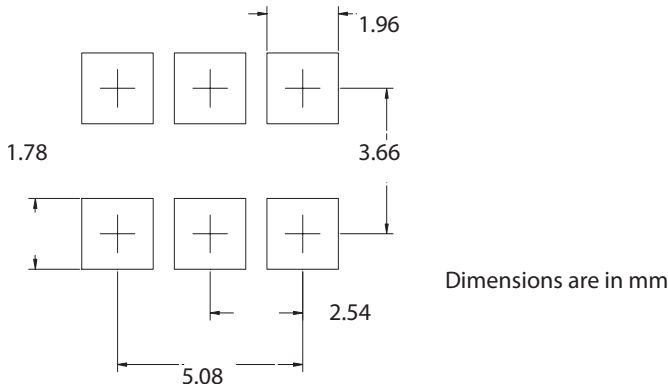
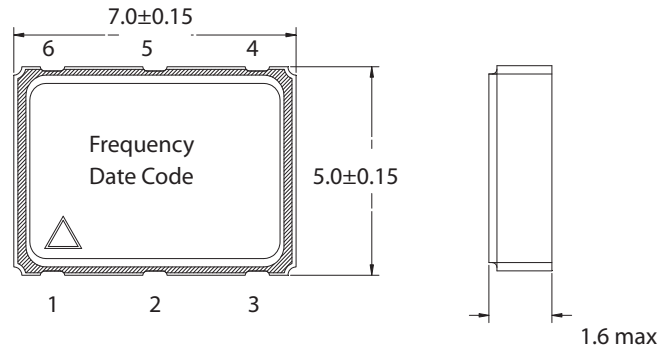

**Figure 5.**

# Package and Pinout

**Table 4. Pinout**

Pin #	Symbol	Function
1	E/D or NC	Enable/Disable
2	E/D or NC	Enable/Disable
3	GND	Electrical and Lid Ground
4	$f_o$	Output Frequency
5	$Cf_o$	Complementary Output Frequency
6	$V_{DD}$	Supply Voltage



**Figure 6. Pad Layout**

**Figure 7. Package Outline Drawing**

# HCSL Application Diagrams

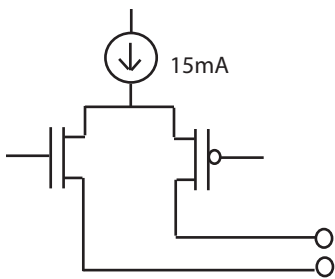

**Figure 8. Standard HCSL Output Configuration**

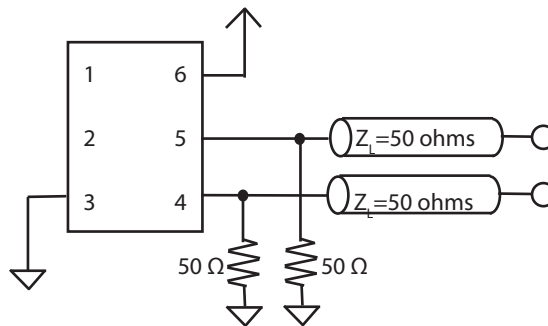

**Figure 9. Single Resistor Termination Scheme**

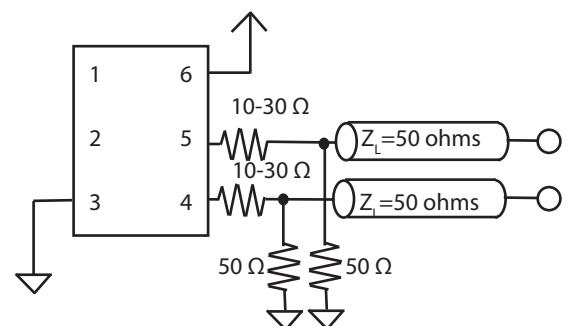
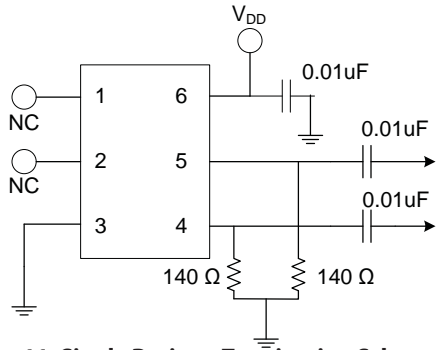

**Figure 10. In some cases a 10-30 ohm series resistor is used to help reduce overshoot.**

The VC-709 incorporates a standard High Speed Current Logic, HCSL, output scheme which is a 15mA current source switched between Out and Complementary Out. Being un-terminated drains, as shown in Figure 8, they require external 50 ohm resistors to ground as shown in Figure 9. HCSL is a high impedance output with quick switching times, in can be advantageous to use a 10 to 30 ohm series resistor as shown in Figure 10, to help reduce overshoot/ringing.

One of the most important considerations is terminating the Output and Complementary Outputs equally. An unused output should not be left un-terminated, and if it one of the two outputs is left open it will result in excessive jitter on both. PC board layout must take this and 50 ohm impedance matching into account. Load matching and power supply noise are the main contributors to jitter related problems.

## LVPECL Application Diagrams



**Figure 11. Single Resistor Termination Scheme**  
Resistor values are typically 140 ohms for 3.3V operation and 84 ohms for 2.5V operation.

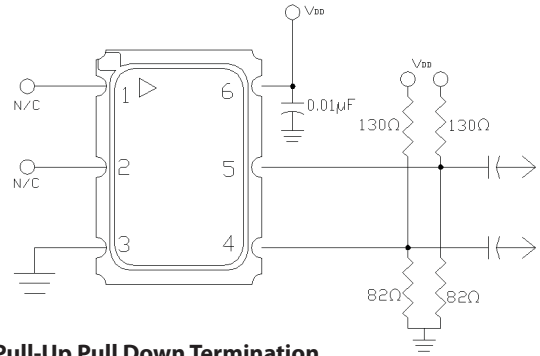
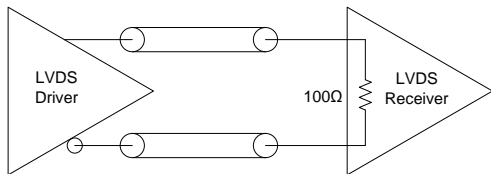

**Figure 12. Pull-Up Pull Down Termination**  
Resistor values shown are typical for 3.3 V operation. For 2.5V operation, the resistor to ground is 62 ohms and the resistor to supply is 250 ohms

The VC-709 incorporates a standard PECL output scheme, which are un-terminated FET drains. There are numerous application notes on terminating and interfacing PECL logic and the two most common methods are a single resistor to ground, Figure 11, or for best 50 ohm matching a pull-up/pull-down scheme as shown in Figure 12 should be used. AC coupling capacitors are optional, depending on the application and the input logic requirements of the next stage.

One of the most important considerations is terminating the Output and Complementary Outputs equally. An unused output should not be left un-terminated, and if one of the two outputs is left open it will result in excessive jitter on both. PC board layout must take this and 50 ohm impedance matching into account. Load matching and power supply noise are the main contributors to jitter related problems.

## LVDS Application Diagrams



**Figure 13. LVDS to LVDS Connection, Internal 100ohm Resistor**  
Some LVDS structures have an internal 100 ohm resistor on the input and do not need additional components. AC blocking capacitors can be used if the DC levels are incompatible.

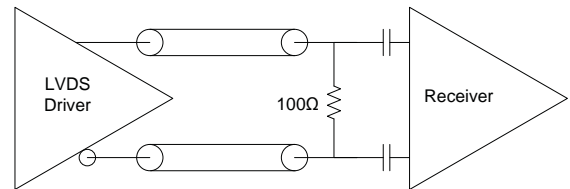

**Figure 14. LVDS to LVDS Connection**  
Some input structures may not have an internal 100 ohm resistor on the input and will need an external 100ohm resistor for impedance matching. Also, the input may have an internal DC bias which may not be compatible with LVDS levels, AC blocking capacitors can be used.

One of the most important considerations is terminating the Output and Complementary Outputs equally. An unused output should not be left un-terminated, and if one of the two outputs is left open it will result in excessive jitter on both. PC board layout must take this and 50 ohm impedance matching into account. Load matching and power supply noise are the main contributors to jitter related problems.

## Environmental and IR Compliance

Table 5. Environmental Compliance	
Parameter	Condition
Mechanical Shock	MIL-STD-883 Method 2002
Mechanical Vibration	MIL-STD-883 Method 2007
Temperature Cycle	MIL-STD-883 Method 1010
Solderability	MIL-STD-883 Method 2003
Fine and Gross Leak	MIL-STD-883 Method 1014
Resistance to Solvents	MIL-STD-202 Method 215
Moisture Sensitivity Level	MSL1
Contact Pads	Gold over Nickel

# IR Compliance

## Suggested IR Profile

Devices are built using lead free epoxy and can be subjected to standard lead free IR reflow conditions shown in Table 6. Contact pads are gold over nickel and lower maximum temperatures can also be used, such as 220C.

Parameter	Symbol	Value
PreHeat Time	$t_s$	200 sec Max
Ramp Up	$R_{UP}$	3°C/sec Max
Time above 217°C	$t_L$	150 sec Max
Time to Peak Temperature	$t_{AMB-P}$	480 sec Max
Time at 260°C	$t_P$	30 sec Max
Time at 240°C	$t_{P2}$	60 sec Max
Ramp down	$R_{DN}$	6°C/sec Max

Solderprofile:

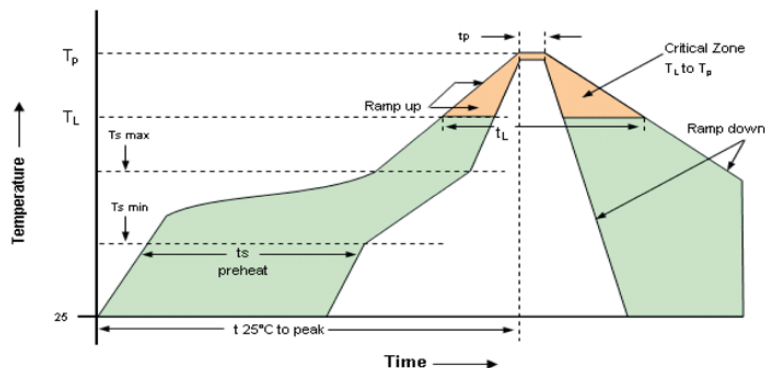

## Maximum Ratings, Tape & Reel

### Absolute Maximum Ratings and Handling Precautions

Stresses in excess of the absolute maximum ratings can permanently damage the device. Functional operation is not implied or any other excess of conditions represented in the operational sections of this data sheet. Exposure to absolute maximum ratings for extended periods may adversely affect device reliability.

Although ESD protection circuitry has been designed into the VC-709, proper precautions should be taken when handling and mounting, VI employs a Human Body Model and Charged Device Model for ESD susceptibility testing and design evaluation.

ESD thresholds are dependent on the circuit parameters used to define the model. Although no industry standard has been adopted for the CDM a standard resistance of 1.5kOhms and capacitance of 100pF is widely used and therefor can be used for comparison purposes.

Parameter		Unit
Storage Temperature	-55 to 125	°C
Junction Temperature	150	C
Supply Voltage	-0.5 to 5.0	V
Enable Disable Voltage	-0.5 to $V_{DD}+0.5$	V
ESD, Human Body Model	1500	V
ESD, Charged Device Model	1500	V

Table 8. Tape and Reel Information

Tape Dimensions (mm)					Reel Dimensions (mm)							
W	F	Do	Po	P1	A	B	C	D	N	W1	W2	#/Reel
16	7.5	1.5	4	8	180	2	13	21	50	17	21	250

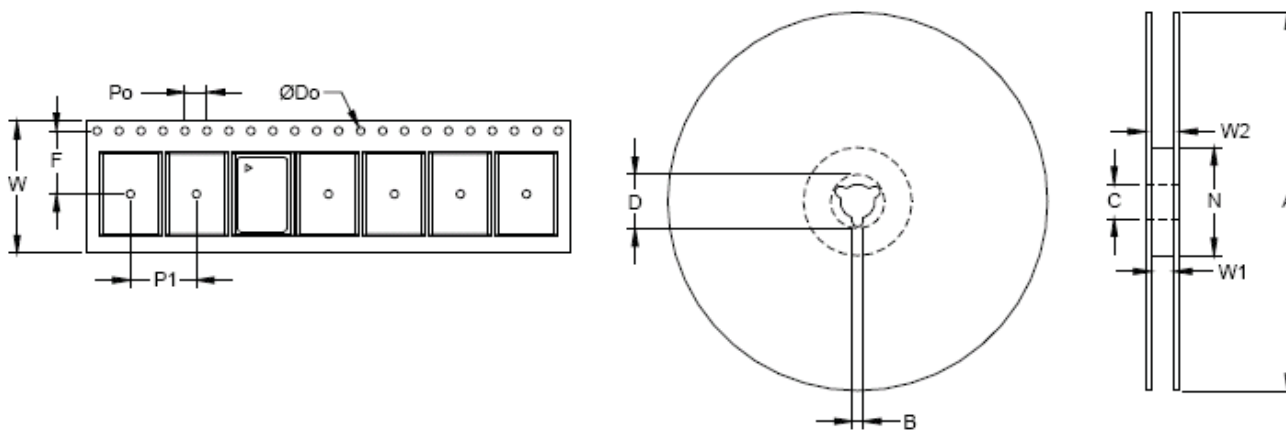



## Ordering Information

### VC-709- E C E - K A A N - xxxMxxxxxx

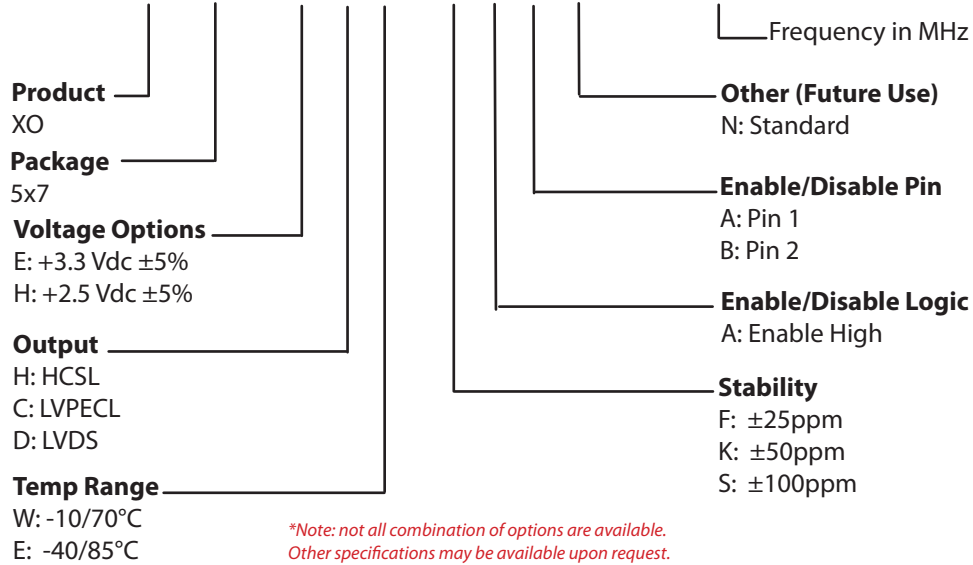

**Example: VC-709-ECE-KAAN-156M250**

### ±20ppm Options

- VC-709-107-frequency= LVPECL, +3.3V, ±20ppm over -10/70°C, E/D on Pin1**
- VC-709-109-frequency= LVDS, +3.3V, ±20ppm over -10/70°C, E/D on Pin1**
- VC-709-110-frequency= LVPECL, +2.5V, ±20ppm over -10/70°C, E/D on Pin1**
- VC-709-111-frequency= LVDS, +2.5V, ±20ppm over -10/70°C, E/D on Pin1**

## PCI Express Ordering Information

### VC-709- PCIE2 - 100M000000

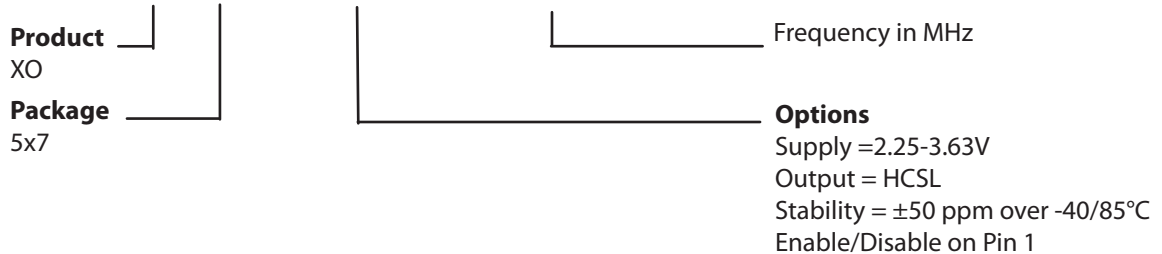

## For Additional Information, Please Contact

### USA:

Vectron International  
267 Lowell Road  
Hudson, NH 03051  
Tel: 1.888.328.7661  
Fax: 1.888.329.8328

### Europe:

Vectron International  
Landstrasse, D-74924  
Neckarbischofsheim, Germany  
Tel: +49 (0) 3328.4784.17  
Fax: +49 (0) 3328.4784.30

### Asia:

VI Shanghai  
1589 Century Avenue, the 19th Floor  
Chamtime International Financial Center  
Shanghai, China  
Tel: 86.21.6081.2888  
Fax: 86.21.6163.3598

### Disclaimer

Vectron International reserves the right to make changes to the product(s) and or information contained herein without notice. No liability is assumed as a result of their use or application. No rights under any patent accompany the sale of any such product(s) or information.

Rev: 03/28/2011