

20 W bridge/stereo amplifier for car radio

Features

- High output power:
 - $P_o = 10 + 10 \text{ W} @ R_L = 2 \Omega$, THD = 10 %
 - $P_o = 20 \text{ W} @ R_L = 4 \Omega$, THD = 10 %.
- Protection against:
 - Output DC and AC short circuit to ground
 - Overrating chip temperature
 - Load dump voltage surge
 - Fortuitous open ground
 - Very inductive loads
- Loudspeaker protection during short circuit for one wire to ground

Description

The TDA2005 is a class B dual audio power amplifier in Multiwatt11 package specifically designed for car radio applications.

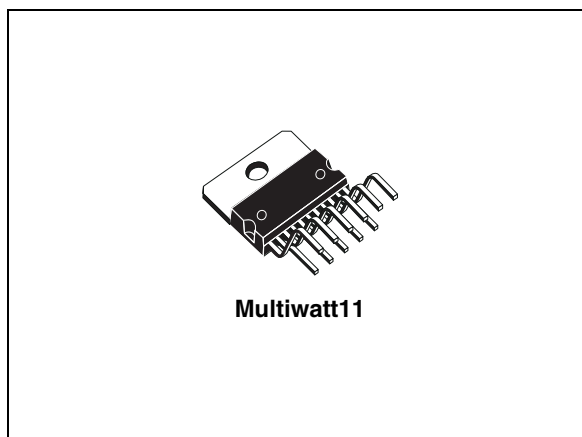

Power booster amplifiers can be easily designed using this device that provides a high current capability (up to 3.5 A) and can drive very low impedance loads (down to 1.6 Ω in stereo applications) obtaining an output power of more than 20 W (bridge configuration).

Table 1. Device summary

Order code	Package	Packing
TDA2005R	Multiwatt11	Tube
TDA2005M ⁽¹⁾	Multiwatt11	Tube
TDA2005S ⁽¹⁾	Multiwatt11	Tube

1. Do not use for New Design.

Contents

- 1 Schematic and pins connection diagrams 5**
- 2 Electrical specifications 6**
 - 2.1 Absolute maximum ratings 6
 - 2.2 Thermal data 6
 - 2.3 Bridge amplifier section 6
 - 2.3.1 Electrical characteristics (bridge application) 7
 - 2.3.2 Bridge amplifier design 9
 - 2.4 Stereo amplifier application 10
 - 2.4.1 Electrical characteristics (stereo application) 11
- 3 Application suggestion 15**
- 4 Application information 16**
 - 4.1 Built-in protection systems 20
 - 4.1.1 Load dump voltage surge 20
 - 4.1.2 Short circuit (AC and DC conditions) 21
 - 4.1.3 Polarity inversion 21
 - 4.1.4 Open ground 21
 - 4.1.5 Inductive load 21
 - 4.1.6 DC voltage 21
 - 4.1.7 Thermal shut-down 22
 - 4.1.8 Loudspeaker protection 22
- 5 Package information 23**
- 6 Revision history 24**

List of tables

Table 1.	Device summary	1
Table 2.	Absolute maximum ratings	6
Table 3.	Thermal data	6
Table 4.	Electrical characteristics (bridge application)	7
Table 5.	Bridge amplifier design	9
Table 6.	High gain vs. Rx	10
Table 7.	Electrical characteristics (stereo application)	11
Table 8.	Recommended values of the component of the bridge application circuit	15
Table 9.	Document revision history	24

List of figures

Figure 1.	Schematic diagram	5
Figure 2.	Pins connection diagram (top view)	5
Figure 3.	Test and application circuit (bridge amplifier)	6
Figure 4.	PC board and components layout of Figure 3	7
Figure 5.	Output offset voltage vs. supply voltage	8
Figure 6.	Distortion vs. output power ($R_L = 4 \Omega$)	8
Figure 7.	Distortion vs. output power ($R_L = 3.2 \Omega$)	8
Figure 8.	Bridge configuration	10
Figure 9.	Typical stereo application circuit	10
Figure 10.	Quiescent output voltage vs. supply voltage (stereo amplifier)	12
Figure 11.	Quiescent drain current vs. supply voltage (stereo amplifier)	12
Figure 12.	Distortion vs. output power (stereo amplifier)	12
Figure 13.	Output power vs. supply voltage, $R_L = 2$ and 4Ω (stereo amplifier)	12
Figure 14.	Output power vs. supply voltage, $R_L = 1.6$ and 3.2Ω (Stereo amplifier)	13
Figure 15.	Distortion vs. frequency, $R_L = 2$ and 4Ω (stereo amplifier)	13
Figure 16.	Distortion vs. frequency, $R_L = 1.6$ and 3.2Ω (stereo amplifier)	13
Figure 17.	Supply voltage rejection vs. C3 (stereo amplifier)	13
Figure 18.	Supply voltage rejection vs. frequency (stereo amplifier)	13
Figure 19.	Supply voltage rejection vs. C2 and C3, $G_V = 390/1 \Omega$ (stereo amplifier)	13
Figure 20.	Supply voltage rejection vs. C2 and C3, $G_V = 1000/10 \Omega$ (stereo amplifier)	14
Figure 21.	Gain vs. input sensitivity $R_L = 4 \Omega$ (stereo amplifier)	14
Figure 22.	Gain vs. input sensitivity $R_L = 2 \Omega$ (stereo amplifier)	14
Figure 23.	Total power dissipation and efficiency vs. output power (bridge)	14
Figure 24.	Total power dissipation and efficiency vs. output power (stereo)	14
Figure 25.	Bridge amplifier without bootstrap	16
Figure 26.	PC board and components layout of Figure 25	16
Figure 27.	Low cost bridge amplifier ($G_V = 42 \text{dB}$)	17
Figure 28.	PC board and components layout of Figure 27	17
Figure 29.	10 + 10 W stereo amplifier with tone balance and loudness control	18
Figure 30.	Tone control response (circuit of Figure 29)	18
Figure 31.	20 W bus amplifier	19
Figure 32.	Simple 20 W two way amplifier ($FC = 2 \text{ kHz}$)	19
Figure 33.	Bridge amplifier circuit suited for low-gain applications ($G_V = 34 \text{ dB}$)	20
Figure 34.	Example of muting circuit	20
Figure 35.	Suggested LC network circuit	21
Figure 36.	Voltage gain bridge configuration	21
Figure 37.	Maximum allowable power dissipation vs. ambient temperature	22
Figure 38.	Output power and drain current vs. case temperature ($R_L = 4 \Omega$)	22
Figure 39.	Output power and drain current vs. case temperature ($R_L = 3.2 \Omega$)	22
Figure 40.	Multiwatt11 mechanical data and package dimensions	23

1 Schematic and pins connection diagrams

Figure 1. Schematic diagram

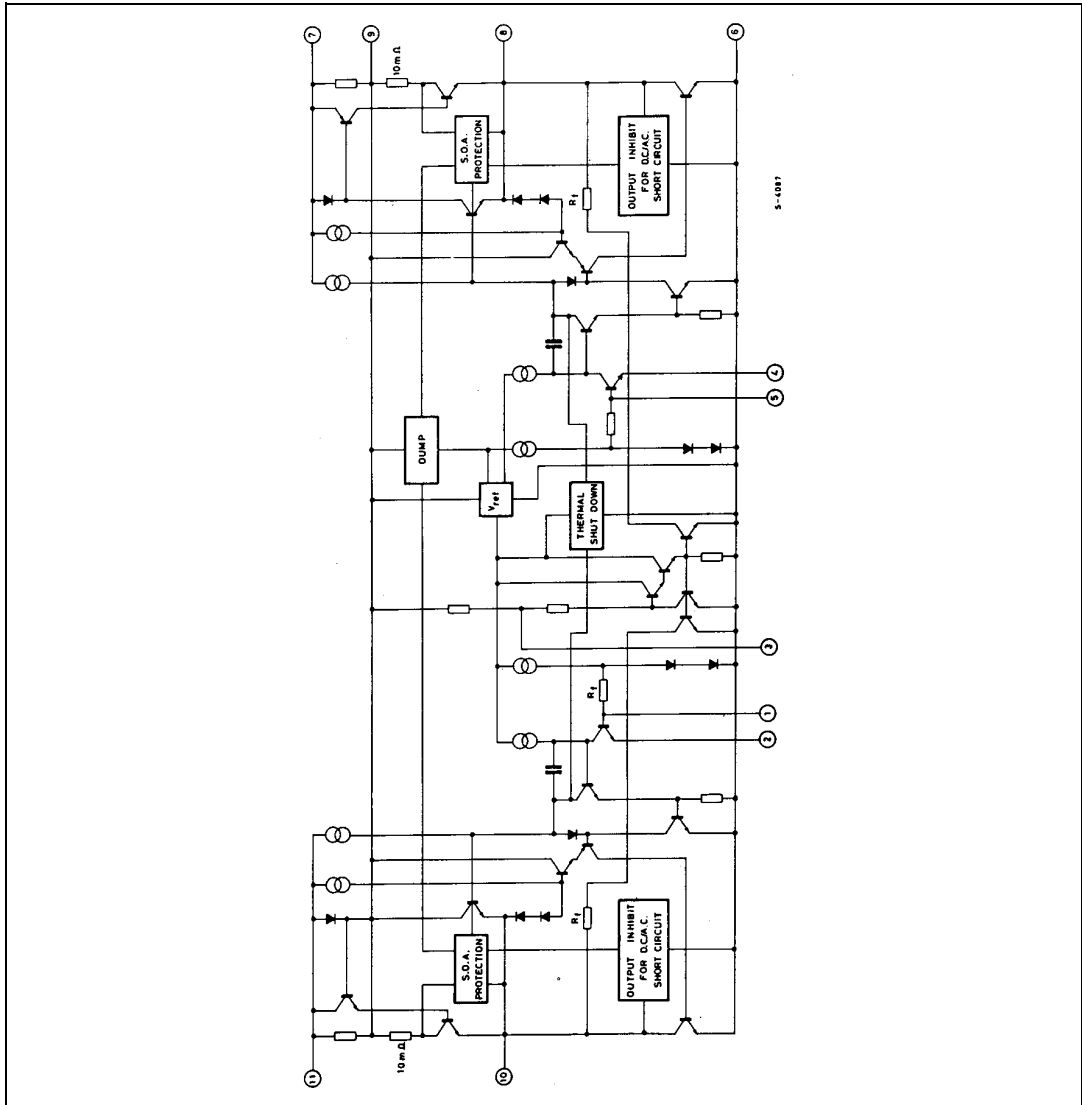
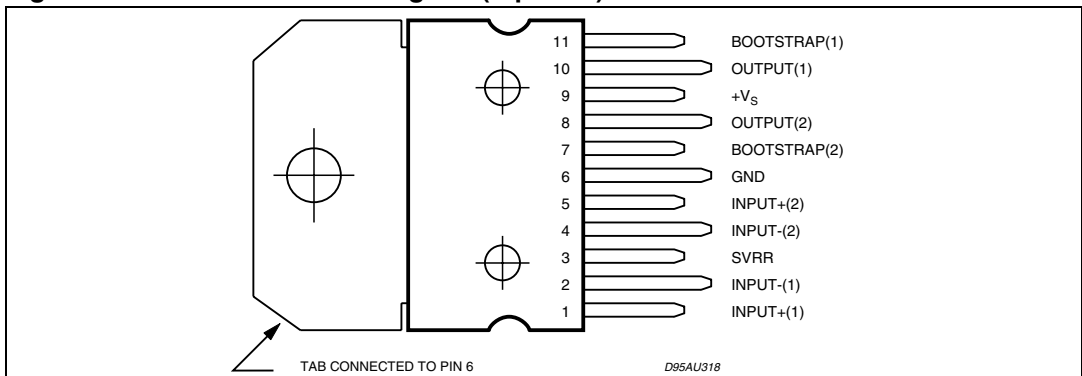

Figure 2. Pins connection diagram (top view)



2 Electrical specifications

2.1 Absolute maximum ratings

Table 2. Absolute maximum ratings

Symbol	Parameter	Value	Unit
V _S	Peak supply voltage (50 ms)	40	V
	DC supply voltage	28	
	Operating supply voltage	18	
I _o (1)	Output peak current (non repetitive t = 0.1 ms)	4.5	A
	Output peak current (repetitive f ≥10 Hz)	3.5	
P _{tot}	Power dissipation at T _{case} = 60 °C	20	W
T _{stg} , T _j	Storage and junction temperature	-40 to 150	°C

1. The max. output current is internally limited.

2.2 Thermal data

Table 3. Thermal data

Symbol	Parameter	Value	Unit
R _{th-j-case}	Thermal resistance junction-to-case	max 3	°C/W

2.3 Bridge amplifier section

Figure 3. Test and application circuit (bridge amplifier)

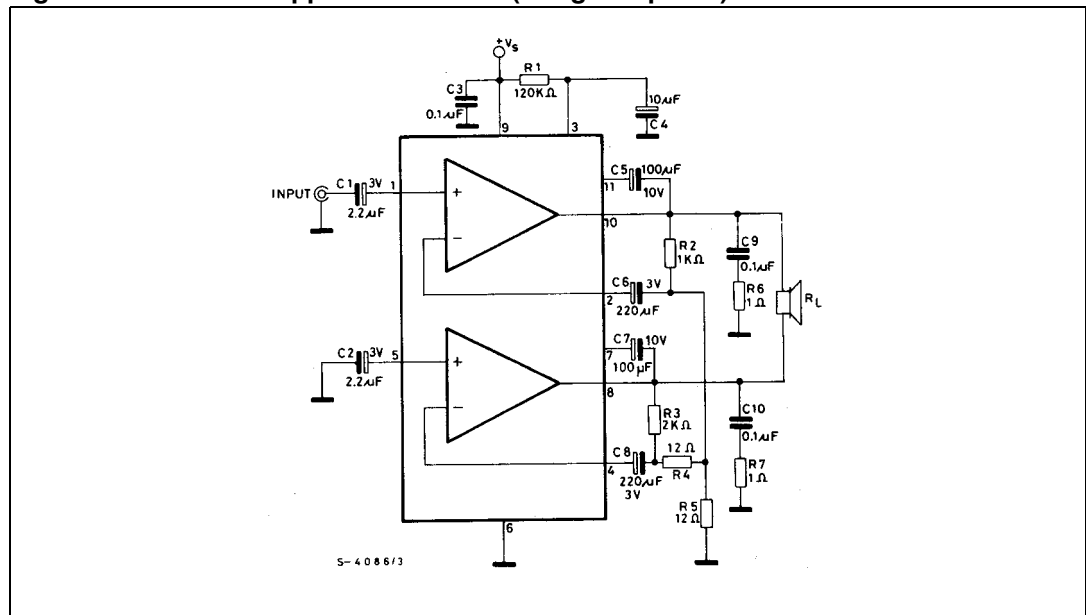
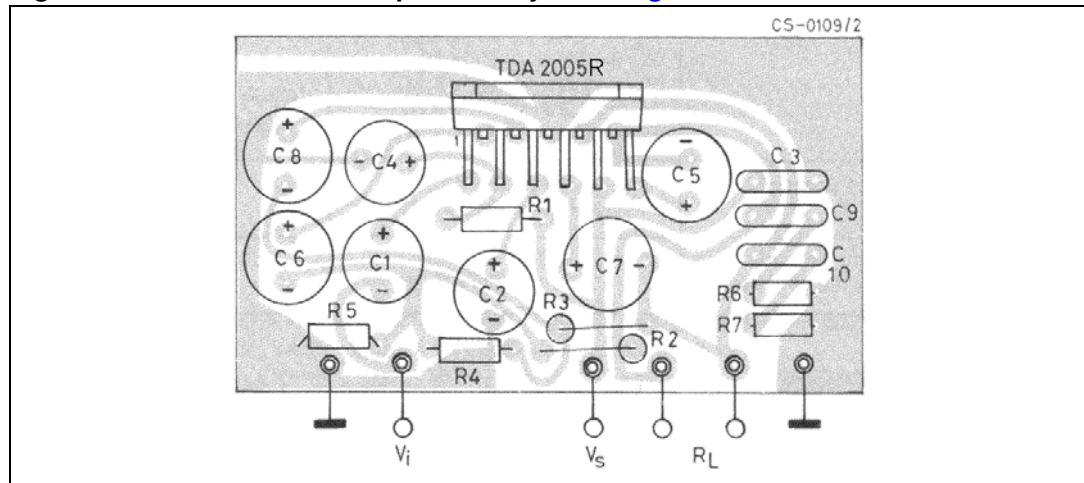

Figure 4. PC board and components layout of Figure 3



2.3.1 Electrical characteristics (bridge application)

Refer to the bridge application circuit $T_{amb} = 25^{\circ}\text{C}$; $G_v = 50\text{dB}$; $R_{th(\text{heatsink})} = 4^{\circ}\text{C/W}$ unless otherwise specified.

Table 4. Electrical characteristics (bridge application)

Symbol	Parameter	Test condition	Min.	Typ.	Max.	Unit
V_S	Supply voltage	-	8	-	18	V
V_{os}	Output offset voltage (between pin 8 and pin 10)	$V_S = 14.4\text{ V}$ $V_S = 13.2\text{ V}$	-	-	150 150	mV mV
I_d	Total quiescent drain current	$V_S = 14.4\text{ V}; R_L = 4\ \Omega$ $V_S = 13.2\text{ V}; R_L = 3.2\ \Omega$	-	75 70	150 150	mA mA
P_o	Output power	$f = 1\text{ kHz}, \text{THD} = 10\%$ $V_S = 14.4\text{ V}; R_L = 4\ \Omega$ $V_S = 14.4\text{ V}; R_L = 3.2\ \Omega$ $V_S = 13.2\text{ V}; R_L = 3.2\ \Omega$	18 20 17	20 22 19	-	W
THD	Total harmonic distortion	$f = 1\text{ kHz}; V_S = 14.4\text{ V};$ $R_L = 4\ \Omega; P_o = 50\text{ mW to } 15\text{ W};$ $f = 1\text{ kHz}; V_S = 13.2\text{ V};$ $R_L = 3.2\ \Omega; P_o = 50\text{ mW to } 13\text{ W};$	- -	- -	1 1	% %
V_i	Input sensitivity	$f = 1\text{ kHz}$ $R_L = 4\ \Omega; P_o = 2\text{ W};$ $R_L = 3.2\ \Omega; P_o = 2\text{ W}$	-	9 8	-	mW
R_i	Input resistance	$f = 1\text{ kHz}$	70	-	-	k Ω
f_L	Low frequency roll off (-3 dB)	$R_L = 3.2\ \Omega$	-	-	40	Hz
f_H	High frequency roll off (-3 dB)	$R_L = 3.2\ \Omega$	20	-	-	KHz
G_v	Closed loop voltage gain	$f = 1\text{ kHz}$	-	50	-	dB
e_N	Total Input noise voltage	$R_g = 10\ \Omega^{(1)}$	-	3	10	μV
SVR	Supply voltage rejection	$V_{\text{ripple}} = 0.5\text{ V}; f_{\text{ripple}} = 100\text{ Hz}$ $R_g = 10\text{ k}\Omega; C_4 = 10\ \mu\text{F}$	45	55	-	dB

Table 4. Electrical characteristics (bridge application) (continued)

Symbol	Parameter	Test condition	Min.	Typ.	Max.	Unit
η	Efficiency	$f = 1 \text{ kHz}; V_S = 14.4 \text{ V};$ $R_L = 4 \text{ } \Omega; P_o = 20 \text{ W};$ $R_L = 3.2 \text{ } \Omega; P_o = 22 \text{ W}$	-	60	-	%
		$f = 1 \text{ kHz}; V_S = 13.2 \text{ V};$ $R_L = 3.2 \text{ } \Omega; P_o = 19 \text{ W}$	-	58	-	
SVR	Supply voltage rejection	$f = 100 \text{ Hz}; V_{\text{ripple}} = 0.5 \text{ V};$ $R_g = 10 \text{ k}\Omega; R_L = 4 \text{ } \Omega$	30	36	-	dB
T_j	Thermal shut-down junction temperature	$f = 1 \text{ kHz}; V_S = 14.4 \text{ V};$ $R_L = 4 \text{ } \Omega; P_{\text{tot}} = 13 \text{ W}$	-	145	-	$^{\circ}\text{C}$
V_{OSH}	Output voltage with one side of the speaker shorted to ground	$V_S = 14.4 \text{ V}; R_L = 4 \text{ } \Omega$ $V_S = 13.2 \text{ V}; R_L = 3.2 \text{ } \Omega$	-	-	2	V

1. Bandwidth filter: 22 Hz to 22 kHz.

Figure 5. Output offset voltage vs. supply voltage

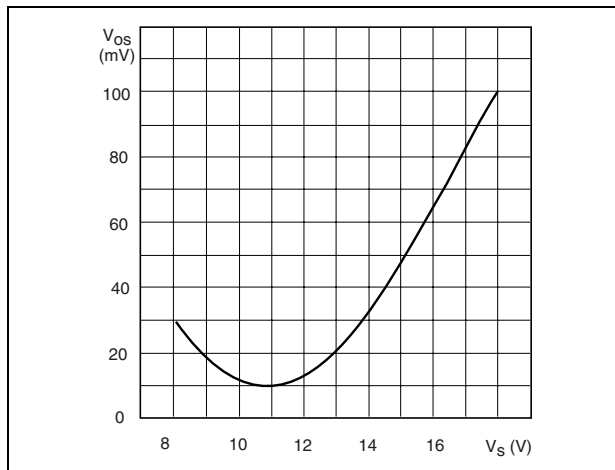

Figure 6. Distortion vs. output power ($R_L = 4 \text{ } \Omega$)

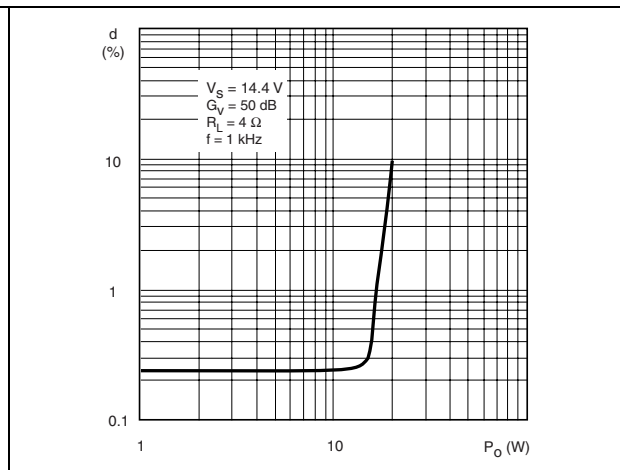
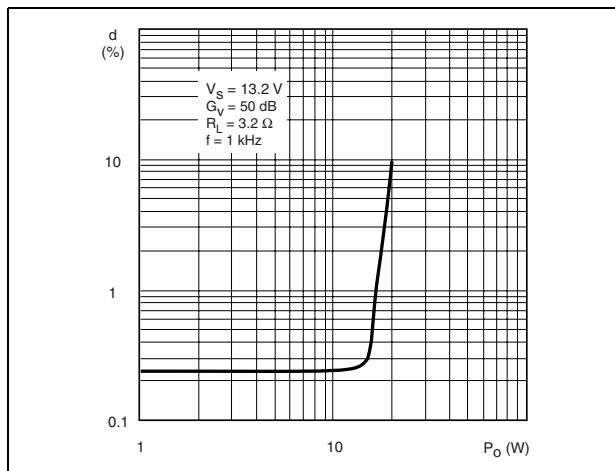

Figure 7. Distortion vs. output power ($R_L = 3.2 \text{ } \Omega$)



2.3.2 Bridge amplifier design

The following considerations can be useful when designing a bridge amplifier.

Table 5. Bridge amplifier design

Parameter		Single ended	Bridge
$V_{o\ max}$	Peak output voltage (before clipping)	$\frac{1}{2}(V_s - 2V_{CEsat})$	$V_s - 2V_{CEsat}$
$I_{o\ max}$	Peak Output current (before clipping)	$\frac{1}{2} \frac{V_s - 2V_{CEsat}}{R_L}$	$\frac{V_s - 2V_{CEsat}}{R_L}$
$P_{o\ max}$	RMS output power (before clipping)	$\frac{1}{4} \frac{(V_s - 2V_{CEsat})^2}{2R_L}$	$\frac{(V_s - 2V_{CEsat})^2}{2R_L}$

Where:

$V_{CE\ sat}$ = output transistors saturation voltage

V_s = allowable supply voltage

R_L = load impedance

Voltage and current swings are twice for a bridge amplifier in comparison with single ended amplifier.

In order words, with the same R_L the bridge configuration can deliver an output power that is four times the output power of a single ended amplifier, while, with the same max output current the bridge configuration can deliver an output power that is four times the output power of a single ended amplifier, while, with the same max output current the bridge configuration can deliver an output power that is twice the output power of a single ended amplifier.

Core must be taken when selecting V_s and R_L in order to avoid an output peak current above the absolute maximum rating.

From the expression for I_{Omax} , assuming $V_s = 14.4V$ and $V_{CE\ sat} = 2V$, the minimum load that can be driven by TDA2005 in bridge configuration is:

$$R_{Lmin} = \frac{V_s - 2V_{CEsat}}{I_{Omax}} = \frac{14.4 - 4}{3.5} = 2.97\Omega$$

The voltage gain of the bridge configuration is given by (see [Figure 36](#)):

$$G_v = \frac{V_0}{V_1} = 1 + \frac{R_1}{\left(\frac{R_2 \cdot R_4}{R_2 + R_4}\right)} + \frac{R_3}{R_4}$$

For sufficiently high gains (40 to 50 dB) it is possible to put $R_2 = R_4$ and $R_3 = 2R_1$, simplifying the formula in:

$$G_v = 4 \frac{R_1}{R_2}$$

Table 6. High gain vs. Rx

G_v (dB)	R_1 (Ω)	$R_2 = R_4$ (Ω)	R_3 (Ω)
40	1000	39	2000
50	1000	12	2000

Figure 8. Bridge configuration

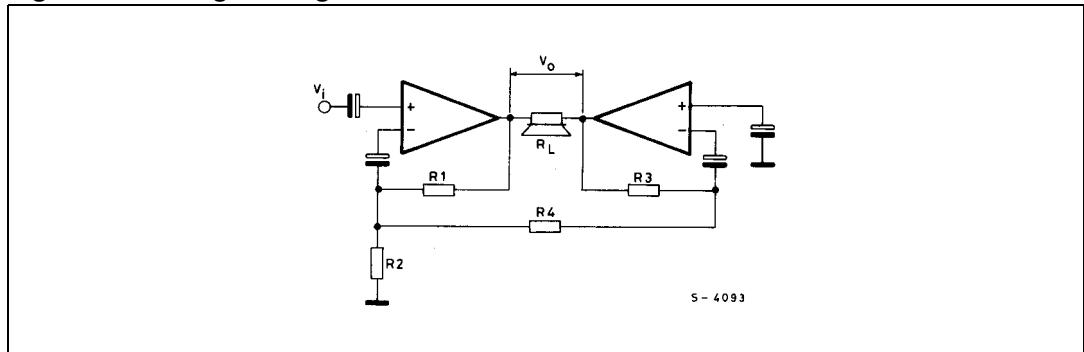

2.4 Stereo amplifier application

Figure 9. Typical stereo application circuit

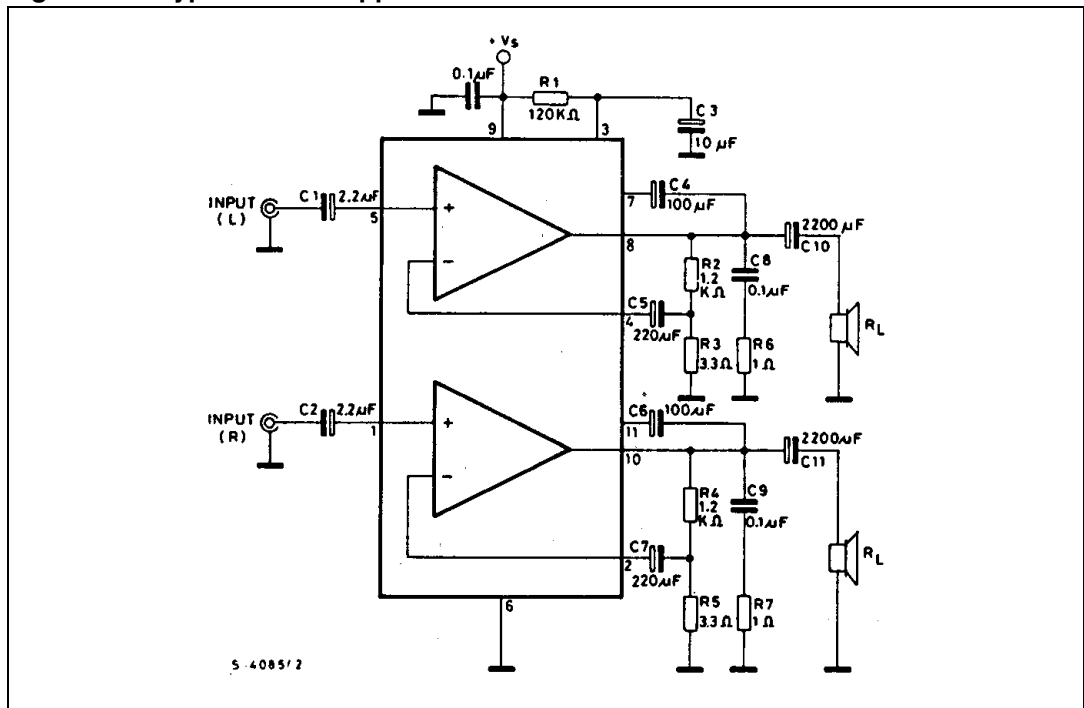

2.4.1 Electrical characteristics (stereo application)

Refer to the stereo application circuit $T_{amb} = 25\text{ }^{\circ}\text{C}$; $G_v = 50\text{ dB}$; $R_{th(heatsink)} = 4\text{ }^{\circ}\text{C/W}$ unless otherwise specified

Table 7. Electrical characteristics (stereo application)

Symbol	Parameter	Test condition	Min.	Typ.	Max.	Unit
V_S	Supply voltage		8		18	V
V_o	Quiescent offset voltage	$V_S = 14.4\text{ V}$	6.6	7.2	7.8	V
		$V_S = 13.2\text{ V}$	6	6.6	7.2	V
I_d	Total quiescent drain current	$V_S = 14.4\text{ V}$	-	65	120	mA
		$V_S = 13.2\text{ V}$		62	120	mA
P_o	Output power (each channel)	$f = 1\text{ kHz}$; THD = 10 % $V_S = 14.4\text{ V}$; $R_L = 4\text{ }\Omega$	6	6.5		W
		$V_S = 14.4\text{ V}$; $R_L = 3.2\text{ }\Omega$	7	8	-	
		$V_S = 14.4\text{ V}$; $R_L = 2\text{ }\Omega$	9	10		
		$V_S = 14.4\text{ V}$; $R_L = 1.6\text{ }\Omega$	10	11		
P_o	Output power (each channel)	$f = 1\text{ kHz}$; THD = 10 % $V_S = 13.2\text{ V}$; $R_L = 3.2\text{ }\Omega$	6	6.5		W
		$V_S = 13.2\text{ V}$; $R_L = 1.6\text{ }\Omega$	9	10	-	
		$V_S = 16\text{ V}$; $R_L = 2\text{ }\Omega$		12		
THD	Total harmonic distortion	$f = 1\text{ kHz}$; $V_S = 14.4\text{ V}$; $R_L = 4\text{ }\Omega$; $P_o = 50\text{ mW to }4\text{ W}$;	-	0.2	1	%
		$f = 1\text{ kHz}$; $V_S = 14.4\text{ V}$; $R_L = 2\text{ }\Omega$; $P_o = 50\text{ mW to }6\text{ W}$;	-	0.3	1	%
		$f = 1\text{ kHz}$; $V_S = 13.2\text{ V}$; $R_L = 3.2\text{ }\Omega$; $P_o = 50\text{ mW to }3\text{ W}$;	-	0.2	1	%
		$f = 1\text{ kHz}$; $V_S = 13.2\text{ V}$; $R_L = 1.6\text{ }\Omega$; $P_o = 40\text{ mW to }6\text{ W}$;	-	0.3	1	%
CT	Cross talk	$V_S = 14.4\text{ V}$; $V_o = 4\text{ V}_{RMS}$; $R_g = 5\text{ k}\Omega$; $R_L = 4\text{ }\Omega$;	-	60	-	mW
		$f = 1\text{ kHz}$ $f = 10\text{ kHz}$		45		mW
V_i	Input saturation voltage	-	300		-	mW
V_i	Input sensitivity	$f = 1\text{ kHz}$; $P_o = 1\text{ W}$; $R_L = 4\text{ }\Omega$;	-	6	-	mV
		$R_L = 3.2\text{ }\Omega$;		5.5		mV
R_i	Input resistance	$f = 1\text{ kHz}$	70	200	-	k Ω
f_L	Low frequency roll off (-3 dB)	$R_L = 2\text{ }\Omega$	-	-	50	Hz
f_H	High frequency roll off (-3 dB)	$R_L = 2\text{ }\Omega$	15	-	-	kHz
G_v	Open loop voltage gain	$f = 1\text{ kHz}$	-	90	-	dB
	Closed loop voltage gain	$f = 1\text{ kHz}$	48	50	51	

Table 7. Electrical characteristics (stereo application) (continued)

Symbol	Parameter	Test condition	Min.	Typ.	Max.	Unit
ΔG_V	Closed loop gain matching	-	-	0.5	-	dB
e_N	Total input noise voltage	$R_g = 10 \text{ k}\Omega^{(1)}$	-	1.5	5	μV
SVR	Supply voltage rejection	$V_{\text{ripple}} = 0.5 \text{ V}; f_{\text{ripple}} = 100 \text{ Hz}$ $R_g = 10 \text{ k}\Omega; C_3 = 10 \mu\text{F};$	35	45	-	dB
η	Efficiency	$f = 1 \text{ kHz}; V_S = 14.4 \text{ V};$ $R_L = 4 \Omega; P_o = 6.5 \text{ W};$ $R_L = 2 \Omega; P_o = 10 \text{ W};$	-	70 60	-	%
		$f = 1 \text{ kHz}; V_S = 13.2 \text{ V};$ $R_L = 3.2 \Omega; P_o = 6.5 \text{ W};$ $R_L = 1.6 \Omega; P_o = 100 \text{ W};$	-	70 60	-	%

1. Bandwidth filter: 22 Hz to 22 kHz.

Figure 10. Quiescent output voltage vs. supply voltage (stereo amplifier)

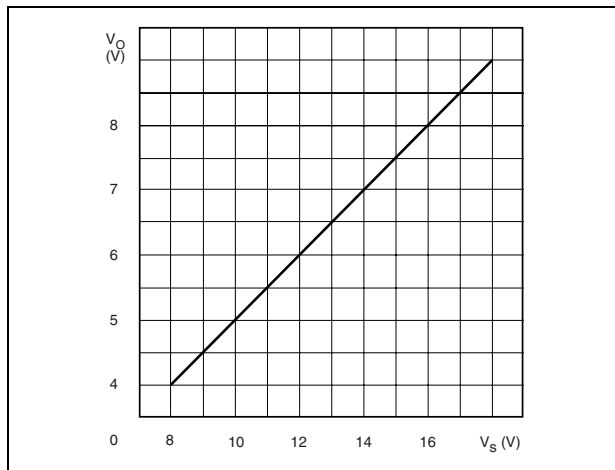

Figure 11. Quiescent drain current vs. supply voltage (stereo amplifier)

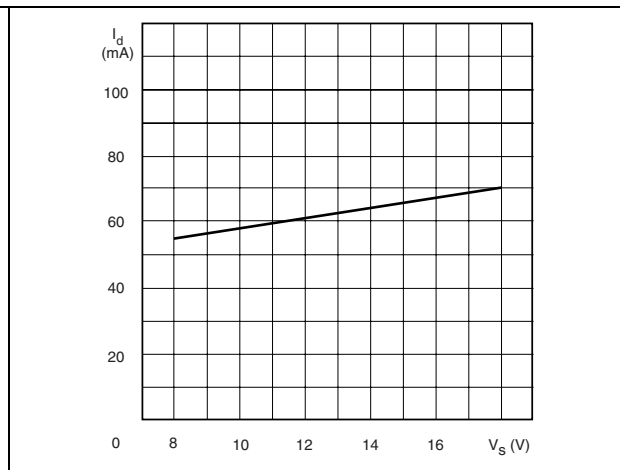

Figure 12. Distortion vs. output power (stereo amplifier)

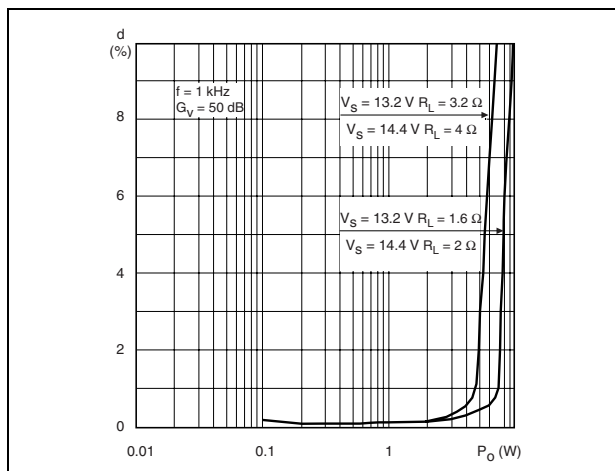

Figure 13. Output power vs. supply voltage, $R_L = 2$ and 4Ω (stereo amplifier)

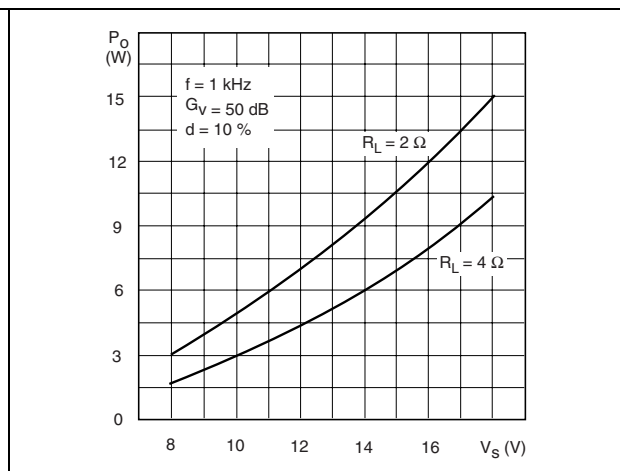

Figure 14. Output power vs. supply voltage, $R_L = 1.6$ and 3.2Ω (Stereo amplifier)

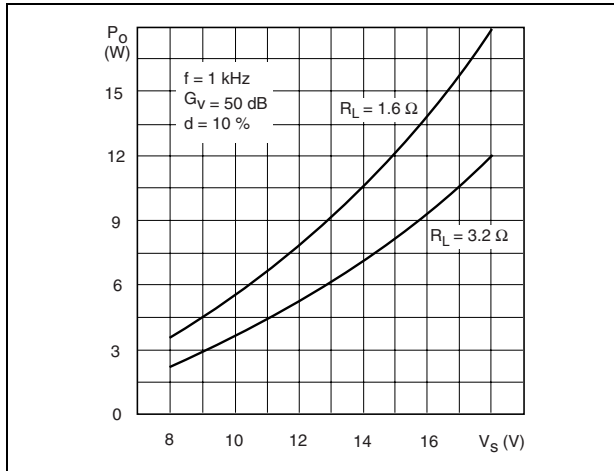

Figure 15. Distortion vs. frequency, $R_L = 2$ and 4Ω (stereo amplifier)

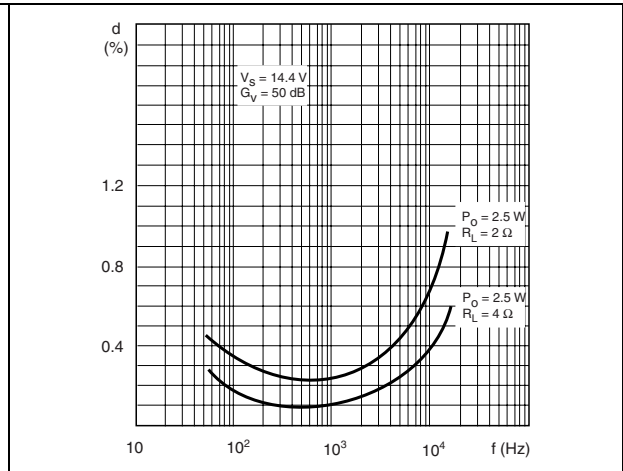

Figure 16. Distortion vs. frequency, $R_L = 1.6$ and 3.2Ω (stereo amplifier)

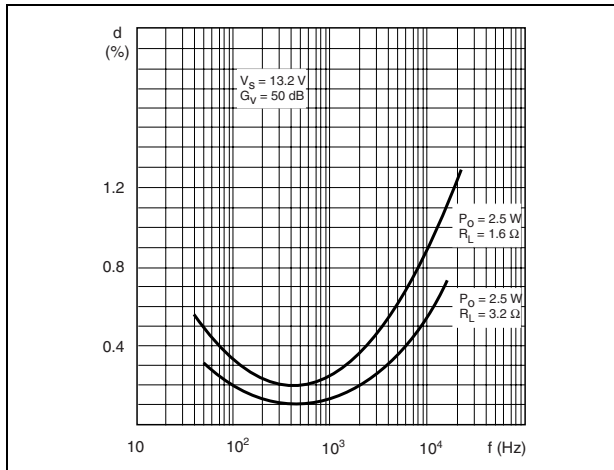

Figure 17. Supply voltage rejection vs. C_3 (stereo amplifier)

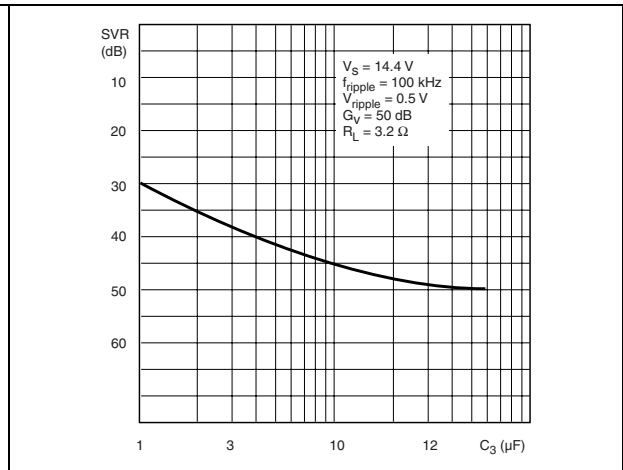

Figure 18. Supply voltage rejection vs. frequency (stereo amplifier)

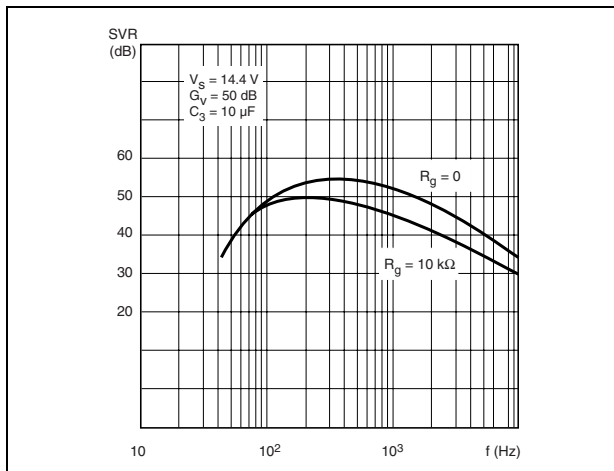

Figure 19. Supply voltage rejection vs. C_2 and C_3 , $G_V = 390/1 \Omega$ (stereo amplifier)

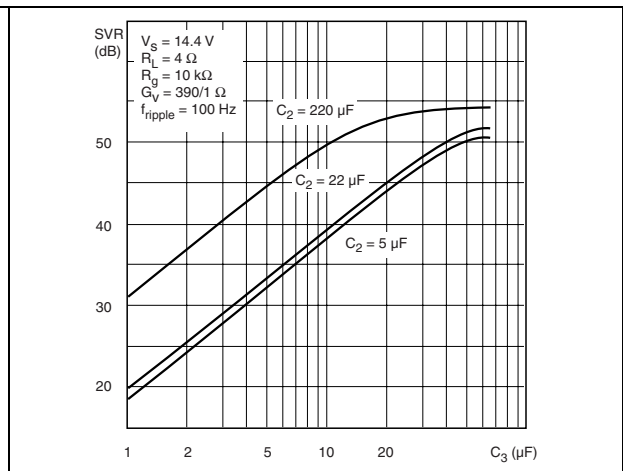

Figure 20. Supply voltage rejection vs. C2 and C3, $G_V = 1000/10\Omega$ (stereo amplifier)

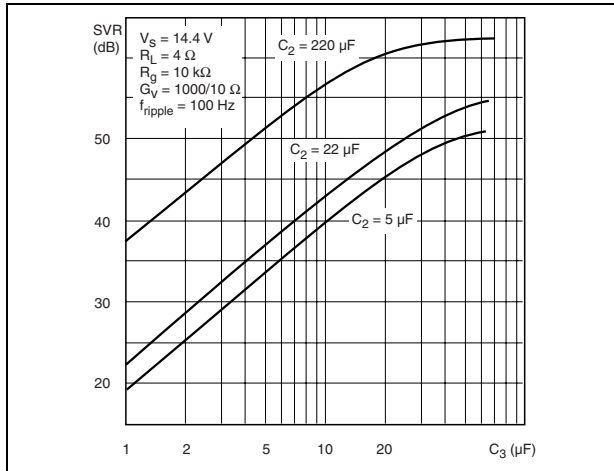

Figure 21. Gain vs. input sensitivity $R_L = 4 \Omega$ (stereo amplifier)

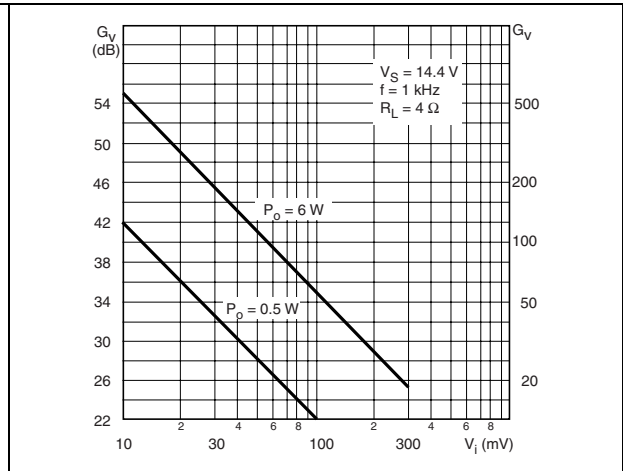

Figure 22. Gain vs. input sensitivity $R_L = 2 \Omega$ (stereo amplifier)

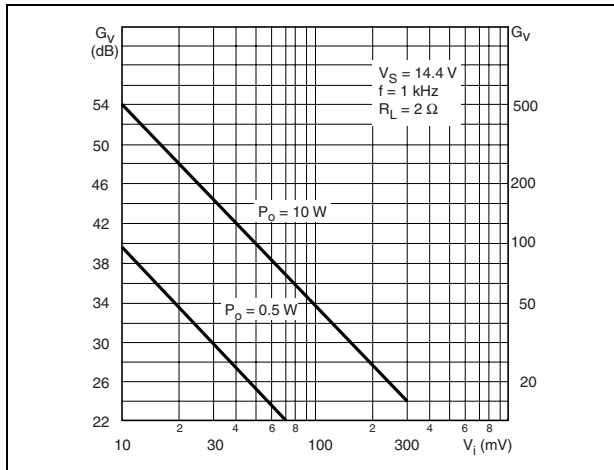

Figure 23. Total power dissipation and efficiency vs. output power (bridge)

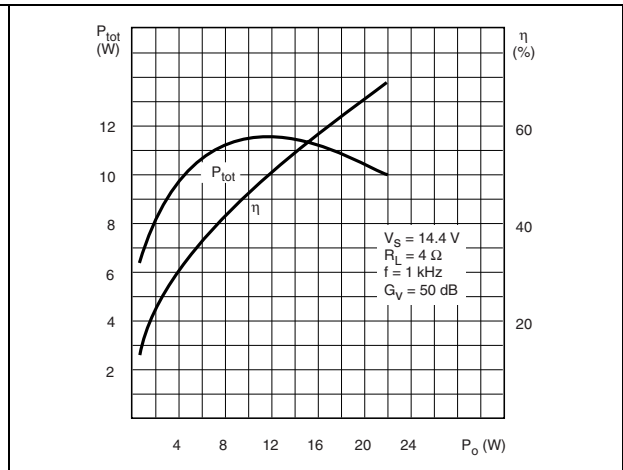
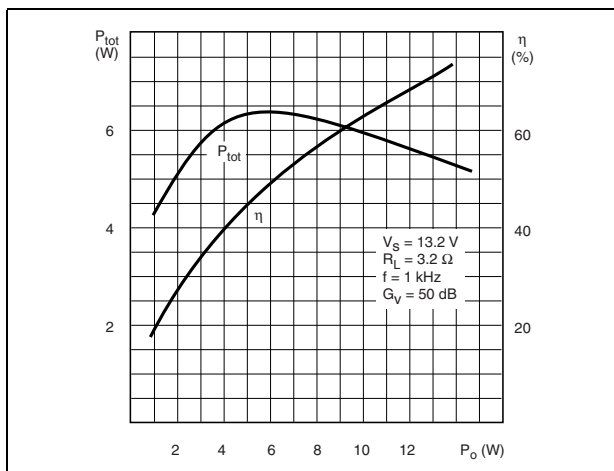

Figure 24. Total power dissipation and efficiency vs. output power (stereo)



3 Application suggestion

The recommended values of the components are those shown on bridge application circuit of [Figure 3](#). Different values can be used; the following table can help the designer.

Table 8. Recommended values of the component of the bridge application circuit

Component	Recommended value	Purpose	Larger than	Smaller than r
C1	2.2 μ F	Input DC decoupling	-	-
C2	2.2 μ F	Optimization of turn on Pop and turn on Delay	High turn on delay	High Turn on Pop, Higher low frequency cutoff Increase of Noise
C3	0.1 μ F	Supply bypass	-	Danger of oscillation
C4	10 μ F	Ripple rejection	Increase of SVR, Increase of the Switch-on Time	Degradation of SVR
C5, C7	100 μ F	Bootstrapping	-	Increase of distortion at low frequency
C6, C8	220 μ F	Feedback input DC decoupling, low frequency cut-off	-	Danger of oscillation at high frequencies with inductive loads
C9, C10	0.1 μ F	Frequency stability	-	Danger of oscillation
R1	120 k Ω	Optimization of the output symmetry	Smaller P _{omax}	Smaller P _{omax}
R2	1 k Ω	-	-	-
R3	2 k Ω	-	-	-
R4, R5	12 Ω	Closed loop gain setting (see Bridge Amplifier Design ⁽¹⁾)	-	-
R6, R7	1 Ω	Frequency stability	Danger of oscillation at high frequencies with inductive loads	-

1. The closed loop gain must be higher than 32 dB.

Figure 27. Low cost bridge amplifier ($G_V = 42\text{dB}$)

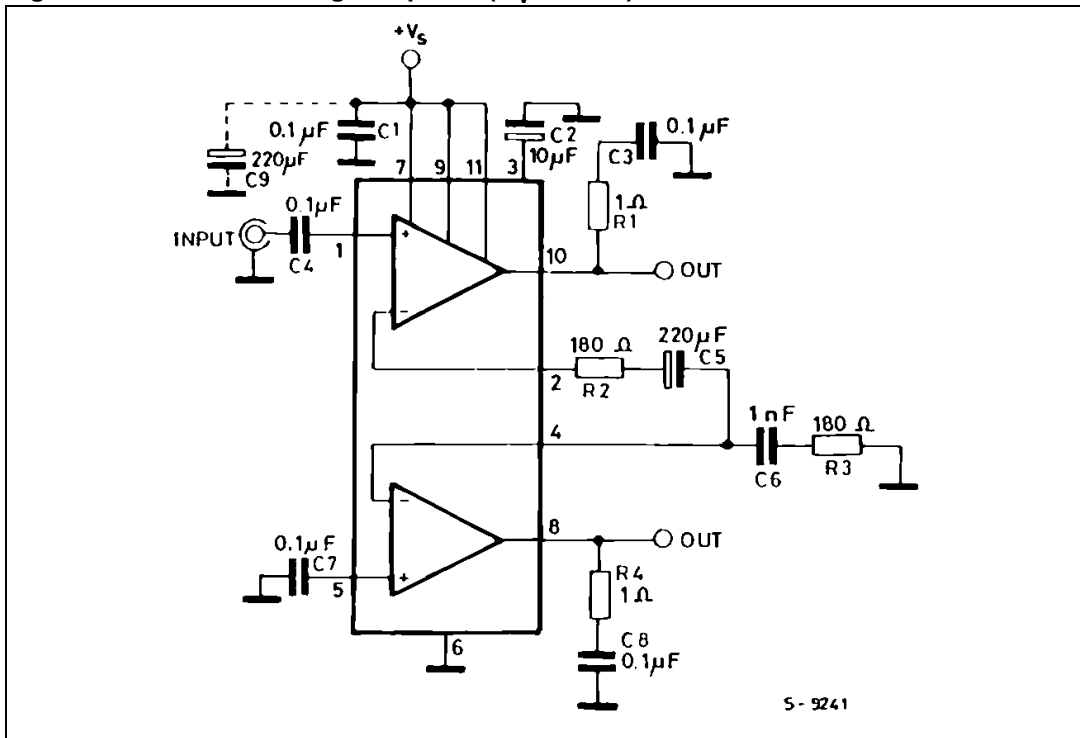

Figure 28. PC board and components layout of [Figure 27](#)

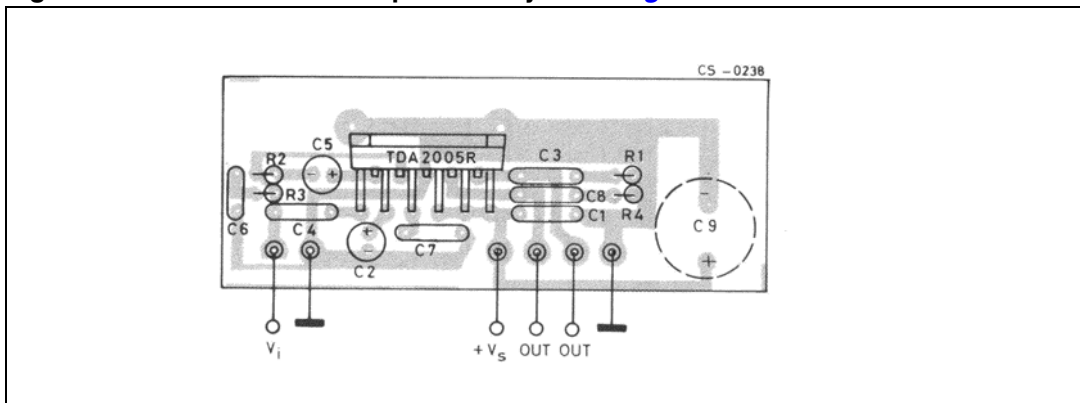

Figure 29. 10 + 10 W stereo amplifier with tone balance and loudness control

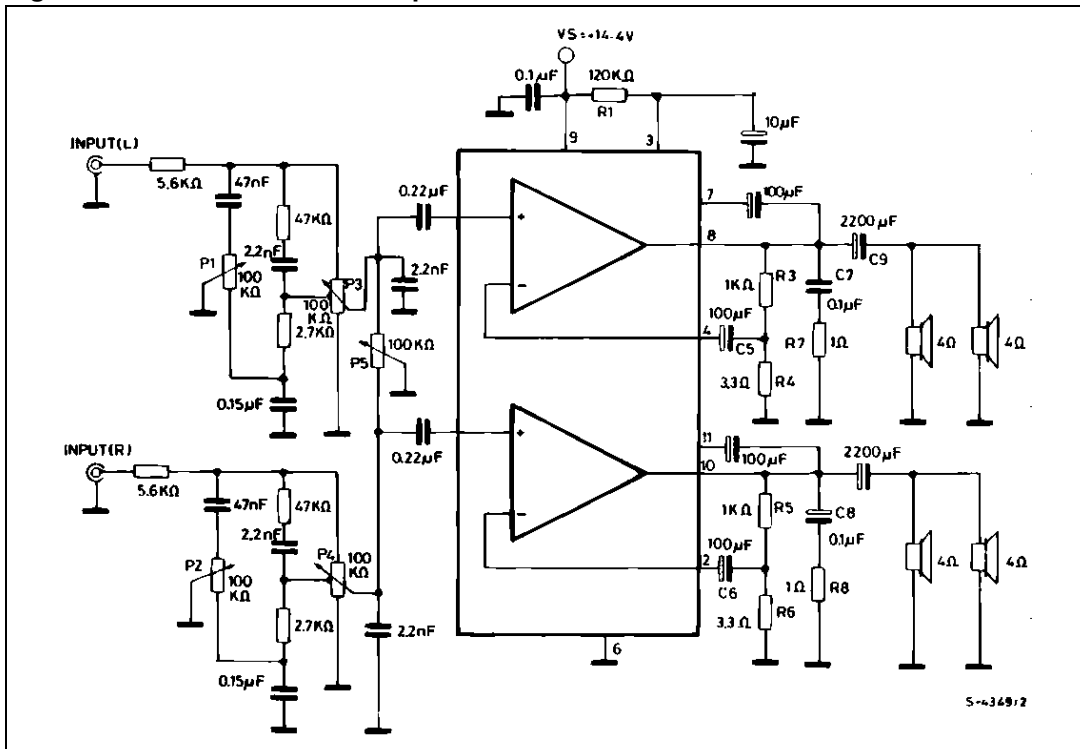

Figure 30. Tone control response (circuit of [Figure 29](#))

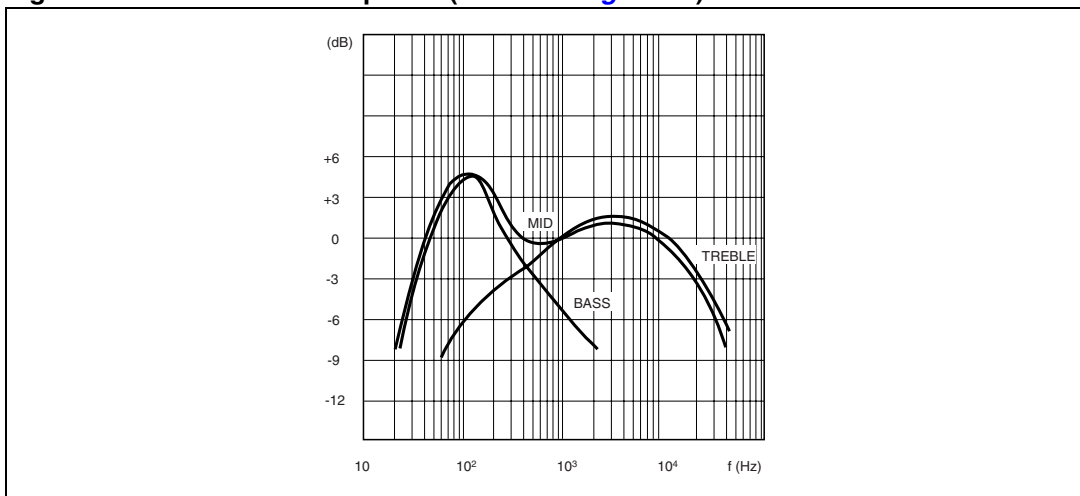

Figure 31. 20 W bus amplifier

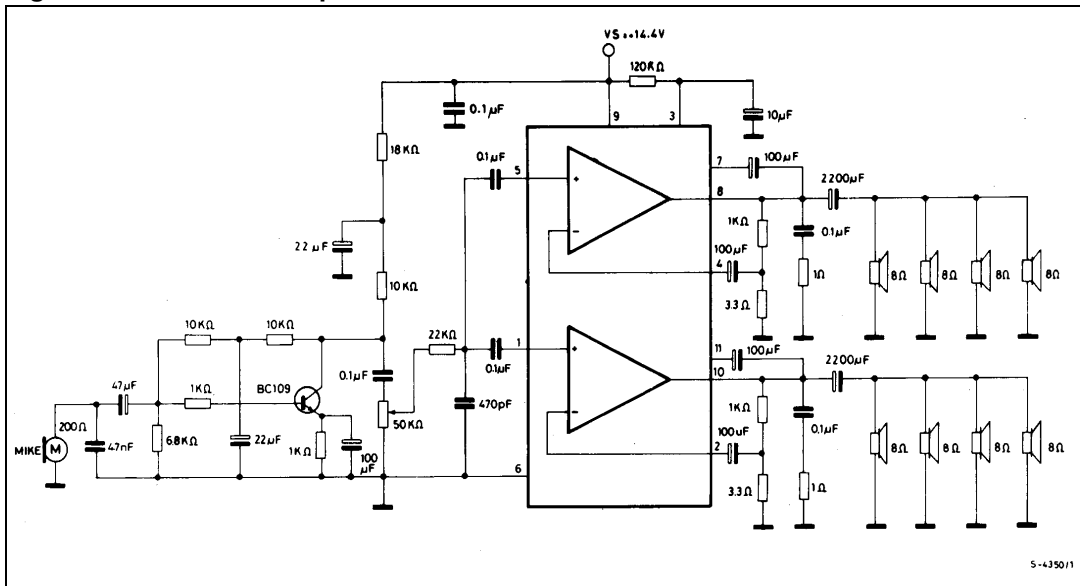

Figure 32. Simple 20 W two way amplifier ($F_C = 2 \text{ kHz}$)

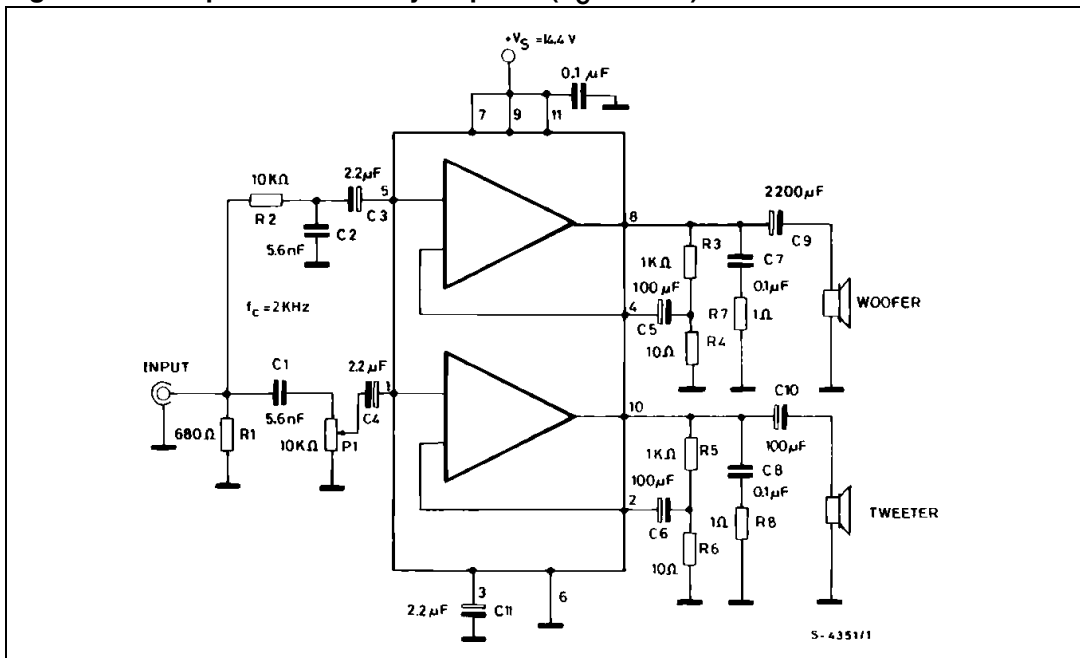

Figure 33. Bridge amplifier circuit suited for low-gain applications ($G_V = 34 \text{ dB}$)

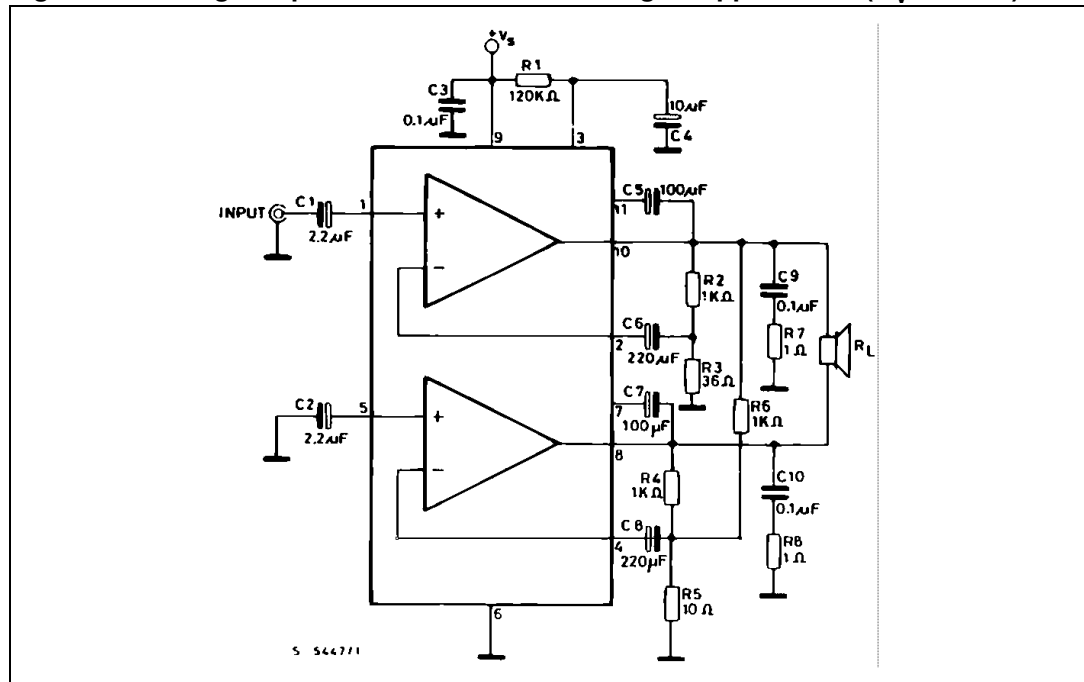
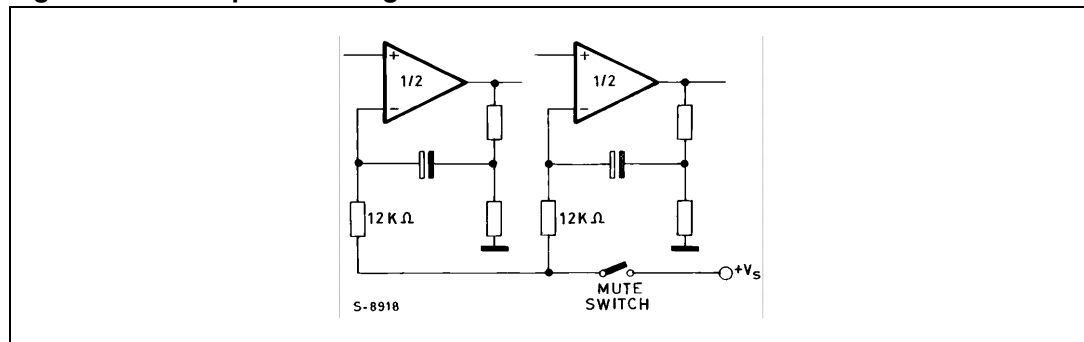

Figure 34. Example of muting circuit



4.1 Built-in protection systems

4.1.1 Load dump voltage surge

The TDA2005 has a circuit which enables it to withstand voltage pulse train, on Pin 9, of the type shown in [Figure 36](#). If the supply voltage peaks to more than 40 V, then an LC filter must be inserted between the supply and pin 9, in order to assure that the pulses at pin 9 will be held within the limits shown.

A suggested LC network is shown in [Figure 35](#). With this network, a train of pulses with amplitude up to 120 V and width of 2 ms can be applied at point A. This type of protection is ON when the supply voltage (pulse or DC) exceeds 18 V. For this reason the maximum operating supply voltage is 18 V.

Figure 35. Suggested LC network circuit

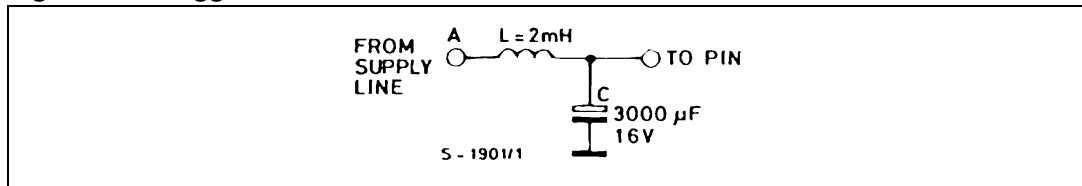
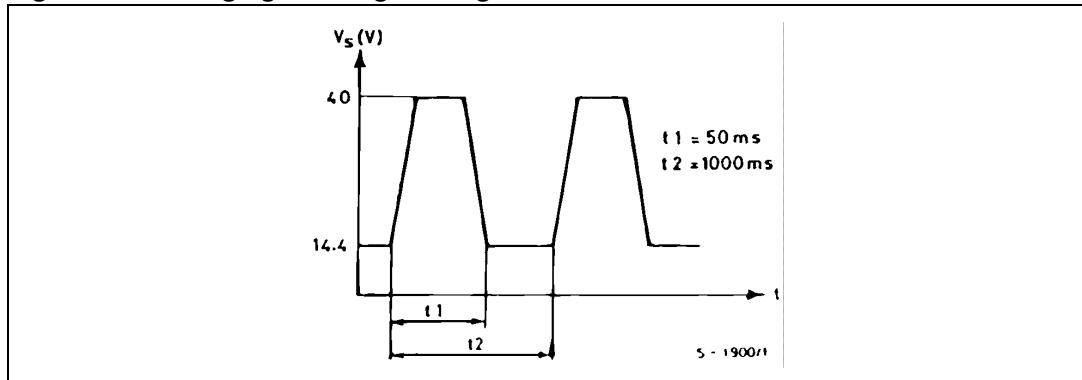

Figure 36. Voltage gain bridge configuration



4.1.2 Short circuit (AC and DC conditions)

The TDA2005 can withstand a permanent short-circuit on the output for a supply voltage up to 16 V.

4.1.3 Polarity inversion

High current (up to 10 A) can be handled by the device with no damage for a longer period than the blow-out time of a quick 2 A fuse (normally connected in series with the supply). This feature is added to avoid destruction, if during fitting to the car, a mistake on the connection of the supply is made.

4.1.4 Open ground

When the ratio is in the ON condition and the ground is accidentally opened, a standard audio amplifier will be damaged. On the TDA2005 protection diodes are included to avoid any damage.

4.1.5 Inductive load

A protection diode is provided to allow use of the TDA2005 with inductive loads.

4.1.6 DC voltage

The maximum operating DC voltage for the TDA2005 is 18 V. However the device can withstand a DC voltage up to 28 V with no damage. This could occur during winter if two batteries are series connected to crank the engine.

4.1.7 Thermal shut-down

The presence of a thermal limiting circuit offers the following advantages:

1. an overload on the output (even if it is permanent), or an excessive ambient temperature can be easily withstood.
2. the heatsink can have a smaller factor of safety compared with that of a conventional circuit. There is no device damage in the case of excessive junction temperature : all that happens is that P_o (and therefore P_{tot}) and I_d are reduced.

The maximum allowable power dissipation depends upon the size of the external heatsink (i.e. its thermal resistance); *Figure 37* shows the power dissipation as a function of ambient temperature for different thermal resistance.

4.1.8 Loudspeaker protection

The circuit offers loudspeaker protection during short circuit for one wire to ground.

Figure 37. Maximum allowable power dissipation vs. ambient temperature

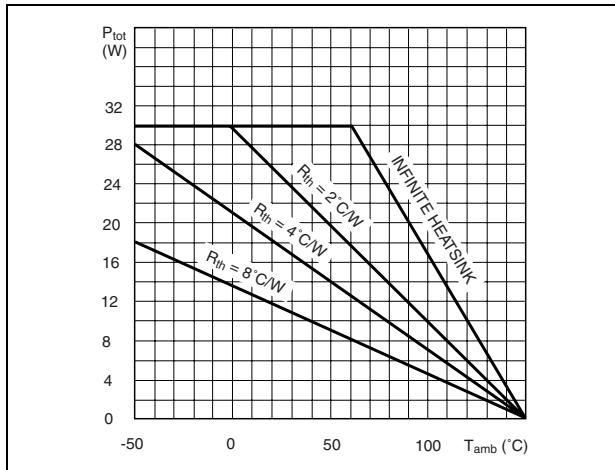

Figure 38. Output power and drain current vs. case temperature ($R_L = 4\text{ }\Omega$)

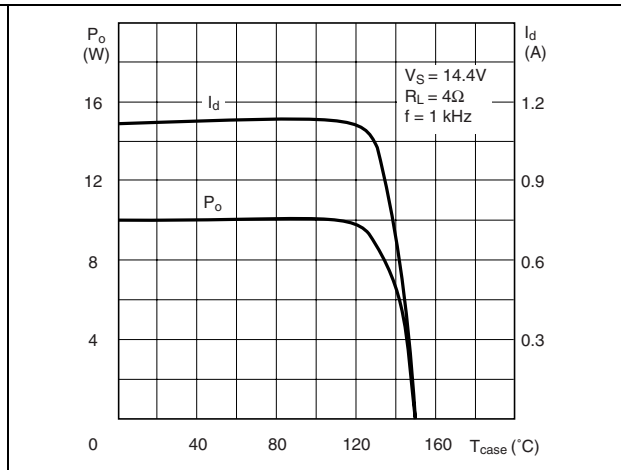
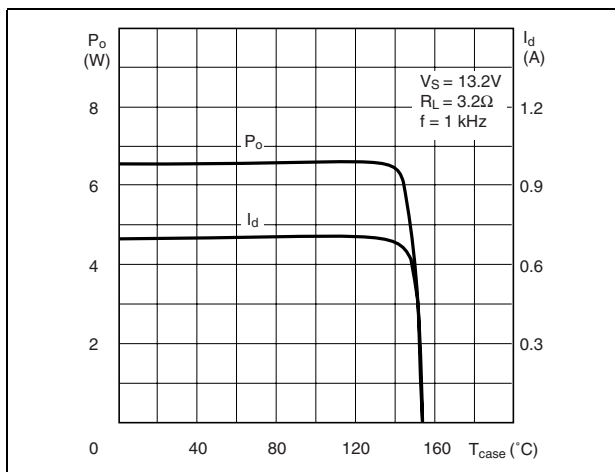

Figure 39. Output power and drain current vs. case temperature ($R_L = 3.2\text{ }\Omega$)



5 Package information

In order to meet environmental requirements, ST offers these devices in different grades of ECOPACK® packages, depending on their level of environmental compliance. ECOPACK® specifications, grade definitions and product status are available at: www.st.com.

ECOPACK® is an ST trademark.

Figure 40. Multiwatt11 mechanical data and package dimensions

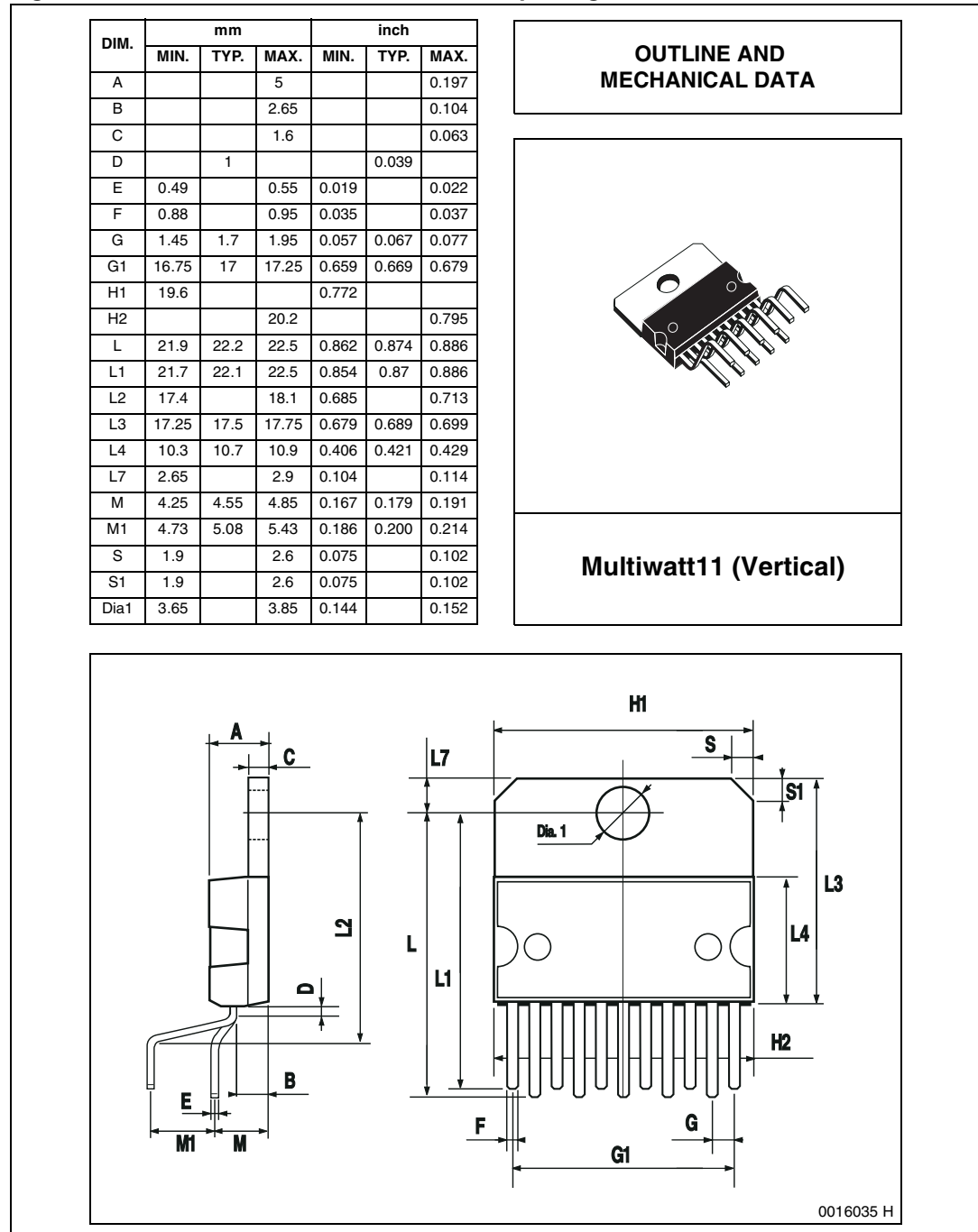

6 Revision history

Table 9. Document revision history

Date	Revision	Changes
09-Jun-1998	1	Initial release.
20-May-2000	2	Update logo.
10-Sep-2003	3	Update package drawing.
28-Jan-2010	4	Document reformatted. Updated <i>Features</i> , <i>Description</i> and <i>Table 1: Device summary</i> in cover page.

Please Read Carefully:

Information in this document is provided solely in connection with ST products. STMicroelectronics NV and its subsidiaries ("ST") reserve the right to make changes, corrections, modifications or improvements, to this document, and the products and services described herein at any time, without notice.

All ST products are sold pursuant to ST's terms and conditions of sale.

Purchasers are solely responsible for the choice, selection and use of the ST products and services described herein, and ST assumes no liability whatsoever relating to the choice, selection or use of the ST products and services described herein.

No license, express or implied, by estoppel or otherwise, to any intellectual property rights is granted under this document. If any part of this document refers to any third party products or services it shall not be deemed a license grant by ST for the use of such third party products or services, or any intellectual property contained therein or considered as a warranty covering the use in any manner whatsoever of such third party products or services or any intellectual property contained therein.

UNLESS OTHERWISE SET FORTH IN ST'S TERMS AND CONDITIONS OF SALE ST DISCLAIMS ANY EXPRESS OR IMPLIED WARRANTY WITH RESPECT TO THE USE AND/OR SALE OF ST PRODUCTS INCLUDING WITHOUT LIMITATION IMPLIED WARRANTIES OF MERCHANTABILITY, FITNESS FOR A PARTICULAR PURPOSE (AND THEIR EQUIVALENTS UNDER THE LAWS OF ANY JURISDICTION), OR INFRINGEMENT OF ANY PATENT, COPYRIGHT OR OTHER INTELLECTUAL PROPERTY RIGHT.

UNLESS EXPRESSLY APPROVED IN WRITING BY AN AUTHORIZED ST REPRESENTATIVE, ST PRODUCTS ARE NOT RECOMMENDED, AUTHORIZED OR WARRANTED FOR USE IN MILITARY, AIR CRAFT, SPACE, LIFE SAVING, OR LIFE SUSTAINING APPLICATIONS, NOR IN PRODUCTS OR SYSTEMS WHERE FAILURE OR MALFUNCTION MAY RESULT IN PERSONAL INJURY, DEATH, OR SEVERE PROPERTY OR ENVIRONMENTAL DAMAGE. ST PRODUCTS WHICH ARE NOT SPECIFIED AS "AUTOMOTIVE GRADE" MAY ONLY BE USED IN AUTOMOTIVE APPLICATIONS AT USER'S OWN RISK.

Resale of ST products with provisions different from the statements and/or technical features set forth in this document shall immediately void any warranty granted by ST for the ST product or service described herein and shall not create or extend in any manner whatsoever, any liability of ST.

ST and the ST logo are trademarks or registered trademarks of ST in various countries.

Information in this document supersedes and replaces all information previously supplied.

The ST logo is a registered trademark of STMicroelectronics. All other names are the property of their respective owners.

© 2010 STMicroelectronics - All rights reserved

STMicroelectronics group of companies

Australia - Belgium - Brazil - Canada - China - Czech Republic - Finland - France - Germany - Hong Kong - India - Israel - Italy - Japan - Malaysia - Malta - Morocco - Philippines - Singapore - Spain - Sweden - Switzerland - United Kingdom - United States of America

www.st.com