



High Speed CMOS Dual Binary 1-of-4 Decoders

QS54/74FCT139T
QS54/74FCT239T

FEATURES/BENEFITS

- QSFCT139D with 4.0 ns propagation delay
- $I_{OL} = 48$ mA COM, 32 mA MIL
- TTL-compatible input and output levels
- Mil product compliant with MIL-STD 883, Class B
- QSFCT239T has positive active outputs
- CMOS power levels < 7.5 mW static
- Available in DIP, SOIC, QSOP, HQSOP, ZIP
- JEDEC standard pinouts

DESCRIPTION

The QSFCT139T and QSFCT239T are high-speed CMOS TTL-compatible high-speed binary decoders. The QSFCT139T has negative active outputs, and the QSFCT239T has positive active outputs. The high output current I_{OL} and I_{OH} drive high-capacitance loads. All inputs have clamp diodes for undershoot noise suppression. All outputs have ground bounce suppression (see QSI Application Note AN-001), and outputs will not load an active bus when V_{CC} is removed from the device.

FUNCTIONAL BLOCK DIAGRAM

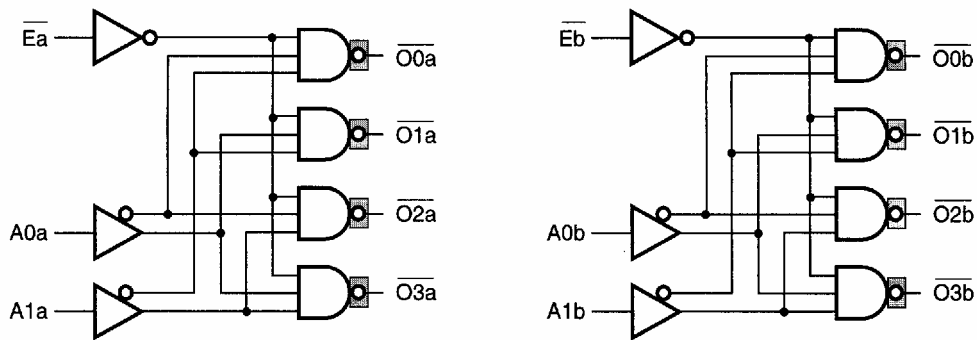

 Inverting Outputs on 139 Only
(Non-inverting Outputs on 239)

PIN CONFIGURATIONS (All Pins Top View)

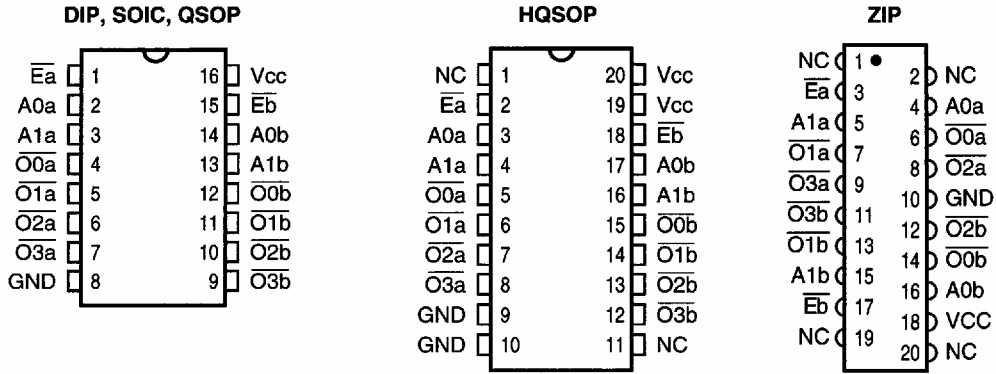

Note: Available in both 150 mil wide SOIC (package code S1) and 300 mil SOIC (package code SO).

PIN DESCRIPTION

Name	I/O	Description
Ai	I	Select Inputs
$\overline{O_i}$	O	Decode Outputs
$\overline{E_i}$	I	Enable

FUNCTION TABLE

Enable $\overline{Ea}, \overline{Eb}$	Select		FCT139 Output				FCT239 Output				Note
	A1	A0	$\overline{O3}$	$\overline{O2}$	$\overline{O1}$	$\overline{O0}$	O3	O2	O1	O0	
H	X	X	H	H	H	H	L	L	L	L	Disable Decode
L	L	L	H	H	H	L	L	L	L	H	A1-0 = 0
L	L	H	H	H	L	H	L	L	H	L	A1-0 = 1
L	H	L	H	L	H	H	L	H	L	L	A1-0 = 2
L	H	H	L	H	H	H	H	L	L	L	A1-0 = 3

ABSOLUTE MAXIMUM RATINGS

Supply Voltage to Ground	-0.5V to +7.0V
DC Output Voltage V_{OUT}	-0.5V to +7.0V
DC Input Voltage V_{IN}	-0.5V to +7.0V
AC Input Voltage (for a pulse width ≤ 20 ns)	-3.0V
DC Input Diode Current with $V_{IN} < 0$	-20 mA
DC Output Diode Current with $V_{OUT} < 0$	-50 mA
DC Output Current Max. Sink Current/Pin	120 mA
Maximum Power Dissipation	0.5 watts
T_{STG} Storage Temperature	-65° to +150°C

Note: Stresses greater than those listed under ABSOLUTE MAXIMUM RATINGS may cause permanent damage to this device resulting in functional or reliability type failures.

CAPACITANCE

$T_A = 25^\circ\text{C}$, $f = 1$ MHz, $V_{IN} = 0\text{V}$, $V_{OUT} = 0\text{V}$

Pins	SOIC	QSOP	PDIP	ZIP	Unit
1-3	4	4	5	7	pF
7, 9-12	6	6	7	9	pF
4-6, 13-15	8	8	9	10	pF

Note: Capacitance is characterized but not tested.

DC ELECTRICAL CHARACTERISTICS OVER OPERATING RANGE

Commercial $T_A = 0^\circ\text{C}$ to 70°C , $V_{CC} = 5.0\text{V} \pm 5\%$

Military $T_A = -55^\circ\text{C}$ to 125°C , $V_{CC} = 5.0\text{V} \pm 10\%$

Symbol	Parameter	Test Conditions	Min	Typ ⁽¹⁾	Max	Unit
V_{IH}	Input HIGH Voltage	Logic HIGH for All Inputs	2.0	—	—	V
V_{IL}	Input LOW Voltage	Logic LOW for All Inputs	—	—	0.8	V
ΔV_T	Input Hysteresis	$V_{TLH} - V_{THL}$ for All Inputs	—	0.2	—	V
I_{IH} I_{IL}	Input Current Input HIGH or LOW	$V_{CC} = \text{Max.}$, $0 \leq V_{IN} < V_{CC}$	—	—	5	μA
I_{OS}	Short Circuit Current	$V_{CC} = \text{Max.}$, $V_{OUT} = \text{GND}^{(2,3)}$	-60	—	—	mA
V_{IC}	Input Clamp Voltage	$V_{CC} = \text{Min.}$, $I_{IN} = -18$ mA, $T_A = 25^\circ\text{C}^{(3)}$	—	-0.7	-1.2	V
V_{OH}	Output HIGH Voltage	$V_{CC} = \text{Min.}$, $I_{OH} = -12$ mA (MIL) $I_{OH} = -15$ mA (COM)	2.4 2.4	—	—	V
V_{OL}	Output LOW Voltage	$V_{CC} = \text{Min.}$, $I_{OL} = 32$ mA (MIL) $I_{OL} = 48$ mA (COM)	— —	—	0.50 0.50	V

Notes:

1. Typical values indicate $V_{CC} = 5.0\text{V}$ and $T_A = 25^\circ\text{C}$.
2. Not more than one output should be shorted and the duration is ≤ 1 second.
3. These parameters are guaranteed by design but not tested.

POWER SUPPLY CHARACTERISTICS

Symbol	Parameter	Test Conditions ⁽¹⁾	Min	Max	Unit
I _{cc}	Quiescent Power Supply Current	V _{cc} = Max., freq = 0 0V ≤ V _{IN} ≤ 0.2V or V _{cc} -0.2V ≤ V _{IN} ≤ V _{cc}	—	1.5	mA
ΔI _{cc}	Supply Current per Input @ TTL HIGH	V _{cc} = Max., V _{IN} = 3.4V, freq = 0 ⁽²⁾	—	2.0	mA
Q _{ccd}	Supply Current per Input per MHz	V _{cc} = Max., Outputs Open and Enabled One Bit Toggling @ 50% Duty Cycle Other Inputs at GND or V _{cc} ^(3,4)	—	0.25	mA/ MHz

Notes:

- For conditions shown as Min. or Max., use the appropriate values specified under DC specifications.
- Per TTL driven input (V_{IN} = 3.4V).
- For flip-flops, Q_{ccd} is measured by switching one of the data input pins so that the output changes every clock cycle. This is a measurement of device power consumption only and does not include power to drive load capacitance or tester capacitance. This parameter is guaranteed by design but not tested.
- I_c can be computed using the above parameters as explained in the Technical Overview section.

SWITCHING CHARACTERISTICS OVER OPERATING RANGE

Commercial T_A = 0°C to 70°C, V_{cc} = 5.0V ± 5% Military T_A = -55°C to 125°C, V_{cc} = 5.0V ± 10%
C_{LOAD} = 50 pF, R_{LOAD} = 500Ω unless otherwise noted.

Symbol	Description ⁽¹⁾		139 239		139A 239A		139C 239C		139D 239D		Unit
			Min	Max	Min	Max	Min	Max	Min	Max	
t _{PHL}	Propagation Delay	Com	1.5	9	1.5	5.8	1.5	5.0	1.0	4.0	ns
t _{PLH}	A _i to \overline{O}_i	Mil	1.5	12	1.5	7.8	1.5	7.0	—	—	
t _{PHLE}	Propagation Delay	Com	1.5	9	1.5	5.9	1.5	5.0	1.0	4.0	ns
t _{PLHE}	\overline{E}_i to \overline{O}_i	Mil	1.5	12	1.5	8.0	1.5	7.0	—	—	

Notes:

- Minimums guaranteed but not tested. See Test Circuit and Waveforms.