



PS3153 / PS3154

Li Ion Smart Battery Manager Module with Safety

Features

- Standard sized modules for assembly into custom and standard sized battery packs
- Designed to work with 3cell (3153) and 4 cell (3154) series Li Ion configurations
 - Performs all major Li Ion battery management functions.
- On-board Mitsumi safety circuit provides one or two levels of safety
- Fully compliant with industry standard Smart Battery Data Specification V1.1a
 - SMBus V1.1 with PEC / CRC-8 communication with system host
- High accuracy measurement of charge / discharge current, voltage, and temperature with on-chip 14-bit integrating A/D
- Precise capacity reporting using PowerSmart patented algorithms and 3D battery cell models
- 3D models and “learned” parameters stored in on board EEPROM; fully field re-programmable via SMBus interface
- Extremely low power operation:
 - Sleep Mode: < 10 uA typical
 - Run Mode: < 500 uA typical
 - Sample Mode < 250 uA typical
- Complete hardware and software development tools available

PCB Assembly



Ordering Information

Pre-tested, fully assembled modules are available:

PS3153 – 3 cell Li Ion module
PS3154 – 4 cell Li Ion module

Quick Start

Follow these directions to assemble a pack with the PS3150 module. Use standard precautions when handling static sensitive devices.

- Modules should be connected to battery cells in the order indicated below to insure proper start-up and operation. Wires should be attached to the modules first and then connected to the battery cells as instructed.
- **The connection sequence is critical to successful use of the PS331 family of CMOS ASICs. The negative cell string connection should always be connected first, followed by the cell string positive connection. The remaining connections can then be made after the pack negative and pack positive are securely connected to the module.**

Step 1) Configure the module jumpers according to the following chart:

| | Li Ion 3-cell | Li Ion 4-cell |
|------------|----------------------|----------------------|
| R27 | Removed | Installed |
| R28 | Installed | Removed |
| R30 | Installed | Removed |

Step 2) Connect wires to module. Use large diameter wire (18AWG-20 AWG) for current carrying lines from W1 and W5. All others are signal only lines (24 to 22 AWG).

Step 3) Connect W1 (BN) to the most negative point on the battery cell stack.

Step 4) Connect W5 (BP) to the most positive point on the battery cell stack.

Step 5) Li Ion Only: Connect cell voltage pickups:

- 4 series cells - Vcell1 to W2, Vcell2 to W3, and Vcell3 W4
- 3 series cells - Vcell1 to W3, Vcell2 to W4, No Conn at W2

Step 6) Connect external connector to B-Neg, T, C, D and B-Pos .

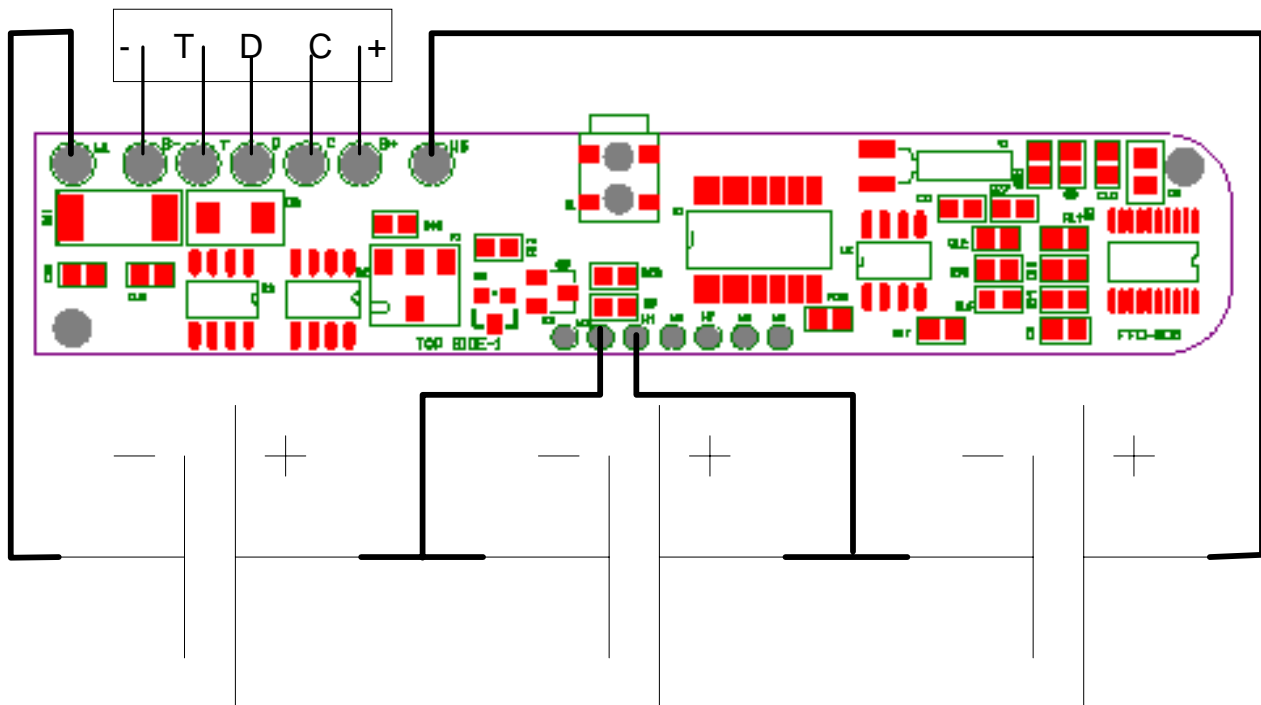

Step 7) Program the assembled pack using PowerSmart's SBTool software and calibration board or info board hardware and your *.p3I file. Default *.p3I files are available on the website (www.powersmart.com).

Step 8) Calibrate the pack using the SBTool software and calibration board hardware. The pack is now ready for use.

General Description

The PS3150 module is a SBS V1.1 compliant smart battery controller. The module is designed to operate in a battery pack consisting of three or four series connected Lithium Ion cells. The module consists of three major circuit sections - the PowerSmart PS331 SMBus fuel gauge, Mitsumi MM1253/4 based primary safety circuit and a secondary safety circuit controlled by the PS331 to provide backup to the MM1253/4.

Functional Description

P3 Fuel Gauge - The module fuel gauge provides State-of-Charge (SOC) and battery status data in accordance with the SBData and SMBus standards version 1.1. The PS331 monitors the cell voltages, battery temperature, and current to determine SOC and battery status. The PS331 also provides remaining_time, terminate_charge, and terminate_discharge alarms when the battery is fully discharged, fully charged or is under conditions of over-temperature, over-voltage or overdischarge. The State-of-Charge calculations are compensated for cell self discharge. The remaining time calculation is compensated for temperature and discharge rate. An additional correction is made in the SOC for the estimated integration errors, reported as Max_Error. The parameters for determining battery status flags and alarm thresholds are all programmable as is the battery design capacity and the battery performance model data. Please refer to the 'P3 Users Guide' and the 'PS331 Technical Data Sheet' for details on programming the P3 serial EEPROM data (programmable EEPROM data is capitalized in this text for clarity).

Primary Safety -The primary safety circuit provides cell protection from conditions of overcharge, overdischarge and overcurrent. The analog IC MM1253/4 from Mitsumi measures individual cell voltages and voltage across the discharge FET. These measures are compared against internal reference values and the gates of two P-channel power MOSFETs are controlled based on the comparison results.

Secondary Safety - The second level of safety protection is activated by Safeout (pin 21) of the PS331. This pin is activated whenever any individual cell voltage is measured above a programmable limit. An N-channel MOSFET is turned on and allows current to pass through the resistive heater section of a fuse. This heating opens the fuse, permanently disabling the pack from further charge or discharge.

Board Schematics

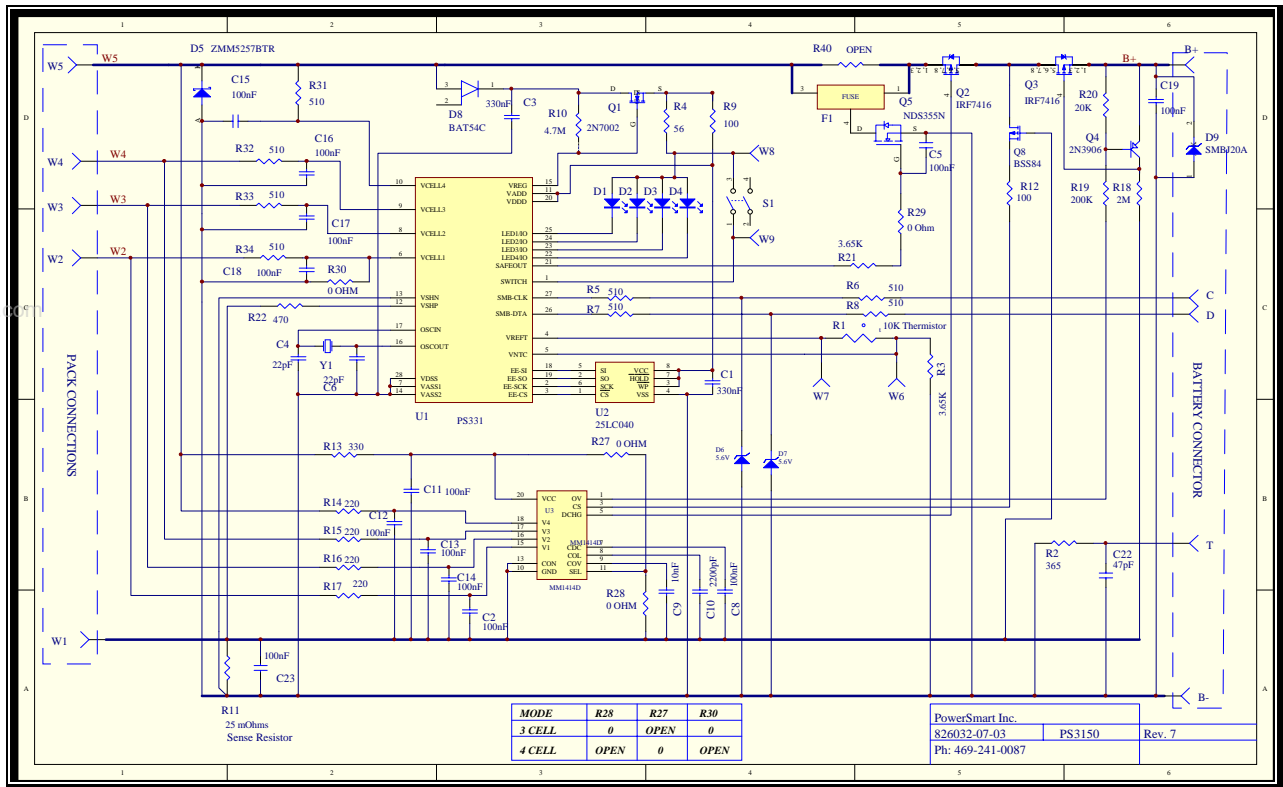

Bill of Materials

UNLESS OTHERWISE NOTED: RESISTORS ARE 5% TOLERANCE; VALUES IN OHMS
CAPACITORS ARE: C0G -- +/-5%; X7R -- +/-10%; Y5V -- +80%/-20%

| INDEX | REF. DES. | PART TYPE | VALUE | PACKAGE | QTY. | MANUFACTURER | MFR. PART NUMBER |
|-------|---|-------------|------------------------------------|--------------|------|---|---|
| 1 | | FABRICATION | | RAW BOARD | 1 | POWERSMART | B826032-07-03 |
| 2 | C1 C3 | CAPACITOR | 330nf/X7R/25V | 3216[1206] | 2 | VARIOUS | |
| 3 | C8 | CAPACITOR | 100nF/X7R/25V | 2012[0805] | 1 | VARIOUS | |
| 4 | C10 | CAPACITOR | 2.2nF/X7R/50V | 1608[0603] | 1 | VARIOUS | |
| 5 | C2 C5 C11 C12 C13 C14 C15 C16 C17 C18 C19 C23 | CAPACITOR | 100nF/Y5V/25V | 1608[0603] | 12 | VARIOUS | |
| 6 | C22 | CAPACITOR | 47pF/C0G/50V | 1608[0603] | 1 | VARIOUS | |
| 7 | C4 C6 | CAPACITOR | 22pF/C0G/50V | 1608[0603] | 2 | VARIOUS | * |
| 8 | C9 | CAPACITOR | 10nF/X7R/25V | 1608[0603] | 1 | VARIOUS | |
| 9 | D1 D2 D3 D4 | LED | CCL-LX45GT | LED\TR8 | 4 | LUMEX | CCL-LX45GT |
| 10 | D5 | ZENER DIODE | ZMM5257B | DO-213AA\PS | 3 | DIODES, INC. | ZMM5257B |
| 11 | D6 D7 | ZENER DIODE | BZX84C5V6 | SOT23 | 2 | DIODES, INC. ZETEX | BZX84C5V6 BZX84C5V6 |
| 12 | D8 | DIODE | BAT54C | SOT23 | 1 | VARIOUS | |
| 13 | D9 | TVS | SMBJ20A | SMB | 1 | DIODES, INC. CRYDOM | SMBJ20A SMBJ20A |
| 14 | F1 | FUSE (5A) | SFC1605A | FUSE\SCP | 1 | SONY CHEMICALS | SFC1605A |
| 15 | Q1 | MOSFET | 2N7002 | SOT23-GSD | 1 | VARIOUS | |
| 16 | Q2 Q3 | MOSFET | IRF7416 | SO8 | 2 | INT. RECTIFIER | IRF7416 |
| 17 | Q4 | TRANSISTOR | 2N3906 | SOT23-BEC | 1 | VARIOUS | |
| 18 | Q5 | MOSFET | NDS355N | SOT23-GSD | 1 | FAIRCHILD SEMI. | NDS355N |
| 19 | Q8 | MOSFET | 5HP01M | SOT23 | 1 | SANYO | 5HP01M |
| 20 | R1 | THERMISTOR | 10K Thermistor | 1608[0603] | 1 | SEMITEC | 103KT1608-2P |
| 21 | R10 | RESISTOR | 4.7M | 1608[0603] | 1 | VARIOUS | |
| 22 | R11 | RESISTOR | 25 mOhms (0.5%) | WSL2512 | 1 | VISHAY | WSL2512-0.025-0.5%-R86 |
| 23 | R5 R7 R13 | RESISTOR | 330 | 1608[0603] | 3 | VARIOUS | |
| 24 | R14 R15 R16 R17 | RESISTOR | 220 | 1608[0603] | 4 | VARIOUS | |
| 25 | R18 | RESISTOR | 2M | 1608[0603] | 1 | VARIOUS | |
| 26 | R19 | RESISTOR | 200K | 1608[0603] | 1 | VARIOUS | |
| 27 | R2 | RESISTOR | 365 (1%) | 1608[0603] | 1 | VARIOUS | |
| 28 | R20 | RESISTOR | 20K | 1608[0603] | 1 | VARIOUS | |
| 29 | R22 | RESISTOR | 470 | 1608[0603] | 1 | VARIOUS | |
| 30 | R27 R28 R29 R30 | RESISTOR | 0 Ohm | 1608[0603] | 5 | VARIOUS | |
| 31 | R3 R21 | RESISTOR | 3.65K (1%) | 1608[0603] | 2 | VARIOUS | |
| 32 | R4 R6 R8 | RESISTOR | 56 | 1608[0603] | 3 | VARIOUS | |
| 33 | R31 R32 R33 R34 | RESISTOR | 510 | 1608[0603] | 4 | VARIOUS | |
| 34 | R9 R12 | RESISTOR | 100 | 1608[0603] | 2 | VARIOUS | |
| 35 | S1 | SWITCH | SW\EVQPS\MTG | SW\EVQPS\MTG | 1 | PANASONIC | EVQ-PSD02K |
| 36 | U1 | IC | PS331S | SSOP28 | 1 | POWERSMART | PS331S |
| 37 | U2 | IC | M25LC040 | SO8 | 1 | MICROCHIP | 25LC040-I/SN |
| 38 | U3 | IC | MM1414DV | TSOP-20A | 1 | MITSUMI | MM1414DV |
| 39 | Y1 | CRYSTAL | 32.768 KHz (100 ppm, 12-12.5pF) | XTAL\MX1 | 1 | MICROCRYSTAL EPSON SEIKO CITIZEN | MX1V-TL-32.768K- 12.5pF-100ppm C-002RX 32.7680K- A ** VT-200 12.5pF ** CMR200TB 12.5pF |

* NOTE: THESE CAPS ARE ONLY USED WHEN (1) A VERSION OF THE PS331 IC PRIOR TO VERSION 3.5 IS INSTALLED AT U1, AND
(2) AN EPSON, SEIKO, OR CITIZEN CRYSTAL IS USED IN SUCH AN ASSEMBLY.
** NOTE: EPSON AND SEIKO CRYSTALS ARE NOT SUITABLE FOR REFLOW SOLDERING -- MUST BE HAND-SOLDERED AFTER REFLOW.

Development Tool Summary

PowerSmart provides all the necessary hardware and software to enable easy tailoring of battery control algorithm parameters and cell performance models to meet specific application requirements and attain the highest accuracy available anywhere. Table 1 summarizes the development tool offering from PowerSmart to support the PS331. Please refer to the PowerSmart web site for ordering information and design documentation (including schematics) at www.powersmart.com.

Reference Documents

This data sheet provides an overview of the PS3150 Li Ion Module. It provides a detailed description of features and specifications that are unique to the PS3150. For further information on P3 device and development tool operations, please refer to the following documents available for download at www.powersmart.com:

PS331 Data Sheet

P3 Family User's Guide

Applications Notes:

- P3 Ex. Connection Diagrams

- P3 PC Board Layout Guide

- P3 Temperature Alarm Operation

- P3 Calibration Explanations

Development Tool Documentation:

- Lithium Ion Workbook Guide

- SBTool User's Guide

- P3 Eval System Data Sheet

- P3 Cal System Data Sheet

- P3 Info / Test Board Data Sheet

SBToolBox Data Sheet

Quality Control

PowerSmart, Inc., has received ISO-9001 certification through TUV Rheinland of North America, based in Newtown, Conn. ISO-9001 certification indicates that PowerSmart has met strict international standards of quality control in manufacturing systems including product design, production, training, and inspection and testing. PowerSmart received certification for a quality system for the Design and Development of Battery Control Integrated Circuits, Software, Modules, Chargers, and Systems. PowerSmart, Inc., provides smart battery and charger electronics designed for use with all battery chemistries, bringing a new level of accuracy, reliability and customization not available before with other smart battery ICs.

Notice

PowerSmart products are not authorized for use as critical components of life support devices or systems. Seller disclaims any warranty or responsibility for such usage, which shall be at buyer's sole risk, notwithstanding any prior notice to seller of such usage or intended usage.

As used herein, "life support devices or systems" are devices or systems that are intended for implant, and whose failure to perform in such function can be reasonably expected to result in significant injury to the user. A "critical component" is any component of a life support device or system whose failure to perform can reasonably be expected to cause or result in the failure of performance of a life support device or system or to adversely affect its safety or effectiveness.