

Preliminary Data Sheet
KMT32B

FEATURES

- Contactless angular position
- Ideal for harsh environments due to magnetic sensing
- Factory optimized linearity
- Low Cost
- High Accuracy
- High rotational speed up to 30,000 rpm
- Extended operating temperature range (-40 °C to +150 °C)
- Low Power
- RoHS compliant (lead free)
- SMD package

APPLICATIONS

- Absolute and incremental angle
- Angle Measurement
- Motor motion control
- Robotics
- Camera positioning
- Potentiometer replacement
- Automotive

PACKAGES

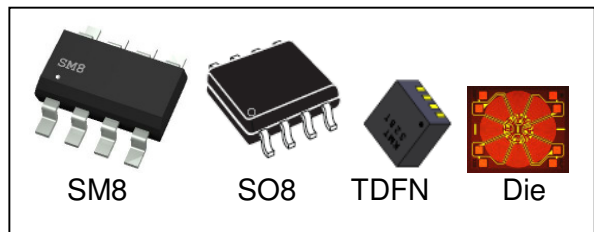

General Description

The KMT32B is a magnetic field sensor based on the anisotropic magnetoresistance effect. The sensor contains two parallel supplied Wheatstone bridges, which enclose a sensitive angle of 45 degrees.

A rotating magnetic field in the surface parallel to the chip (x-y plane) will deliver two independent sinusoidal output signals, one following a $\cos(2\alpha)$ and the second following a $\sin(2\alpha)$ function, α being the angle between sensor and field direction (see Figure 1).

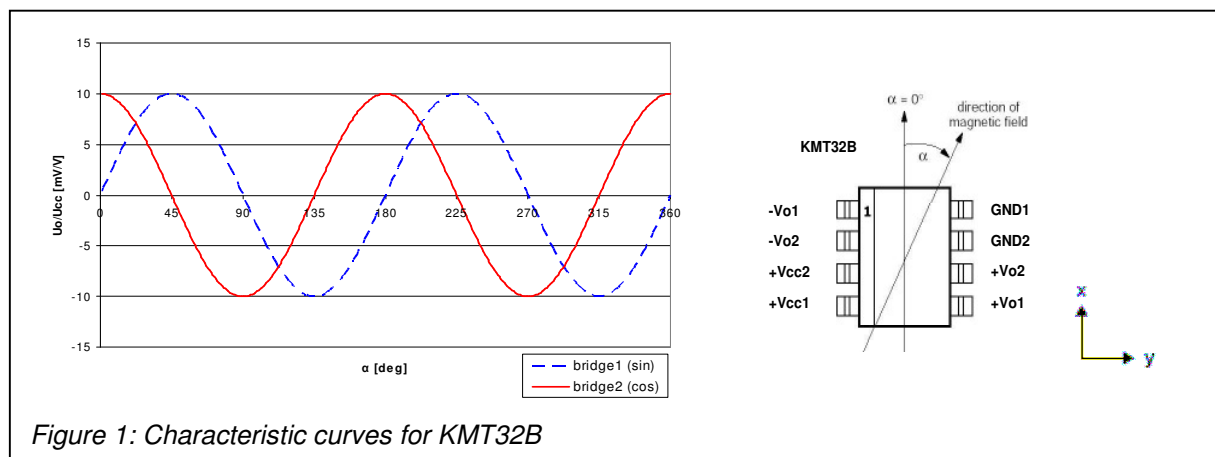
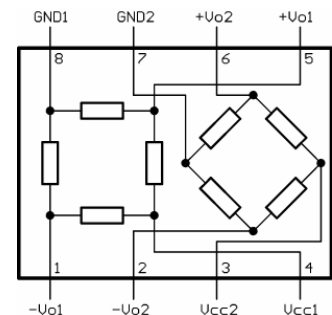
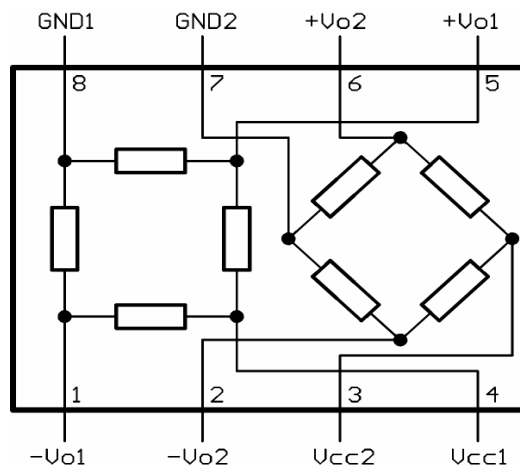

Figure 1: Characteristic curves for KMT32B

The KMT32B magnetic field sensor is suited for high precision angle measurement applications under low field conditions (regularly $H_0 = 25$ kA/m, with reduced accuracy applicable down to $H_0 = 8$ kA/m; beware of earth's magnetic field!).



Circuit Diagram

CHARACTERISTIC VALUES (PRELIMINARY)

PARAMETER	SYMBOL	CONDITION	MIN	TYP	MAX	UNIT
A. Operating Limits						
max. supply voltage	$V_{cc,max}$				10	V
max. current (single bridge)	$I_{cc,max}$				4	mA
power dissipation	P_{tot}	@T= TBD °C			TBD	mW
operating temperature	T_{op}		-40		+150	°C
storage temperature	T_{st}		-25		+150	°C
B. Sensor Specifications (T=25 °C)						
Supply voltage	V_{cc}			5	8.5	V
Resistance (single bridge)	R_b		2400	3000	3600	Ω
Output signal range	$\Delta V/V_{cc}$	Condition A, B	17	20		mV/V
Offset voltage	V_{off}	Condition A, B	-1	0	+1	mV/V
angular inaccuracy	$\Delta\alpha$	Condition A, B		0.05	0.2	deg
angular hysteresis	$\Delta\alpha H$	Condition A, B			0.1	deg
C. Sensor Specifications						
TC of amplitude	$TCSV$	Condition A, C	-0.36	-0.32	-0.28	%/K
TC of resistance	$TCBR$	Condition A, C	+0.27	+0.32	+0.37	%/K
TC of offset	TCV_{off}	Condition A, C	-4	0	+4	$\mu V/V/K$

Stress above one or more of the limiting values may cause permanent damage to the device. Exposure to limiting values for extended periods may affect device reliability.

MEASUREMENT CONDITIONS

PARAMETER	SYMBOL	UNIT	CONDITION
A. Set Up Conditions			
ambient temperature	T	°C	T = 23±5 °C (unless otherwise noted)
supply voltage	V _{cc}	V	V _{cc} =5 V
applied magnetic field	H	kA/m	H=25 kA/m
B. Sensor Specifications (T=25 °C, 360° turn , H=25 kA/m , V_omax>0, V_omin<0)			
signal amplitude	ΔV/V	mV/V	ΔV/V=V _o max - V _o min
signal offset	V _{off}	mV/V	V _{off} =V _o max + V _o min
angular hysteresis	ΔαH	deg	ΔαH = MAX α _{left turn} - α _{right turn} max. angular difference between left and right turn
angular inaccuracy	Δα	deg	Δα=MAX α ₀ -α max. angular difference between actual value α ₀ and measured angle; offset voltage error contributions not included
C. Sensor Specifications (T=-25 °C, +125 °C)			
ambient temperatures	T	°C	T ₁ =-25 °C, T ₀ =+25 °C, T ₂ =+125 °C
TC of amplitude	TC _{SV}	%/K	$TCV = \frac{1}{(T_2 - T_1)} \cdot \frac{\frac{\Delta V}{V}(T_2) - \frac{\Delta V}{V}(T_1)}{\frac{\Delta V}{V}(T_1)} \cdot 100\%$
TC of resistance	TC _{BR}	%/K	$TCR = \frac{1}{(T_2 - T_1)} \cdot \frac{R(T_2) - R(T_1)}{R(T_1)} \cdot 100\%$
TC of offset	TC _{Voff}	μV/(VK)	$TCV_{off} = \frac{V_{off}(T_2) - V_{off}(T_1)}{(T_2 - T_1)}$

PACKAGES

SM8

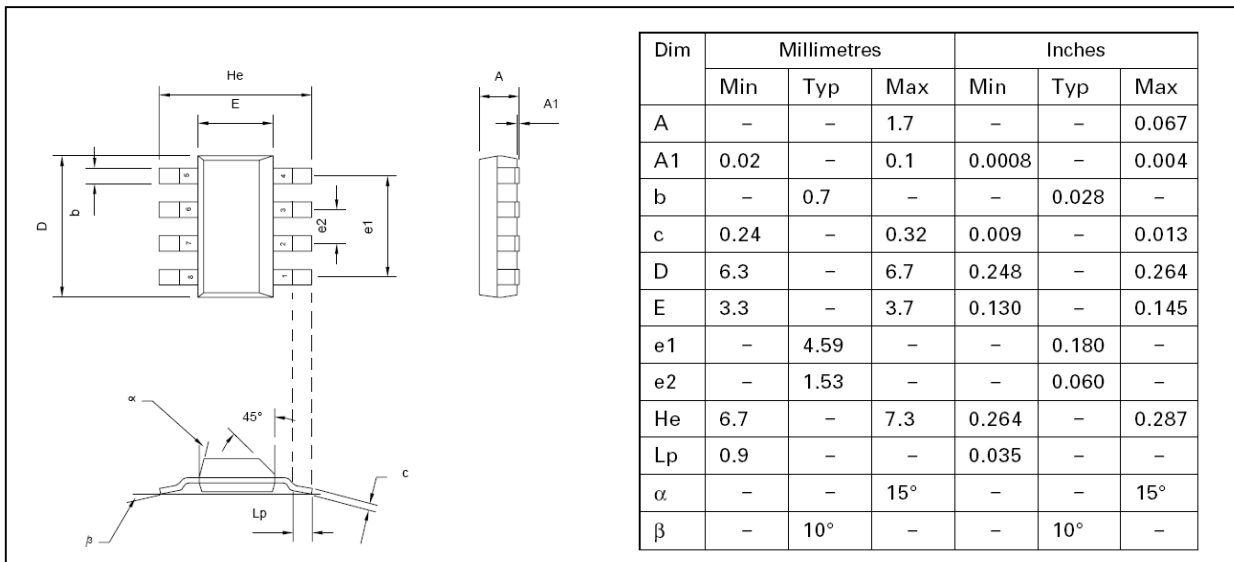

S08

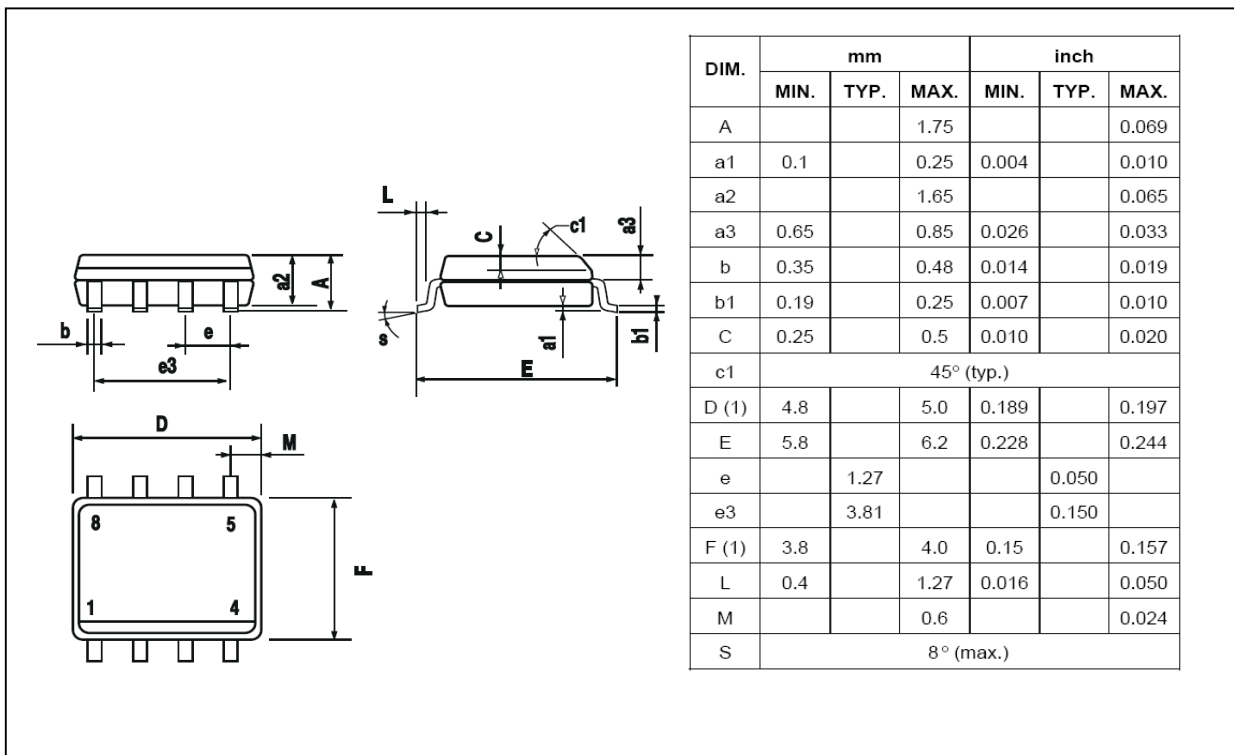

TDFN8

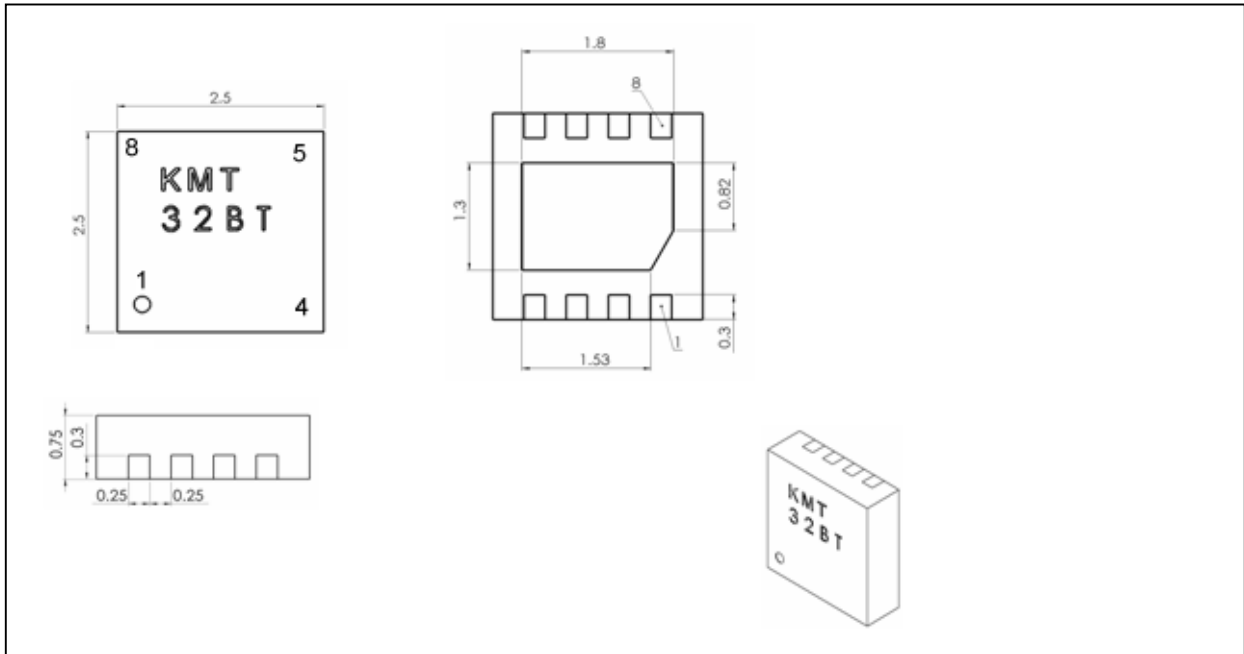

DIE

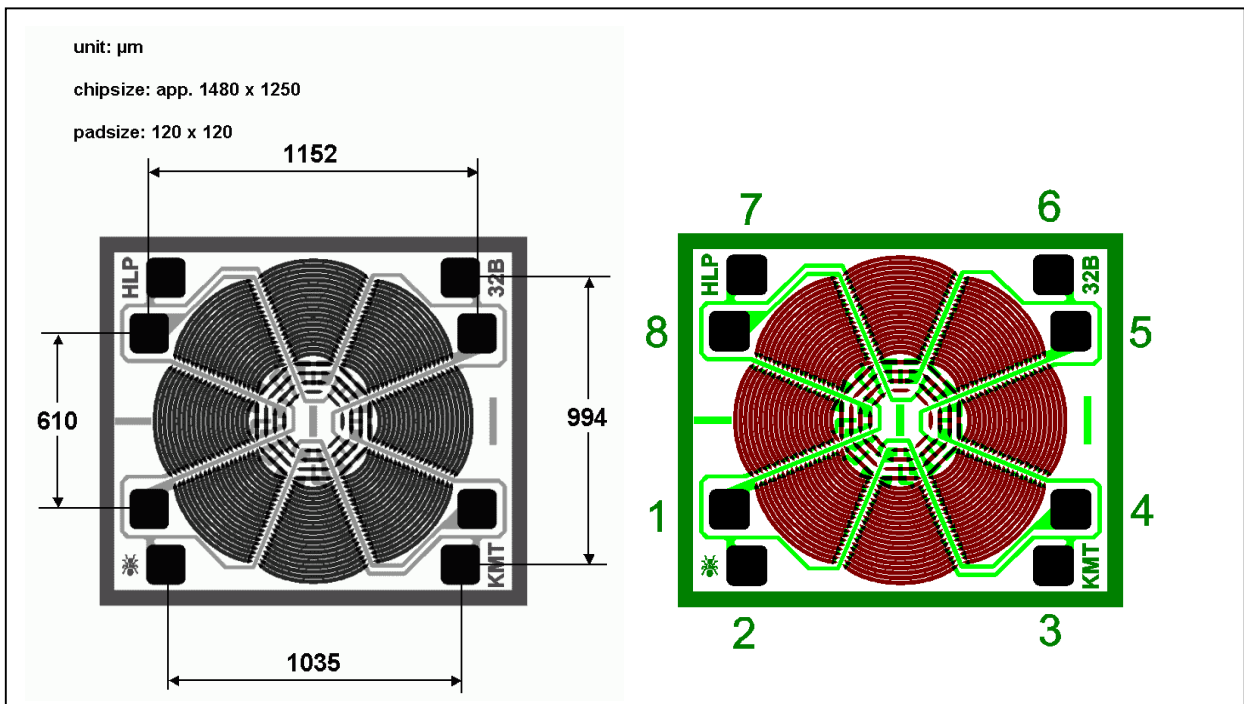

ORDERING CODE

KMT32B SO8	300130??
KMT32B SM8	30013030
KMT32B TDFN8	30013050
KMT32B chip	30013000

LEGAL DISCLAIMER

This product is not designed for use in life support appliances, devices or systems where malfunction of this product can reasonably be expected to result in personal injury. HL Planartechnik GmbH customers using or selling this product for use in such applications do so at their own risk and agree to fully indemnify HL Planartechnik GmbH for any damages resulting from such improper use or sale.

This data sheet contains target specifications for product development which may be subject to changes without notice.