

PLEASE CHECK WWW.MOLEX.COM FOR LATEST PART INFORMATION

Part Number: [0039000327](#)
Status: **Active**
Overview: [standard .062](#)
Description: 1.57mm (.062") Diameter, Standard .062" Pin and Socket Crimp Terminal, Series 1560, Male, with Tin (Sn) Plated Brass Contact, 18-24 AWG, Bag

Documents:

[Drawing \(PDF\)](#) [RoHS Certificate of Compliance \(PDF\)](#)
[Product Specification PS-1625-010 \(PDF\)](#)

General

Product Family	Crimp Terminals
Series	1560
Crimp Quality Equipment	Yes
Overview	standard .062
Product Name	Standard .062"

Physical

Gender	Male
Material - Metal	Brass
Material - Plating Mating	Tin
Material - Plating Termination	Tin
Packaging Type	Bag
Plating min: Mating (µin)	35
Plating min: Mating (µm)	0.88
Plating min: Termination (µin)	35
Plating min: Termination (µm)	0.88
Termination Interface: Style	Crimp or Compression
Wire Insulation Diameter	1.50-3.10mm (.059-.122")
Wire Size AWG	18, 20, 22, 24
Wire Size mm ²	N/A

Material Info

Old Part Number 1560TL

Reference - Drawing Numbers

Packaging Specification	SPK-1560-001
Product Specification	PS-1625-010, RPS-1625-001, RPS-5025-001
Sales Drawing	SD-1560-001



EU RoHS

ELV and RoHS Compliant
REACH SVHC Contains SVHC: No
Halogen-Free Status

China RoHS



Halogen-Free

Need more information on product environmental compliance?

Email productcompliance@molex.com
 For a multiple part number RoHS Certificate of Compliance, [click here](#)

Please visit the [Contact Us](#) section for any non-product compliance questions.

Search Parts in this Series

[1560Series](#)

Application Tooling | FAQ

Tooling specifications and manuals are found by selecting the products below. Crimp Height Specifications are then contained in the Application Tooling Specification document.

Global

Description	Product #
Hand Crimp Tool for Standard .062" Pin and Socket Crimp Terminals, 18-24 AWG	0638191300
Manual Extraction Tool	0011030002

Japan

Description	Product #
Hand Insertion Tool	0011020001
Hand Extraction Tool	0011267034

This document was generated on 05/19/2010

PLEASE CHECK WWW.MOLEX.COM FOR LATEST PART INFORMATION

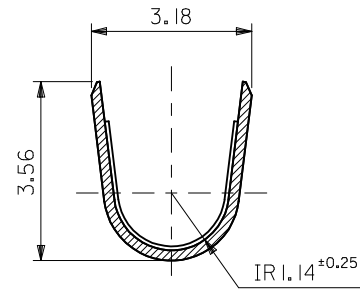
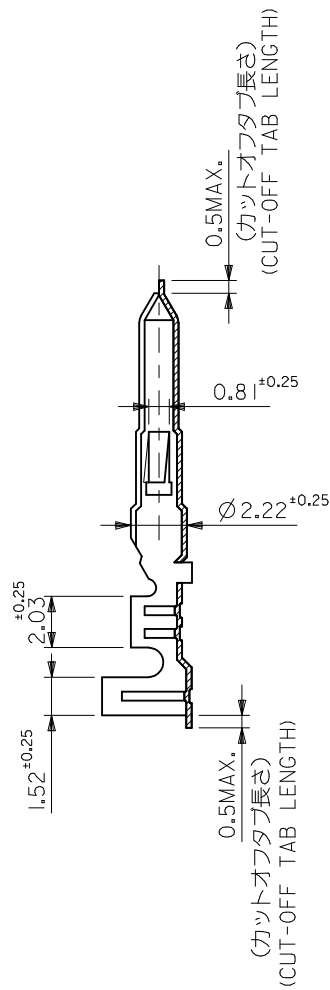
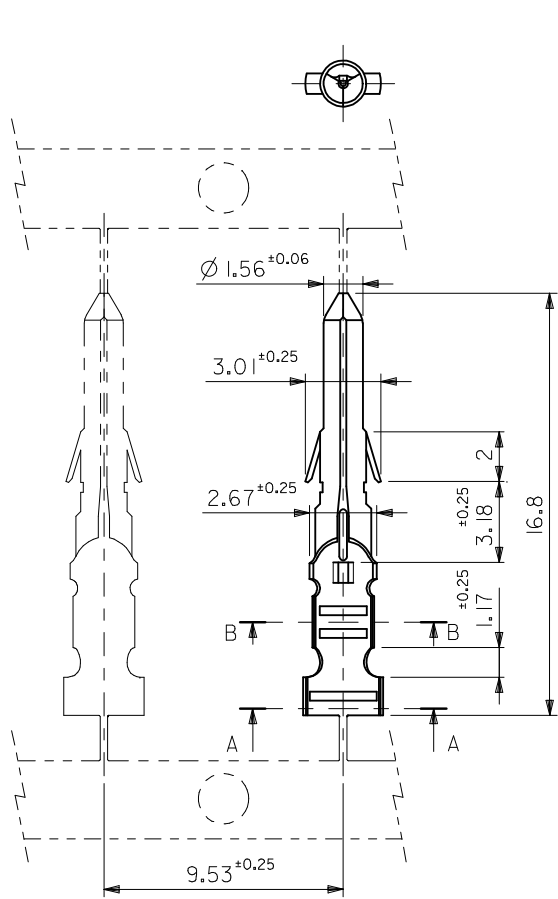

SECT. A-A
(SCALE 10 : 1)

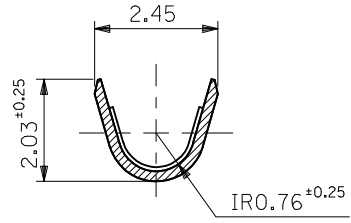

SECT. B-B
(SCALE 10 : 1)

銅 (0.5 μm MIN.) 下地 錫 (0.9 μm MIN.) TIN (0.9 μm MIN.) OVER COPPER (0.5 μm MIN.) メッキ PLATING	39-00-0327	I560TL	バラ端子 LOOSE
	39-00-0278	I560T	連鎖端子 CHAIN
	EDP.NO.	ENG.NO.	形状 FORM

MODEL NO. 1560*

注記 NOTES:

1. 一般公差 : ±0.4
GENERAL TOLERANCES: ±0.4

材料 MATERIAL 黄銅 BRASS 0.2 t
仕上げ FINISH
適用電線範囲 WIRE RANGE AWG#18-#24
被覆外径 INS. RANGE ∅1.5~3.1

REVISED EC NO: J2009-1263 DRWN:NAKAMURAA 2008/12/16 CHKD:T. HARUYAMA 2008/12/16 APPR:NUKITA 2009/01/15	DESCRIPTION	GENERAL TOLERANCES (UNLESS SPECIFIED)
	10 UNDER	± ---
	10 OVER 30 UNDER	± ---
	30 OVER	± ---
REV	DESCRIPTION	ANGULAR ± --- ° DRAFT WHERE APPLICABLE MUST REMAIN WITHIN DIMENSIONS

DIMENSION STYLE MM ONLY	SCALE 5:1	DESIGN UNITS METRIC	THIRD ANGLE PROJECTION
DRAWN BY H. HASEGAWA	DATE '93/7/9	TITLE 0.62 DIA CRIMP MALE TERM	
CHECKED BY H. HIRAMOTO	DATE '93/7/9	MOLEX INCORPORATED	
APPROVED BY M. FUKUSHIMA	DATE '93/7/9		
MATERIAL NO.	SEE TABLE	DOCUMENT NO. SD-1560-001	SHEET NO. 1 OF 1
SIZE A3	THIS DRAWING CONTAINS INFORMATION THAT IS PROPRIETARY TO MOLEX INCORPORATED AND SHOULD NOT BE USED WITHOUT WRITTEN PERMISSION		