

# AN1555N, AN1555NS

## General-use Precision Timers

### Overview

The AN1555N, and the AN1555NS are the integrated circuits designed for generating an accurate and stable timing pulse and timer time. They are widely applicable a monostable or unstable multivibrator, etc.

### Features

- Timing control microseconds to hours
- Max frequency in oscillation mode 100kHz
- High stability vs. ambient temperature and supply voltage
- TTL compatible output
- 200mA sink or source output current capability
- Reset voltage : 1.4V typ

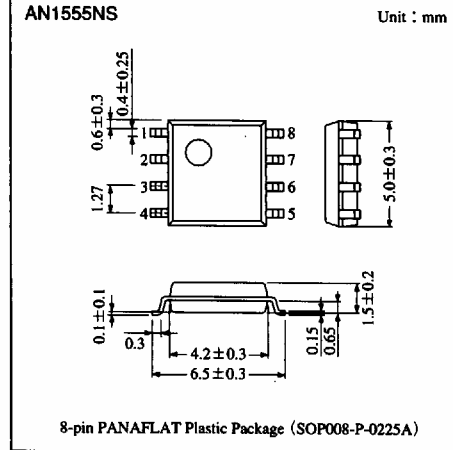
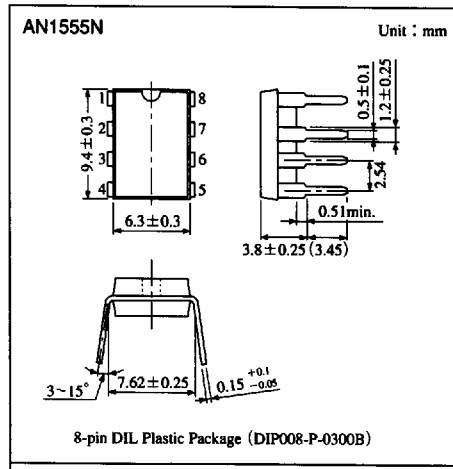

### Block Diagram

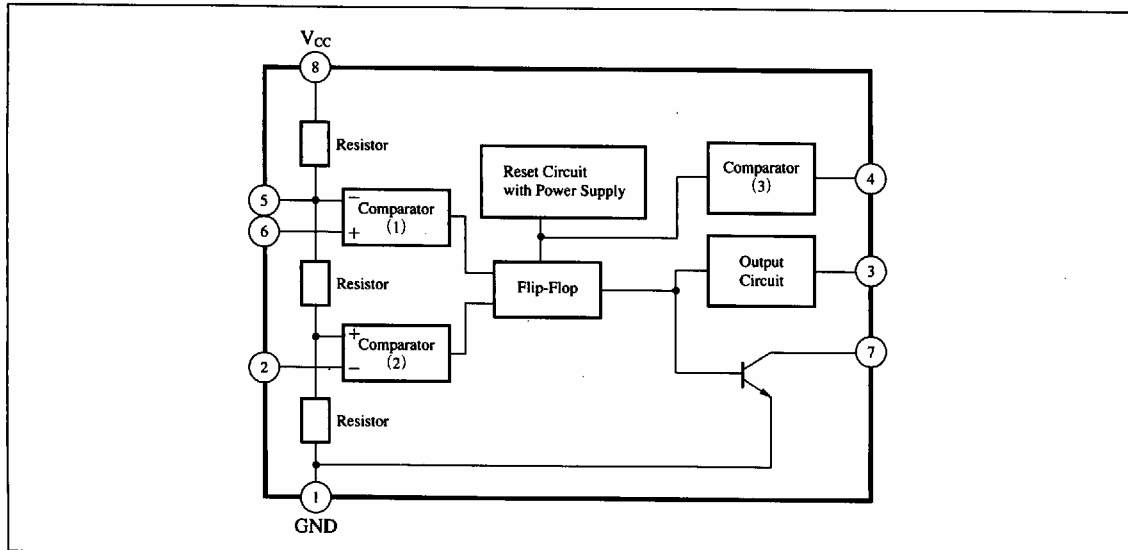

### Pin Descriptions

Pin No.	Pin name
1	GND
2	Trigger
3	Output
4	Reset
5	Control voltage
6	Threshold
7	Discharge
8	V <sub>CC</sub>

### Absolute Maximum Ratings (Ta=25°C)

Parameter	Symbol	Rating	Unit
Supply voltage	V <sub>CC</sub>	18	V
Power dissipation	AN1555N	625	mW
	AN1555NS	361	
Operating ambient temperature	T <sub>opr</sub>	-20 to +75	°C
Storage temperature	T <sub>stg</sub>	-55 to +125	°C

### Electrical Characteristics (Ta=25°C)

Parameter	Symbol	Condition	min	typ	max	Unit
Circuit current	I <sub>tot</sub>	V <sub>CC</sub> =5V, R <sub>L</sub> =∞, Output : L	—	5	7	mA
		V <sub>CC</sub> =15V, R <sub>L</sub> =∞, Output : L	—	8	12	mA
Threshold voltage	V <sub>t</sub>	V <sub>CC</sub> =5 to 15V	—	$\frac{2}{3} V_{CC}$	—	V
Threshold current	I <sub>t</sub>	V <sub>CC</sub> =5 to 15V	—	0.03	0.3	μA
Trigger voltage	V <sub>(Trigger)</sub>	V <sub>CC</sub> =5 to 15V	—	$\frac{1}{3} V_{CC}$	—	V
Trigger current	I <sub>(Trigger)</sub>	V <sub>CC</sub> =5 to 15V	—	0.1	0.5	μA
Reset voltage	V <sub>(Reset)</sub>	V <sub>CC</sub> =5 to 15V	—	1.4	2.0	V
Reset current	I <sub>(Reset)</sub>	V <sub>CC</sub> =5 to 15V	—	0.05	0.2	μA
Control voltage	V <sub>(Cont.)</sub>	V <sub>CC</sub> =5V	2.6	3.33	4.0	V
		V <sub>CC</sub> =15V	9.0	10.0	11.0	V
Output voltage "L" level	V <sub>OL</sub>	V <sub>CC</sub> =5V, I <sub>SINK</sub> : 5mA	—	0.05	0.2	V
		V <sub>CC</sub> =5V, I <sub>SINK</sub> : 8mA	—	0.08	0.25	V
		V <sub>CC</sub> =15V, I <sub>SINK</sub> : 10mA	—	0.05	0.2	V
		V <sub>CC</sub> =15V, I <sub>SINK</sub> : 50mA	—	0.2	0.5	V
		V <sub>CC</sub> =15V, I <sub>SINK</sub> : 100mA	—	0.5	2	V
		V <sub>CC</sub> =15V, I <sub>SINK</sub> : 200mA	—	2.5	—	V
Output voltage "H" level	V <sub>OH</sub>	V <sub>CC</sub> =5V, I <sub>source</sub> : 100mA	2.8	3.3	—	V
		V <sub>CC</sub> =15V, I <sub>source</sub> : 100mA	12.8	13.3	—	V
Initial time interval error	Δt <sub>E</sub>	Unstable oscillation R <sub>A</sub> , R <sub>B</sub> =1 to 100kΩ C=0.1μF	—	1.0	—	%
Time interval temperature regulation	Δt <sub>T</sub>		—	50	—	ppm/°C
Time interval supply voltage regulation	Δt <sub>V</sub>		—	0.1	—	%/V
Rise time	t <sub>r</sub>	V <sub>CC</sub> =5 to 15V	—	100	—	ns
Fall time	t <sub>f</sub>		—	100	—	ns

Note) Operating Supply Voltage Range : V<sub>CC(opr)</sub> = 4.5 to 16V

■ Characteristics Curve

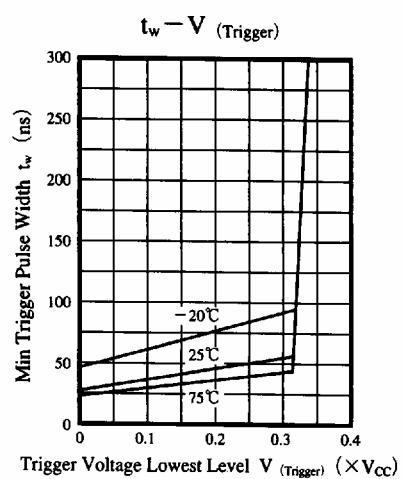
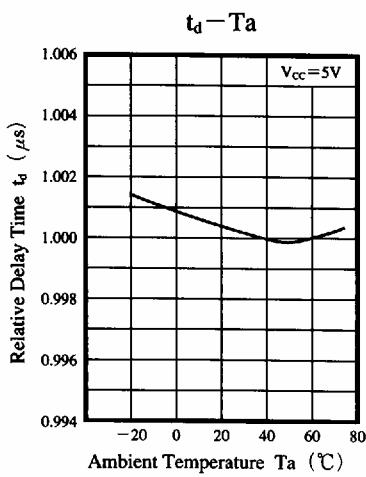
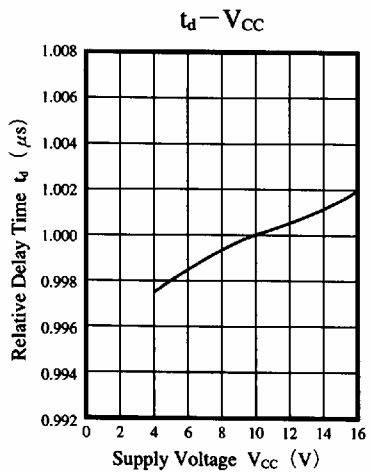
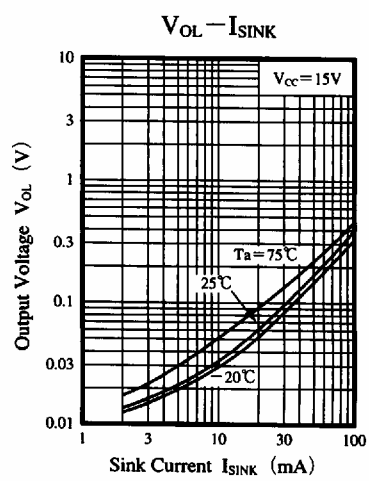
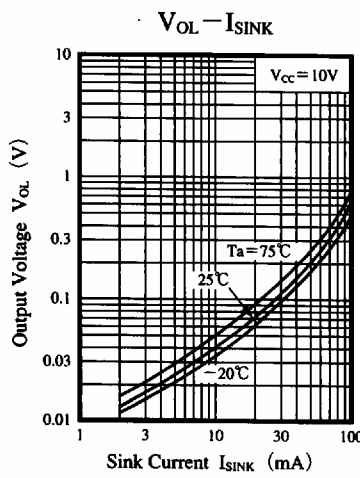
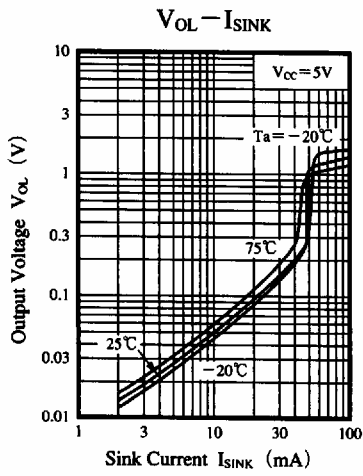
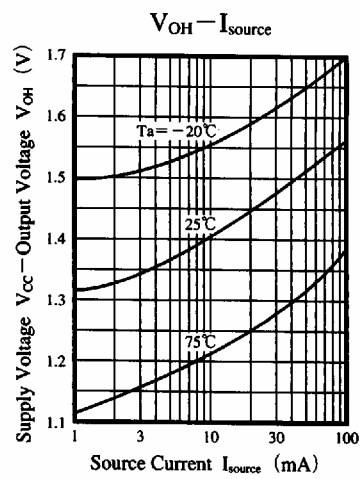
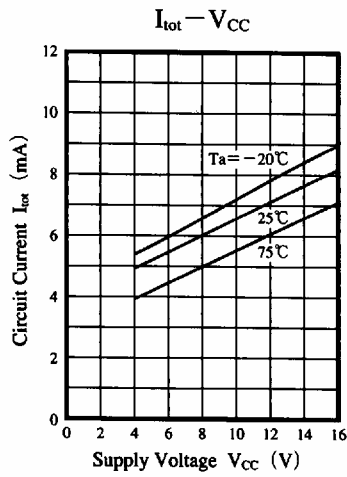
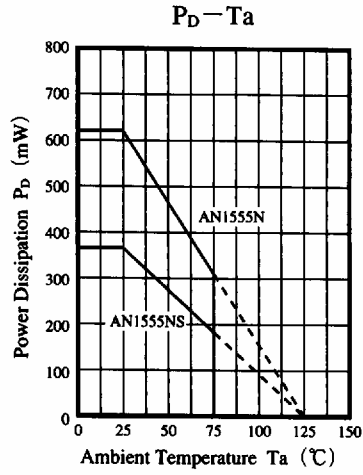

Others

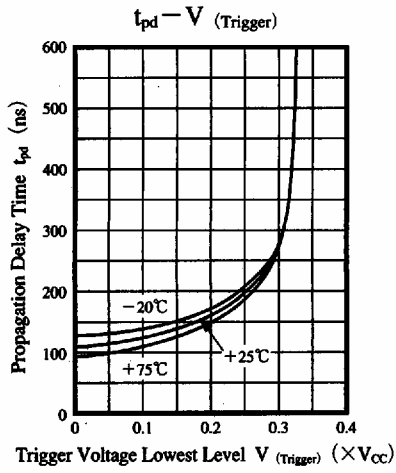

■ Application Circuit

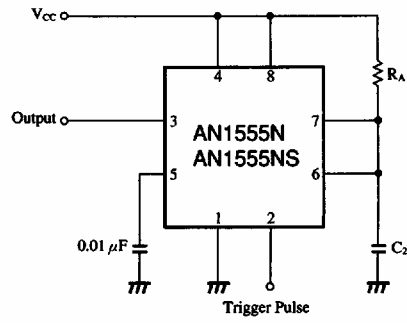

- Parts and measuring apparatus
- R<sub>A</sub> : Metal film resistor
- C<sub>2</sub> : Polyester capacitor
- Output : Universal counter load 1kΩ