

**Features**

- Universal Input Voltage 90-264 VAC, 130-370 VDC, 47-63 Hz
- Internal EMI filter
- Input connector mates with Molex housing 09-50-3051 and Molex 2478 and 2578 series crimp terminal
- Output connector mates with Molex housing 09-50-3131 and Molex 2478 and 2578 series crimp terminal
- Input Surge current, over voltage and over load protection
- Power factor correction
- Power fail detect (optional)
- Class I Insulation
- Size : 3" x 5" x 1.28"(1U)
- Two Year Warranty



Model Number	Output Voltage	Output Current	Total Regulation	Max Output Power
VSBU-120-D305	+3.3 VDC	1.5~15 A	±5%	79.5 W
	+5 VDC	0.8~6 A	±5%	79.5 W
VSBU-120-D312	+3.3 VDC	1.5~15 A	±5%	120 W
	+12 VDC	0.6~6 A	±5%	120 W
VSBU-120-D512	5 VDC	1.5~15 A	±5%	120 W
	12 VDC	0.8~6 A	±5%	120 W
VSBU-120-D515	5 VDC	1.5~15 A	±5%	120 W
	15 VDC	0.6~6 A	±5%	120 W
VSBU-120-D524A	5 VDC	1.5~15 A	±5%	120 W
	24 VDC	0.4~3.5 A	±5%	120 W
VSBU-120-D524B	5 VDC	1.5~15 A	±5%	120 W
	-24 DVC	0.2~2 A	±5%	120 W
VSBU-120-D285	28 VDC	0.4~3.92 A	±5%	120 W
	5 VDC	0~2 A	±5%	120 W

### Electrical Characteristics

Parameter	Test Conditions	Min.	Typ.	Max.	Unit
Input Voltage		90		264	VAC
		130		370	VDC
Input Frequency		47		63	Hz
Power Factor Correction	Full load at 90~260VAC	0.95	0.97	1.0	
Output Power Range	at 90 to 264 VAC	0		120	W
Input Current (low line)	Full load at 115VAC			1.7	A
Input Current (high line)	Full load at 230VAC			1.0	A
Low Line Inrush Current	Full load, 25°C, cool start, at 115VAC		12	15	A
High Line Inrush Current	Full load, 25°C, cool start, at 230VAC		26	30	A
Efficiency	Full load, at 230VAC	70	80	88	%
Line Regulation	Full load		0.5	1	%
Load Regulation	at 230VAC		3	5	%
Over Voltage Protection		112		132	%
Over Current Protection		110		150	%
Transient Response	Full load to Half load, at 100VAC			4	mS
Hold-Up Time	Full load, at 110VAC	16			mS
Start up time	Full load, at 100VAC	0.3	1	2	S
Ripple & Noise (Peak to Peak)	Full load, at 90VAC		0.2	1	%
Safety Ground Leakage Current	Full load, at 240VAC		0.4	0.75	mA
Temperature Coefficient	All output	-0.04		0.04	%/°C

### Environmental

Parameter	Test Conditions	Min.	Typ.	Max.	Unit
Operating Temperature		0		70	°C
Storage Temperature		-40		85	°C
Relative Humidity		5		95	%
Derating	Derate linearly from 100% load at 50°C to 50% load at 70°C				

### Safety Specifications

Parameter	Test Conditions	Min.	Typ.	Max.	Unit
Dielectric withstanding voltage	Primary to secondary	4242			VDC
Dielectric withstanding voltage	Primary to ground	2121			VDC
Isolation resistance	Test voltage=500VDC	50			MΩ
EMI requirements for CISPR-22	at 220VAC	B			Class
EMI requirements for FCC part-15	at 110 VAC	B			Class

V-Infinity reserves the right to make changes to its products or to discontinue any product or service without notice, and to advise customers to verify the most up-to-date product information before placing orders. V-Infinity assumes no liability or responsibility for customer's applications using V-Infinity products other than repair or replacing (at V-I's option) V-Infinity products not meeting V-I's published specifications. Nothing will be covered outside of standard product warranty.

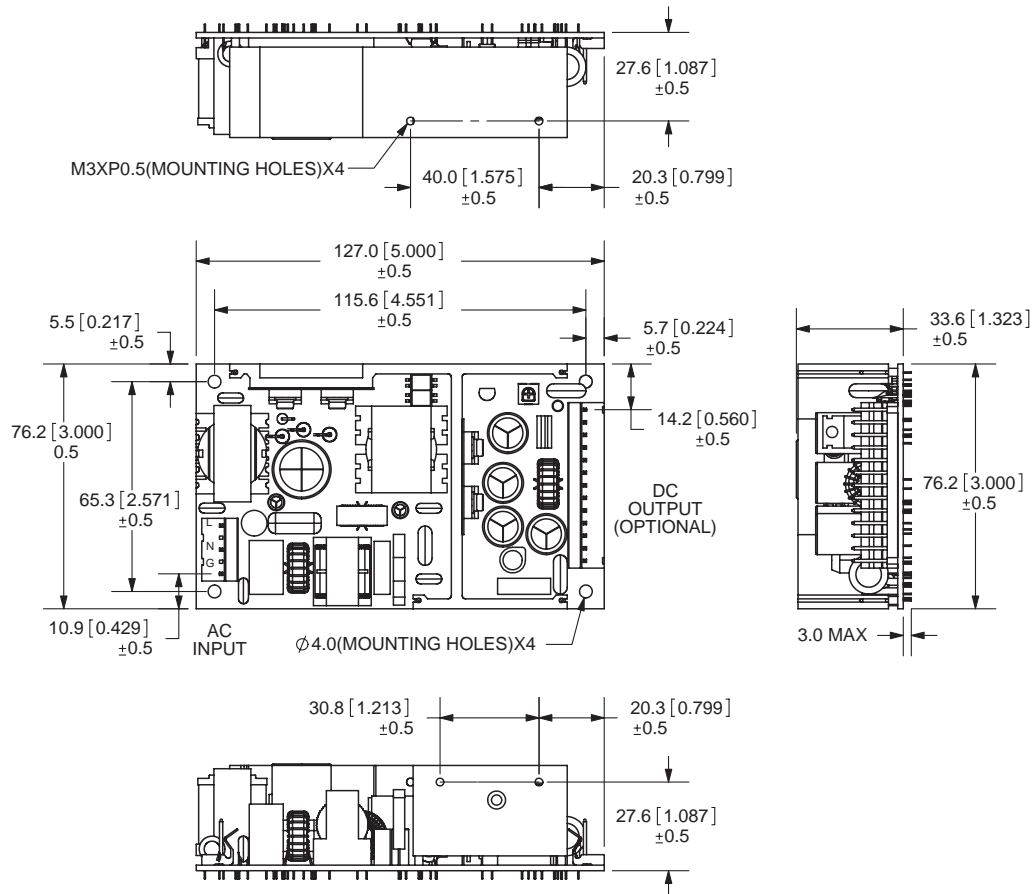
**Mechanical Specifications**

**Note:**

1. Dimensions are shown in mm (inches).
2. Weight: 330~380 g (approx.)
3. Input connector mates with Molex housing 09-50-3051 and Molex 2478 or 2578 series crimp terminal.
4. Output connector mates with Molex housing 09-05-3131 and Molex 2478 or 2578 series crimp terminal.

Model \ Pin	1	2	3	4	5	6	7	8	9	10	11	12	13 (optional)
VSBU-120-DXXX	Vo1	Vo1	Vo2	Vo2	Vo2	Vo2	COM	COM	COM	N/C	COM	COM	PFD
VSBU-120-D285	N/C	N/C	Vo1	Vo1	Vo1	Vo1	COM	COM	COM	Vo3	COM	COM	PFD
VSBU-120-D524A	N/C	N/C	Vo1	Vo1	Vo1	Vo1	COM	COM	COM	Vo3	COM	COM	PFD