

# DATA SHEET

## **TN26/15/11** **Gapped ferrite toroids**

Supersedes data of September 2004

2008 Sep 01

# Gapped ferrite toroids

TN26/15/11

## RING CORES (TOROIDS)

### Effective core parameters

SYMBOL	PARAMETER	VALUE	UNIT
$\Sigma(I/A)$	core factor (C1)	0.982	mm <sup>-1</sup>
$V_e$	effective volume	3700	mm <sup>3</sup>
$l_e$	effective length	60.1	mm
$A_e$	effective area	61.5	mm <sup>2</sup>
m	mass of core	≈ 19	g

### Coating

The cores are coated with polyamide 11 (PA11), flame retardant in accordance with "UL 94V-2"; UL file number E 45228 (M).

The colour is white.

Maximum operating temperature is 160 °C.

### Isolation voltage

DC isolation voltage: 2000 V.

Contacts are applied on the edge of the ring core, which is also the critical point for the winding operation.

### Ring core data

GRADE	$A_L^{(1)}$ (nH)	$\mu_e$	TYPE NUMBER
3C20	113 ± 15%	≈ 90	TN26/11-3C20-A113
	157 ± 15%	≈ 125	TN26/11-3C20-A157
	185 ± 15%	≈ 147	TN26/11-3C20-A185
	201 ± 15%	≈ 160	TN26/11-3C20-A201
	217 ± 15%	≈ 173	TN26/11-3C20-A217

### Note

1. Winding equally distributed over the circumference.

### Properties of cores under power conditions

GRADE	B (mT) at	CORE LOSS (W) at	
	H = 1200 A/m; f = 10 kHz; T = 100 °C	f = 100 kHz; B = 100 mT; T = 100 °C	f = 100 kHz; B = 200 mT; T = 100 °C
3C20	~ 400	≤ 0.33	≤ 2.2

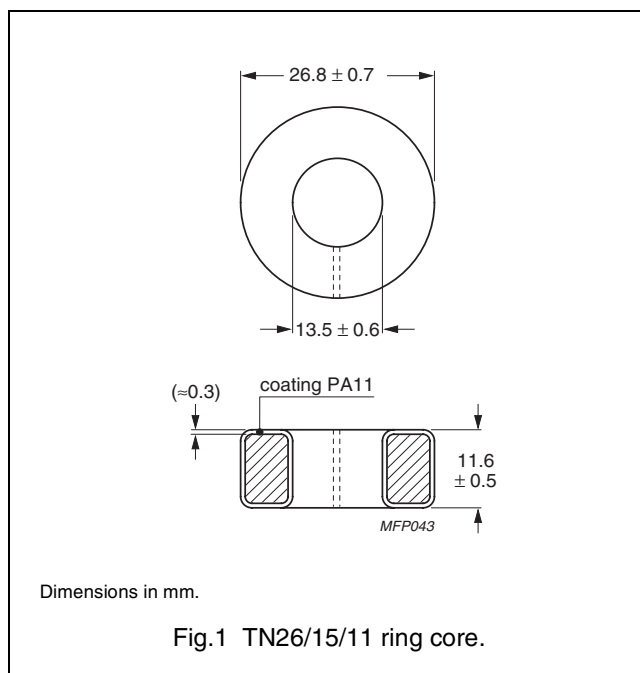

## Gapped ferrite toroids

TN26/15/11

## DATA SHEET STATUS DEFINITIONS

DATA SHEET STATUS	PRODUCT STATUS	DEFINITIONS
Preliminary specification	Development	This data sheet contains preliminary data. Ferroxcube reserves the right to make changes at any time without notice in order to improve design and supply the best possible product.
Product specification	Production	This data sheet contains final specifications. Ferroxcube reserves the right to make changes at any time without notice in order to improve design and supply the best possible product.

## DISCLAIMER

**Life support applications** — These products are not designed for use in life support appliances, devices, or systems where malfunction of these products can reasonably be expected to result in personal injury. Ferroxcube customers using or selling these products for use in such applications do so at their own risk and agree to fully indemnify Ferroxcube for any damages resulting from such application.

## PRODUCT STATUS DEFINITIONS

STATUS	INDICATION	DEFINITION
<b>Prototype</b>		These are products that have been made as development samples for the purposes of technical evaluation only. The data for these types is provisional and is subject to change.
<b>Design-in</b>		These products are recommended for new designs.
<b>Preferred</b>		These products are recommended for use in current designs and are available via our sales channels.
<b>Support</b>		These products are <b>not</b> recommended for new designs and may not be available through all of our sales channels. Customers are advised to check for availability.