



GENERAL DESCRIPTION



The ICS8737I-11 is a low skew, high performance Differential-to-3.3V LVPECL Clock Generator/Divider and a member of the HiPerClockS™ family of High Performance Clock Solutions from ICS. The ICS8737I-11 has two selectable clock inputs. The CLK, nCLK pair can accept most standard differential input levels. The PCLK, nPCLK pair can accept LVPECL, CML, or SSTL input levels. The clock enable is internally synchronized to eliminate runt pulses on the outputs during asynchronous assertion/deassertion of the clock enable pin.

Guaranteed output and part-to-part skew characteristics make the ICS8737I-11 ideal for clock distribution applications demanding well defined performance and repeatability.

FEATURES

- 2 divide by 1 differential 3.3V LVPECL outputs;
2 divide by 2 differential 3.3V LVPECL outputs
- Selectable differential CLK, nCLK or LVPECL clock inputs
- CLK, nCLK pair can accept the following differential input levels: LVDS, LVPECL, LVHSTL, SSTL, HCSL
- PCLK, nPCLK supports the following input types: LVPECL, CML, SSTL
- Maximum output frequency: 650MHz
- Translates any single ended input signal (LVCMOS, LVTTTL, GTL) to LVPECL levels with resistor bias on nCLK input
- Output skew: 75ps (maximum)
- Part-to-part skew: 300ps (maximum)
- Bank skew: Bank A - 30ps (maximum)
Bank B - 45ps (maximum)
- 3.3V operating supply
- -40°C to 85°C ambient operating temperature

BLOCK DIAGRAM

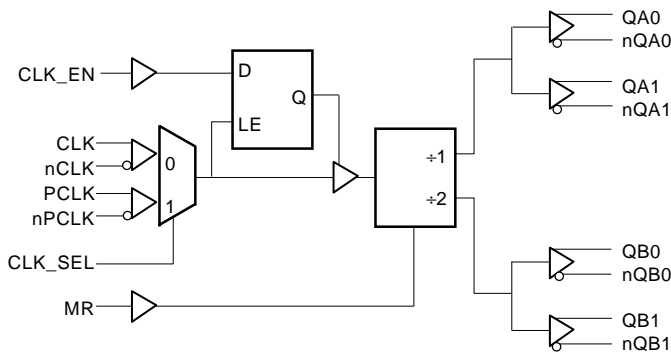

PIN ASSIGNMENT

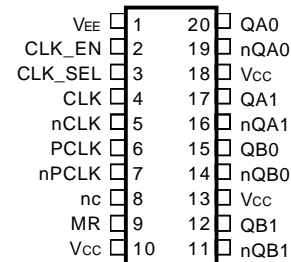

ICS8737I-11

20-Lead TSSOP

6.50mm x 4.40mm x 0.92 package body

G Package

Top View



TABLE 1. PIN DESCRIPTIONS

Number	Name	Type		Description
1	V _{EE}	Power		Negative supply pin.
2	CLK_EN	Power	Pullup	Synchronizing clock enable. When HIGH, clock outputs follow clock input. When LOW, Q outputs are forced low, nQ outputs are forced high. LVTTTL / LVCMOS interface levels.
3	CLK_SEL	Input	Pulldown	Clock Select input. When HIGH, selects PCLK, nPCLK inputs. When LOW, selects CLK, nCLK inputs. LVTTTL / LVCMOS interface levels.
4	CLK	Input	Pulldown	Non-inverting differential clock input.
5	nCLK	Input	Pullup	Inverting differential clock input.
6	PCLK	Input	Pulldown	Non-inverting differential LVPECL clock input.
7	nPCLK	Input	Pullup	Inverting differential LVPECL clock input.
8	nc	Unused		No connect.
9	MR	Input	Pulldown	Master reset. Resets the output divider. LVCMOS / LVTTTL interface levels.
10, 13, 18	V _{CC}	Power		Positive supply pins.
11, 12	nQB1, QB1	Output		Differential output pair. LVPECL interface levels.
14, 15	nQB0, QB0	Output		Differential output pair. LVPECL interface levels.
16, 17	nQA1, QA1	Output		Differential output pair. LVPECL interface levels.
19, 20	nQA0, QA0	Output		Differential output pair. LVPECL interface levels.

NOTE: *Pullup* and *Pulldown* refer to internal input resistors. See Table 2, Pin Characteristics, for typical values.

TABLE 2. PIN CHARACTERISTICS

Symbol	Parameter	Test Conditions	Minimum	Typical	Maximum	Units
C _{IN}	Input Capacitance				4	pF
R _{PULLUP}	Input Pullup Resistor			51		KΩ
R _{PULLDOWN}	Input Pulldown Resistor			51		KΩ



TABLE 3A. CONTROL INPUT FUNCTION TABLE

Inputs				Outputs			
MR	CLK_EN	CLK_SEL	Selected Source	QA0, QA1	nQA0, nQA1	QB0, QB1	nQB0, nQB1
1	X	X	X	LOW	HIGH	LOW	HIGH
0	0	0	CLK, nCLK	Disabled; LOW	Disabled; HIGH	Disabled; LOW	Disabled; HIGH
0	0	1	PCLK, nPCLK	Disabled; LOW	Disabled; HIGH	Disabled; LOW	Disabled; HIGH
0	1	0	CLK, nCLK	Enabled	Enabled	Enabled	Enabled
0	1	1	PCLK, nPCLK	Enabled	Enabled	Enabled	Enabled

After CLK_EN switches, the clock outputs are disabled or enabled following a rising and falling input clock edge as shown in Figure 1.

In the active mode, the state of the outputs are a function of the CLK, nCLK and PCLK, nPCLK inputs as described in Table 3B.

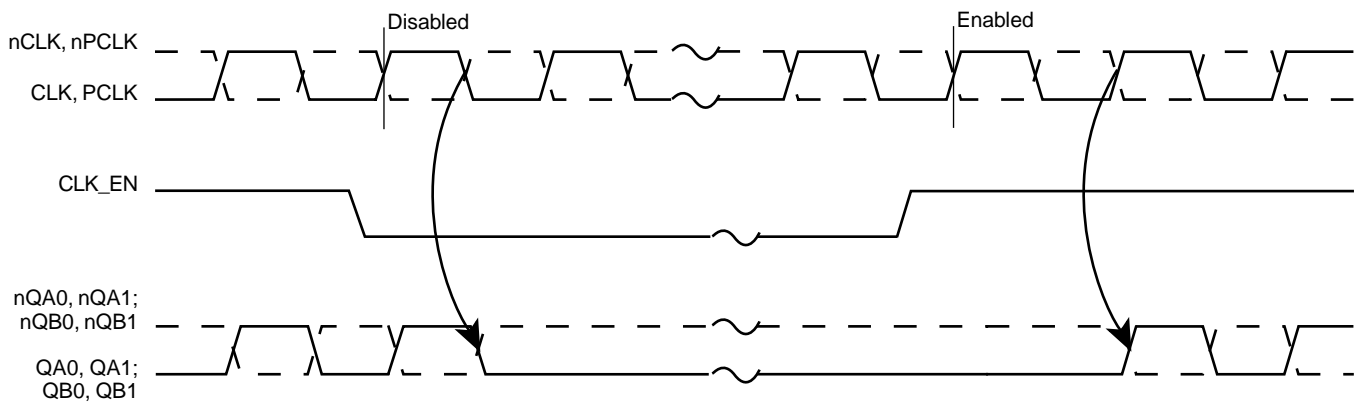

FIGURE 1 - CLK_EN TIMING DIAGRAM

TABLE 3B. CLOCK INPUT FUNCTION TABLE

Inputs		Outputs				Input to Output Mode	Polarity
CLK or PCLK	nCLK or nPCLK	QAx	nQAx	QBx	nQBx		
0	0	LOW	HIGH	LOW	HIGH	Differential to Differential	Non Inverting
1	1	HIGH	LOW	HIGH	LOW	Differential to Differential	Non Inverting
0	Biased; NOTE 1	LOW	HIGH	LOW	HIGH	Single Ended to Differential	Non Inverting
1	Biased; NOTE 1	HIGH	LOW	HIGH	LOW	Single Ended to Differential	Non Inverting
Biased; NOTE 1	0	HIGH	LOW	HIGH	LOW	Single Ended to Differential	Inverting
Biased; NOTE 1	1	LOW	HIGH	LOW	HIGH	Single Ended to Differential	Inverting

NOTE 1: Please refer to the Application Information section, "Wiring the Differential Input to Accept Single Ended Levels".



DIFFERENTIAL-TO- 3.3V LVPECL CLOCK GENERATOR

ABSOLUTE MAXIMUM RATINGS

Supply Voltage, V_{CC}	4.6V
Inputs, V_I	-0.5V to $V_{CC} + 0.5V$
Outputs, V_O	-0.5V to $V_{CC} + 0.5V$
Package Thermal Impedance, θ_{JA}	73.2°C/W (0 lfpm)
Storage Temperature, T_{STG}	-65°C to 150°C

Stresses beyond those listed under Absolute Maximum Ratings may cause permanent damage to the device. These ratings are stress specifications only. Functional operation of product at these conditions or any conditions beyond those listed in the *DC Characteristics* or *AC Characteristics* is not implied. Exposure to absolute maximum rating conditions for extended periods may affect product reliability.

TABLE 4A. POWER SUPPLY DC CHARACTERISTICS, $V_{CC} = 3.3V \pm 5\%$, $T_A = -40^\circ C$ TO $85^\circ C$

Symbol	Parameter	Test Conditions	Minimum	Typical	Maximum	Units
V_{CC}	Positive Supply Voltage		3.135	3.3	3.465	V
I_{EE}	Power Supply Current				55	mA

TABLE 4B. LVCMOS / LVTTTL DC CHARACTERISTICS, $V_{CC} = 3.3V \pm 5\%$, $T_A = -40^\circ C$ TO $85^\circ C$

Symbol	Parameter	Test Conditions	Minimum	Typical	Maximum	Units
V_{IH}	CLK_EN, CLK_SEL, MR		2		$V_{CC} + 0.3$	V
V_{IL}	CLK_EN, CLK_SEL, MR		-0.3		0.8	V
I_{IH}	Input High Current	CLK_EN	$V_{IN} = V_{CC} = 3.465V$		5	μA
		CLK_SEL, MR	$V_{IN} = V_{CC} = 3.465V$		150	μA
I_{IL}	Input Low Current	CLK_EN	$V_{IN} = 0V, V_{CC} = 3.465V$	-150		μA
		CLK_SEL, MR	$V_{IN} = 0V, V_{CC} = 3.465V$	-5		μA

TABLE 4C. DIFFERENTIAL DC CHARACTERISTICS, $V_{CC} = 3.3V \pm 5\%$, $T_A = -40^\circ C$ TO $85^\circ C$

Symbol	Parameter	Test Conditions	Minimum	Typical	Maximum	Units
I_{IH}	Input High Current	nCLK	$V_{IN} = V_{CC} = 3.465V$		5	μA
		CLK	$V_{IN} = V_{CC} = 3.465V$		150	μA
I_{IL}	Input Low Current	nCLK	$V_{IN} = 0V, V_{CC} = 3.465V$	-150		μA
		CLK	$V_{IN} = 0V, V_{CC} = 3.465V$	-5		μA
V_{PP}	Peak-to-Peak Input Voltage		0.15		1.3	V
V_{CMR}	Common Mode Input Voltage; NOTE 1, 2		$V_{EE} + 0.5$		$V_{CC} - 0.85$	V

NOTE 1: For single ended applications, the maximum input voltage for CLK, nCLK is $V_{CC} + 0.3V$.

NOTE 2: Common mode voltage is defined as V_{IH} .



DIFFERENTIAL-TO- 3.3V LVPECL CLOCK GENERATOR

TABLE 4D. LVPECL DC CHARACTERISTICS, $V_{CC} = 3.3V \pm 5\%$, $T_A = -40^\circ C$ TO $85^\circ C$

Symbol	Parameter	Test Conditions	Minimum	Typical	Maximum	Units
I_{IH}	Input High Current	$V_{IN} = V_{CC} = 3.465V$			150	μA
		$V_{IN} = V_{CC} = 3.465V$			5	μA
I_{IL}	Input Low Current	$V_{IN} = 0V, V_{CC} = 3.465V$	-5			μA
		$V_{IN} = 0V, V_{CC} = 3.465V$	-150			μA
V_{PP}	Peak-to-Peak Input Voltage		0.3		1	V
V_{CMR}	Common Mode Input Voltage; NOTE 1, 2		$V_{EE} + 1.5$		V_{CC}	V
V_{OH}	Output High Voltage; NOTE 3		$V_{CC} - 1.4$		$V_{CC} - 1.0$	V
V_{OL}	Output Low Voltage; NOTE 3		$V_{CC} - 2.0$		$V_{CC} - 1.7$	V
V_{SWING}	Peak-to-Peak Output Voltage Swing		0.6		0.9	V

NOTE 1: Common mode voltage is defined as V_{IH} .

NOTE 2: For single ended applications, the maximum input voltage for PCLK, nPCLK is $V_{CC} + 0.3V$.

NOTE 3: Outputs terminated with 50Ω to $V_{CC} - 2V$.

TABLE 5. AC CHARACTERISTICS, $V_{CC} = 3.3V \pm 5\%$, $T_A = -40^\circ C$ TO $85^\circ C$

Symbol	Parameter	Test Conditions	Minimum	Typical	Maximum	Units
f_{MAX}	Output Frequency				650	MHz
t_{PD}	Propagation Delay; NOTE 1	CLK, nCLK	$f \leq 650MHz$	1.2	1.8	ns
		PCLK, nPCLK	$f \leq 650MHz$	1.1	1.7	ns
$t_{sk(o)}$	Output Skew; NOTE 2, 4				75	ps
$t_{sk(b)}$	Bank Skew; NOTE 4	Bank A			30	ps
		Bank B			45	ps
$t_{sk(pp)}$	Part-to-Part Skew; NOTE 3, 4				300	ps
t_R	Output Rise Time	20% to 80% @ 50MHz	300		700	ps
t_F	Output Fall Time	20% to 80% @ 50MHz	300		700	ps
odc	Output Duty Cycle		47	50	53	%

All parameters measured at 500MHz unless noted otherwise.

The cycle-to-cycle jitter on the input will equal the jitter on the output. The part does not add jitter.

NOTE 1: Measured from the differential input crossing point to the differential output crossing point.

NOTE 2: Defined as skew between outputs at the same supply voltage and with equal load conditions.

Measured at the output differential cross points.

NOTE 3: Defined as skew between outputs on different devices operating at the same supply voltages and with equal load conditions. Using the same type of inputs on each device, the outputs are measured at the differential cross points.

NOTE 4: This parameter is defined in accordance with JEDEC Standard 65.



PARAMETER MEASUREMENT INFORMATION

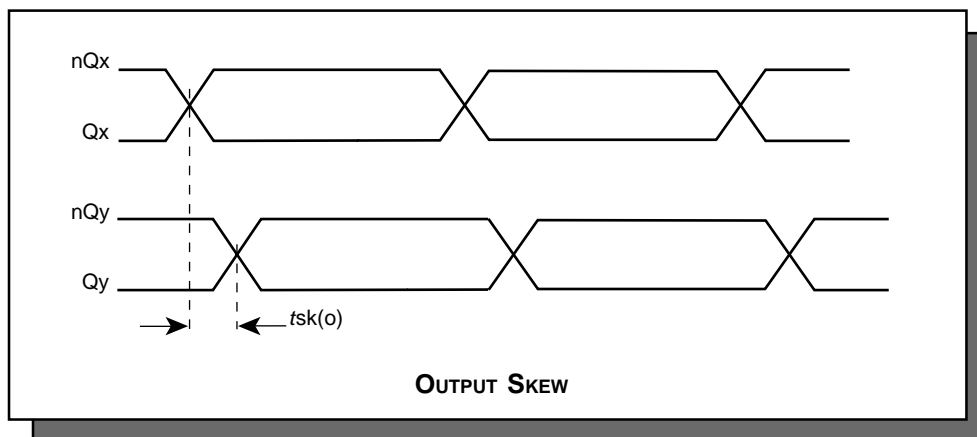
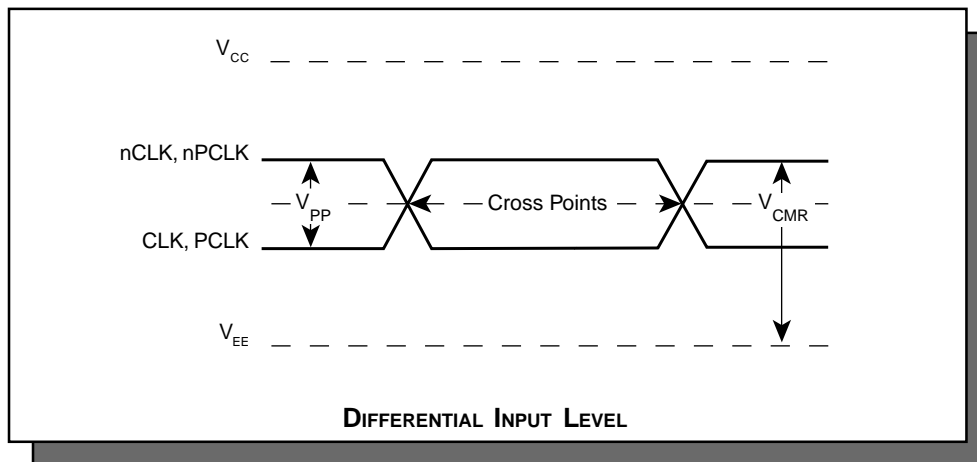
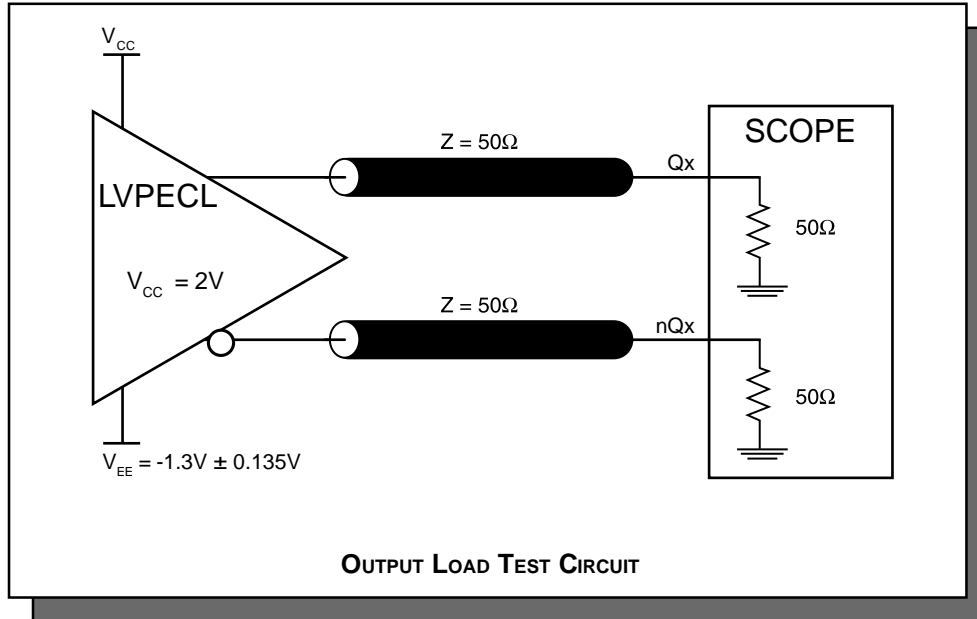



DIFFERENTIAL-TO-3.3V LVPECL CLOCK GENERATOR

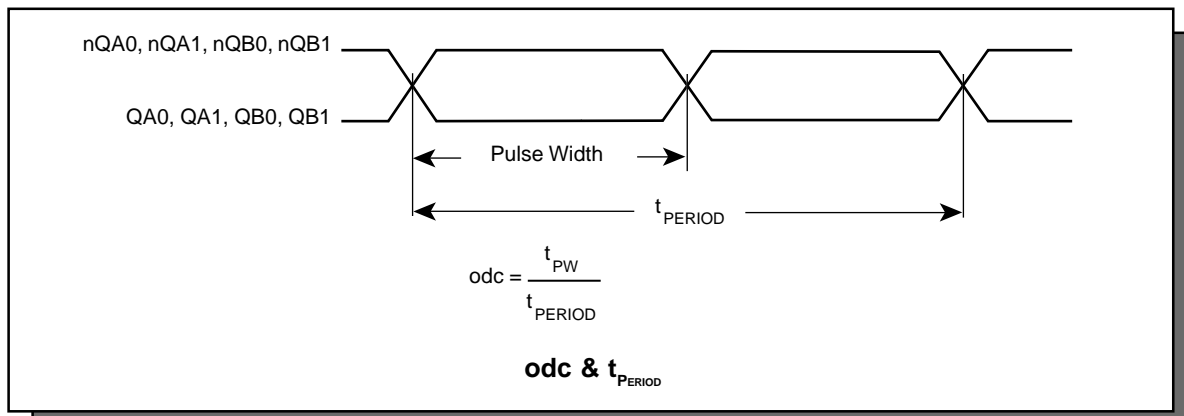
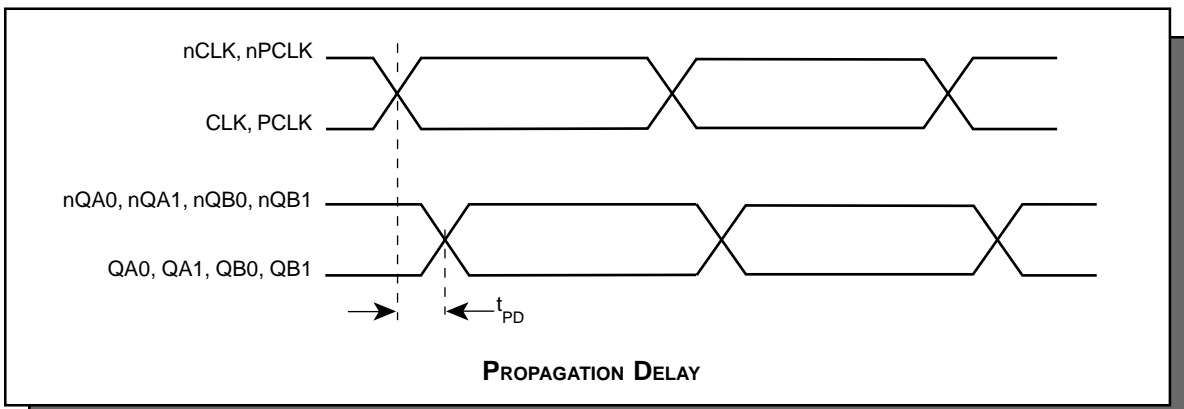
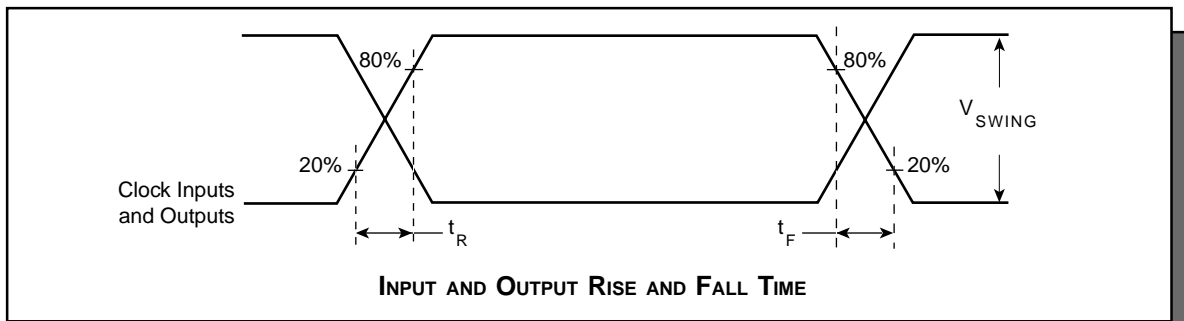
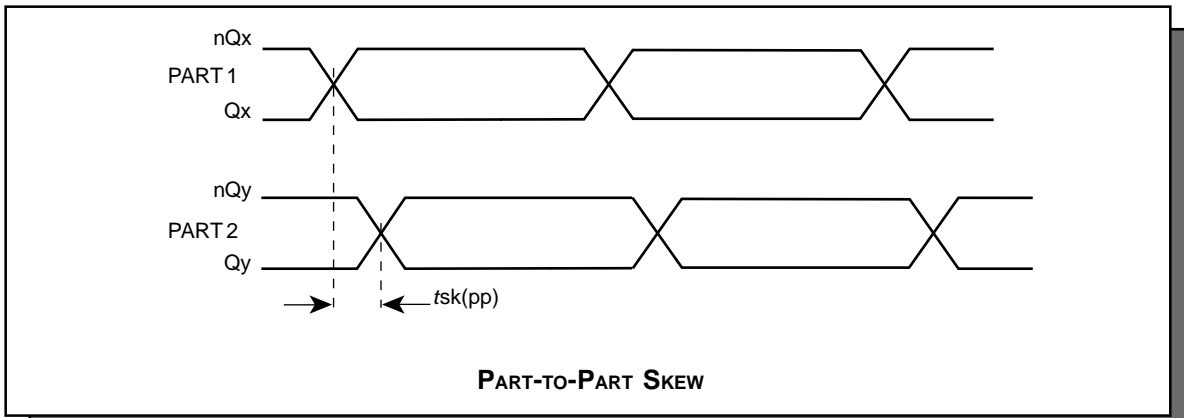



APPLICATION INFORMATION

WIRING THE DIFFERENTIAL INPUT TO ACCEPT SINGLE ENDED LEVELS

Figure 2 shows how the differential input can be wired to accept single ended levels. The reference voltage $V_{REF} \approx V_{CC}/2$ is generated by the bias resistors R1, R2 and C1. This bias circuit should be located as close as possible to the input pin. The ratio of R1 and R2 might need to be adjusted to position the V_{REF} in the center of the input voltage swing. For example, if the input clock swing is only 2.5V and $V_{CC} = 3.3V$, V_{REF} should be 1.25V and $R2/R1 = 0.609$.

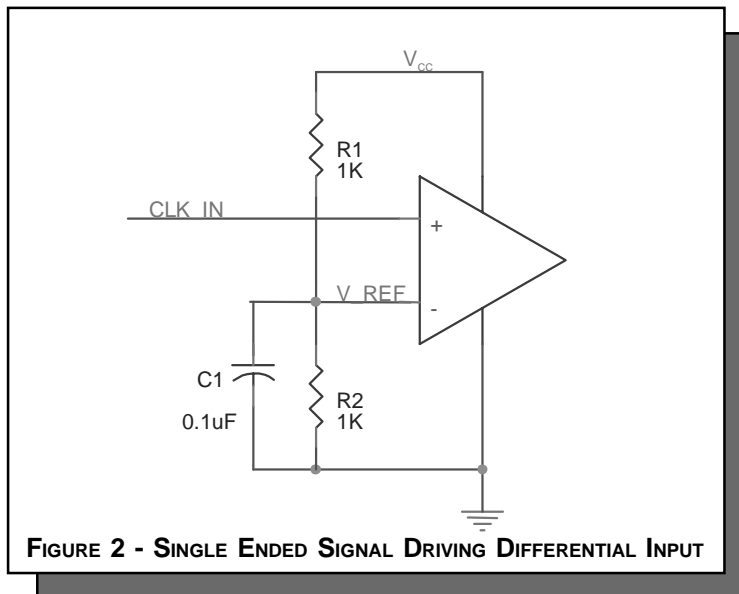

TERMINATION FOR LVPECL OUTPUTS

The clock layout topology shown below is a typical termination for LVPECL outputs. The two different layouts mentioned are recommended only as guidelines.

F_{OUT} and nF_{OUT} are low impedance follower outputs that generate ECL/LVPECL compatible outputs. Therefore, terminating resistors (DC current path to ground) or current sources must be used for functionality. These outputs are designed to drive

50Ω transmission lines. Matched impedance techniques should be used to maximize operating frequency and minimize signal distortion. Figures 3A and 3B show two different layouts which are recommended only as guidelines. Other suitable clock layouts may exist and it would be recommended that the board designers simulate to guarantee compatibility across all printed circuit and clock component process variations.

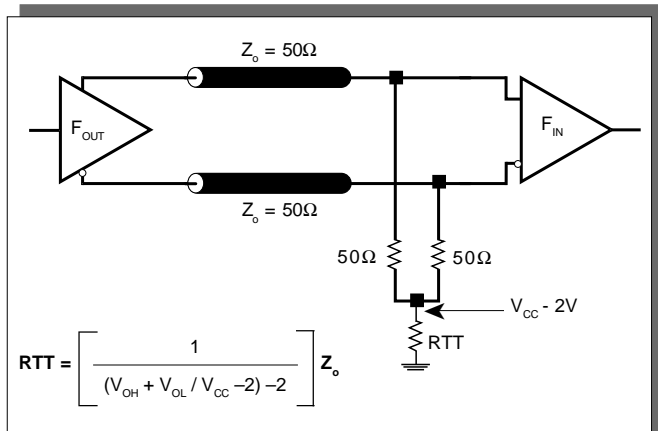

FIGURE 3A - LVPECL OUTPUT TERMINATION

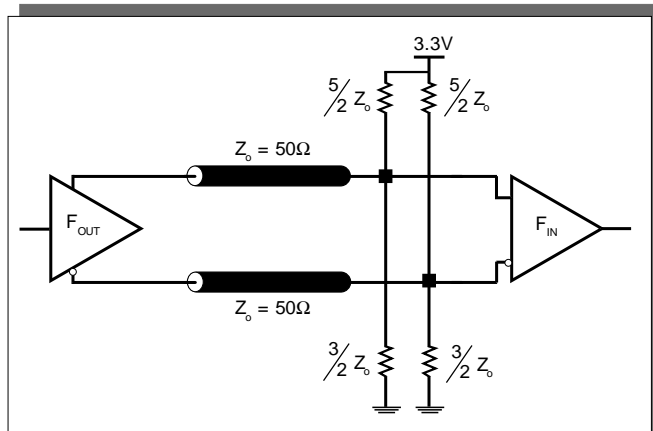

FIGURE 3B - LVPECL OUTPUT TERMINATION



POWER CONSIDERATIONS

This section provides information on power dissipation and junction temperature for the ICS8737I-11. Equations and example calculations are also provided.

1. Power Dissipation.

The total power dissipation for the ICS8737I-11 is the sum of the core power plus the power dissipated in the load(s). The following is the power dissipation for $V_{CC} = 3.3V + 5\% = 3.465V$, which gives worst case results.

NOTE: Please refer to Section 3 for details on calculating power dissipated in the load.

- Power (core)_{MAX} = $V_{CC_MAX} * I_{CC_MAX} = 3.465V * 55mA = 190.6mW$
- Power (outputs)_{MAX} = **30.2mW/Loaded Output pair**
If all outputs are loaded, the total power is $4 * 30.2mW = 120.8mW$

Total Power_{MAX} (3.465V, with all outputs switching) = $190.6mW + 120.8mW = 311.4mW$

2. Junction Temperature.

Junction temperature, T_j , is the temperature at the junction of the bond wire and bond pad and directly affects the reliability of the device. The maximum recommended junction temperature for HiPerClockS™ devices is 125°C.

The equation for T_j is as follows: $T_j = \theta_{JA} * Pd_total + T_A$

T_j = Junction Temperature

θ_{JA} = Junction-to-Ambient Thermal Resistance

Pd_total = Total Device Power Dissipation (example calculation is in section 1 above)

T_A = Ambient Temperature

In order to calculate junction temperature, the appropriate junction-to-ambient thermal resistance θ_{JA} must be used. Assuming a moderate air flow of 200 linear feet per minute and a multi-layer board, the appropriate value is 66.6°C/W per Table 6 below. Therefore, T_j for an ambient temperature of 85°C with all outputs switching is:

$85°C + 0.311W * 66.6°C/W = 105.7°C$. This is well below the limit of 125°C

This calculation is only an example. T_j will obviously vary depending on the number of loaded outputs, supply voltage, air flow, and the type of board (single layer or multi-layer).

TABLE 6. THERMAL RESISTANCE θ_{JA} FOR 20-PIN TSSOP, FORCED CONVECTION

	θ_{JA} by Velocity (Linear Feet per Minute)		
	0	200	500
Single-Layer PCB, JEDEC Standard Test Boards	114.5°C/W	98.0°C/W	88.0°C/W
Multi-Layer PCB, JEDEC Standard Test Boards	73.2°C/W	66.6°C/W	63.5°C/W

NOTE: Most modern PCB designs use multi-layered boards. The data in the second row pertains to most designs.



3. Calculations and Equations.

LVPECL output driver circuit and termination are shown in Figure 4.

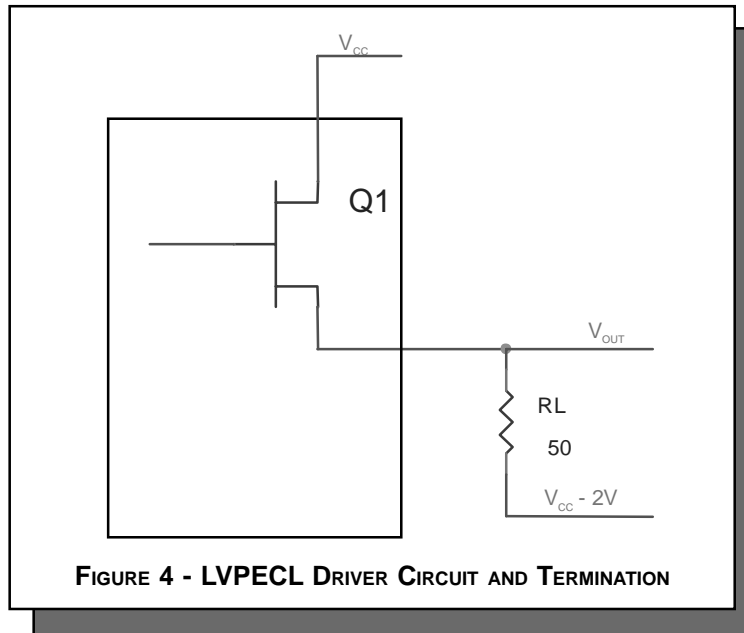

To calculate worst case power dissipation into the load, use the following equations which assume a 50Ω load, and a termination voltage of $V_{CC} - 2V$.

- For logic high, $V_{OUT} = V_{OH_MAX} = V_{CC_MAX} - 1.0V$

$$(V_{CC_MAX} - V_{OH_MAX}) = 1.0V$$

- For logic low, $V_{OUT} = V_{OL_MAX} = V_{CC_MAX} - 1.7V$

$$(V_{CC_MAX} - V_{OL_MAX}) = 1.7V$$

Pd_H is power dissipation when the output drives high.

Pd_L is the power dissipation when the output drives low.

$$Pd_H = [(V_{OH_MAX} - (V_{CC_MAX} - 2V)) / R_L] * (V_{CC_MAX} - V_{OH_MAX}) = [(2V - (V_{CC_MAX} - V_{OH_MAX})) / R_L] * (V_{CC_MAX} - V_{OH_MAX}) = [(2V - 1V) / 50\Omega] * 1V = 20.0mW$$

$$Pd_L = [(V_{OL_MAX} - (V_{CC_MAX} - 2V)) / R_L] * (V_{CC_MAX} - V_{OL_MAX}) = [(2V - (V_{CC_MAX} - V_{OL_MAX})) / R_L] * (V_{CC_MAX} - V_{OL_MAX}) = [(2V - 1.7V) / 50\Omega] * 1.7V = 10.2mW$$

Total Power Dissipation per output pair = $Pd_H + Pd_L = 30.2mW$



RELIABILITY INFORMATION

TABLE 7. θ_{JA} vs. AIR FLOW TABLE

θ_{JA} by Velocity (Linear Feet per Minute)			
	0	200	500
Single-Layer PCB, JEDEC Standard Test Boards	114.5°C/W	98.0°C/W	88.0°C/W
Multi-Layer PCB, JEDEC Standard Test Boards	73.2°C/W	66.6°C/W	63.5°C/W

NOTE: Most modern PCB designs use multi-layered boards. The data in the second row pertains to most designs.

TRANSISTOR COUNT

The transistor count for ICS8737I-11 is: 510



PACKAGE OUTLINE - G SUFFIX

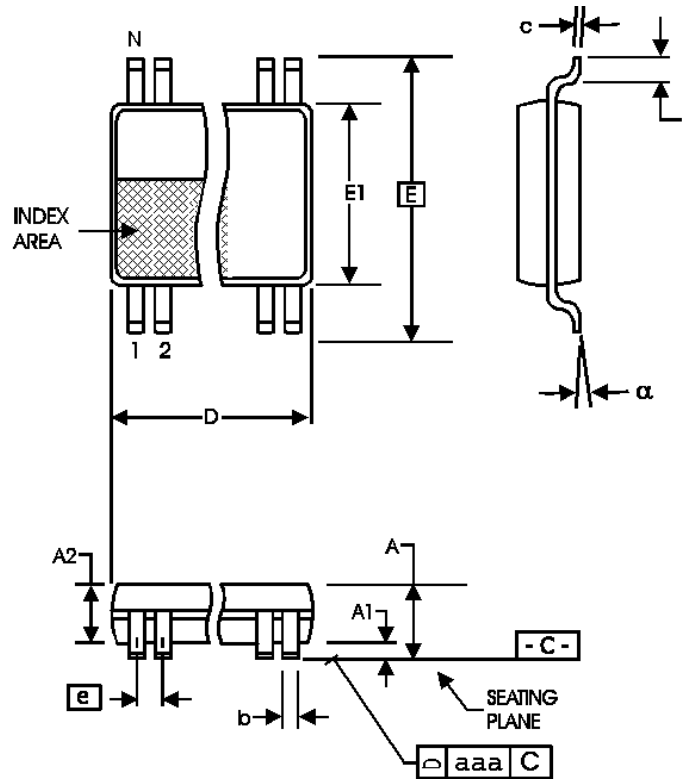

TABLE 8. PACKAGE DIMENSIONS

SYMBOL	Millimeters	
	Minimum	Maximum
N	20	
A	--	1.20
A1	0.05	0.15
A2	0.80	1.05
b	0.19	0.30
c	0.09	0.20
D	6.40	6.60
E	6.40 BASIC	
E1	4.30	4.50
e	0.65 BASIC	
L	0.45	0.75
alpha	0°	8°
aaa	--	0.10

Reference Document: JEDEC Publication 95, MO-153



Integrated
Circuit
Systems, Inc.

ICS8737I-11
LOW SKEW ±1/±2

DIFFERENTIAL-TO- 3.3V LVPECL CLOCK GENERATOR

TABLE 9. ORDERING INFORMATION

Part/Order Number	Marking	Package	Count	Temperature
ICS8737AGI-11	ICS8737AI-11	20 lead TSSOP	72	-40°C to 85°C
ICS8737AGI-11T	ICS8737AI-11	20 lead TSSOP on Tape and Reel	2500	-40°C to 85°C

While the information presented herein has been checked for both accuracy and reliability, Integrated Circuit Systems, Incorporated (ICS) assumes no responsibility for either its use or for infringement of any patents or other rights of third parties, which would result from its use. No other circuits, patents, or licenses are implied. This product is intended for use in normal commercial and industrial applications. Any other applications such as those requiring high reliability, or other extraordinary environmental requirements are not recommended without additional processing by ICS. ICS reserves the right to change any circuitry or specifications without notice. ICS does not authorize or warrant any ICS product for use in life support devices or critical medical instruments.



Integrated
Circuit
Systems, Inc.

ICS8737I-11
LOW SKEW $\pm 1/2$

DIFFERENTIAL-TO- 3.3V LVPECL CLOCK GENERATOR

REVISION HISTORY SHEET

Rev	Table	Page	Description of Change	Date
A		8	Added Termination for LVPECL Outputs section.	6/3/02