

CPTC Thermistor: Dip Type PPL Series

Overload Protection for Telecom Application



■ Features

1. RoHS compliant
2. Radial leaded devices
3. Wide resistance range in telecom area from 7 to 50Ω
4. Agency recognition: UL/cUL/TUV
5. Compliant with ITU-T standards
6. Operating temperature range : 0 ~ +60°C (V=Vmax)
-25 ~+125°C (V=0)

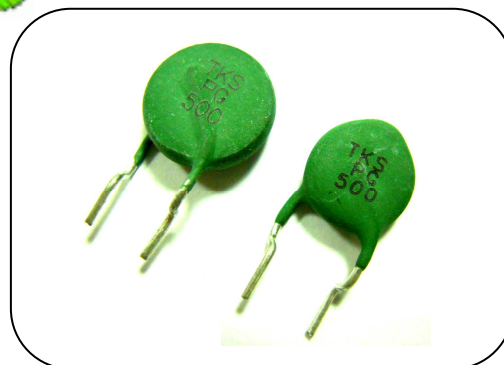

■ Recommended Applications

1. Cable Modem, ADSL Modem with VOIP
2. Customer Premise Equipment (CPE)
3. Central Office (CO)
4. Access Equipment (AE)
5. Main Distribution Frame (MDF)
6. Public Switched Telephone Network (PSTN)
7. Exchanger

■ Part Number Code

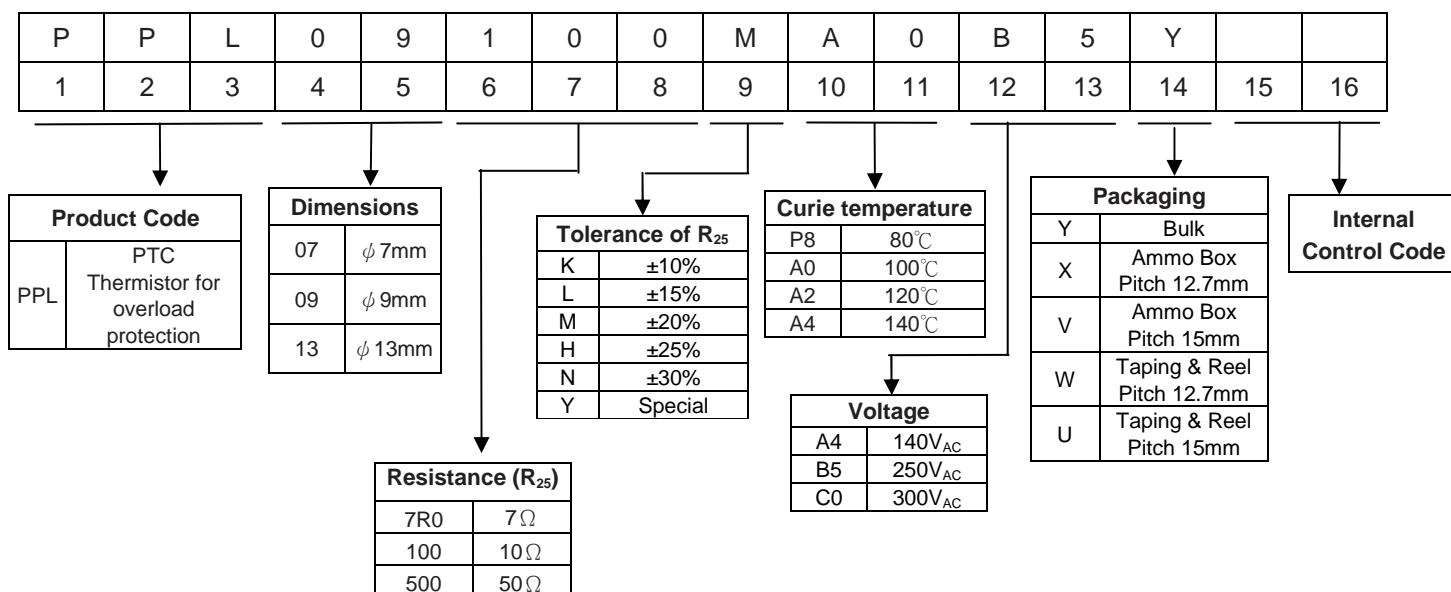

CPTC Thermistor: Dip Type PPL Series

Overload Protection for Telecom Application



■ Structure and Dimensions

● Dip structure

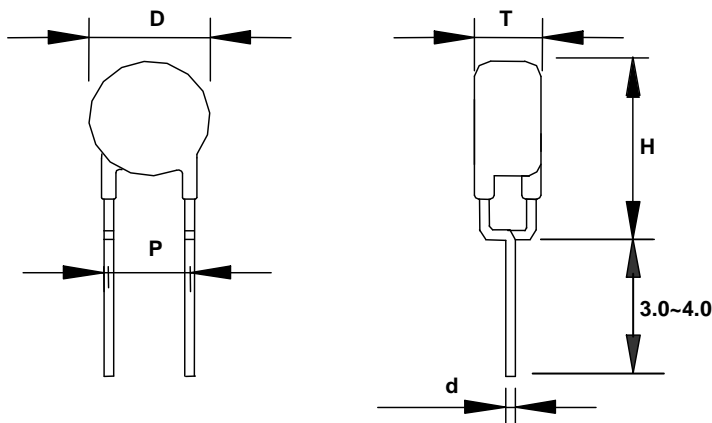

(Unit: mm)

Part no.	D	T	H	d	P
	max	max	max	±0.02	±1.0
PPL137R0□A0B5	15	5	18.5	0.6	5
PPL07100□A0B5	10.5	5	13.5	0.6	5
PPL09100□A0B5	12	5	15.5	0.6	5
PPL07180□A0B5	9	5	12.5	0.6	5
PPL09180□A0B5	11	5	14.5	0.6	5
PPL07250□A0B5	9	5	12.5	0.6	5
PPL09250□A0B5	11	5	14.5	0.6	5
PPL07390□A0B5	9	5	12.5	0.6	5
PPL09390□A0B5	11	5	14.5	0.6	5
PPL07500□A0C0	9	5	12.5	0.6	5
PPL09500□A0C0	11	5	14.5	0.6	5

CPTC Thermistor: Dip Type PPL Series

Overload Protection for Telecom Application



■ Characteristics

Part No.	Nominal Zero-power Resistance	Non-operating Current at 25°C	Non-operating Current at 40°C	Trip Current at 25°C	Responding Time (s)			Max Voltage	Max. Current	Safety Approvals	
	R ₂₅ (Ω)	I _N (mA) @25°C	I _N (mA) @40°C	I _t (mA) @25°C	3A→0.5A	1A→0.5A	0.5A→0.15A	(V _{AC})	I _{max} (A)	UL/cUL	TUV
PPL137R0□A0B5	7	180	170	540	3	20	90	250	3	√	√
PPL07100□A0B5	10	130	120	390	0.8	8.0	35	250	2.5	√	√
PPL09100□A0B5	10	140	130	390	0.8	8.0	35	250	3	√	√
PPL07180□A0B5	18	110	100	330	0.4	2.5	10	250	3	√	√
PPL09180□A0B5	18	110	100	330	0.4	2.5	10	250	3	√	√
PPL07250□A0B5	25	90	80	225	0.35	2.0	10	250	3	√	√
PPL09250□A0B5	25	75	70	225	0.35	2.0	10	250	3	√	√
PPL07390□A0B5	39	70	65	180	0.3	1.0	4.0	250	3	√	√
PPL09390□A0B5	39	70	65	180	0.3	1.0	4.0	250	3	√	√
PPL07500□A0C0	50	60	55	165	0.15	0.8	3.5	300	3	√	√
PPL09500□A0C0	50	65	60	165	0.15	0.8	3.5	300	3	√	√

Note1: □=Tolerance of R₂₅

Note2: UL/cUL File No. E138827

TUV File No. R 50171789

CPTC Thermistor: Dip Type PPL Series Overload Protection for Telecom Application



■ R-T Characteristic Curves (Typical)

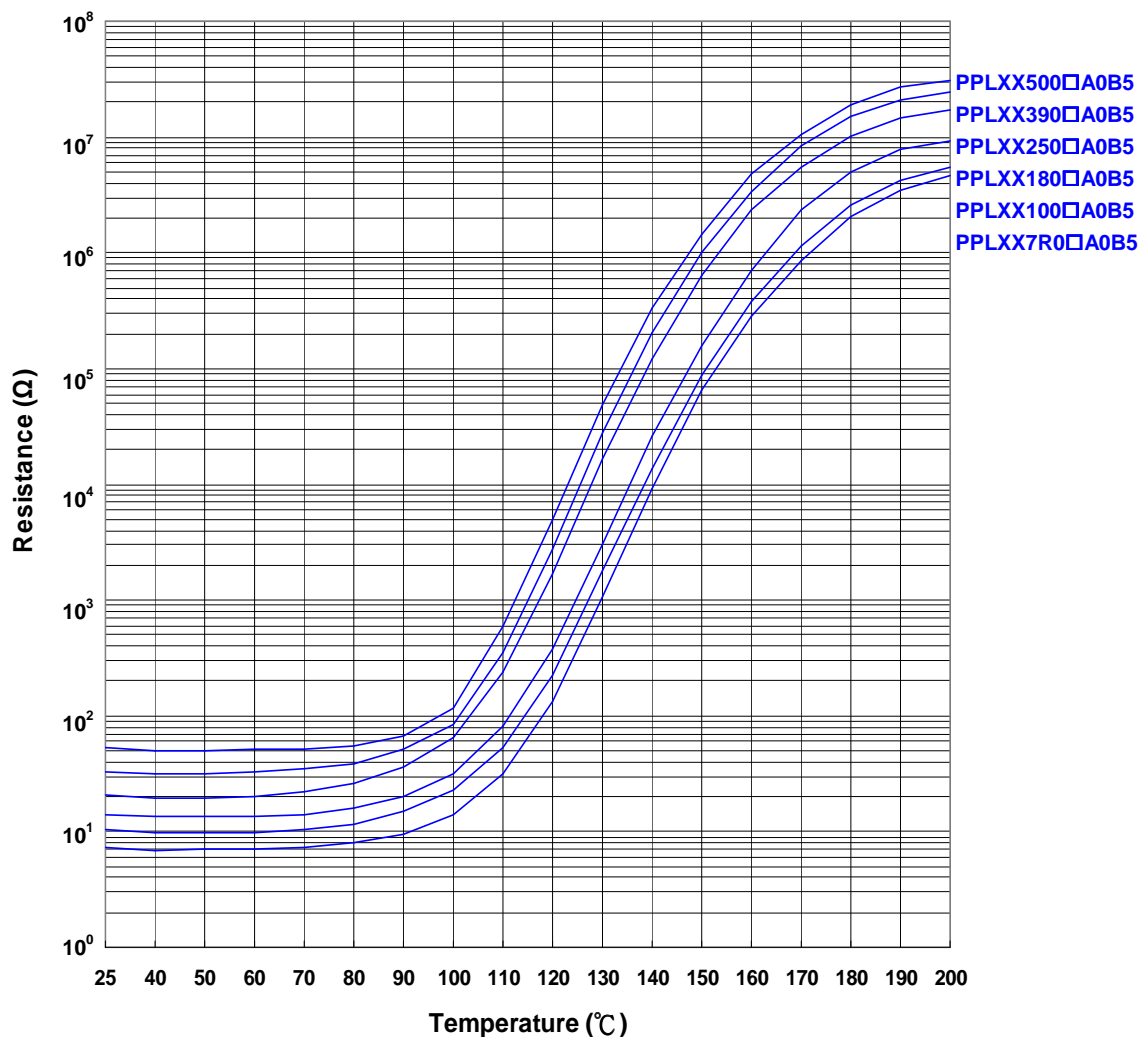

■ Circuit for Typical Application

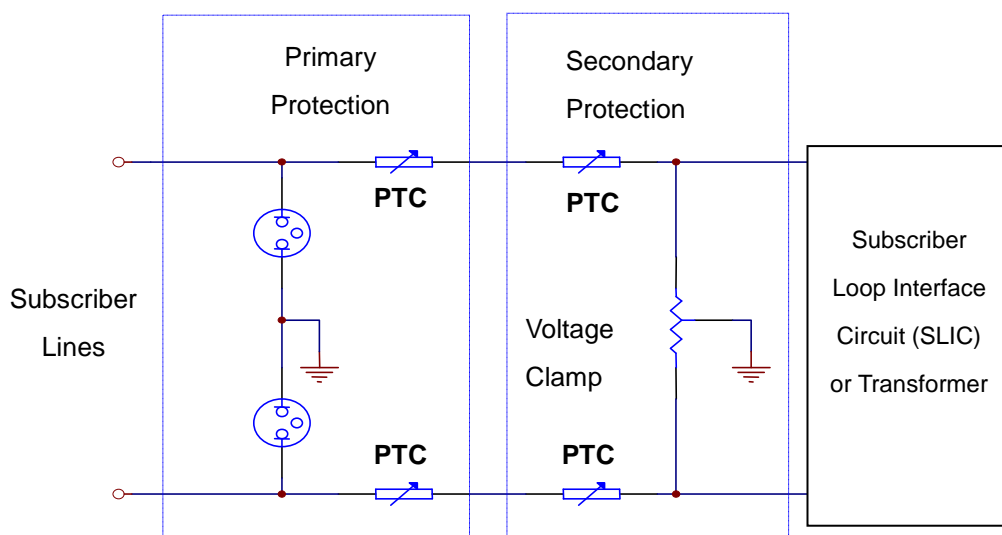

CPTC Thermistor: Dip Type PPL Series

Overload Protection for Telecom Application



■ Soldering Recommendation

- Wave Soldering Profile

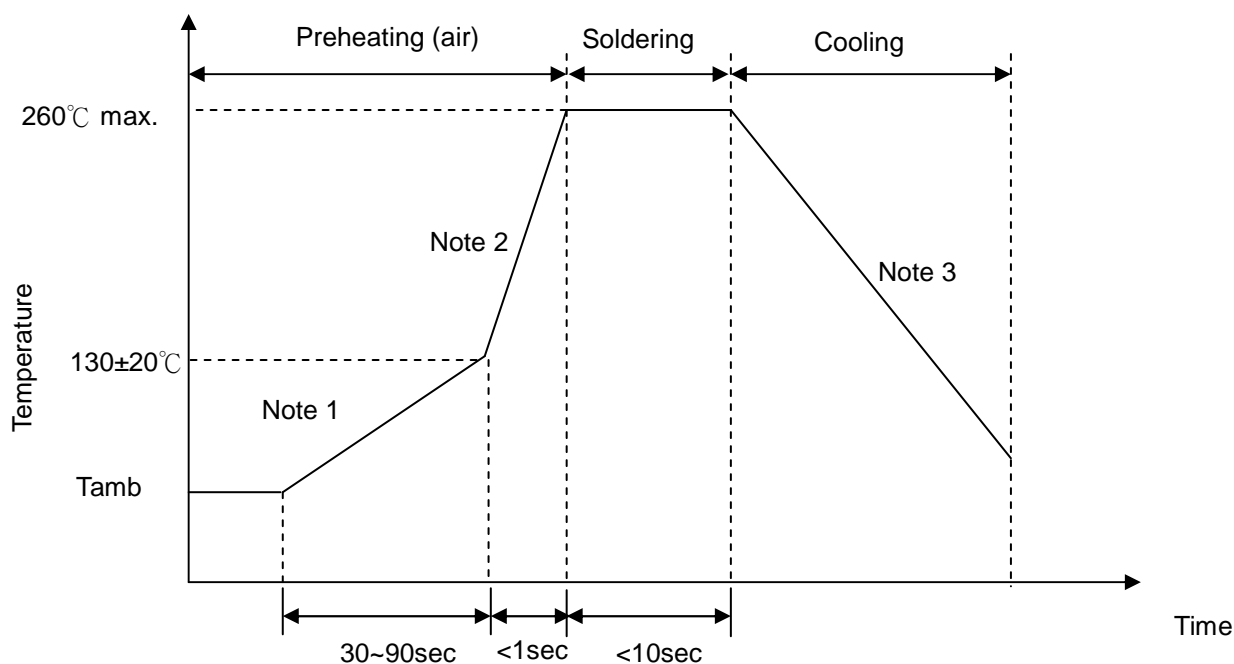

Note 1: (1~3)°C/sec

Note 2: Approx. 200°C/sec

Note 3: 5°C/sec Max

- Recommended Reworking Conditions with Soldering Iron

Item	Conditions
Temperature of Soldering Iron-tip	360°C (max.)
Soldering Time	3 sec (max.)
Distance from coating	2 mm (min.)

CPTC Thermistor: Dip Type PPL Series

Overload Protection for Telecom Application



■ Reliability

Item	Standard	Test conditions / Methods	Specifications															
Tensile Strength of Terminals	IEC60068-2-21	After gradually applying the force specified and keeping the unit fixed for 10±1 sec., the two terminals shall be visually examined for any damage. <table border="1" style="margin-left: auto; margin-right: auto;"> <thead> <tr> <th>Terminal diameter (mm)</th> <th>Force T(N)</th> </tr> </thead> <tbody> <tr> <td>0.35<d≤0.5</td> <td>5.0</td> </tr> <tr> <td>0.5<d≤0.8</td> <td>10.0</td> </tr> <tr> <td>0.8<d≤1.25</td> <td>20.0</td> </tr> </tbody> </table>	Terminal diameter (mm)	Force T(N)	0.35<d≤0.5	5.0	0.5<d≤0.8	10.0	0.8<d≤1.25	20.0	ΔR/R ₂₅ ≤ 20% No visible damage							
Terminal diameter (mm)	Force T(N)																	
0.35<d≤0.5	5.0																	
0.5<d≤0.8	10.0																	
0.8<d≤1.25	20.0																	
Solderability	IEC60068-2-20	245±3℃, 3±0.3sec, 4±1mm from body.	At least 95% of terminal electrode is covered by new solder															
Resistance to Soldering Heat	IEC60068-2-20	260±3℃, 10±1 sec, 4±1mm from body	ΔR/R ₂₅ ≤ 20% No visible damage															
Vibration	IEC60068-2-6	Frequency range:10~55Hz Amplitude:0.75mm or 98m/S2 Direction:3 mutually perpendicular directions, 2hrs each.	ΔR/R ₂₅ ≤ 20% No visible damage															
Shock	IEC60068-2-27	Wave: half-sine ΔV:1.0m/s Acceleration:50m/s2 Pulse time:30ms	ΔR/R ₂₅ ≤ 20% No visible damage															
Rapid Change of Temperature	IEC60068-2-14	The rapid change conditions shown below shall be repeated 5 cycles. <table border="1" style="margin-left: auto; margin-right: auto;"> <thead> <tr> <th>Step</th> <th>Temperature(℃)</th> <th>Period(minutes)</th> </tr> </thead> <tbody> <tr> <td>1</td> <td>-40 ± 3</td> <td>30 ± 3</td> </tr> <tr> <td>2</td> <td>Room temperature</td> <td>5 ± 3</td> </tr> <tr> <td>3</td> <td>85 ± 2</td> <td>30 ± 3</td> </tr> <tr> <td>4</td> <td>Room temperature</td> <td>5 ± 3</td> </tr> </tbody> </table>	Step	Temperature(℃)	Period(minutes)	1	-40 ± 3	30 ± 3	2	Room temperature	5 ± 3	3	85 ± 2	30 ± 3	4	Room temperature	5 ± 3	ΔR/R ₂₅ ≤ 20% No visible damage
Step	Temperature(℃)	Period(minutes)																
1	-40 ± 3	30 ± 3																
2	Room temperature	5 ± 3																
3	85 ± 2	30 ± 3																
4	Room temperature	5 ± 3																
Climatic sequence	IEC60738-1	+40℃, 20%R.H X 24hrs → 100℃ X 16hrs → 25℃ X 2hrs → +40℃, 95%R.H X 24hrs → 0℃ X 2hrs → +40℃, 95%R.H X 24hrs → 25℃ X (1~2)hrs	ΔR/R ₂₅ ≤ 20% No visible damage															
High Temperature Storage	IEC60068-2-2	60℃, for 1000 hrs	ΔR/R ₂₅ ≤ 20% No visible damage															
High Temperature Continuous Load	IEC60738-1	60℃, Vmax, It<l<lmax for 1000 hrs	ΔR/R ₂₅ ≤ 20% No visible damage															
Damp Heat, Steady State	IEC60068-2-3	40±2℃, 90~95%RH, for 1000±2 hrs	ΔR/R ₂₅ ≤ 20% No visible damage															
Over Current	Specification Standard	220Vrms, 3A, 60s on and 600s off, x20 cycles	ΔR/R ₂₅ ≤ 20% No visible damage															
Power Contact	ITU-T K.20 9.4	230Vrms, 10Ω, 15Min	ΔR/R ₂₅ ≤ 20% No visible damage															
Lightning Surge	ITU-T K30 4.2.5	DC:1.0KV, 10/1000μs, 25A, x30 cycles DC:1.5KV, 10/310μs, 37.5A, x10cycles	ΔR/R ₂₅ ≤ 20% No visible damage															
Power Induction	Specification Standard	650Vrms, 600Ω, 1s on and 60s off x10 cycles	ΔR/R ₂₅ ≤ 20% No visible damage															

CPTC Thermistor: Dip Type PPL Series Overload Protection for Telecom Application



■ Packaging

Lead Space 7.5mm (P0=12.7mm)

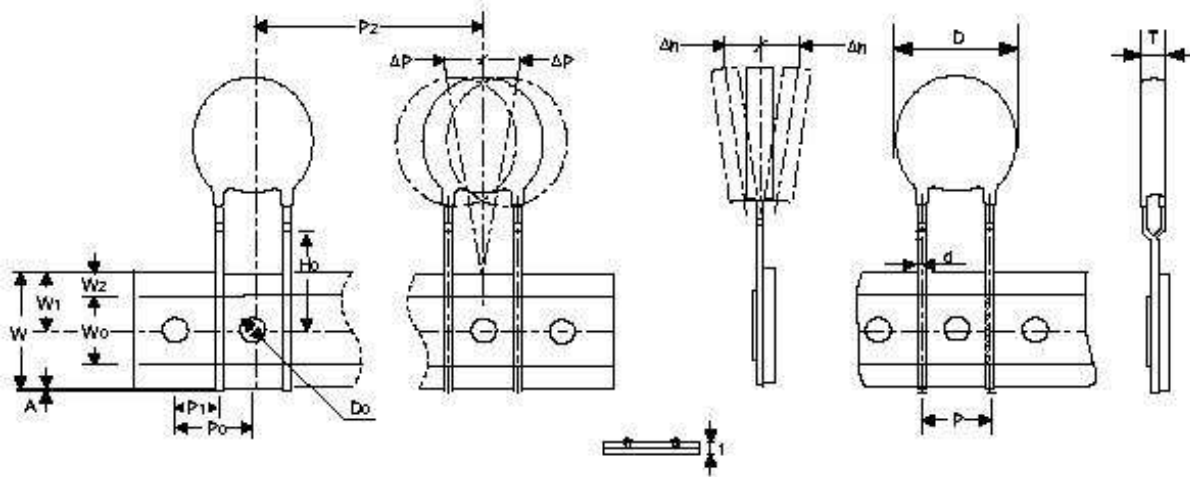

Lead Space 5.0mm & 7.5mm (P0=15mm)

Lead Space 5.0mm (P0=12.7mm)

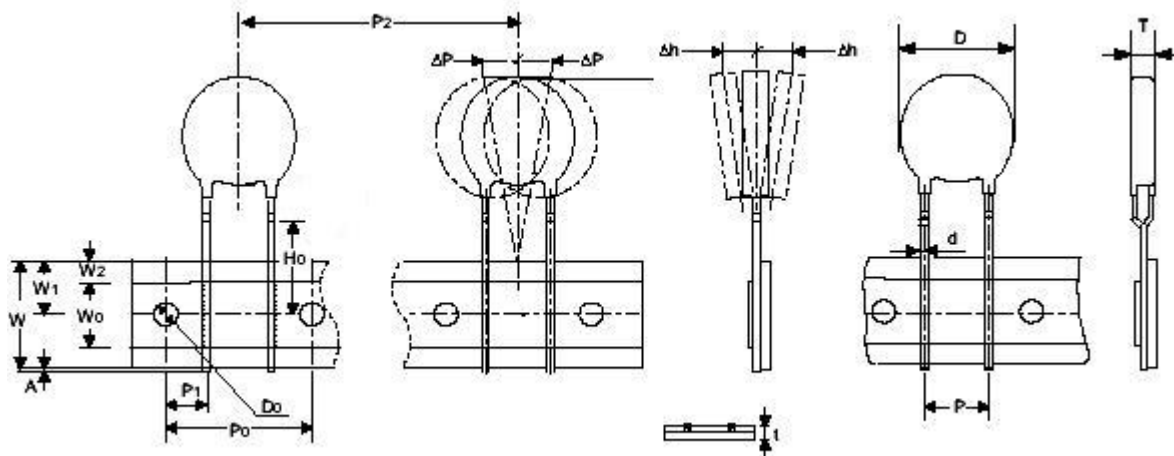

CPTC Thermistor: Dip Type PPL Series

Overload Protection for Telecom Application



(Unit: mm)

Index	Parameter	Nominal dimensions				Tolerance
P	Lead spacing	5	7.5	5	7.5	±1
P0	Sprocket hole pitch	12.7	12.7	15	15	±0.3
P1	Lead location	3.85	8.95	5	3.75	±1
P2	Component pitch	12.7 (D ≤ 10)		15.0 (D ≤ 10)		±1
		25.4 (D > 10)		30.0 (D > 10)		
H0	Height between component and tape centre	16	16	16	16	+0.5
W	Carrier tape width	18	18	18	18	±1
W0	Adhesive tape width	12	12	12	12	±1
W1	Sprocket hole position	9	9	9	9	±1
W2(max)	Adhesive tape position	3	3	3	3	Max. 3
△P	Component alignment	1	1	1	1	Max. 1
△h	Component alignment	2	2	2	2	Max. 2
A	Tip length	0.5	0.5	0.5	0.5	Max. 0.5
D0	Sprocket hole diameter	4	4	4	4	±0.2
t	Total tape thickness	0.6	0.6	0.6	0.6	±0.2

■ Quantity

● Bulk Packing

Type	Quantity (Pcs/bag)
$\Phi \leq 10$	200
$10 < \Phi < 20$	100

● Reel Packing

Type	Quantity (Pcs/Reel)
$07 < \Phi \leq 12$	1000
$12 < \Phi \leq 16$	750

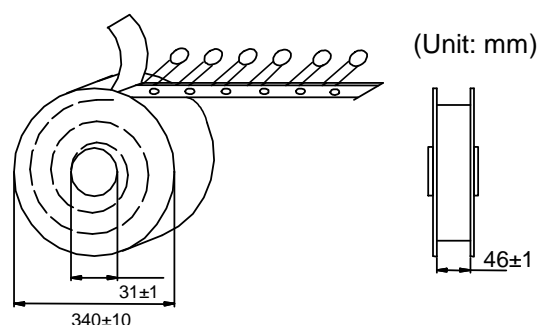

CPTC Thermistor: Dip Type PPL Series Overload Protection for Telecom Application



● Ammo Packing

Type	Quantity(pcs/Box)
07< Φ ≤ 12	750
12< Φ ≤ 16	500

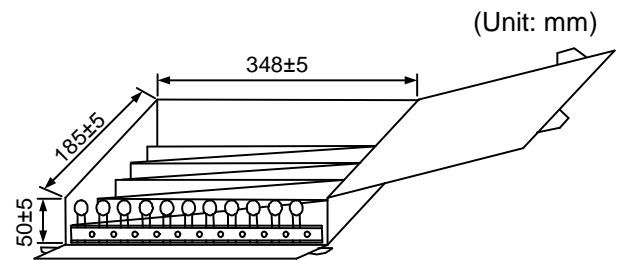

■ Storage condition of products

- Storage Conditions :
 1. Storage Temperature : -10°C ~ +40°C
 2. Relative Humidity : ≤ 75%RH
 3. Keep away from corrosive atmosphere and sunlight.
- Period of Storage : 1 year