

# MBF300

## Solid State Fingerprint Sweep Sensor™

### Overview

The Fujitsu MBF300 Solid-State Fingerprint Sweep Sensor is a direct contact, fingerprint acquisition device. It is a high performance, low power, low cost, capacitive sensor composed of a two-dimensional array of metal electrodes in the sensing array. Each metal electrode acts as one plate of a capacitor and the contacting finger acts as the second plate. A passivation layer on the device surface forms the dielectric between these two plates. Ridges and valleys on the finger yield varying capacitor values across the array, and the resulting varying discharge voltages are read to form an image of the fingerprint.

The MBF300 sensor when combined with Sweep Sensor image capture software works by sliding your finger over the sensor surface. Rapid image capture software detects multiple fingerprint images and reconstructs the fingerprint minutia template.

The MBF300 is manufactured in standard CMOS technology. The 256 X 32 sensor array has a 50  $\mu\text{m}$  pitch and yields a 500-dpi image. The sensor surface is protected by a patented, ultra-hard, abrasion and chemical resistant coating.

### Packages

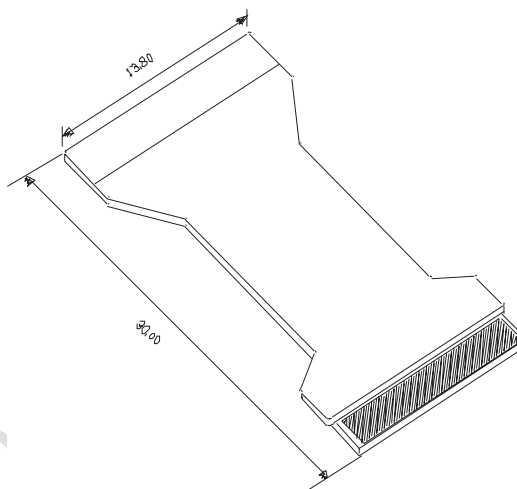

### Features

- Capacitive solid-state device
- 500-dpi resolution (50  $\mu\text{m}$  pitch)
- 1.28 cm x 0.16 cm sensor area
- 256 x 32 sensor array
- 2.8V to 5V operating range
- Exceptionally hard protective coating
- Integrated 8-bit analog to digital converter
- One of three bus interfaces:
  - 8-bit microprocessor bus interface
  - Integrated USB Full-Speed Interface
  - Integrated Serial Peripheral Interface
- Standard CMOS technology
- Low power, less than 70 mW operating at 5V

### Applications

- Secure access for databases, networks, local storage
- Portable fingerprint acquisition
- Smart Cards
- Identity verification for ATM transactions
- Cellular phone-based security access
- Access control and monitoring (home, auto, office, etc.)

## Table of Contents

Chip Operation .....	1
Block Diagram.....	1
Connection Diagram.....	2
Pin List.....	3
Pin Descriptions.....	4
Device Bus Operation.....	7
Microprocessor Bus Interface.....	7
Serial Peripheral Bus Interface (SPI) Slave .....	8
SPI Bus Mode.....	8
SPI Slave Mode.....	8
Register Read Command in SPI Slave Mode .....	8
Register Write Command for SPI Slave Mode.....	8
USB Interface Mode, Using Internal ROM .....	8
Endpoint 0 .....	8
Endpoint 1 .....	8
Endpoint 2 .....	8
USB Interface Mode, Using External ROM .....	8
SPI Master Mode .....	9
Function Register Descriptions .....	9
Function Register Map.....	9
RAH 0x00 .....	9
RAL 0x01.....	10
CAL 0x02.....	10
REH 0x03.....	10
REL 0x04.....	10
CEL 0x05 .....	10
DTR 0x06.....	11
DCR 0x07.....	11
CTRLA 0x08 .....	11
CTRLB 0x09.....	13
CTRLC 0x0A.....	14
SRA 0x0B.....	14
PGC 0x0C .....	15
ICR 0x0D .....	15
ISR 0x0E.....	16
CIDH 0x10 .....	16

# Solid State Fingerprint Sweep Sensor™

CIDL 0x11 .....	16
TST 0x12 .....	16
Sensor Initialization .....	17
Image Retrieval .....	17
Microprocessor Interface .....	17
Get Row .....	17
Get Whole Image .....	18
Get Sub-Image .....	19
Serial Peripheral Interface .....	20
Get Image .....	20
USB Interface .....	21
Get Image .....	21
Absolute Maximum Ratings .....	22
Operating Range .....	22
DC Characteristics .....	22
Power Supply Consumption .....	23
AC Characteristics .....	24
Microprocessor Bus Mode .....	24
Read Cycle .....	24
Write Cycle .....	24
SPI Slave Mode .....	25
SPI Master .....	25
Timing Diagrams .....	26
Physical Dimensions .....	30
Array Orientation .....	31
Appendix A .....	32
Recommended Power and Ground Connections .....	32

## Chip Operation

The sensor array includes 256 columns and 32 rows of sensor plates. Associated with each column are two sample-and-hold circuits. A fingerprint image is sensed or captured one row at a time. This “row capture” occurs in two phases. In the first phase, the sensor plates of the selected row are pre-charged to the VDD voltage. During this pre-charge period, an internal signal enables the first set of sample-and-hold circuits to store the pre-charged plate voltages of the row.

In the second phase, the row of sensor plates is discharged with a current source. The rate at which a cell is discharged is proportional

to the “discharge current.” After a period of time (referred to as the “discharge time”), an internal signal enables the second set of sample-and-hold circuits to store the final plate voltages. The difference between the precharged and discharged plate voltages is a measure of the capacitance of a sensor cell. After the row capture, the cells within the row are ready to be digitized.

The sensitivity of the chip is adjusted by changing the discharge current and discharge time. The nominal value of the current source is controlled by an external resistor connected between the ISET pin and ground. The current source is controlled from the Discharge Current Register (DCR). The discharge time is controlled by the Discharge Time Register (DTR).

## Block Diagram

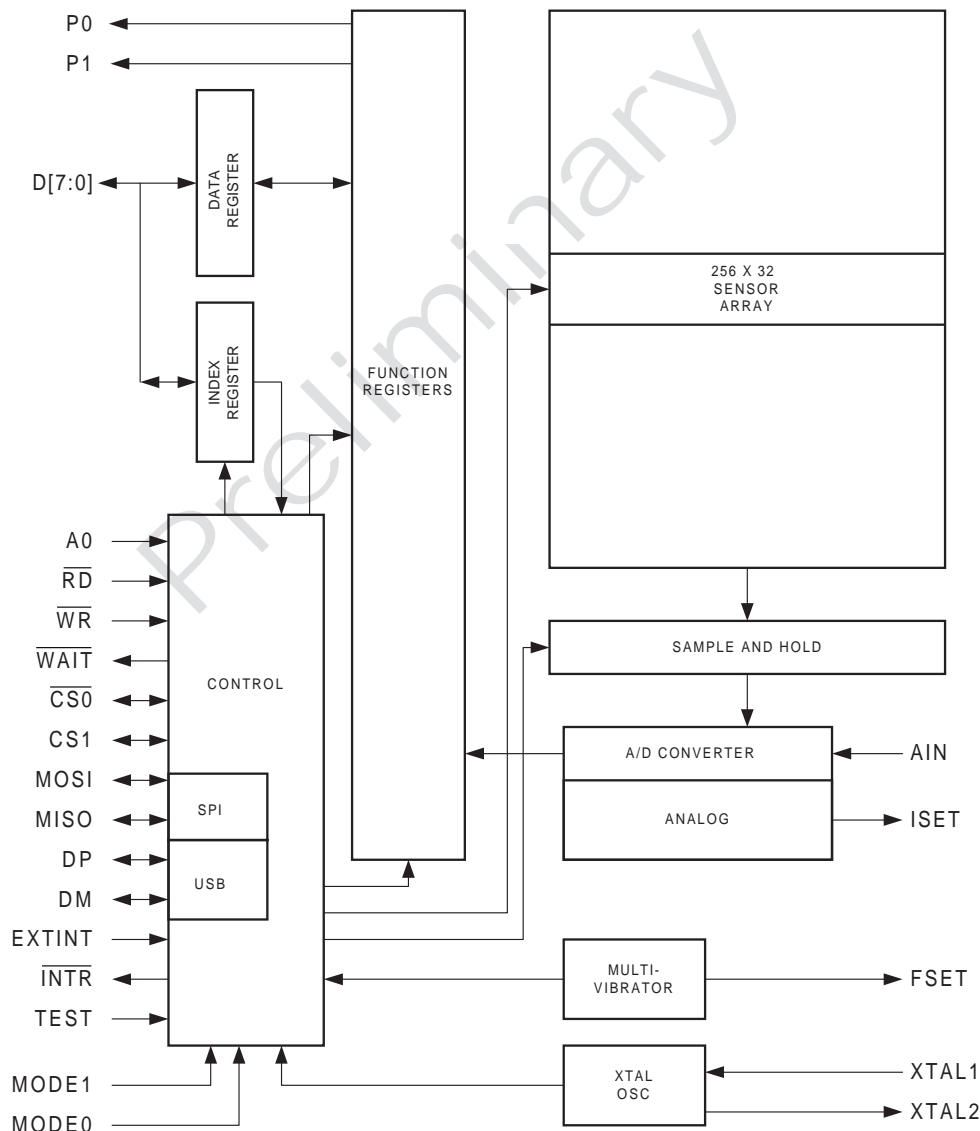

# Solid State Fingerprint Sweep Sensor™

## Connection Diagram

MBF300-FPC      PIN I/O

FACING CONTACT PADS

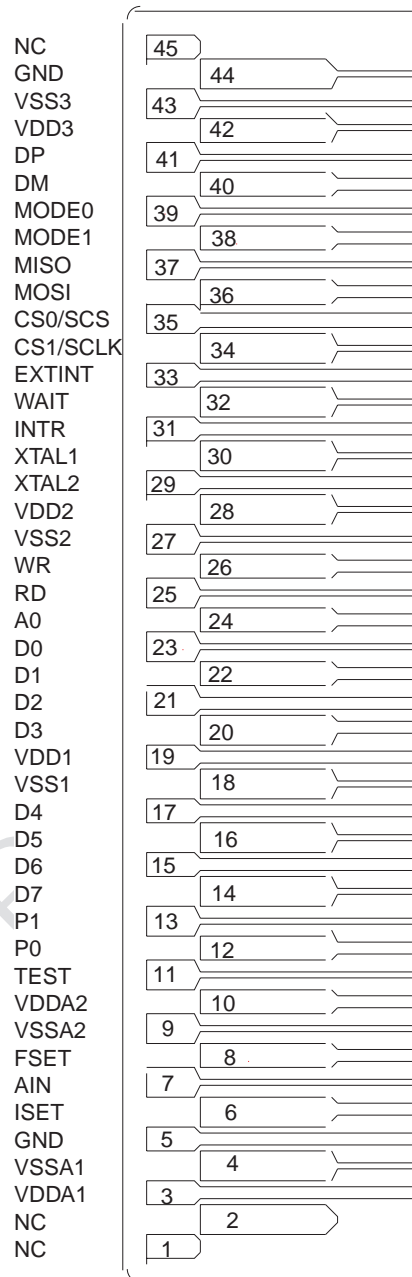

NOTE: NC (NO CONNECTION)

## Pin List

Pin Number	Name	Type	IOL (5.0 V)	IOH (5.0 V)	Description
1	NC				No Connect
2	NC				No Connect
3	VDDA1	PWR			Analog Power Supply
4	VSSA	GND			Analog Ground
5	VSSA	GND			Analog Ground
6	ISET	O			Sets Reference Current
7	AIN	I			Analog Input
8	FSET	O			Sets Internal Multi-vibrator Frequency
9	VSSA2	GND			Analog Ground
10	VDDA2	PWR			Analog Power Supply
11	TEST	I			Test Mode Enable
12	P0	O	8mA	4mA	Output Port 0
13	P1	O	8mA	4mA	Output Port 1
14	D7	I/O	8mA	4mA	Data Bit 7
15	D6	I/O	8mA	4mA	Data Bit 6
16	D5	I/O	8mA	4mA	Data Bit 5
17	D4	I/O	8mA		Data Bit 4
18	VSS1	GND			Digital Ground
19	VDD1	PWR			Digital Power Supply
20	D3	I/O	8mA	4mA	Data Bit 3
21	D2	I/O	8mA	4mA	Data Bit 2
22	D1	I/O	8mA	4mA	Data Bit 1
23	D0	I/O	8mA	4mA	Data Bit 0
24	A0	I			Address Input
25	$\overline{RD}$	I	8mA	4mA	Read Enable, Active Low
26	$\overline{WR}$	I	8mA	4mA	Write Enable, Active Low
27	VSS2	GND			Digital Ground
28	VDD2	PWR			Digital Power Supply
29	XTAL2	O			Internal Oscillator Output
30	XTAL1	I			Internal Oscillator Input
31	$\overline{INTR}$	O	8mA		Interrupt Output, Active Low
32	$\overline{WAIT}$	O	8mA		Wait, Active Low
33	EXTINT	I			External Interrupt Input
34	CS1/SCLK	I/O			Chip Select, Active High
35	$\overline{CS0/SCS}$	I/O			Chip Select, Active Low
36	MOSI	I/O	8mA	4mA	SPI Master Output / Slave Input
37	MISO	I/O	8mA	4mA	SPI Master Input / Slave Output
38	MODE1	I			Mode Select 1
39	MODE0	I			Mode Select 0
40	DM	I/O			USB D-
41	DP	I/O			USB D+
42	VDD3	PWR			Digital Power Supply
43	VDD	PWR			Digital Power Supply
44	VSSA	GND			Analog Ground
45	NC				No Connect

# Solid State Fingerprint Sweep Sensor™

## Pin Descriptions

### No Connect (Pins 1, 2, and 45)

Unconnected pins.

### VDDA1, VDDA2 (Pins 3 and 10)

Power Supply to the analog section of the sensor. VDDA1 powers the array, row drivers, column receivers, A/D converter, and sample/hold amplifier. VDDA2 powers the multi-vibrator and bias circuits.

### VSSA1, VSSA2 (Pins 4, 5, 9, and 44)

Ground for the analog section of the sensor. VSSA1 is the ground return for the array, row drivers, column receivers, A/D converter, and sample hold amplifier. VSSA2 is the ground return for the multi-vibrator and bias circuits.

### VDD1, VDD2, VDD3 (Pins 19, 28, and 42-43)

Power supply to the digital logic and I/O drivers. VDD2 powers the core digital logic, oscillators, phase-locked loops, and digital inputs. VDD1 and VDD3 supply power to the digital output circuits and USB transceivers.

### VSS1, VSS2, VSS3 (Pins 18 and 27)

Ground for the digital logic and I/O drivers.

VSS2 is the ground connection for the core digital logic, oscillators, phase-locked loops, and digital inputs. VSS1 and VSS3 are the ground connections for the digital outputs and USB transceivers.

### ISET (Pin 6)

Connect a 200k ohm resistor between ISET and analog ground VSSA1 to set the internal reference current. The discharge current is a scalar function of the internal reference current.

### AIN (Pin 7)

Alternate analog input to the A/D converter. Set the AINSEL bit in register CTRLA to select AIN as the input to the A/D converter. Pull this pin to ground, preferably with a resistor.

### FSET (Pin 8)

Connect a resistor between FSET and ground to set the internal multi-vibrator and automatic finger detection frequency. Use a 56k ohm resistor for standard 12 MHz ( $\pm 20\%$ ) multi-vibrator operation and 120KHz ( $\pm 20\%$ ) automatic finger detection sampling rate.

### XTAL1 (Pin 30)

Input to the internal oscillator. To use the internal oscillator, connect a crystal circuit to this pin. If an external oscillator is used, connect its output to this pin.

### XTAL2 (Pin 29)

Output from the internal oscillator. To use the internal oscillator, connect a crystal circuit to this pin. If an external oscillator is used, leave this pin unconnected.

### D[7:0] (Pins 14-17, 20-23)

Bi-directional data bus. D[7:0] have weak latches that hold the bus's state when not being driven. These pins may be left unconnected in SPI or USB mode.

**A0 (Pin 24)**

Address input. Drive A0 low to select the address index register. Drive A0 high to select the data buffer. A0 has a weak latch that holds the pin state when not being driven. This pin may be left unconnected in SPI or USB mode.

 **$\overline{RD}$  (Pin 25)**

Read enable, active low. To read from the chip, drive  $\overline{RD}$  low while  $\overline{WR}$  is high and the chip is selected.  $\overline{RD}$  has an internal, weak pull-up resistor and may be left unconnected in SPI or USB mode.

 **$\overline{WR}$  (Pin 26)**

Write enable, active low. To write to the chip, drive  $\overline{WR}$  low while  $\overline{RD}$  is high and the chip is selected.  $\overline{WR}$  has an internal, weak pull-up resistor and may be left unconnected in SPI or USB mode.

 **$\overline{CS0} / \overline{SCS}$  (Pin 35)**

Chip select, active low. The  $\overline{CS0} / \overline{SCS}$  pin has a weak latch that holds the pin's state when not being driven.  $\overline{CS0} / \overline{SCS}$  may be left unconnected in USB mode if not using an external serial ROM. The function of the  $\overline{CS0} / \overline{SCS}$  pin depends on the MODE1 and MODE0 pins.

**MODE[1:0] = 00b (Microprocessor Bus Interface Mode)**

$\overline{CS0} / \overline{SCS}$  functions as an active-low chip select input. Drive  $\overline{CS0} / \overline{SCS}$  low while CS1 is high to select the chip.

**MODE[1:0] = 01b (SPI Slave Mode)**

$\overline{CS0} / \overline{SCS}$  functions as an active-low slave chip select input. Connect a pull-up resistor between  $\overline{CS0} / \overline{SCS}$  and VDD.

**MODE[1:0] = 10b (USB Interface Mode, Using Internal ROM)**

$\overline{CS0} / \overline{SCS}$  has no function.

**MODE[1:0] = 11b (USB Interface Mode, Using External ROM)**

$\overline{CS0} / \overline{SCS}$  functions as the master chip select output, active low to the slave serial ROM chip select. Connect a pullup resistor between  $\overline{CS0} / \overline{SCS}$  and VDD.

**CS1 / SCLK (Pin 34)**

Chip select, active high. The CS1/SCLK pin has a weak latch that holds the pin's state when not being driven. CS1/SCLK may be left unconnected in USB mode if not using an external serial ROM. The function of this pin depends on the MODE1 and MODE0 pins.

**MODE[1:0] = 00b (Microprocessor Bus Interface Mode)**

CS1/SCLK functions as an active-high chip select input. Drive CS1/SCLK high while  $\overline{CS0} / \overline{SCS}$  is low to select the chip.

**MODE[1:0] = 01b (SPI Slave Mode)**

CS1/SCLK functions as the slave serial clock input.

**MODE[1:0] = 10b (USB Interface Mode, Using Internal ROM)**

CS1/SCLK has no function.

**MODE[1:0] = 11b (USB Interface Mode, Using External ROM)**

CS1/SCLK functions as the master serial clock output to the slave serial ROM clock input. Connect a pull-up resistor between CS1/SCLK and VDD.

**EXTINT (Pin 33)**

External Interrupt input. This pin can be programmed to be edge or level sensitive, active-high or active-low. EXTINT has a weak pull-up and may be left unconnected in MCU, SPI, or USB mode.



# Solid State Fingerprint Sweep Sensor™

## **$\overline{\text{INTR}}$ (Pin 31)**

Interrupt output, active low.  $\overline{\text{INTR}}$  is high impedance when it is not active and is driven low when an enabled interrupt event occurs.  $\overline{\text{INTR}}$  can be enabled if the sensor is in MCU or SPI mode. In USB mode leave this pin unconnected.

## **$\overline{\text{WAIT}}$ (Pin 32)**

Wait output, active low.  $\overline{\text{WAIT}}$  is driven low when active and high-impedance when not active.  $\overline{\text{WAIT}}$  goes low if the A/D converter is read while an A/D conversion is in progress.  $\overline{\text{WAIT}}$  will remain low until the A/D conversion is completed.

## **MOSI (Pin 36)**

SPI Master Output/Slave input. The MOSI pin has a weak latch that holds the pin's state when not being driven. MOSI may be left unconnected in MCU mode or USB mode if not using an external serial ROM. The function of this pin depends on the MODE1 and MODE0 pins.

### **MODE[1:0] = 00b (Microprocessor Bus Interface Mode)**

MOSI has no function.

### **MODE[1:0] = 01b (SPI Slave Mode)**

MOSI functions as the slave serial input.

### **MODE[1:0] = 10b (USB Interface Mode, Using Internal ROM)**

MOSI has no function.

### **MODE[1:0] = 11b (USB Interface Mode, Using External ROM)**

MOSI functions as the master serial data output to the slave serial ROM data input. Unlike standard SPI, MOSI is actively driven high and low when transmitting data and is high impedance when idle. Connect a pull-up resistor between MOSI and VDD to pull MOSI high when idle.

## **MISO (Pin 37)**

SPI Master Input/Slave Output. The MISO pin has a weak latch that holds the pin's state when not being driven. MISO may be left unconnected in MCU mode or USB mode if not using an external serial ROM. The function of this pin depends on the MODE1 and MODE0 pins.

### **MODE[1:0] = 00b (Microprocessor Bus Interface Mode)**

MISO has no function.

### **MODE[1:0] = 01b (SPI Slave Mode)**

MISO functions as the slave serial data output. Unlike standard SPI, the MISO connection is actively driven high and low when transmitting data and is high impedance when idle. Connect a pull-up resistor between MISO and VDD to pull MISO high when idle.

### **MODE1/MODE0 = 10b (USB Interface Mode, Using Internal ROM)**

MISO has no function.

### **MODE1/MODE0 = 11b (USB Interface Mode, Using External ROM)**

MISO functions as the master serial data input from the slave serial ROM data output.

## **P0 (Pin 12)**

Port Output 0. This output is controlled by bit 0 of the CTRLC register.

## **P1 (Pin 13)**

Port Output 1. This output is controlled by bit 1 of the CTRLC register.

## DP (Pin 41)

USB D+ data line. In USB mode, connect a 1.5k ohm resistor between DP and VDD3, which must be between 3.3V and 3.6V in this mode. Use a 43 ohm series resistor. In MCU or SPI mode, either pull-up this pin with a resistor or tie it to ground.

## DM (Pin 40)

USB D- data line. Use 43 ohm series resistor. In MCU or SPI mode, either pull-up this pin with a resistor or tie it to ground.

## MODE[1:0] (Pins 38 and 39)

Mode Select pins. MODE[1:0] select one of four operating modes.

MODE[1:0]	Description
00b	Microprocessor Bus Mode
01b	SPI Bus Mode
10b	USB Mode, Using Internal ROM
11b	USB Mode, Using External ROM

## TEST (Pin 11)

Test Mode Enable. It is intended for factory use only. Connect this pin to VSS.

## Device Bus Operation

### Microprocessor Bus Interface

The microprocessor bus interface mode uses the following pins: D[7:0], A0,  $\overline{RD}$ ,  $\overline{WR}$ ,  $\overline{CS0}$ , CS1, EXTINT,  $\overline{INTR}$ , and  $\overline{WAIT}$ . Either the internal multi-vibrator or the XTAL1/XTAL2 oscillator can be selected to provide the clock to the chip. The SPI and USB interfaces are disabled.

The fingerprint sensor chip uses an indexed addressing scheme to access its function registers. The chip has eight data lines (D[7:0]) and one address line (A0). The address line selects between the index register and the data register. Drive A0 low to select the index register. Drive A0 high to access the function register selected by the index register. The index register retains its value until it is rewritten or the chip is reset.

### Truth Table for the Microprocessor Bus Interface

$\overline{CS0}$	CS1	A0	$\overline{RD}$	$\overline{WR}$	Mode	Data Lines
H	X	X	X	X	De-selected	High Impedance
X	L	X	X	X	De-selected	High Impedance
L	H	X	H	H	Standby	High Impedance
L	H	L	L	H	Read Index Register	Output
L	H	L	H	L	Write Index Register	Input
L	H	H	L	H	Read Data Register	Output
L	H	H	H	L	Write Data Register	Input

The chip has four control inputs:  $\overline{CS0}$ , CS1,  $\overline{RD}$ , and  $\overline{WR}$ . Drive  $\overline{CS0}$  low and CS1 high to select the chip. Data is latched on the rising edge of  $\overline{WR}$ .

The chip has two status lines:  $\overline{INTR}$  and  $\overline{WAIT}$ . The  $\overline{INTR}$  signal is asserted when an interrupt event occurs. The  $\overline{WAIT}$  signal goes low when the A/D converter is read while an A/D conversion is in progress. The  $\overline{WAIT}$  signal will be high impedance when the A/D conversion is completed. Both the  $\overline{WAIT}$  and  $\overline{INTR}$  outputs are high impedance when they are not active. As a result, they can be active-low WIRE-ORed in conjunction with other interrupts or wait signals.

The SPI and USB interfaces are disabled when the microprocessor bus interface is selected. A truth table for the microprocessor bus interface is shown below:

# Solid State Fingerprint Sweep Sensor™

## Serial Peripheral Bus Interface (SPI) Slave

### SPI Bus Mode

SPI (Slave) bus mode uses the following pins: SCLK,  $\overline{\text{SCS}}$ , MOSI, MISO, and EXTINT. Either the internal multivibrator or the XTAL1/XTAL2 oscillator can be selected to provide the clock to the chip. The microprocessor bus and USB interface are disabled.

### SPI Slave Mode

In SPI Slave Mode, the sensor can operate in either SPI mode (0, 0) where CPOL = 0 and CPHA = 0 or SPI mode (1, 1) where CPOL = 1 and CPHA = 1. The SPI Master may clock in commands and clock out data up to 12 Mbits per second. The SPI Master can write and read the registers of the sensor even when the internal 12 MHz multivibrator or XTAL1/XTAL2 oscillator is halted.

- MOSI bits are sampled on the rising edge of SCK
- MISO bits change on the falling edge of SCK
- SCK can be idle in either a high or low state
- The most significant bits are shifted out first

### Register Read Command in SPI Slave Mode

The Register Read command includes a command byte and address byte. The command sequence begins when the SPI master drives  $\overline{\text{SCS}}$  low and sends the Read Command byte (encoded as 0x03) on the MOSI pin. Following the command byte, the master sends the address byte, which is the index to the register to be read. After receiving the least significant bit (LSB) of the address byte, the SPI slave sensor sends the contents of the selected register on the MISO pin. Finally, the master drives  $\overline{\text{SCS}}$  high after it has sampled the LSB of the data byte. When reading the A/D converter, the Master may keep  $\overline{\text{SCS}}$  low to read consecutive pixels up to the end of the current row. A new Register Read command must be issued to read the next row. The SPI Master must drive  $\overline{\text{SCS}}$  high before beginning another command.

### Register Write Command for SPI Slave Mode

The Register Write command includes a command byte and address byte followed by the data to be written. The command sequence begins when the SPI Master drives  $\overline{\text{SCS}}$  low and sends the Write Command byte (encoded as 0x02) on the MOSI pin. Then the master sends the address byte, which is the index to the register to be written. Finally, the master sends the data byte and thereafter drives  $\overline{\text{SCS}}$  high.

## USB Interface Mode, Using Internal ROM

This USB mode uses the following pins: DP, DM, EXTINT, XTAL1, and XTAL2. XTAL1 must be driven from a 12 MHz source or XTAL1 and XTAL2 must be connected to a 12 MHz crystal circuit. The internal 12 MHz multivibrator, the microprocessor bus, and SPI interface are disabled. The internal USB descriptor ROM will be accessed in response to a USB GET\_DESCRIPTOR command.

The sensor's USB interface uses three endpoints:

### Endpoint 0

Endpoint 0 is a control endpoint used for device enumeration and configuration. The sensor function registers are written and read using control transfers of vendor specific commands to endpoint 0.

### Endpoint 1

Endpoint 1 is a bulk-in endpoint specifically for reading the CTRLA register, which is the output buffer of the A/D converter. Data is transmitted in 64-byte packets except for the last packet of a GETROW operation which may be 64-bytes or less, depending on the row length.

### Endpoint 2

Endpoint 2 is an interrupt endpoint. In the event of an interrupt, the contents of the ISR (Interrupt Status Register) are transferred to endpoint 2.

## USB Interface Mode, Using External ROM

This USB mode uses the following pins: DP, DM, SCLK,  $\overline{\text{SCS}}$ , MOSI, MISO, EXTINT, XTAL1, and XTAL2. XTAL1 must be driven from a 12 MHz source or a 12 MHz crystal circuit must be connected to XTAL1 and XTAL2. The internal 12 MHz multivibrator and the microprocessor bus are disabled.

The SPI interface is enabled as an SPI Master. The external SPI serial ROM will be accessed in response to a USB GET\_DESCRIPTOR command. The internal USB descriptor ROM is disabled. This mode allows an external serial ROM to override the internal descriptor ROM.

Note: When the MBF300 is directly connected to USB in either of the modes above, the VDD and VDDA pins must be powered between 3.3V and 3.6V so that the MBF300 DP and DM pins do not drive the USB beyond 3.6V.

## SPI Master Mode

In SPI Master Mode the sensor operates in SPI mode (1,1) where CPOL = 1, and CPHA = 1. SCK is limited to 1 MHz.

- MOSI bits change on the falling edge of SCK
- MISO bits are sampled on the rising edge of SCK
- SCK is idle in the high state
- The most significant bits are shifted out first

## Function Register Descriptions

The function registers are accessed by indexed addressing. Write the index register to select a function register. Read or write the data register to access the contents of the function register. All registers can be read and written except as noted in the following descriptions.

## Function Register Map

Index	Name	Description	Read/Write Access
0x00	RAH	Row Address, High	R/W
0x01	RAL	Row Address, Low	R/W
0x02	CAL	Column Address, Low	R/W
0x03	REH	Row Address End, High	R/W
0x04	REL	Row Address End, Low	R/W
0x05	CEL	Column Address End, Low	R/W
0x06	DTR	Discharge Time Register	R/W
0x07	DCR	Discharge Current Register	R/W
0x08	CTRLA	Control Register A	R/W
0x09	CTRLB	Control Register B	R/W
0x0A	CTRLC	Control Register C	R/W
0x0B	SRA	Status Register A	R
0x0C	PGC	Programmable Gain Control Register	R/W
0x0D	ICR	Interrupt Control Register	R/W
0x0E	ISR	Interrupt Status Register	R/W
0x10	CIDH	Chip Identification, High	R
0x11	CIDL	Chip Identification, Low	R
0x12	TST	Test Mode Register	R/W

Note: In the following descriptions, “sub-image” means a rectangular region of the sensor array, up to and including the entire array.

### RAH 0x00

Row Address Register High.

Reset State: 0x00

This register holds the high order bit of the address of the first row of a sub-image.

Bit Number	Bit Name	Function
[7:1]	-	Reserved. Write 0 to these bits.
0	RA[8]	Most Significant Bit of Row Address Register

# Solid State Fingerprint Sweep Sensor™

## **RAL 0x01**

Row Address Register Low.

Reset State: 0x00

This register holds the low order byte of the address of the first row of a sub-image.

Bit Number	Bit Name	Function
[7:0]	RA[7:0]	Low eight bits of Row Address Register

## **CAL 0x02**

Column Address Register.

Reset State: 0x00

This register holds the address of the first column of a sub-image.

Bit Number	Bit Name	Function
[7:0]	CA[7:0]	Column Address Register

## **REH 0x03**

Row Address End Register High.

Reset State: 0x00

This register holds the most significant bit of the address of the last row of a sub-image.

Bit Number	Bit Name	Function
[7:1]	-	Reserved. Write 0 to these bits.
0	REND[8]	Most Significant Bit of Row Address Register

## **REL 0x04**

Row Address End Register Low.

Reset State: 0x00

This register holds the least significant byte of the address of the last row of a sub-image.

Bit Number	Bit Name	Function
[7:0]	REND[7:0]	Low eight bits of Row Address Register

## **CEL 0x05**

Column Address End Register.

Reset State: 0x00

This register holds the address of the last column of a sub-image.

Bit Number	Bit Name	Function
[7:0]	CEND[7:0]	Column Address Register

## DTR 0x06

Discharge Time Register

Reset State: 0x00

Bit Number	Bit Name	Function
[7]	-	Reserved. Write 0 to these bits.
[6:0]	DT[6:0]	Sets the discharge time in oscillator clock periods.

## DCR 0x07

Discharge Current Register

Reset State: 0x00

Bit Number	Bit Name	Function
[7:5]	-	Reserved. Write 0 to these bits.
[4:0]	DC[4:0]	Sets the discharge current rate.

## CTRLA 0x08

Control Register A.

Reset State: 0x00

Write this register to initiate image conversion. Read this register to read the A/D converter.

Bit Number	Bit Name	Function
7	-	Reserved. Write 0 to this bit.
6	-	Reserved. Write 0 to this bit.
5	-	Reserved. Write 0 to this bit.
4	-	Reserved. Write 0 to this bit.
3	AINSEL	0=Select Array for Conversion 1=Select External Analog Input Pin and Start Conversion
2	GETSUB	Initiates Auto-increment for sub-image
1	GETIMG	Initiates Auto-increment for whole image
0	GETROW	Initiates Auto-increment for selected row

The GETSUB, GETIMG, and GETROW bits select an image access mode and initiate an A/D conversion sequence. The AINSEL bit selects the input source to the A/D converter.

Set the GETSUB bit to initiate the capture of a rectangular sub-image defined by the RAH, RAL, CAL, REH, REL, and CEL registers. In CPU or SPI mode, the sub-image can be an arbitrary rectangle ranging from a single pixel to the entire array. In USB mode, the number of columns in the sub-image must be an integral multiple of 64.

Set the GETIMG bit to initiate the capture of a whole image starting from row zero and column zero through row 299 and column 255, regardless of the RAH, RAL, CAL, REH, REL, and CEL registers.

Set the GETROW bit to initiate the capture of a row specified by the RAH and RAL registers.

Writing a 1 to any of GETSUB, GETIMG, or GETROW abandons the current image access operation and restarts at the beginning of the sub-image, image, or row. Set at most one of these three bits. If more than one these three bits are set, image conversion will not start.

# Solid State Fingerprint Sweep Sensor™

Setting the GETROW bit causes the following events to happen:

- Row address loaded with contents of RAH and RAL register.
- Column address resets to zero
- Row capture automatically starts
- Analog to digital conversion of first pixel automatically starts

Setting the GETIMG bit causes the following events to happen:

- Row address resets to zero
- Column address resets to zero
- Row capture automatically starts
- Analog to digital conversion of first pixel automatically starts

Setting the GETSUB bit causes the following events to happen:

- Row address loaded with contents of RAH and RAL register
- Column address loaded with contents of CAL
- Row capture automatically starts
- Analog to digital conversion of first pixel automatically starts

Set the AINSEL bit along with one of the other three bits to begin the analog to digital conversion of the voltage on the AIN pin instead of the sensor array.

Writing 0 to the CTRLA register has no effect other than clearing AINSEL; the current image access operation is not abandoned.

Read CTRLA for the result of the A/D conversion. The rising edge of  $\overline{RD}$  causes the next A/D conversion to start.

Parameter Description	Max	Units
Rising Edge of $\overline{WR}$ to First Data Valid	28 + DT[6:0]	Clock Cycles
Rising Edge of $\overline{RD}$ to Next Data Valid	6	Clock Cycles

Note: DT[6:0] refers to the contents of the Discharge Time Register.

## CRTL B 0x09

Control Register B.

Reset State: CTRLB[7:6] = state of MODE[1:0].

CTRLB[5] = 1.

CTRLB [4:0] = 0, Chip is disabled, oscillator is stopped.

Bit Number	Bit Name	Function
[7:6]	MODE[1:0]	Reflects the state of the MODE[1:0] pins. These bits are read-only. Writing to these bits has no effect. Write 0 to these bits.
5	RDY	This is a read-only bit that indicates the status of the A/D Converter. 0 = A/D Conversion is in progress. 1 = A/D Converter is idle. Writing this bit has no effect. Write 0 to this bit.
4	-	Reserved. Write 0 to this bit.
3	-	Reserved, this bit has no effect.
2	AUTOINCEN	0 = Column and row addresses do not automatically increment after the A/D converter is read. 1 = Column addresses increment and another A/D conversion is initiated after the A/D converter is read. The row address increments at the end of each column.
1	XTALSEL	In USB mode this bit has no function. In CPU and SPI mode this bit selects the clock source for the digital logic. 0 = Selects the internal 12 MHz multi-vibrator. 1 = Selects the XTAL1 pin.
0	ENABLE	0 = Place the sensor array, digital, and analog block into low-power state (12 MHz clock is halted, A/D Converter is shut down). 1 = Enable the sensor array, digital, and analog blocks (12 MHz clock and A/D Converter are enabled).



# Solid State Fingerprint Sweep Sensor™

## CTRLC 0x0A

Control Register C. This register controls the behavior of general output port pins P0 and P1.

Reset State: 0x00

Bit Number	Bit Name	Function
[7:5]	PT1[2:0]	<p>Programs the toggle rate of the P1 pin. If PT1[2:0] = 000, then the P1 pin follows the state of the P1 bit. Otherwise PT1[2:0] selects the clock divisor to generate a square wave on the P1 pin.</p> <p>000 = P1 pin follows state of bit P1. 001 = clock divided by 2<sup>24</sup>. 010 = clock divided by 2<sup>23</sup>. 011 = clock divided by 2<sup>22</sup>. 100 = clock divided by 2<sup>21</sup>. 101 = Reserved. 110 = Reserved. 111 = Reserved.</p>
[4:2]	PT0[2:0]	<p>Programs the toggle rate of the P0 pin. If PT0[2:0] = 000, then the P0 pin follows the state of the P0 bit. Otherwise PT0[2:0] selects the clock divisor to generate a square wave on the P0 pin.</p> <p>000 = P0 pin follows state of bit P0. 001 = clock divided by 2<sup>24</sup>. 010 = clock divided by 2<sup>23</sup>. 011 = clock divided by 2<sup>22</sup>. 100 = clock divided by 2<sup>21</sup>. 101 = Reserved. 110 = Reserved. 111 = Reserved.</p>
1	P1	<p>General Purpose Output Port. When PT1[2:0] bits are 000, this bit controls the P1 pin. 0 = P1 pin low. 1 = P1 pin high.</p>
0	P0	<p>General Purpose Output Port. When PT0[2:0] bits are 000, this bit controls the P0 pin. 0 = P0 pin low. 1 = P0 pin high.</p>

## SRA 0x0B

Status Register A. Read Only. This register shadows the state of CTRLA.

Reset State: 0x00

Bit Number	Bit Name	Function
7	-	Reserved. Returns 0.
6	-	Reserved. Returns 0.
5	-	Reserved. Returns 0.
4	-	Reserved. Returns 0.
3	AINSEL	This bit is set or cleared when the AINSEL bit (CTRLA bit 3) is set or cleared by software.
2	GETSUB	This bit is set when the GETSUB bit (CTRLA bit 2) is set by software. This bit is cleared after the last byte is read.
1	GETIMG	This bit is set when the GETIMG bit (CTRLA bit 1) is set by software. This bit is cleared after the last byte is read.
0	GETROW	This bit is set when the GETROW bit (CTRLA bit 0) is set by software. This bit is cleared after the last byte is read.

## PGC 0x0C

Programmable Gain Control Register.

Reset State: 0x00

Bit Number	Bit Name	Function
[7:4]	-	Reserved. Write 0 to these bits. Returns 0 when read.
		Sets the gain of the amplifier. 0000 = 1.0 (default) 0001 = 0.25 0010 = 0.50 0011 = 0.75 0100 = 1.0 0101 = 1.25 0110 = 1.50 0111 = 1.75 1000 = 4.0 1001 = 1.0 1010 = 2.0 1011 = 3.0 1100 = 4.0 1101 = 5.0 1110 = 6.0 1111 = 7.0
[3:0]	PG[3:0]	

## ICR 0x0D

Interrupt Control Register.

Reset State 0x00.

This register controls the behavior of the two interrupt sources of the fingerprint sensor. Interrupt request 0 corresponds to the finger detect interrupt. Interrupt request 1 corresponds to the external interrupt pin EXTINT.

Set bits IE[1:0] to enable the corresponding interrupt. Disabling an interrupt prevents the interrupt event from causing the chip to assert  $\overline{INTR}$  or to send a packet on USB endpoint 2. However, the interrupt event is not prevented from setting its corresponding bit in the ISR register.

Set bits IM[1:0] to prevent an interrupt event from setting the corresponding bit in the ISR. Setting or clearing IM[1:0] will not clear ISR bits IR[1:0].

Set bits IT[1:0] to program the interrupts as edge or level sensitive. If IT1 is programmed as edge triggered, then IR1 (interrupt request 1) will be set by the falling edge of EXTINT.

Bit Number	Bit Name	Function
7	IP1	0=EXTINT Interrupt Polarity is Falling Edge or Active Low 1=EXTINT Interrupt Polarity is Rising Edge or Active High
6	-	This bit is reserved.
5	IT1	0=EXTINT Interrupt is Edge Triggered 1=EXTINT Interrupt is Level Triggered
4	-	This bit is reserved.
3	IM1	0=EXTINT Interrupt Not Masked 1=EXTINT Interrupt Masked
2	-	This bit is reserved.
1	IE1	0=EXTINT Interrupt Disabled 1=EXTINT Interrupt Enabled
0	-	This bit is reserved.

# Solid State Fingerprint Sweep Sensor™

## ISR 0x0E

Interrupt Status Register.

Reset State ISR[7:2] = 0.

ISR[1:0] = X. State is indeterminate after reset.

Read this register to determine source(s) of interrupt(s).

Write a 1 to IR[1:0] to acknowledge and clear the corresponding interrupt bit.

Bit Number	Bit Name	Function
[7:4]	-	Reserved. Write 0 to these bits. Returns 0 when read.
3	IS1	Reflects the state of the EXTINT Pin. Write 0 to this bit.
2	-	Reserved. Write 0 to this bit.
1	IR1	EXTINT Interrupt Request Pending.
0	-	Reserved, returns 0 when read.

## CIDH 0x10

Chip Identification Register High. This register holds the high order byte of the chip identification word.

Bit Number	Bit Name	Function
[7:0]	CIDH[7:0]	Returns 0x20 when read.

## CIDL 0x11

Chip Identification Register Low. This register holds the low order byte of the chip identification word.

Bit Number	Bit Name	Function
[7:0]	CIDL[7:0]	The return value depends on the Revision of the chip.

## TST 0x12

Test Mode Register. Reserved for factory use only.

Reset State 0x00.

Bit Number	Bit Name	Function
[7:0]	TST[7:0]	Reserved. Write only 0 to these bits.

## Sensor Initialization

The sensor should be enabled and its image parameters adjusted before beginning a GETIMG, GETROW, or GETSUB operation.

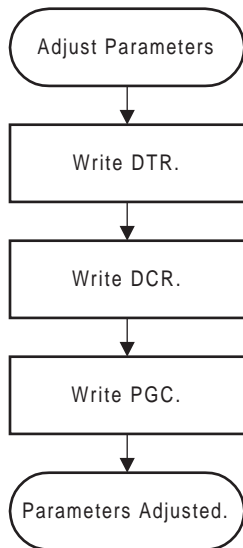
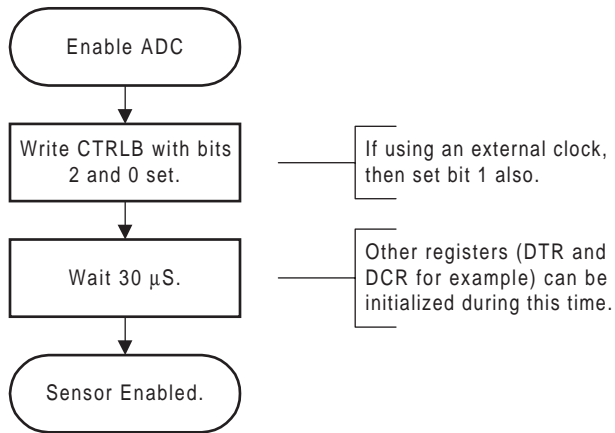

## Image Retrieval

### Microprocessor Interface

#### Get Row

First load the RAH and RAL registers with the address of the row to be fetched. Then write the CTRLA register to initiate a GETROW operation. Finally, read the CTRLA register 256 times to retrieve the row data.

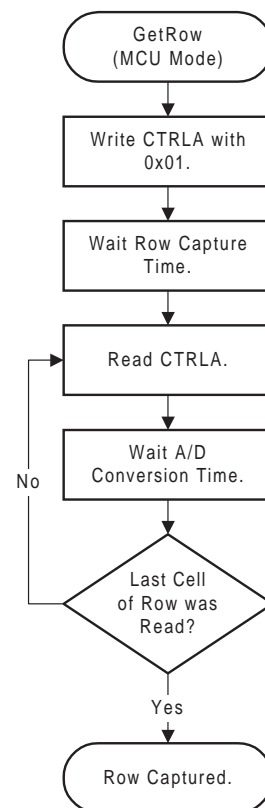
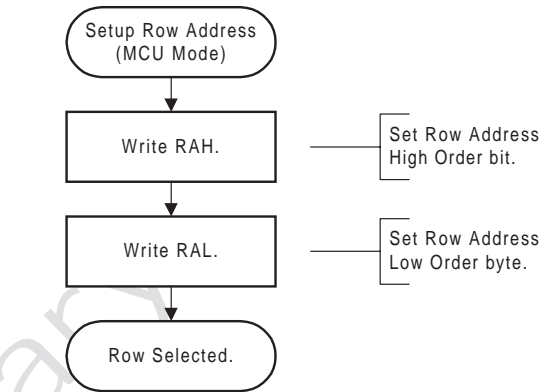

# Solid State Fingerprint Sweep Sensor™

## Get Whole Image

No row or column registers need to be loaded prior to starting a GETIMG operation. The sensor will automatically begin A/D conversion at row zero, column zero.

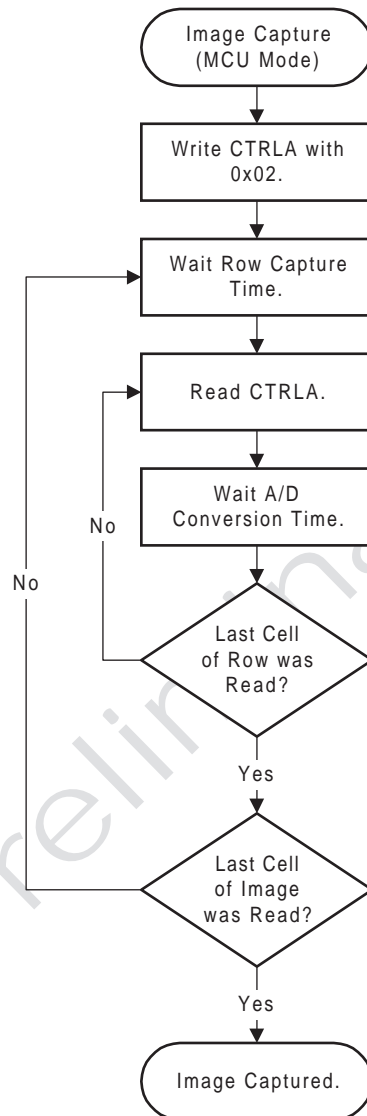

## Get Sub-Image

First, load the RAH, RAL, and CAL registers with the starting row and column address of the sensor sub-region. Then load registers REH, REL, and CEL with the ending row and column address of the sensor sub-region. Write the CTRLA register to initiate a GETSUB operation. Finally, read CTRLA register until the sub-image has been retrieved. The RAH, RAL, CAL, REH, REL, and CEL registers do not have to be loaded before each GETIMG operation unless a different sensor sub-region is to be captured.

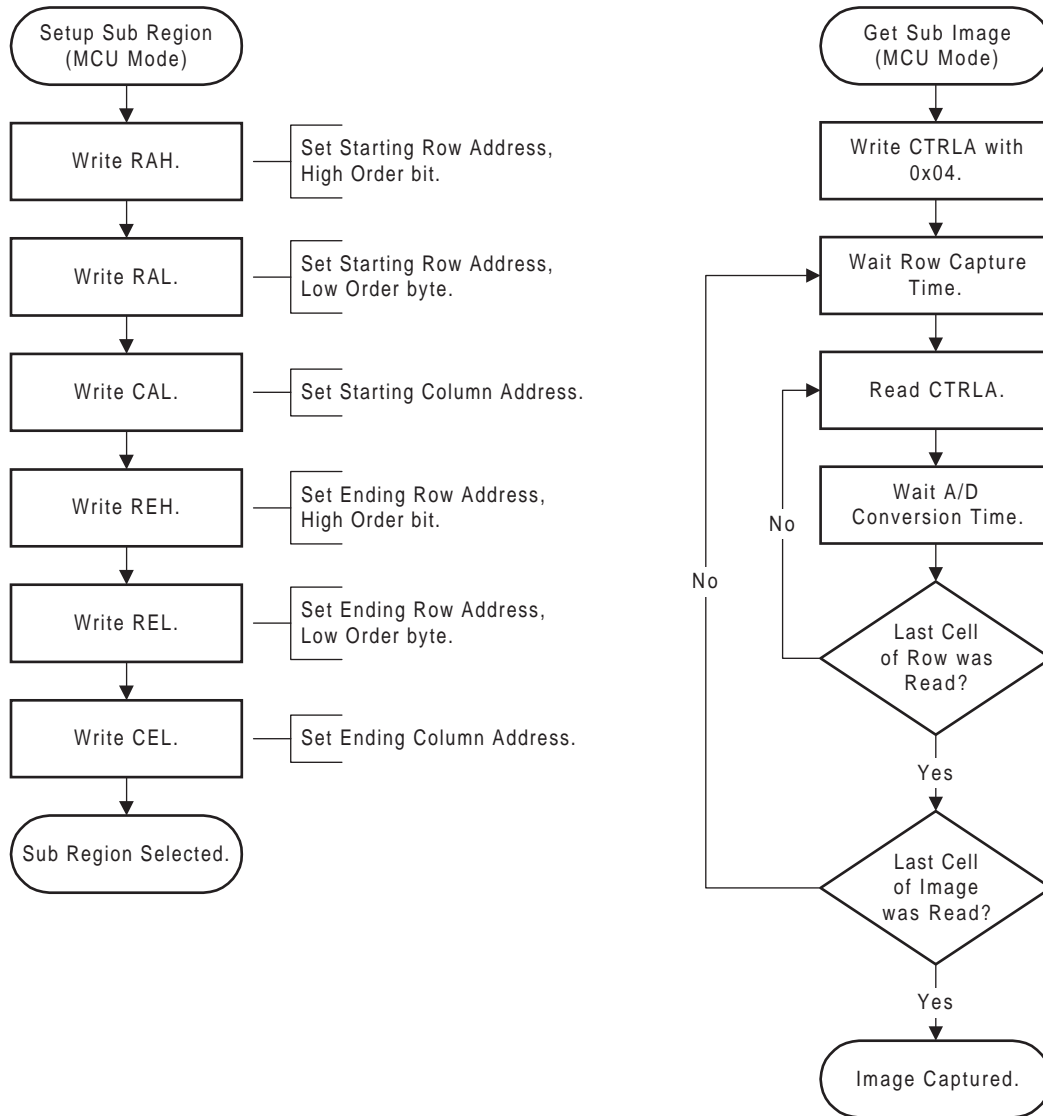

# Solid State Fingerprint Sweep Sensor™

## Serial Peripheral Interface

The “Get Image,” “Get Sub-Image,” and “Get Row” operations are initiated by writing the same registers as described in the microprocessor interface, except that the commands are written to the MOSI pin and the data is read back on the MISO pin. However, in SPI mode, an image or sub-image cannot be retrieved by issuing a single Register Read Command and shifting in the entire image; a separate Register Read Command must be issued prior to reading each row.

## Get Image

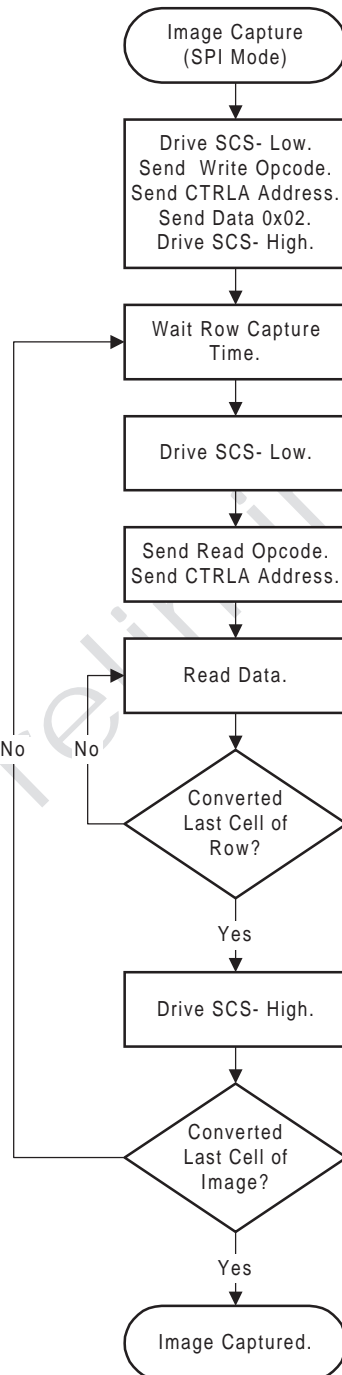

## USB Interface

The “Get Image,” “Get Sub-Image,” and “Get Row” operations are initiated by writing the same registers as described in the microprocessor interface, except that the registers are written and read on endpoint 0 and the image data is read from endpoint 1.

### Get Image

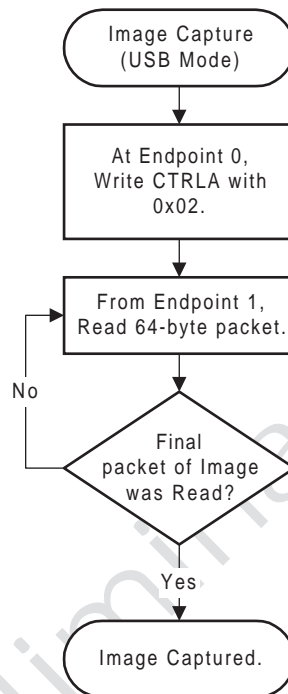



# Solid State Fingerprint Sweep Sensor™

## Absolute Maximum Ratings

Symbol	Rating	Value	Unit
V <sub>DD</sub>	Power Supply Voltage	+7.0	V
V <sub>IN</sub> , V <sub>OUT</sub>	Voltage on Any Pin Relative to VSS	-0.5 to +7.0	V
I <sub>OUT</sub>	Output Current per I/O	8.0	mA
T <sub>STG</sub>	Storage Temperature	-65 to +150	°C

Stresses above those listed under Absolute Maximum Ratings may cause permanent device failure. Functionality at or above these limits is not implied. Exposure to Absolute Maximum Ratings for extended periods may affect device reliability.

## Operating Range

Symbol	Description	Min	Max	Unit	
V <sub>DD</sub>	Supply Voltage		2.8	5.5	V
		USB Mode	3.3	3.6	V
T <sub>A</sub>	Ambient Temperature	0	60	°C	

## DC Characteristics

### (V<sub>DD</sub>=5.0V)

Symbol	Description	Test Conditions	Min	Max	Units
V <sub>IL</sub>	Input LOW Voltage	V <sub>DO</sub> = 4.5V	-0.5	0.8	V
V <sub>IH</sub>	Input HIGH Voltage	-	2.0	V <sub>DD</sub>	V
V <sub>OL</sub>	Output LOW Voltage	V <sub>DD</sub> = MIN, I <sub>OL</sub> = 8 mA	-	0.4	V
V <sub>OH</sub>	Output HIGH Voltage	V <sub>DD</sub> = MIN, I <sub>OH</sub> = -4 mA	2.4	-	V
I <sub>LI</sub>	Input Leakage Current	V <sub>DD</sub> = MAX, V <sub>IN</sub> = VSS to VDD	-5.0	5.0	μA
I <sub>LO</sub>	Output Leakage Current	V <sub>DD</sub> = MAX, V <sub>OUT</sub> = VSS to VDD, CE0- = V <sub>IH</sub> or CE1 = V <sub>IL</sub>	-5.0	5.0	μA

### (V<sub>DD</sub>=3.3V)

Symbol	Description	Test Conditions	Min	Max	Units
V <sub>IL</sub>	Input LOW Voltage	V <sub>DD</sub> = 3.0V	-0.5	0.6	V
V <sub>IH</sub>	Input HIGH Voltage		2.0	V <sub>DD</sub>	V
V <sub>OL</sub>	Output LOW Voltage	V <sub>DD</sub> = 3.6V, I <sub>OL</sub> = 4 mA	-	0.4	V
V <sub>OH</sub>	Output HIGH Voltage	V <sub>DD</sub> = 3.0V, I <sub>OH</sub> = -2 mA	2.4	-	V
I <sub>LI</sub>	Input Leakage Current	V <sub>DD</sub> = 3.6V V <sub>IN</sub> = VSS to VDD	-5.0	5.0	μA
I <sub>LO</sub>	Output Leakage Current	V <sub>DD</sub> = 3.6V, V <sub>OUT</sub> = VSS to VDD, CE0- = V <sub>IH</sub> or CE1 = V <sub>IL</sub>	-5.0	5.0	μA

## Power Supply Consumption

Symbol	Description	Test Conditions	Typ	Max	Units
<b>(Microprocessor Mode, VDD=5.0V f<sub>OSC</sub> = 20MHz)</b>					
I <sub>DD</sub>	Digital Current, Dynamic		TBD	5	mA
I <sub>DDSB</sub>	Digital Current, Standby		TBD	1	mA
I <sub>DDPDF</sub>	Digital Current, Power Down with Auto Finger Detection Enabled		TBD	10	μA
I <sub>DDPD</sub>	Digital Current, Power Down		TBD	10	μA
I <sub>DDA</sub>	Analog Current, Dynamic		TBD	20	mA
I <sub>DDASB</sub>	Analog Current, Standby		TBD	12	mA
I <sub>DDAPDF</sub>	Analog Current, Power Down with Auto Finger Detection Enabled		TBD	200	μA
I <sub>DDAPD</sub>	Analog Current, Power Down		TBD	10	μA
<b>(SPI Slave Mode, VDD=5.0V)</b>					
I <sub>DD</sub>	Digital Current, Dynamic		TBD	5	mA
I <sub>DDSB</sub>	Digital Current, Standby		TBD	1	mA
I <sub>DDPDF</sub>	Digital Current, Power Down with Auto Finger Detection Enabled		TBD	10	μA
I <sub>DDPD</sub>	Digital Current, Power Down		TBD	10	μA
I <sub>DDA</sub>	Analog Current, Dynamic		TBD	20	mA
I <sub>DDASB</sub>	Analog Current, Standby		TBD	12	mA
I <sub>DDAPDF</sub>	Analog Current, Power Down with Auto Finger Detection Enabled		TBD	200	μA
I <sub>DDAPD</sub>	Analog Current, Power Down		TBD	10	μA
<b>(Microprocessor Mode, VDD=3.3V)</b>					
I <sub>DD</sub>	Digital Current, Dynamic		TBD	5	mA
I <sub>DDSB</sub>	Digital Current, Standby		TBD	1	mA
I <sub>DDPDF</sub>	Digital Current, Power Down with Auto Finger Detection Enabled		TBD	10	μA
I <sub>DDPD</sub>	Digital Current, Power Down		TBD	10	μA
I <sub>DDA</sub>	Analog Current, Dynamic		TBD	15	mA
I <sub>DDASB</sub>	Analog Current, Standby		TBD	8	mA
I <sub>DDAPDF</sub>	Analog Current, Power Down with Auto Finger Detection Enabled		TBD	200	μA
I <sub>DDAPD</sub>	Analog Current, Power Down		TBD	10	μA
<b>(SPI Slave Mode, VDD=3.3V)</b>					
I <sub>DD</sub>	Digital Current, Dynamic		TBD	5	mA
I <sub>DDSB</sub>	Digital Current, Standby		TBD	1	mA
I <sub>DDPDF</sub>	Digital Current, Power Down with Auto Finger Detection Enabled		TBD	10	μA
I <sub>DDPD</sub>	Digital Current, Power Down		TBD	10	μA
I <sub>DDA</sub>	Analog Current, Dynamic		TBD	15	mA
I <sub>DDASB</sub>	Analog Current, Standby		TBD	8	mA
I <sub>DDAPDF</sub>	Analog Current, Power Down with Auto Finger Detection Enabled		TBD	200	μA
I <sub>DDAPD</sub>	Analog Current, Power Down		TBD	10	μA

# Solid State Fingerprint Sweep Sensor™

## Power Supply Consumption (continued)

Symbol	Description	Test Conditions	Typ	Max	Units
<b>(USB Mode, VDD=3.3V)</b>					
I <sub>DD</sub>	Digital Current, Dynamic		TBD	5	mA
I <sub>DDSB</sub>	Digital Current, Standby		TBD	1	mA
I <sub>DDPDF</sub>	Digital Current, Power Down with Auto Finger Detection Enabled		TBD	10	μA
I <sub>DDPD</sub>	Digital Current, Power Down		TBD	10	μA
I <sub>DDSPF</sub>	Digital Current, USB Suspend with Auto Finger Detection Enabled		TBD	10	μA
I <sub>DDSP</sub>	Digital Current, USB Suspend		TBD	10	μA
I <sub>DDA</sub>	Analog Current, Dynamic		TBD	30	mA
I <sub>DDASB</sub>	Analog Current, Standby		TBD	20	mA
I <sub>DDAPDF</sub>	Analog Current, Power Down with Auto Finger Detection Enabled		TBD	200	μA
I <sub>DDAPD</sub>	Analog Current, Power Down		TBD	10	μA

## AC Characteristics

### Microprocessor Bus Mode

#### Read Cycle

Symbol	Description	Min	Max	Units
t <sub>ACC</sub>	Address to Output Delay	5	35	ns
t <sub>CE</sub>	Chip Select to Output Delay	5	35	ns
t <sub>OE</sub>	Read Enable to Output Delay	5	35	ns
t <sub>OH</sub>	Output Hold Time from Address, $\overline{CS0}$ , CS1, or $\overline{RD}$ , which ever occurs first	5	-	ns
t <sub>DF</sub>	$\overline{RD}$ high to Output High Z	-	10	ns
t <sub>DF</sub>	$\overline{CS0}$ high or CS1 low to Output High Z	-	10	ns

#### Write Cycle

Symbol	Description	Min	Max	Units
t <sub>AS</sub>	Address Setup to $\overline{WR}$ low	0	-	ns
t <sub>CS</sub>	$\overline{CS0}$ Setup to $\overline{WR}$ low	0	-	ns
t <sub>CS</sub>	CS1 Setup to $\overline{WR}$ low	0	-	ns
t <sub>AH</sub>	Address Hold Time from $\overline{WR}$ high	5	-	ns
t <sub>CH</sub>	$\overline{CS0}$ Hold Time from $\overline{WR}$ high	0	-	ns
t <sub>CH</sub>	CS1 Hold Time from $\overline{WR}$ high	0	-	ns
t <sub>WP</sub>	$\overline{WR}$ Pulse Width Low	10	-	ns
t <sub>WPH</sub>	$\overline{WR}$ Pulse Width High	10	-	ns
t <sub>DS</sub>	Data Setup Time to $\overline{WR}$ low	8	-	ns
t <sub>DH</sub>	Data Hold Time to $\overline{WR}$ high	0	-	ns

## SPI Slave Mode

Symbol	Description	Min	Max	Units
$f_{SCK}$	SCLK Clock Frequency	-	12	MHz
$t_{CSS}$	$\overline{SCS}$ Setup Time	40	-	ns
$t_{CSH}$	$\overline{SCS}$ Hold Time	40	-	ns
$t_{WL}$	SCLK Low	40	-	ns
$t_{WH}$	SCLK High	40	-	ns
$t_{CS}$	$\overline{SCS}$ High Time	40	-	ns
$t_{SU}$	Data-In Setup Time	20	-	ns
$t_H$	Data-In Hold Time	20	-	ns
$t_V$	Data-Out Valid Time	20	30	ns
$t_{HD}$	Data-Out Hold Time	0	-	ns
$t_{DIS}$	Data-Out Disable Time	-	100	ns

## SPI Master

Symbol	Description	Min	Max	Units
$f_{SCKM}$	SCLK Clock Frequency	-	2	MHz
$t_{CSSM}$	$\overline{SCS}$ Setup Time	250	-	ns
$t_{CSHM}$	$\overline{SCS}$ Hold Time	-	250	ns
$t_{WLM}$	SCLK Low	-	250	ns
$t_{WHM}$	SCLK High	-	250	ns
$t_{CSM}$	$\overline{SCS}$ High Time	-	250	ns
$t_{SUM}$	Data-In Setup Time	-	100	ns
$t_{HM}$	Data-In Hold Time	-	250	ns
$t_{VM}$	Data-Out Valid Time	-	200	ns
$t_{HDM}$	Data-Out Hold Time	-	200	ns
$t_{DISM}$	Data-Out Disable Time	-	300	ns

# Solid State Fingerprint Sweep Sensor™

## Timing Diagrams

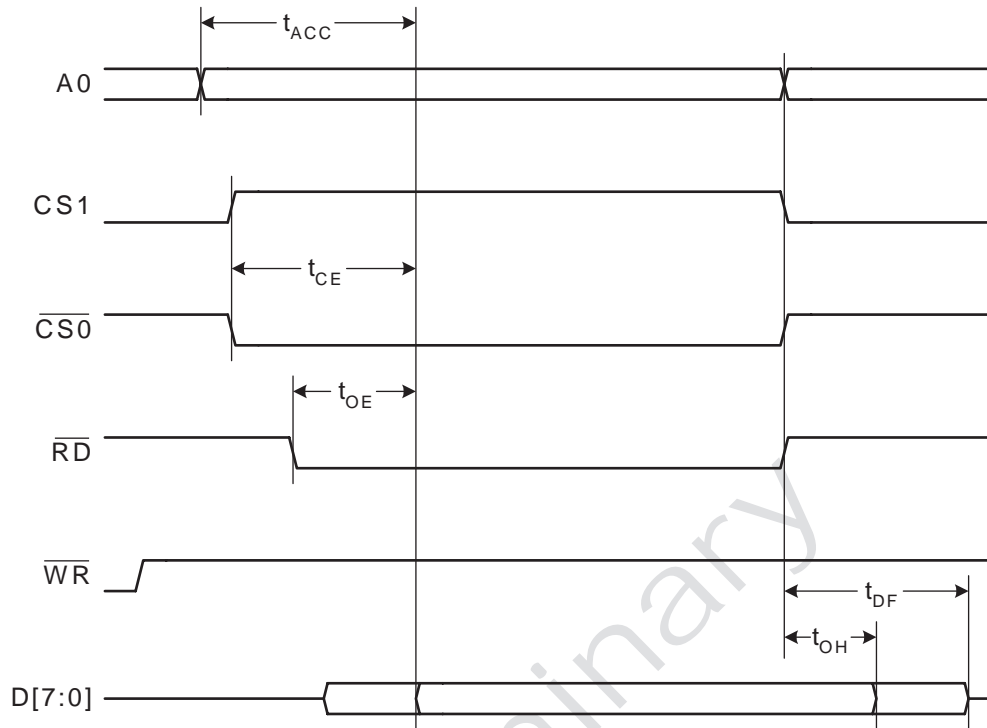

Figure 1. Microprocessor Mode Read Cycle

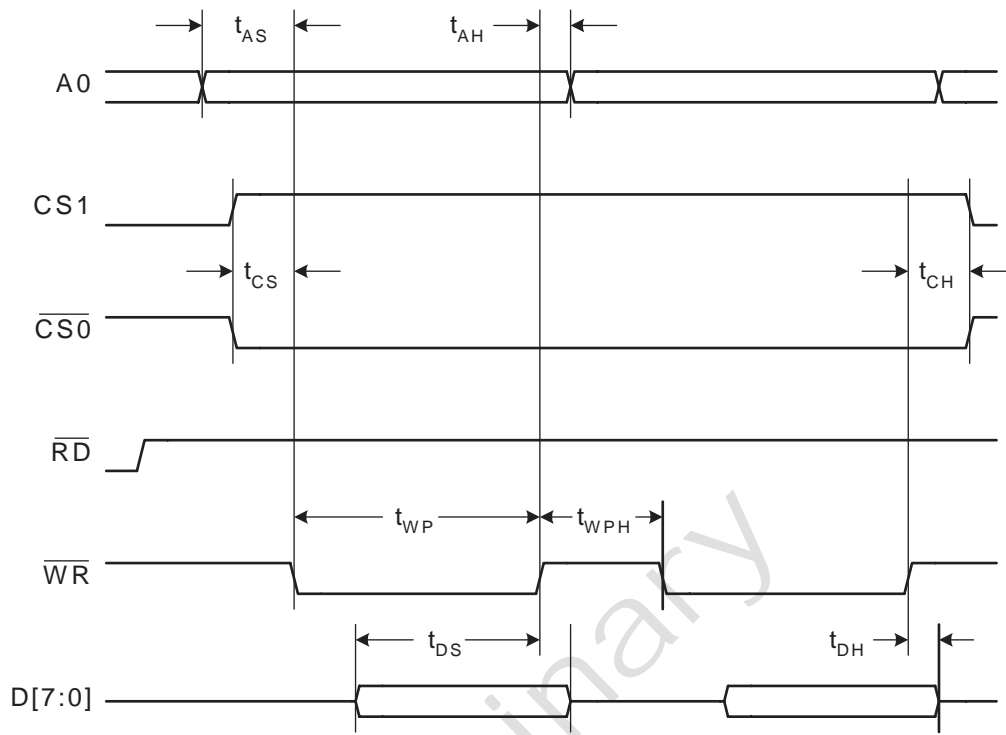

Figure 2. Microprocessor Mode Write Cycle

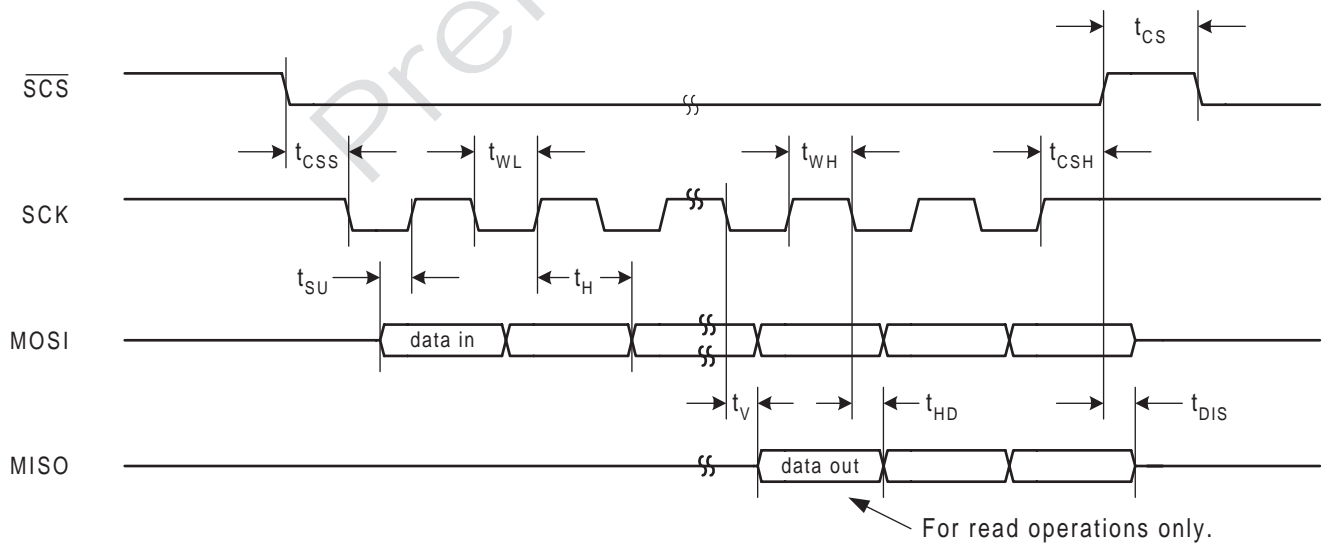

Figure 3. SPI Slave Mode Timing

# Solid State Fingerprint Sweep Sensor™

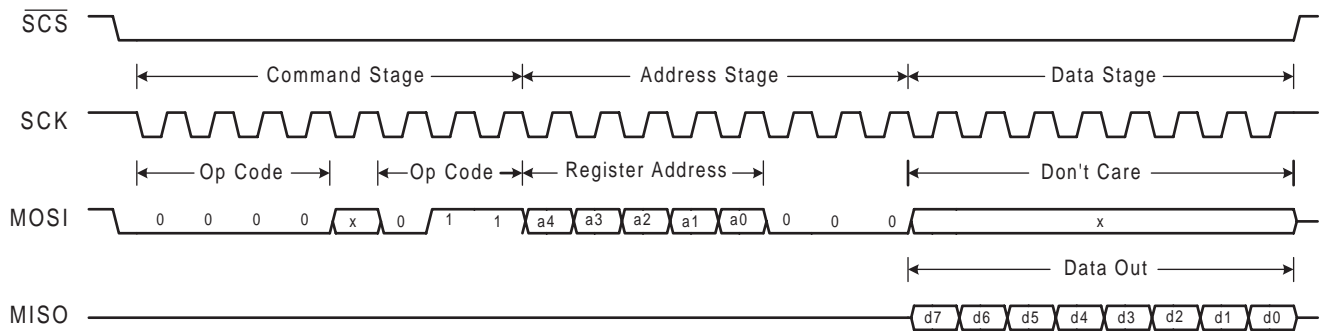

Figure 4. SPI Slave Mode Read Operation

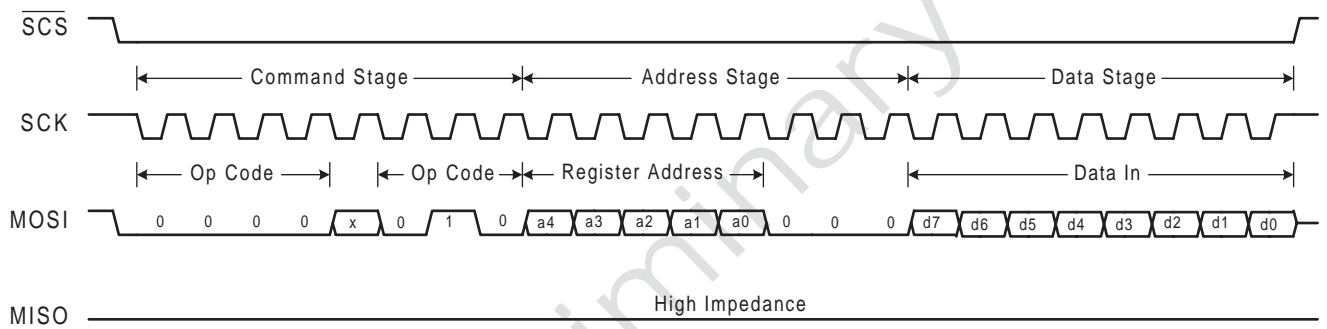

Figure 5. SPI Slave Mode Write Operation

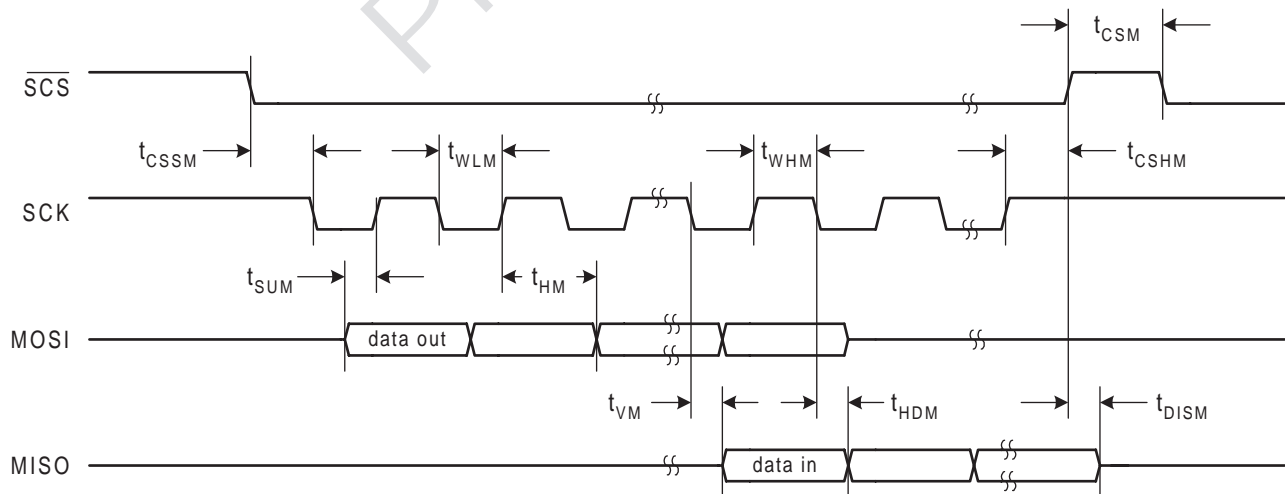

Figure 6. SPI Master Timing

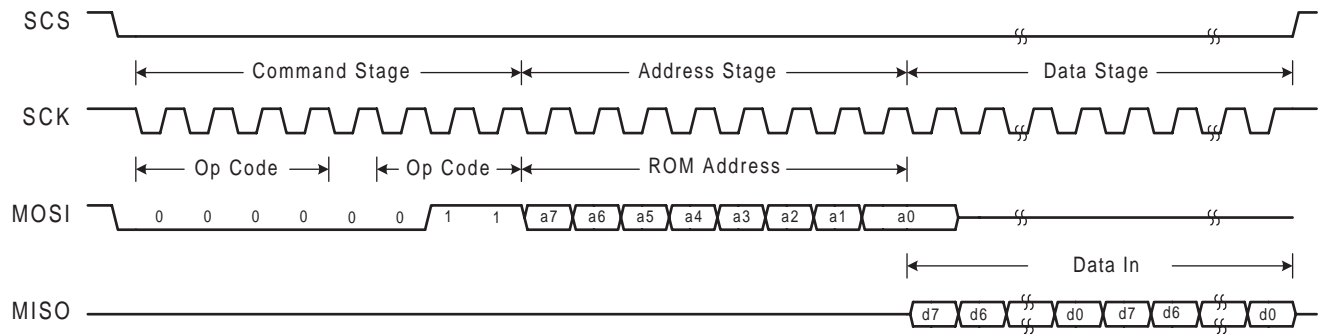

Figure 7. SPI Master Read Operation

Preliminary



# Solid State Fingerprint Sweep Sensor™

## Physical Dimensions

(all units in mm)

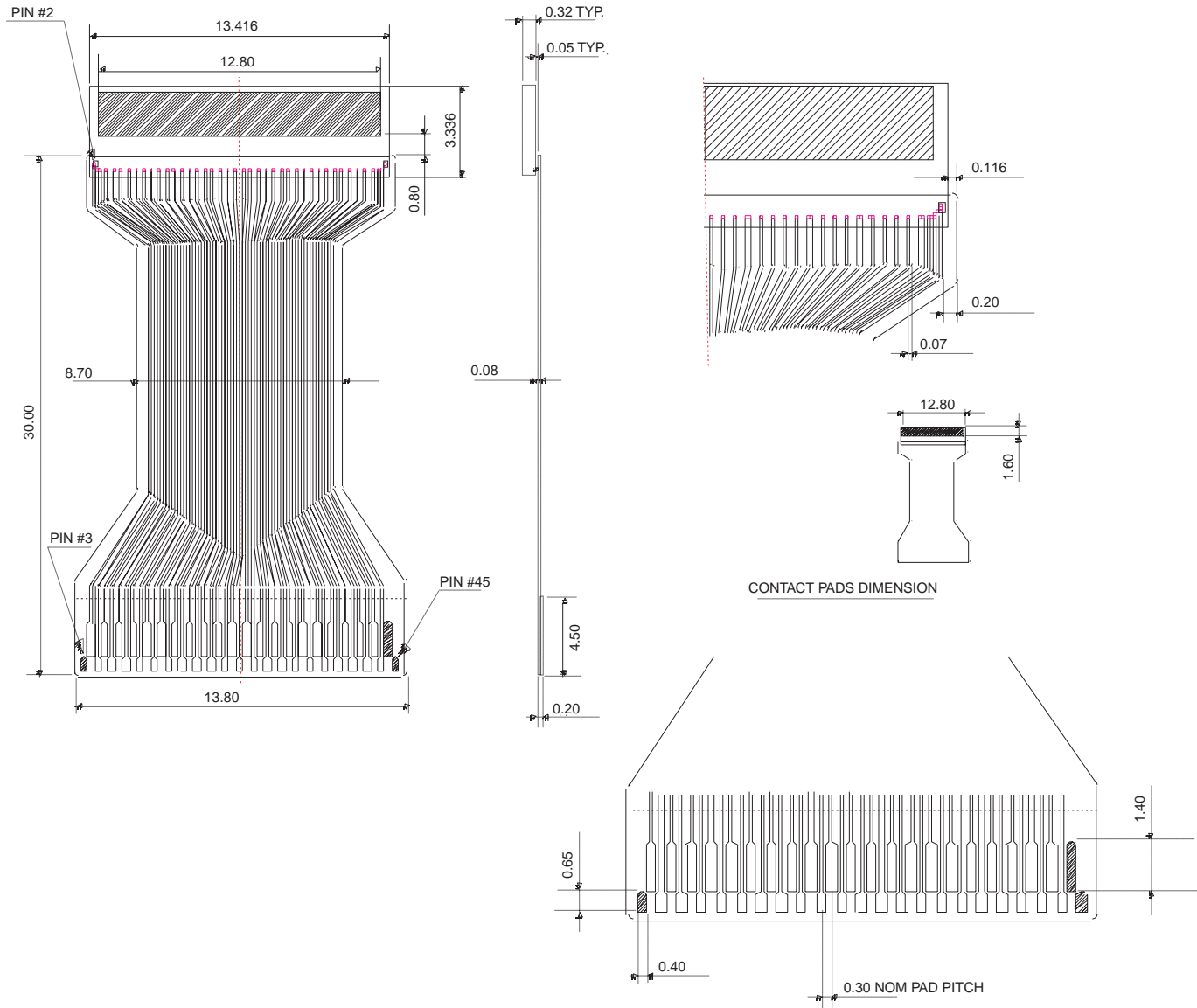

## Array Orientation

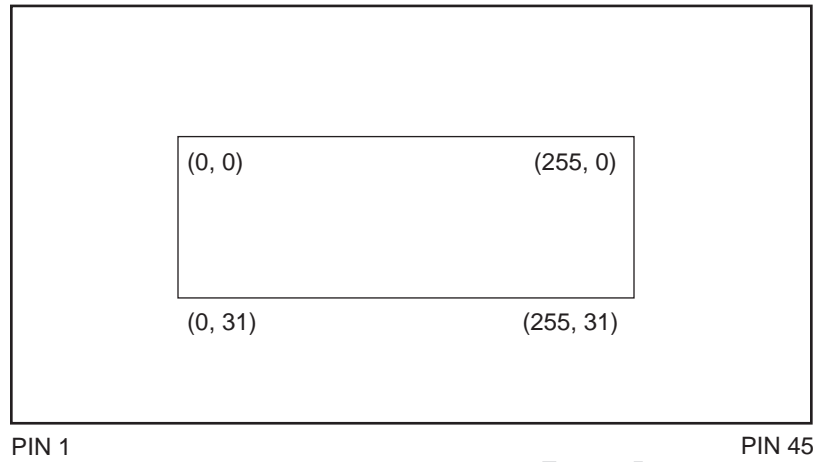

Preliminary

# Solid State Fingerprint Sweep Sensor™

## Appendix A

### Recommended Power and Ground Connections

The following describes the recommended method for reducing image noise to get the best image from the sensor.

VDDA1 (Pin 1) and VDDA2 (Pin 7) are the analog power supply pins. VSSA1 (Pin 2) and VSSA2 (Pin 6) are the ground returns. Connect one bulk capacitor (4.7 $\mu$ F to 10 $\mu$ F) and two 0.1 $\mu$ F capacitors in parallel between analog power and ground to provide filtering of low and high frequency noise. Place the bulk capacitor near VDDA1. Separate VDDA1 and VDDA2 from the digital power pins through a 10 ohm resistor.

VDD1 (Pin 16), VDD2 (Pin 25), and VDD3 (Pin 39) are the digital power supply pins. VSS1 (Pin 15), VSS2 (Pin 24), and VSS3 (Pin 40) are the ground returns. Place 0.1 $\mu$ F capacitors between digital power and ground, as close to the pins as possible.

Input signals that are to be tied high should not be shorted directly to VDD, but connected through a 1K to 10K ohm resistor in order to maximize ESD immunity of the sensor. A single resistor may be used for all inputs that are tied high.

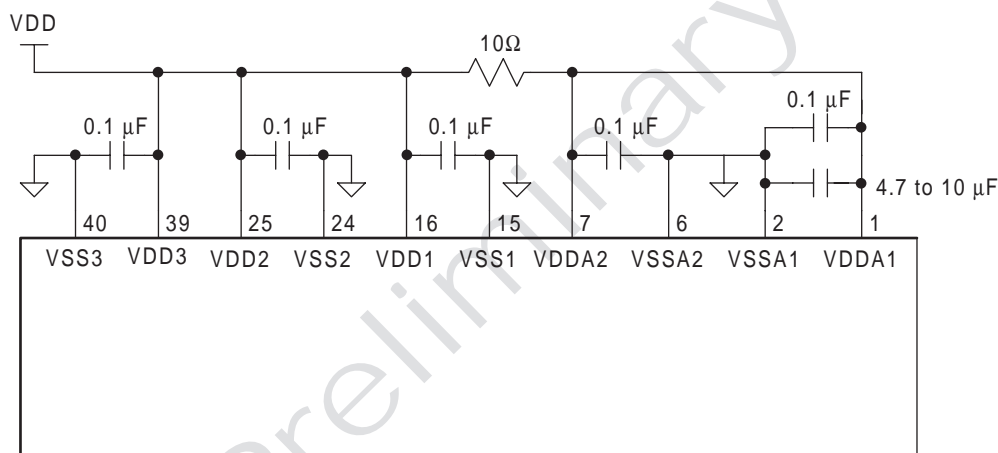

## Appendix B

### Recommended handling and operating procedure for MBF300-FPC

#### A. MBF300-FPC installation / Insertion to ZIF socket

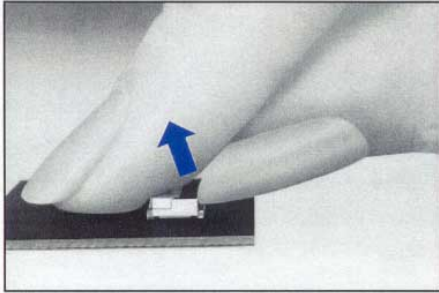

Lift carefully the actuator to disengage lid tab. Avoid too much pressure or forcefully lifting the lid tab in excess of 90° max. angle, as this may result to connector lid tab damage or potential solder joints crack.

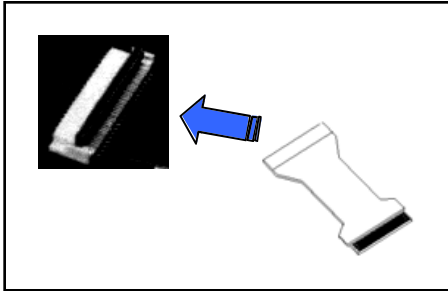

Insert the MBF300-FPC in the slot. The contact pads must be on a “faced down” direction. Ensure that the edge connector of the FPC is fully inserted.

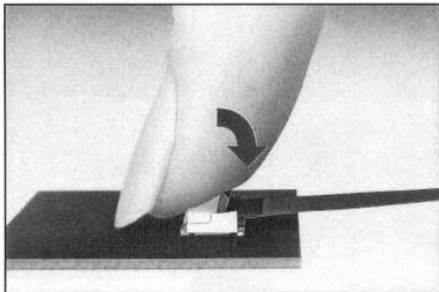

Push down and lock the lid tab. Slight click or snap will be felt once the lid tab is totally locked.

#### B. MBF300-FPC removal

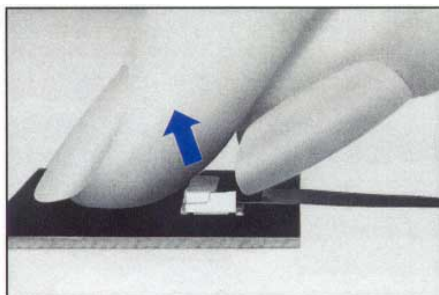

To unlock the socket, lift the lid tab up to 90°. Slide out the MBF300-FPC until completely set free.

Preliminary

## FUJITSU MICROELECTRONICS AMERICA, INC.

Corporate Headquarters

3545 North First Street, San Jose, California 95134-1804

Tel: (800) 866-8608 Fax: (408) 922-9179

E-mail: [fmacrc@fma.fujitsu.com](mailto:fmacrc@fma.fujitsu.com) Web Site: <http://www.fma.fujitsu.com>

©2002 Fujitsu Microelectronics America, Inc. All rights reserved.

All company and product names are trademarks or registered trademarks of their respective owners.

Printed in U.S.A.

BMS-DS-20936-6/2002