

# DSTINIs400/DSTINIs-00x Sockets Evaluation Board

[www.maxim-ic.com](http://www.maxim-ic.com)

## GENERAL DESCRIPTION

The TINI<sup>®</sup> sockets boards are motherboards designed to host the corresponding TINI evaluation module. The combination of the two boards allows full evaluation of the features of the target microprocessor. To evaluate the DS80C400, order both a DSTINIm400 and a DSTINIs400.

Although various boards support different evaluation modules, the most popular is the DSTINIs400. It includes a 144-pin SODIMM connector and provides 1-Wire<sup>®</sup>, CAN2.0B, serial, and a 10/100 Ethernet PHY for connecting the TINIm400 to the physical world.

The DSTINIm400 and DSTINIs400 are fully assembled and tested circuit boards. When used together they form a complete evaluation system for the DS80C400 network microcontroller. The DSTINIm400 module includes the DS80C400 network microcontroller, a real-time clock, 1MB flash, 1MB static RAM, and support for an external Ethernet PHY for connecting to a wide variety of networks. The circuit board is designed as a module to be plugged into the 144-pin SODIMM connector on the DSTINIS400.

Detailed information about the initial setup process and use of the TINI platform is contained in *Application Note 612: Getting Started with the TINIm400 (DS80C400) Verification Module*.

TINI and 1-Wire are registered trademarks of Dallas Semiconductor.

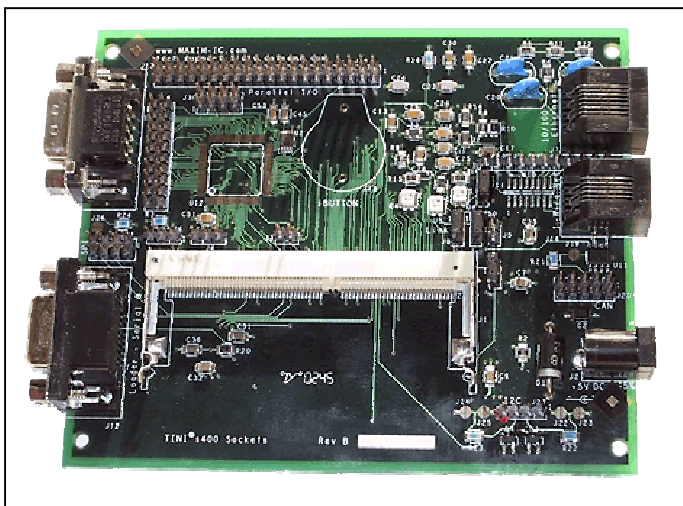

## FEATURES

- Hosts the TINI Runtime Environment in Validated Hardware Design (in Conjunction with the DSTINIm400)
- 10/100 Base-T Ethernet Port
- Two Serial Ports
- Dual 1-Wire Network Ports
- CAN2.0B Port
- 5.0V Single-Supply Operation (DSTINIm400)
- Fully Assembled and Tested Design

## ORDERING INFORMATION

PART	INPUT VOLTAGE*	USED WITH MODULE	DIMENSIONS
DSTINIs400	5V DC regulated	DSTINIm400	12cm x 10cm
DSTINIs-005	5V DC regulated	DSTINI1-1MG, DSTINI1-512	16cm x 10cm
DSTINIs-006	9V to 18V DC	DSTINI1-1MG, DSTINI1-512	16cm x 10cm

\*The user must supply an external power supply.

## COMPONENT LIST

DESIGNATION	QTY	DESCRIPTION
C1	1	47pF capacitor (1206)
C2, C4–C6	4	47µF capacitors (1206)
C3, C7, C9, C13, C15, C26, C28, C30, C38	9	100nF capacitors (1206)
C12, C14, C17, C19, C25, C27, C29, C33, C37	9	10nF capacitors (1206)
C8	1	220nF capacitor (1206)
C10, C31, C32, C34–C36	6	1.0µF capacitors (1206)
C11	1	4.7µF capacitor (1206)

**COMPONENT LIST (continued)**

DESIGNATION	QTY	DESCRIPTION
C16, C18	2	270pF capacitor (1206)
C20–C22	3	1nF, 2kV thru-hole capacitors
C23, C24	2	27pF capacitors (1206)
D1	1	1N5908 D0-201
D2	1	BAT54 SOT-23
J1	1	SODIMM144 Hirose SX6E-144S-0.8SH
J2	1	2.5mm center, 5.5mm outside barrel connector
J7	1	RJ-45 modular jack
J9–J11	3	3 x 1-pin headers, 0.1 centers
J12	1	DB9 serial female
J13	1	DB9 serial male
J14	1	Pad jumper
J16	1	RJ11 modular jack
L1	1	22 $\mu$ H inductor
R1	1	205k $\Omega$ , $\pm$ 1% resistor (1206)
R2	1	121k $\Omega$ , $\pm$ 1% resistor (1206)
R4–R7, R8, R10–R12	8	49.9 $\Omega$ , $\pm$ 1% resistors (1206)
R13, R9	2	47 $\Omega$ resistor (1206)
R14	1	22.1k $\Omega$ , $\pm$ 1% resistor (1206)
R15, R17, R18	3	220 $\Omega$ resistors (1206)
R16	1	10k $\Omega$ resistor (1206)
R19	1	Pad jumper

DESIGNATION	QTY	DESCRIPTION
R20	1	47k $\Omega$ resistor (1206)
R21	1	124 $\Omega$ , $\pm$ 1% resistor (1206)
R22, R23	2	1k $\Omega$ resistor (1206)
R24	1	10k $\Omega$ resistor (1206)
T1	1	BelFuse S558-5999-T7 transformer
U1	1	MAX1692 PWM step-down regulator
U3	1	Intel LXT972ALC Ethernet PHY
U4–U6	3	Dialight 597-7741 LED
U7	1	MAX560CAI transceiver
U8	1	DS2480B serial 1-Wire line driver
U9	1	DS9502 ESD protection diode
Y1	1	25.000MHz, HC49
Z1–Z3	3	Ferrite Bead, Fair-Rite 2512067007Y3
<b>UNPOPULATED COMPONENTS</b>		
J15	1	DS9094F iButton <sup>®</sup> Clip
J18, J28–J30	1	Not used
U2	1	MAX1792EUA18 linear regulator
U10	1	DS2408 1-Wire 8-channel addressable switch
U12	1	Not used

**JUMPERS (DSTINIS400)****Network Boot Jumper (J3)**

JUMPER	CONFIGURATION
1–2	DS80C400 attempts to boot through Ethernet using DHCP and TFTP

**Quiet Boot Jumper (J5)**

JUMPER	CONFIGURATION
1–2	DS80C400 boots without sending loader information to serial port.

**Auto Negotiation Jumper (J9)**

JUMPER	CONFIGURATION
1–2	Auto-negotiation disabled.
2–3	Auto-negotiation enabled.

**10/100Mb Ethernet Jumper (J10)**

JUMPER	CONFIGURATION
1–2	100Mb Ethernet operation.
2–3	10Mb Ethernet operation.

**Full Duplex Jumper (J11)**

JUMPER	CONFIGURATION
1–2	Ethernet is configured for full-duplex operation.
2–3	Ethernet is configured for half-duplex operation.

**DTR Reset Jumper (J11)**

JUMPER	CONFIGURATION
1–2	DTR reset is used for communication with the DS80C400 loader application.

iButton is a registered trademark of Dallas Semiconductor.

## PIN HEADERS

CONNECTOR	DESCRIPTION
J18	<b>Recreated I/O Port.</b> Latched from 1-Wire bus. Requires installation of DS2408. See schematic.
J20	<b>CAN Bus.</b> See schematic for pinout.
J21	<b>SPI™ Bus.</b> See schematic for pinout. Alternately provides connection to P5.4–P5.7
J27	<b>I<sup>2</sup>C™ Bus.</b> See schematic for pinout. Alternately provides connection to P1.0 and P1.1.
J28	<b>Unused.</b> No user-accessible pins available.
J29	<b>Unused.</b> No user-accessible pins available.
J30	<b>Unused.</b> No user-accessible pins available.

## QUICK START

### Recommended Equipment

The sockets board requires an external power supply and cables as needed to access the desired features of the board. The 5V DC power supply is mandatory, but the other cables are required only if that feature is to be used. The specific example shown here is for a TINIm400/TINIs400 system.

#### Hardware:

##### 5V DC Power Supply

Input Voltage: per customer requirements

Output Voltage: 5V DC  $\pm$ 10%

Output Current: >150mA

Polarization: Positive Center

Output Plug Type: 2.5mm I.D. x 5.5mm O.D. x 12mm Female (P-6)

Example: Digi-Key ([www.digikey.com](http://www.digikey.com)) part number T309-P6P-ND (110V input), 5V DC power

#### Ethernet Cable:

Note: There are two types of Ethernet cable. For connection to a router or hub, use a standard "straight-through" Ethernet cable. For direct connection to an Ethernet port on the back of a PC, use a "crossover" Ethernet cable. A crossover cable is specially made for two-computer networking. These cables can be purchased from almost any computer or electronics store.

Example (straight-through): Radio Shack ([www.radioshack.com](http://www.radioshack.com)) Cat 5E (3ft) Network Cable, part number 278-1763

Example (crossover): Radio Shack Cat 5E (3m) Crossover Cable, part number 278-2011

#### RS-232C Serial Cable (DB9 Male to DB9 Female):

This cable is straight-through, not a null-modem (crossover). These cables can be purchased from any computer or electronics store.

*SPI is a trademark of Motorola, Inc.*

*I<sup>2</sup>C is a trademark of Philips Corp. Purchase of I<sup>2</sup>C components of Maxim Integrated Products, Inc., or one of its sublicensed Associated Companies, conveys a license under the Philips I<sup>2</sup>C Patent Rights to use these components in an I<sup>2</sup>C system, provided that the system conforms to the I<sup>2</sup>C Standard Specification as defined by Philips.*

## MORE INFORMATION

TINI platform details can be found at [www.maxim-ic.com/TINI](http://www.maxim-ic.com/TINI). The *TINI Specification and Developer's Guide* (Addison-Welsey, 2001) is an invaluable resource when developing with the TINI platform. Download a free copy from our website at [www.maxim-ic.com/TINIGuide](http://www.maxim-ic.com/TINIGuide).

## Additional Resources

For detailed information about the initial setup and use of the TINI platform, refer to *Application Note 612: Getting Started with the TINIm400 (DS80C400) Verification Module* at [www.maxim-ic.com/appnoteindex](http://www.maxim-ic.com/appnoteindex).

DS80C400 network microcontroller data sheet: [www.maxim-ic.com/DS80C400](http://www.maxim-ic.com/DS80C400)

Microcontroller Website: [www.maxim-ic.com/microcontrollers](http://www.maxim-ic.com/microcontrollers)

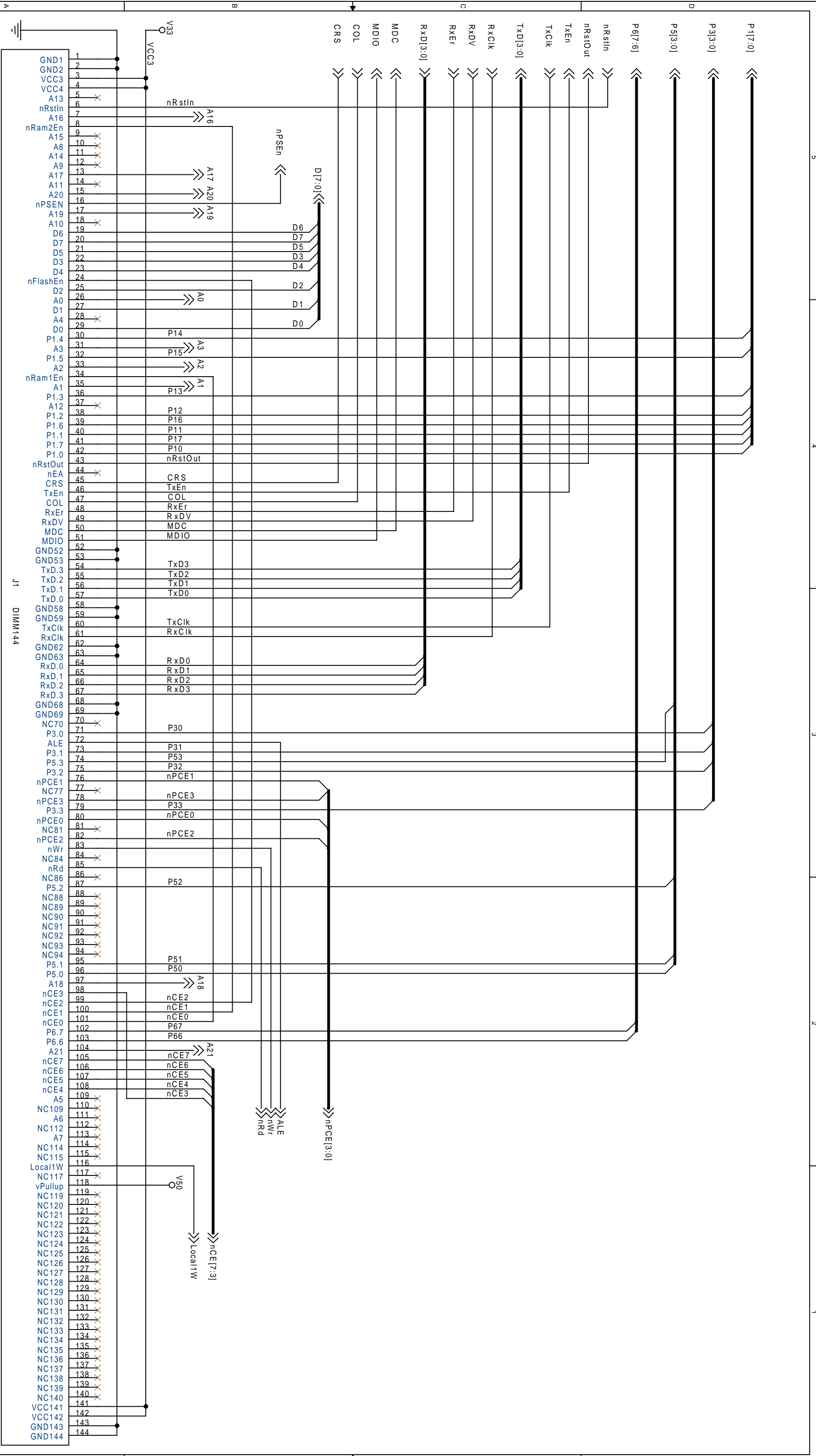

J1 DIMM144

Title		TINI400 Socket Board: TINI Module Connector	
Size		Document Number	
B		TINI400	
Date:		Monday, March 04, 2002	
Sheet		1 of 7	
Rev		B	

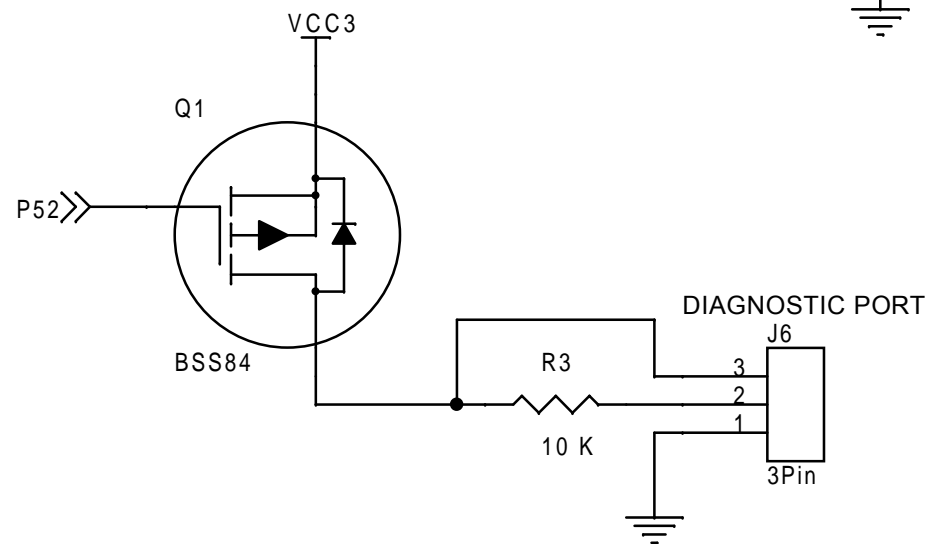
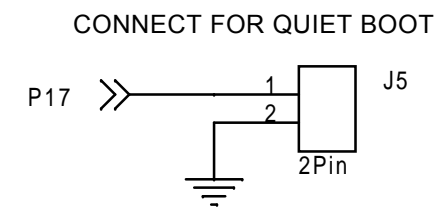
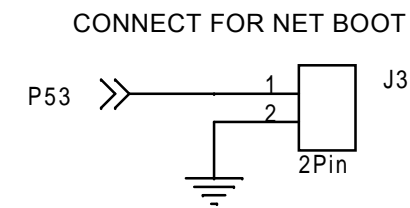
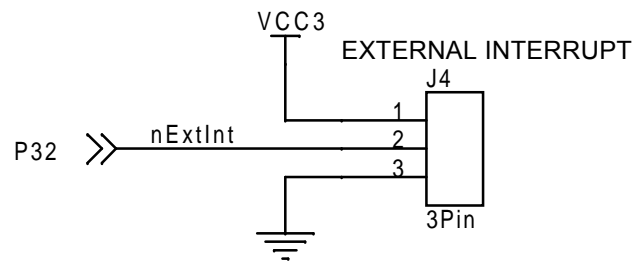
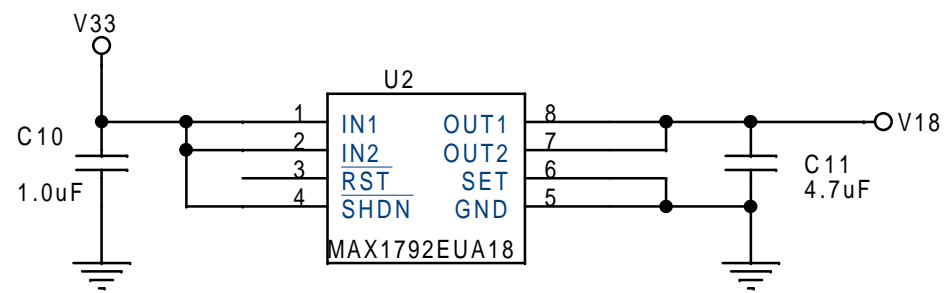
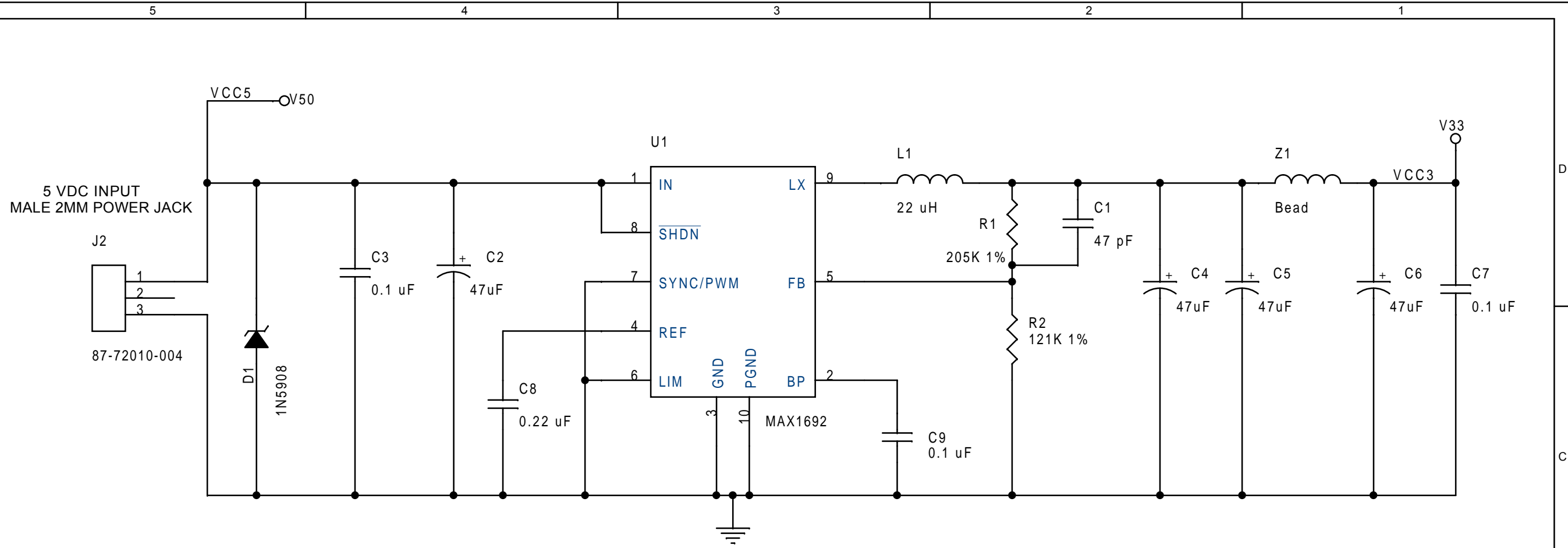

Title		
TINIm400 Socket Board: Power and Internals		
Size	Document Number	Rev
A	TINIs400	B
Date:	Monday, March 04, 2002	Sheet 2 of 7

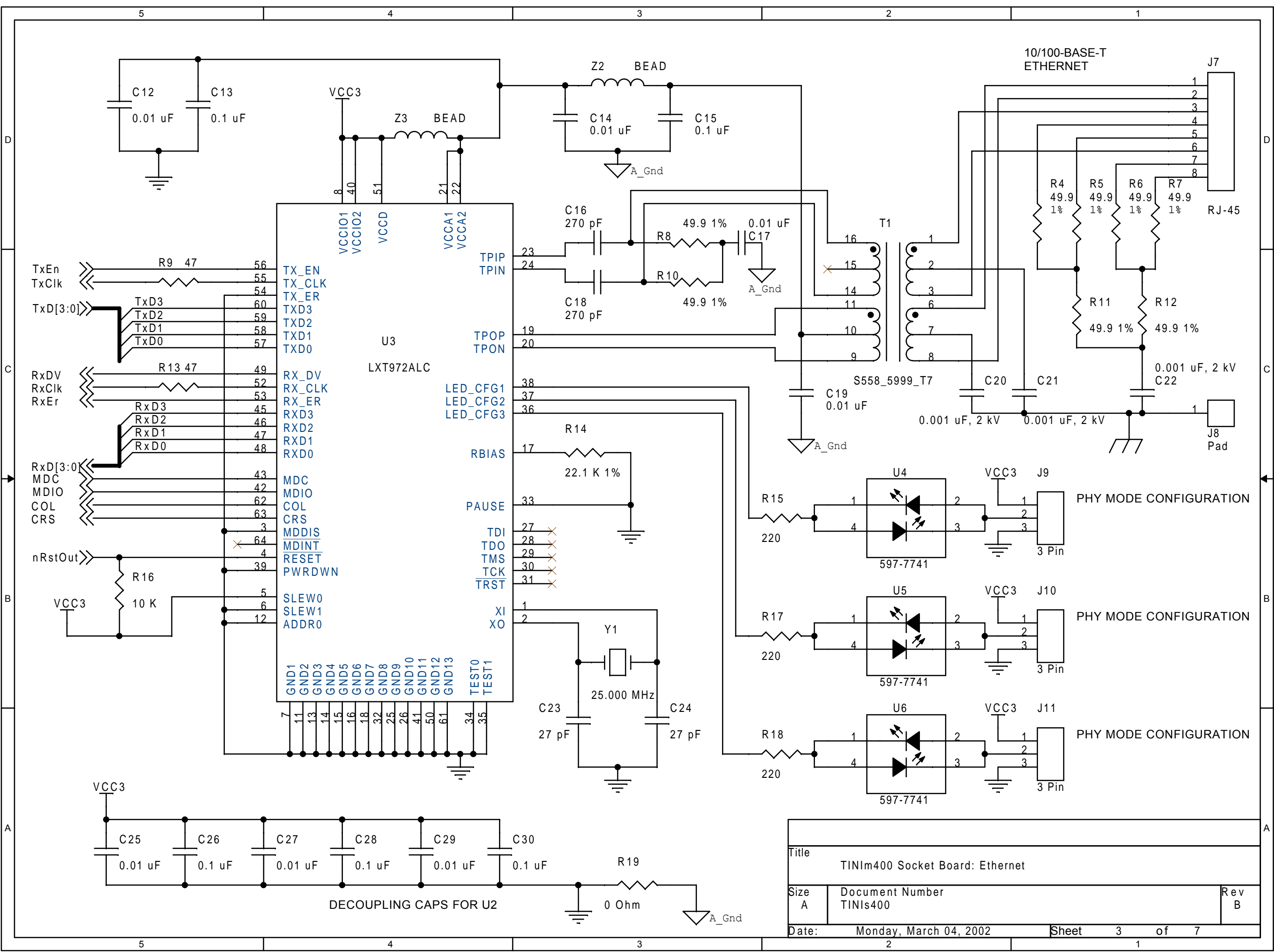

Title		
TINIm400 Socket Board: Ethernet		
Size	Document Number	Rev
A	TINIs400	B
Date:	Monday, March 04, 2002	Sheet 3 of 7





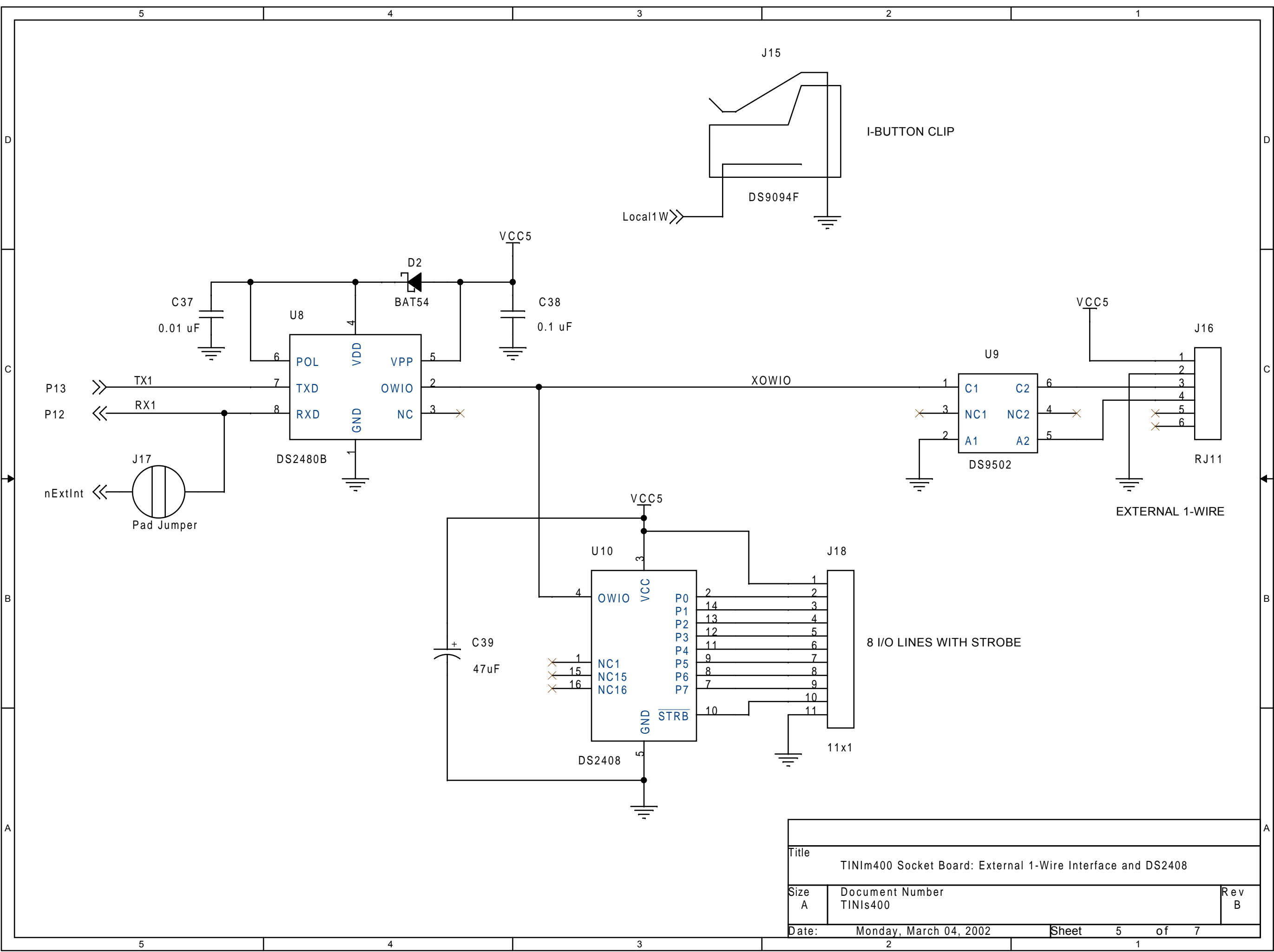

Title		
TINIm400 Socket Board: External 1-Wire Interface and DS2408		
Size	Document Number	Rev
A	TINIs400	B
Date:	Monday, March 04, 2002	Sheet 5 of 7

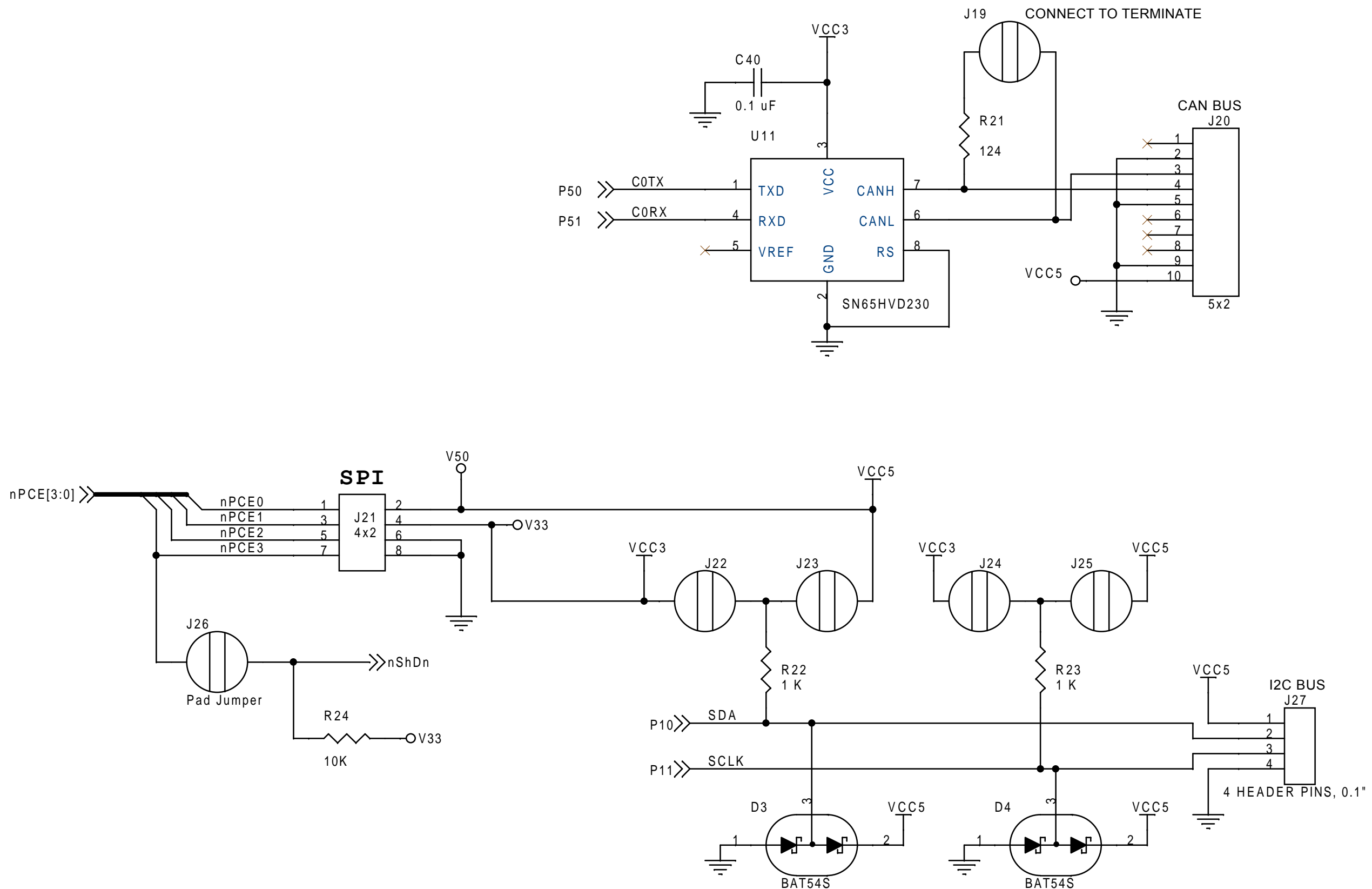

Title		
TINIm400 Socket Board: Other I/O		
Size	Document Number	Rev
A	TINIs400	B
Date:	Monday, March 04, 2002	Sheet 6 of 7

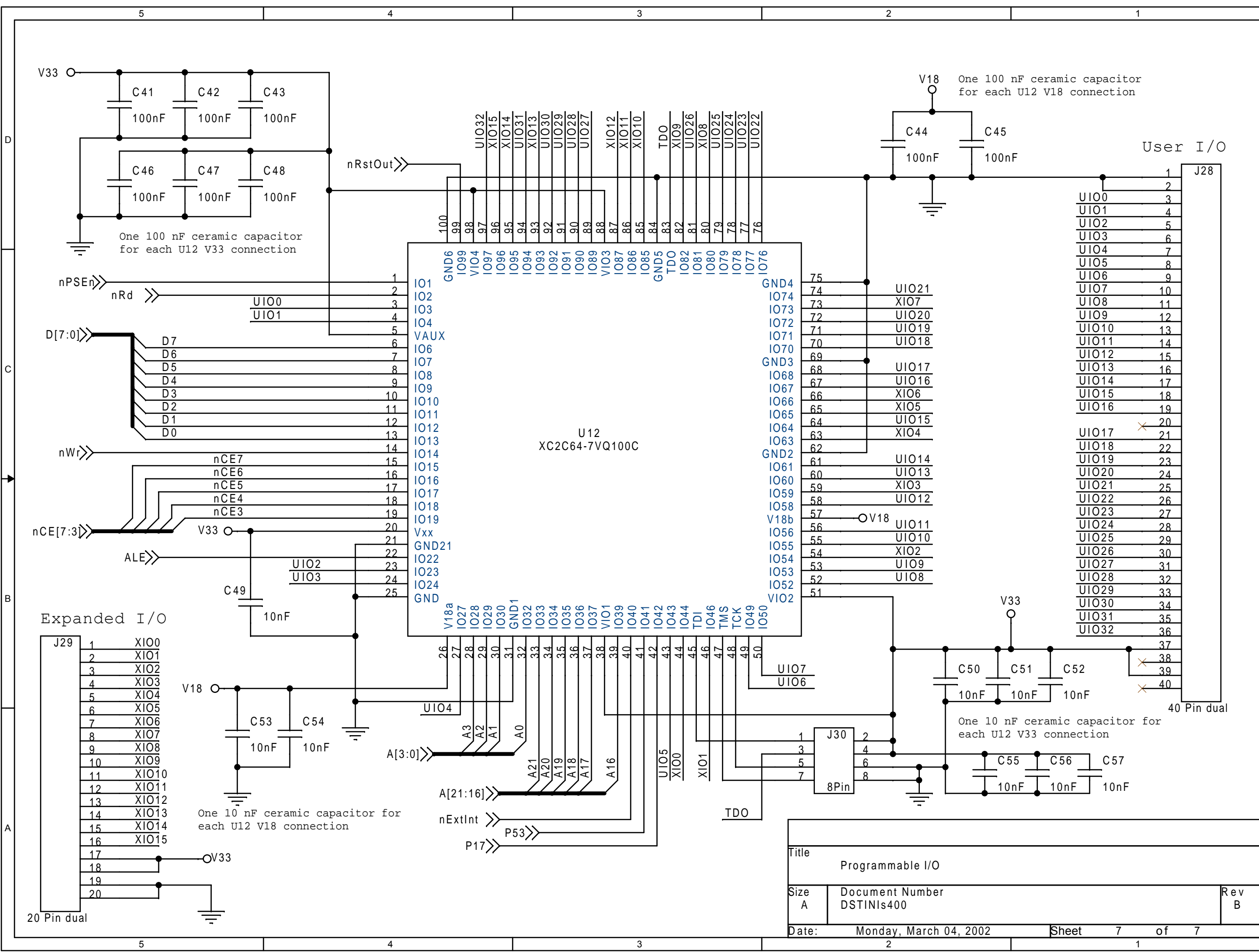

Title		
Programmable I/O		
Size	Document Number	Rev
A	DSTINIs400	B
Date:	Monday, March 04, 2002	Sheet 7 of 7