



ATAN Technology, Inc.

AT8989UP 9 port 10/100 Mb/s Single Chip Ethernet Switch Controller

Preliminary Data Sheet

Revision 1.1

Feb 2002



ATAN Technology, Inc.

Revision History

<i>Revision Date</i>	<i>Revision</i>	<i>Description</i>
<i>April/2001</i>	<i>0.1</i>	<i>First ATAN version</i>
<i>May/2001</i>	<i>0.2</i>	<i>Change RXP, RXN, TXP, TXN</i>
<i>July/2001</i>	<i>0.3</i>	<i>Change hardware Setting pin from A1 version 1. ENDC16 Swap with Dual Color setting EEPROM 0x12h bit 15.. 2. Aging hardware setting change to EEPROM 0x10h bit7. Port7 FX select change to TXER power on latch. 3. At Dual Speed mode each port support 100/10 Full/Half</i>
<i>Aug/2001</i>	<i>0.4</i>	<i>Separate Data Sheet from AT8989P</i>
<i>Sep/2001</i>	<i>0.9</i>	<i>1. Remove PHY Register from Data Sheet 2. Add AT8989UP 16 port application note in 3.5 3. Add EEPROM read explain in Dupcoll1 pin. 4. Modify LED display pin description.</i>
<i>Feb/2002</i>	<i>1.0</i>	<i>1. Add eeprom register 0x11h defaulted value as 0xff00h 2. Support By-pass Mode, register 0x11h bit5 3. Support Port-Base VLAN as default setting, Register 0x11h Bit5 4. Special address forwarding 01 80 C2 00 00 00 DA Forwarding 01 80 C2 00 00 01 DA Filtering 01 80 C2 00 00 02 ~ 01 80 C2 00 00 0F DA Forwarding 5. Support Maximum Packet size as Bypass mode : Tag packet 1522Byte, Untag packet 1522byte Non-bypass mode : Tag packet 1526byte, Untag packet 1522byte</i>
<i>Feb/2002</i>	<i>1.1</i>	<i>1. Remove "HubbingSwitch" mode description..</i>

Notice:

This document contains preliminary information on new products under development.

The specifications are subject to change without any further notice.

Please contact ATAN sales to ensure the updated specifications before finalizing your own design.

ATAN may make changes to specifications and product descriptions at any time without any notice.

Copyright © ATAN Technology, Inc. April 2000.

Third party brands and names are the property of their respective owners.



1. Introduction

1.1 General Descriptions

The AT8989UP is a high performance, low cost, highly integration (Controller, PHY and Memory) eight-port 10/100 Mbps TX/FX plus one 10/100/Expansion (1.6Gbps) port Ethernet switch controller with all ports supporting 10/100 Mbps Full/Half duplex and 1.6Gbps Expansion port support Full Duplex switch function. The AT8989UP is intended for applications to stand alone bridge for low cost SOHO market such as 8port plus one 100/10 FX or CPU and 16port Switch.

AT8989UP provides advanced function such as: **802.1p(Q.O.S.), 802.1q(VLAN), Port MAC address Locking, TP Auto MDIX , 25M Crystal & Extra ninth port(Expansion/MII/GPSI)** function to meet customer request on Switch demand.

The AT8989UP also supports Back-Pressure in Half-Duplex mode and 802.3x Flow Control Pause packet in Full-Duplex mode to prevent packet lost when buffer full. When Back Pressure is enabled, and there is no receive buffer available for the incoming packet, the AT8989UP will issue a JAM pattern on the receiving port in Half Duplex mode and transmit the 802.3x Pause packet back to receiving end in Full Duplex mode.

The built-in 1Mbit SRAM used for packet buffer and address learning table is divided into 256 bytes/block to achieve the optimized memory utilization through complicated link list on packets with various lengths.

AT8989UP also supports Port-Base, VLAN and IP TOS field checking for priority mapping. User can be easy to set as different priority mode in individual port, through a small low-cost micro controller to initialize or on-the-fly to configure. Each output port supports four queues in the way of fixed 8:4:2:1 fairness queuing to fit the bandwidth demand on various types of packet such as Voice, Video and data. 802.1Q, Tag/Untag, and up to 16 groups of VLAN also is supported. AT8989UP will learn the last 4 bits of VLAN ID.

An intelligent address recognition algorithm makes AT8989UP to recognize up to 2048 different MAC addresses and to enable filtering and forwarding at full wire speed.

Port MAC address Locking function is also supported by AT8989UP for customer to use on building Internet access to prevent multiple users share the same single port traffic.

1.2 Features

- ✓ Supports eight 10M/100M auto-detect Half/Full duplex switch ports with **TX/FX** interfaces and one universal port. This ninth port can be configured to be a GPSI interface, MII interface, and 1.6Gbps Expansion interface used as proprietary extension bus for cascading to wire-speed 16 port switch applications.
- ✓ Built-in 16Kx64 SRAM.
- ✓ Supports 2048 MAC addresses table.
- ✓ Supports four queues for QOS at fixed 8:4:2:1 rate.
- ✓ Supports Port-Based, 802.1p VLAN & IP TOS priority.
- ✓ Supports Store & Forward architecture and performs forwarding and filtering at non-blocking full wire speed.
- ✓ Supports buffer allocation with 256 bytes per block
- ✓ Supports Aging function Enable/Disable.
- ✓ Supports per port Single/Dual color mode with Power On auto diagnostic.
- ✓ Supports 802.3x Flow Control pause packet for Full Duplex in case buffer is full.
- ✓ Supports Back Pressure function for Half Duplex operation in case buffer is full.
- ✓ Supports packet length up to 1522 bytes.
- ✓ Broadcast Storming Filter function.
- ✓ One Trunk Port with 400M bandwidth formed by fixed two 10/100 ports.



ATAN Technology, Inc.

- ✓ Supports Port_base and 802.3Q VLAN. Up to 16 VLAN groups is supported by the last four bits of VLAN ID.
- ✓ Supports TP interface Auto MDIX function for auto TX/RX swap.
- ✓ Port7 could be strapping pin-setting as TX or FX mode.
- ✓ 25M Crystal only for whole system. Output 100M (Expansion), 50M (RMII), 25M (MII) & 10M (GPSI) clock for different applications.
- ✓ 208 QFP package with 2.25V/3.3V power supply.

1.3 Applications

AT8989UP in 208-pin PQFP:

- A. 8 10/100 MDIX TX/FX + FX/CPU Port.

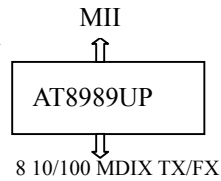

- B. 16-port Smart Switch with two AT8989UPs by 1.6Gbps Expansion bus,
- Any group of port-base VLAN, Trunking with console port.

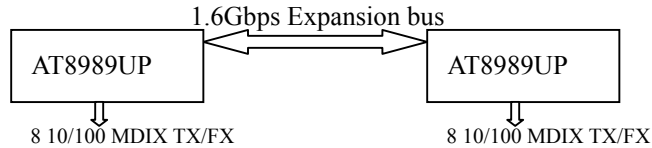



2. Pinout

2.1 8 TP/FX PORT+ Expansion/MII/GPSI

PORT 208 Pin Diagram

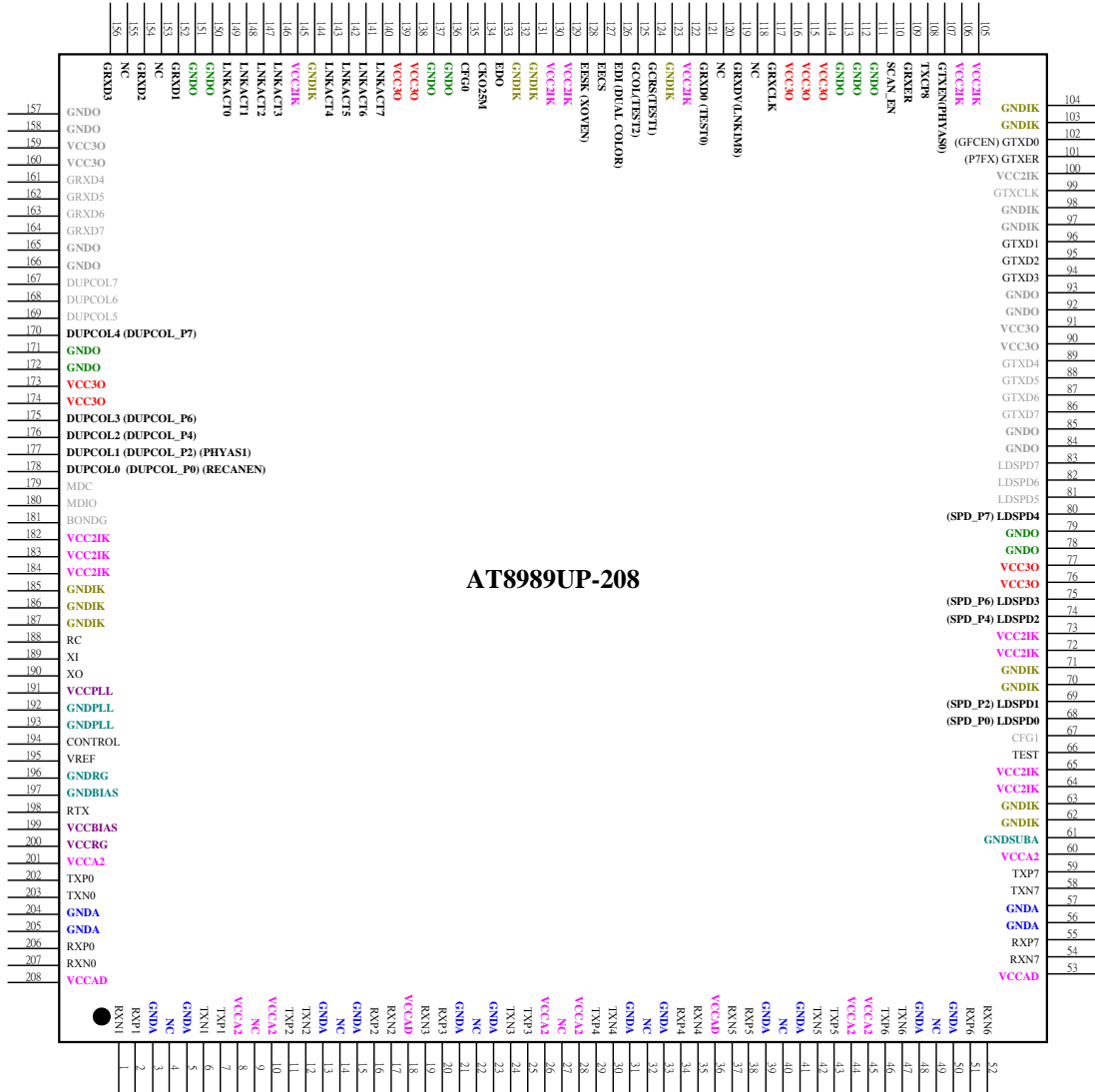



ATAN Technology, Inc.

2.2 Pin Description

AT8989UP-208 PINS(8TP/FX+Expan/MII/GPSI port)

Pin Type I: Input, O: Output, I/O: Bi-directional, OD: Open drain, SCHE: Schmitt Trigger
 PD : Internal Pull Down, PU : Internal Pull UP, 2.25V/3V: 2.25V with 3.3V tolerance

Defaulted configuration of AT8989UP :

Full-duplex, 100Mb/s, MDIX Off, auto-negotiation On, flow-control On, All TX mode, 8 TX+expansion_bus mode.

Pin #	Pin Name	Pin Type	Pin Description
<i>Chip configuration, 2pins</i>			
67, 135	CFG[1:0]	I, TTL	Configuration of Pin-out. CFG[1:0] Description 01 8 port and 1 GPSI interface 10 8 port and 1 MII interface 11 8 port and 1 Expansion bus interface for 16port application
<i>Twisted Pair Interface, 32 pins</i>			
206, 2, 16 20, 34, 38 51, 55	RXP[0:7]	I, Analog	Twisted Pair Receive Input Positive.
207, 1, 17 19, 35, 37 52, 54	RXN[0:7]	I, Analog	Twisted Pair Receive Input Negative.
202, 7, 11 25, 29, 43 46, 59	TXP[0:7]	O, Analog	Twisted Pair Transmit Output Positive.
203, 6, 12 24, 30, 42 47, 58	TXN[0:7]	O, Analog	Twisted Pair Transmit Output Negative.
<i>Ninth Port(MII, GPSI & Expansion) Interfaces, 26pins</i>			
102	GTXD[0] /GFCEN	I/O, 8mA PU	MII/GPSI/Expansion_bus transmit data 0 / Global Flow Control Enable. MII transmit data 0/Global Flow Control Enable. At power-on-reset, latched as Flow control setting “1” to enable flow-control (defaulted), “0” to disable flow-control. For output mode, acts as MII transmit data TXD or Expansion bus TXD0 Synchronous to the rising edge of TXCLK Internally Pull-up
94, 95, 96	GTXD[3:1]	O, 8mA	Expansion/MII Transmit Data bit 3~1 Synchronous to the rising edge of GTXCLK at Expansion mode.
86, 87, 88, 89	GTXD[7:4]	O 8mA	Expansion Port Transmit Data bit 7~4 Synchronous to the rising edge of GTXCLK.
101	GTXER /P7FX	I/O 8mA PD	GTXER(Expansion bus, MII transmit error)/P7FX Power-on-reset, Signals latched as TX (“0”), FX (“1”) mode at Port7. Internal pull down as Port7 TX mode.
156, 154, 152, 121	GRXD[3:0]	I PD	Expansion Port Receive Data bit 3 ~ 0 During power on reset, GRXD0 value will be latched by AT8989UP at the rising edge of RESETL for TSEL0. Internal pull down.



169, 170, 175, 176, 177, 178		8mA	“1” for half-duplex and “blinking” for collision indication “0” for full-duplex indication DUPCOL0 will be power on latch value as all port Auto Negotiation capability recommended value. Internal pull high as Auto Negotiation capability. Add pull down will disable all port Auto Negotiation capability.
177	DUPCOL[1]	O, 8mA	Duplex/Collision LED[1]. See “9thport interface” pin description for details.
178	DUPCOL0/ANEN	I/O, 8mA PU	Duplex/Collision LED[0] / AutoNegotiation Enable. On power-on-reset, latched as Auto Negotiation capability for all ports. “1” to enable AutoNegotiation (defaulted by pulled up internally), “0” to disable AutoNegotiation.
83, 82, 81 80, 75, 74 69, 68	LDSPD[7:0]	O, 16mA	Speed LED[7:0]. Used to indicate corresponding port’s speed status. “0” for 100Mb/s, “1” for 10Mb/s
EEPROM/Management Interface, 6 pins			
133	EEDO	I, TTL, PU	EEPROM Data Output. Serial data input from EEPROM. This pin is internal pull-up.
127	EECS	O, 4mA, PD	EEPROM Chip Select. This pin is active high chip enable for EEPROM. When RESETL is low, it will be Tri-state. This pin is internal pull-down.
128	EECK/ XOVEN	I/O, 4mA PD	Serial Clock. This pin is clock source for EEPROM. When RESETL is low, it will be tri-state. This pin is internally pull-down. XOVEN. On power-on-reset, latched as P7~0 Auto MDIX enable or not. “1” to disable MDIX (defaulted), “0” to enable MDIX. Suggest externally pull up to enable MDIX for all ports.
126	EEDI/Dual Color	O, 4mA PD	EEPROM Serial Data Input. This pin is output for serial data transfer. When RESETL is low, it will be tri-state. This pin is internal pull-down. Dual Color. On power-on-reset, latched as Dual Color mode or not. “0” to set Single color mode for LED. “1” to set Dual Color mode for LED.
180	MDIO	I/O, 8mA	Management Data. This pin is in-out to PHY. When RESETL is low, this pin will be tri-state.
179	MDC	O, 8mA	Management Data Clock. This pin output 1MHz clock to drive PHY and access corresponding speed and duplex data through MDIO.
MISC., 11 pins			
134	CKO25M	O, 8mA	10M Clock Output For 1M8 port configuration, 50M output for DSHUB slave and 25M Clock Output for others.
194	Control	O	FET Control Signal. The pin is used to control FET for 3.3V to 2.5V Regulator.
198	RTX	Analog	TX Resistor.
195	VREF	Analog	Analog Reference Voltage.
188	RC	I, SCHE	RC Input For Power On reset.
189	XI	I, Analog	25M Crystal Input. 25M Crystal Input. Variation is limited to +/- 50ppm.
190	XO	O, Analog	25M Crystal Output. When connected to oscillator, this pin should left unconnected.
181	BONDG	I, TTL	Must connect to Ground.
Power/Ground., 98 pins			



ATAN Technology, Inc.

3, 5, 13, 15, 21, 23, 31, 33, 39, 41, 48, 50, 56, 57, 204, 205	GNDA		Ground Used by AD Block.
8, 10, 26, 28, 44, 45, 60, 201	VCCA2		2.25V, Power Used by TX Line Driver.
18, 36, 53, 208	VCCAD		3.3V, Power Used by AD Block.
61	GNDSUBA		Ground Used by Analog Substrate
197	GNDBIAS		Ground Used by Bias Block
199	VCCBIAS		3.3V, Power Used by Bias Block.
192, 193	GNDPLL		Ground used by PLL
191	VCCPLL		2.25V, Power used by PLL
62, 63, 70, 71, 97, 98, 103, 104, 123, 131, 132, 144 185, 186, 187	GNDIK		Ground Used by Digital Core
64, 65, 72, 73, 100, 105, 106, 122, 129 130, 145, 182 183, 184	VCCIK		2.25V, Power Used by Digital Core
78, 79, 84, 85, 92, 93, 111, 112, 113 136, 137, 150 151, 157, 158 165, 166, 171 172	GND0		Ground Used by Digital Pad
76, 77, 90, 91, 114, 115 116, 138, 139 159, 160, 173, 174	VCC30		3.3V, Power Used by Digital Pad.
200	VCCRG		3.3V, Power used of Regulator
196	GNDRG		Ground used of Regulator
110	GND	I, TTL	Scan Enable. This pin will be used as the scan enable input for testing. Connect to GND at normal application.
NC pin., 12 pins			
4, 9, 14, 22, 27, 32, 40, 49, 118 120, 153, 155	NC		Not Connect.



3. Description

3.1 Functional Descriptions

The AT8989UP integrates eight 100Base-X physical sub-layer (PHY), 100Base-TX physical medium dependent (PMD) transceivers, eight complete 10Base-T modules, 8 port 100/10 switch controller and one 1.6G MAC and memory into a single chip for both 10 Mbps, 100 Mbps Ethernet switch operation. It also supports 100Base-FX operation through external fiber-optic transceivers. The device is capable of operating in either Full Duplex mode or Half-Duplex mode in either 10 Mbps or 100 Mbps operation. 1.6G Expansion port only supports Full Duplex. Operational modes can be selected by hardware configuration pins, software settings of management registers, or determined by the on-chip auto negotiation logic.

The AT8989UP consists of three major blocks:

- 10/100M PHY Block
- Switch Controller Block
- Built-in 16Kx64 SSRAM

3.2 10/100M PHY Block

The 100Base-X section of the device implements the following functional blocks :

- 100Base-X physical coding sub-layer (PCS)
- 100Base-X physical medium attachment (PMA)
- Twisted-pair transceiver (PMD)

The 100Base-X and 10Base-T sections share the following functional blocks :

- Clock synthesizer module
- MII Registers
- IEEE 802.3u auto negotiation

The interfaces used for communication between PHY block and switch core is MII interface.

Auto MDIX function is supported in this block. This function can be Enable/Disable by hardware pin.

3.2.1 100Base-X Module

The AT8989UP implements 100Base-X compliant PCS and PMA and 100Base-TX compliant TP-PMD as illustrated in Figure 2. Bypass options for each of the major functional blocks within the 100Base-X PCS provides flexibility for various applications. 100 Mbps PHY loop back is included for diagnostic purpose.

3.2.2 100Base-X Receiver

The 100Base-X receiver consists of functional blocks required to recover and condition the 125 Mbps receive data stream. The AT8989UP implements the 100Base-X receiving state machine diagram as given in ANSI/IEEE Standard 802.3u, Clause 24. The 125 Mbps receive data stream may originate from the on-chip twisted-pair transceiver in a 100Base-TX application. Alternatively, the receive data stream may be generated by an external optical receiver as in a 100Base-FX application.

The receiver block consists of the following functional sub-blocks :



ATAN Technology, Inc.

- A/D Converter
- Adaptive Equalizer and timing recovery module
- NRZI/NRZ and serial/parallel decoder
- De-scrambler
- Symbol alignment block
- Symbol Decoder
- Collision Detect Block
- Carrier sense Block
- Stream decoder block

3.2.2.1 A/D Converter

High performance A/D converter with 125M sampling rate converts signals received on RXP/RXN pins to 6 bits data streams; besides it possess auto-gain-control capability that will further improve receive performance especially under long cable or harsh detrimental signal integrity. Due to high pass characteristic on transformer, built in base-line-wander correcting circuit will cancel it out and restore its DC level.

3.2.2.2 Adaptive Equalizer and timing Recovery Module

All digital design is especial immune from noise environments and achieves better correlation between production and system testing. Baud rate Adaptive Equalizer/Timing Recovery compensates line loss induced from twisted pair and tracks far end clock at 125M samples per second. Adaptive Equalizer implemented with Feed forward and Decision Feedback techniques meet the requirement of BER less than 10⁻¹² for transmission on CAT5 twisted pair cable ranging from 0 to 120 meters.

3.2.2.3 NRZI/NRZ and Serial/Parallel Decoder

The recovered data is converted from NRZI to NRZ. The data is not necessarily aligned to 4B/5B code group's boundary.

3.2.2.4 Data De-scrambling

The de-scrambler acquires synchronization with the data stream by recognizing idle bursts of 40 or more bits and locking its deciphering Linear Feedback Shift Register (LFSR) to the state of the scrambling LFSR. Upon achieving synchronization, the incoming data is XORed by the deciphering LFSR and de-scrambled.

In order to maintain synchronization, the de-scrambler continuously monitors the validity of the unscrambled data that it generates. To ensure this, a link state monitor and a hold timer are used to constantly monitor the synchronization status. Upon synchronization of the de-scrambler the hold timer starts a 722 us countdown. Upon detection of sufficient idle symbols within the 722 us period, the hold timer will reset and begin a new countdown. This monitoring operation will continue indefinitely given a properly operating network connection with good signal integrity. If the link state monitor does not recognize sufficient unscrambled idle symbols within 722 us period, the de-scrambler will be forced out of the current state of synchronization and reset in order to re-acquire synchronization.

3.2.2.5 Symbol Alignment

The symbol alignment circuit in the AT8989UP determines code word alignment by recognizing the /J/K delimiter pair. This circuit operates on unaligned data from the de-scrambler. Once the /J/K symbol pair (11000 10001) is detected, subsequent data is aligned on a fixed boundary.



3.2.2.6 Symbol Decoding

The symbol decoder functions as a look-up table that translates incoming 5B symbols into 4B nibbles as shown in Table 1. The symbol decoder first detects the /J/K symbol pair preceded by idle symbols and replaces the symbol with MAC preamble. All subsequent 5B symbols are converted to the corresponding 4B nibbles for the duration of the entire packet. This conversion ceases upon the detection of the /T/R symbol pair denoting the end of stream delimiter (ESD). The translated data is presented on the internal RXD[3:0] signal lines with RXD[0] represents the least significant bit of the translated nibble.

3.2.2.7 Valid Data Signal

The valid data signal (RXDV) indicates that recovered and decoded nibbles are being presented on the internal RXD[3:0] synchronous to receive clock, RXCLK. RXDV is asserted when the first nibble of translated /J/K is ready for transfer over the internal MII. It remains active until either the /T/R delimiter is recognized, link test indicates failure, or no signal is detected. On any of these conditions, RXDV is de-asserted.

3.2.2.8 Receive Errors

The RXER signal is used to communicate receiver error conditions. While the receiver is in a state of holding RXDV asserted, the RXER will be asserted for each code word that does not map to a valid code-group.

3.2.2.9 100Base-X Link Monitor

The 100Base-X link monitor function allows the receiver to ensure that reliable data is being received. Without reliable data reception, the link monitor will halt both transmit and receive operations until such time that a valid link is detected.

The AT8989UP performs the link integrity test as outlined in IEEE 100Base-X (Clause 24) link monitor state diagram.

The link status is multiplexed with 10 Mbps link status to form the reportable link status bit in serial management register 1h, and driven to the LNKACT pin.

When persistent signal energy is detected on the network, the logic moves into a Link-Ready state after approximately 500 us, and waits for an enable from the auto negotiation module. When receive, the link-up state is entered, and the transmission and reception logic blocks become active. Should auto negotiation be disabled, the link integrity logic moves immediately to the link-up state after entering the link-ready state.

3.2.2.10 Carrier Sense

Carrier sense (CRS) for 100 Mbps operation is asserted upon the detection of two noncontiguous zeros occurring within any 10-bit boundary of the received data stream.

The carrier sense function is independent of symbol alignment. In switch mode, CRS is asserted during either packet transmission or reception. For repeater mode, CRS is asserted only during packet reception. When the idle symbol pair is detected in the received data stream, CRS is de-asserted. In repeater mode, CRS is only asserted due to receive activity. CRS is intended to encapsulate RXDV.

3.2.2.11 Bad SSD Detection

A bad start of stream delimiter (Bad SSD) is an error condition that occurs in the 100Base-X receiver if carrier is detected (CRS asserted) and a valid /J/K set of code-group (SSD) is not received.

If this condition is detected, then the AT8989UP will assert RXER and present RXD[3:0] = 1110 to the internal MII for the



cycles that correspond to received 5B code-groups until at least two idle code-groups are detected. Once at least two idle code groups are detected, RXER and CRS become de-asserted.

3.2.2.12 Far-End Fault

Auto negotiation provides a mechanism for transferring information from the Local Station to the link Partner that a remote fault has occurred for 100Base-TX. As auto negotiation is not currently specified for operation over fiber, the far end fault indication function (FEFI) provides this capability for 100Base-FX applications.

A remote fault is an error in the link that one station can detect while the other cannot. An example of this is a disconnected wire at a station's transmitter. This station will be receiving valid data and detect that the link is good via the link integrity monitor, but will not be able to detect that its transmission is not propagating to the other station.

A 100Base-FX station that detects such a remote fault may modify its transmitted idle stream from all ones to a group of 84 ones followed by a single 0. This is referred to as the FEFI idle pattern.

3.2.3 100Base-TX Transceiver

AT8989UP implements a TP-PMD compliant transceiver for 100Base-TX operation. The differential transmit driver is shared by the 10Base-T and 100Base-TX subsystems. This arrangement results in one device that uses the same external magnetic for both the 10Base-T and the 100Base-TX transmission with simple RC component connections. The individually wave-shaped 10Base-T and 100Base-TX transmit signals are multiplexed in the transmission output driver selection.

3.2.3.1 Transmit Drivers

The AT8989UP 100Base-TX transmission driver implements MLT-3 translation and wave-shaping functions. The rise/fall time of the output signal is closely controlled to conform to the target range specified in the ANSI TP-PMD standard.

3.2.3.2 Twisted-Pair Receiver

For 100Base-TX operation, the incoming signal is detected by the on-chip twisted-pair receiver that consists of a differential line receiver, an adaptive equalizer and a base-line wander compensation circuits.

The AT8989UP uses an adaptive equalizer that changes filter frequency response in accordance with cable length. The cable length is estimated based on the incoming signal strength. The equalizer tunes itself automatically for any cable length to compensate for the amplitude and phase distortions incurred from the cable.

3.2.4 10Base-T Module

The 10Base-T Transceiver Module is IEEE 802.3 compliant. It includes the receiver, transmitter, collision, heartbeat, loop back, jabber, wave shaper, and link integrity functions, as defined in the standard. Figure 3 provides an overview for the 10Base-T module.

The AT8989UP 10Base-T module is comprised of the following functional blocks:

- √ Manchester encoder and decoder
- √ Collision detector
- √ Link test function
- √ Transmit driver and receiver
- √ Serial and parallel interface
- √ Jabber and SQE test functions



ATAN Technology, Inc.

√ Polarity detection and correction

3.2.4.1 Operation Modes

The AT8989UP 10Base-T module is capable of operating in either half-duplex mode or full-duplex mode. In half-duplex mode, the AT8989UP functions as an IEEE 802.3 compliant transceiver with fully integrated filtering. The COL signal is asserted during collisions or jabber events, and the CRS signal is asserted during transmit and receive. In full duplex mode the AT8989UP can simultaneously transmit and receive data.

3.2.4.2 Manchester Encoder/Decoder

Data encoding and transmission begins when the transmission enable input (TXEN) goes high and continues as long as the transceiver is in good link state. Transmission ends when the transmission enable input goes low. The last transition occurs at the center of the bit cell if the last bit is a 1, or at the boundary of the bit cell if the last bit is 0.

Decoding is accomplished by a differential input receiver circuit and a phase-locked loop that separate the Manchester-encoded data stream into clock signals and NRZ data. The decoder detects the end of a frame when no more mid bit transitions are detected. Within one and half bit times after the last bit, carrier sense is de-asserted.

3.2.4.3 Transmit Driver and Receiver

The AT8989UP integrates all the required signal conditioning functions in its 10Base-T block such that external filters are not required. Only one isolation transformer and impedance matching resistors are needed for the 10Base-T transmit and receive interface. The internal transmit filtering ensures that all the harmonics in the transmission signal are attenuated properly.

3.2.4.4 Smart Squelch

The smart squelch circuit is responsible for determining when valid data is present on the differential receiver. The AT8989UP implements an intelligent receive squelch on the RXP/RXN differential inputs to ensure that impulse noise on the receive inputs will not be mistaken for a valid signal. The squelch circuitry employs a combination of amplitude and timing measurements (as specified in the IEEE 802.3 10Base-T standard) to determine the validity of data on the twisted-pair inputs.

The signal at the start of the packet is checked by the analog squelch circuit and any pulses not exceeding the squelch level (either positive or negative, depending upon polarity) will be rejected. Once this first squelch level is overcome correctly, the opposite squelch level must then be exceeded within 150ns. Finally, the signal must exceed the original squelch level within an additional 150ns to ensure that the input waveform will not be rejected.

Only after all these conditions have been satisfied will a control signal be generated to indicate to the remainder of the circuitry that valid data is present.

Valid data is considered to be present until the squelch level has not been generated for a time longer than 200 ns, indicating end of packet. Once good data has been detected, the squelch levels are reduced to minimize the effect of noise, causing premature end-of-packet detection. The receive squelch threshold level can be lowered for use in longer cable applications. This is achieved by setting bit 10 of register address 11h.

3.2.5 Carrier Sense

Carrier Sense (CRS) is asserted due to receive activity once valid data is detected via the smart squelch function. For 10 Mbps half duplex operation, CRS is asserted during either packet transmission or reception. For 10 Mbps full duplex and



ATAN Technology, Inc.

repeater mode operations, the CRS is asserted only due to receive activity.

3.2.6 Collision Detection

The RMII does not have a collision pin. Collision is detected internal to the MAC, which is generated by an AND function of TXEN and CRS derived from CRSDV. CRSDV cannot be directly ANDed with TXEN, because CRSDV may toggle at the end of a frame to provide separation between CRS and RXDV. The internal MII will still generate the COL signal, but this information is not passed to the AMC via the RMII.

3.2.7 Jabber Function

The jabber function monitors the AT8989UP output and disables the transmitter if it attempts to transmit a longer than legal sized packet. If TXEN is high for greater than 24ms, the 10Base-T transmitter will be disabled. Once disabled by the jabber function, the transmitter stays disabled for the entire time that the TXEN signal is asserted. This signal has to be de-asserted for approximately 256 ms (The un-jab time) before the jabber function re-enables the transmit outputs. The jabber function can be disabled by programming bit 4 of register address 10h to high.

3.2.8 Link Test Function

A link pulse is used to check the integrity of the connection with the remote end. If valid link pulses are not received, the link detector disables the 10Base-T twisted-pair transmitter, receiver, and collision detection functions.

The link pulse generator produces pulses as defined in IEEE 802.3 10Base-T standard. Each link pulse is nominally 100ns in duration and is transmitted every 16 ms, in the absence of transmit data.

3.2.9 Automatic Link Polarity Detection

AT8989UP's 10Base-T transceiver module incorporates an "automatic link polarity detection circuit". The inverted polarity is determined when seven consecutive link pulses of inverted polarity or three consecutive packets are received with inverted end-of-packet pulses. If the input polarity is reversed, the error condition will be automatically corrected and reported in bit 5 of register 10h.

3.2.10 Clock Synthesizer

The AT8989UP implements a clock synthesizer that generates all the reference clocks needed from a single external frequency source. The clock source must be a TTL level signal at 25 MHz +/- 50ppm

3.3 Auto Negotiation

The Auto Negotiation function provides a mechanism for exchanging configuration information between two ends of a link segment and automatically selecting the highest performance mode of operation supported by both devices. Fast Link Pulse (FLP) Bursts provide the signaling used to communicate auto negotiation abilities between two devices at each end of a link segment. For further detail regarding auto negotiation, refer to Clause 28 of the IEEE 802.3u specification. The AT8989UP supports four different Ethernet protocols, so the inclusion of auto negotiation ensures that the highest performance protocol will be selected based on the ability of the link partner.

Highest priority relative to the following list.

1. 100Base-TX full duplex (highest priority)
2. 100Base-TX half duplex
3. 10Base-T full duplex



4. 10Base-T half duplex (lowest priority)

3.4 Switch Functional Description

The AT8989UP uses a “store & forward” switching approach for the following reason:

Store & forward switches allow switching between different speed media (e.g. 10BaseX and 100BaseX). Such switches require the large elastic buffer especially bridging between a server on a 100Mbps network and clients on a 10Mbps segment.

Store & forward switches improve overall network performance by acting as a “network cache”

Store & forward switches prevent the forwarding of corrupted packets by the frame check sequence (FCS) before forwarding to the destination port.

3.4.1 Basic Operation

The AT8989UP receives incoming packets from one of its ports, searches in the Address Table for the Destination MAC Address and then forwards the packet to the other port within same VLAN group, if appropriate. If the destination address is not found in the address table, the AT8989UP treats the packet as a broadcast packet and forwards the packet to the other ports which in same VLAN group.

The AT8989UP automatically learns the port number of attached network devices by examining the Source MAC Address of all incoming packets at wire speed. If the Source Address is not found in the Address Table, the device adds it to the table.

3.4.1.1 Address Learning

The AT8989UP uses a hash algorithm to learn the MAC address and can learn up to 2K MAC addresses. Address is stored in the Address Table. The AT8989UP searches for the Source Address (SA) of an incoming packet in the Address Table and acts as below:

If the SA was not found in the Address Table (a new address), the AT8989UP waits until the end of the packet (non-error packet) and updates the Address Table. If the SA was found in the Address Table, then aging value of each corresponding entry will be reset to 0.

When the DA is PAUSE command, then the learning process will be disabled automatically by AT8989UP.

3.4.1.2 Address Recognition and Packet Forwarding

The AT8989UP forwards the incoming packets between bridged ports according to the Destination Address (DA) as below. All the packet forwarding will check VLAN first. Forwarding port must same VLAN with source port.

(1) If the DA is an UNICAST address and the address was found in the Address Table, the AT8989UP will check the port number and acts as follows:

- ♦ If the port number is equal to the port on which the packet was received, the packet is discarded.
- ♦ If the port number is different, the packet is forwarded across the bridge.

(2) If the DA is an UNICAST address and the address was not found, the AT8989UP treats it as a multicast packet and forwards across the bridge.

(3) If the DA is a Multicast address, the packet is forwarded across the bridge.

(4) If the DA is PAUSE Command (01-80-C2-00-00-01), then this packet will be dropped by AT8989UP. AT8989UP can issue and learn PAUSE command.

(5) AT8989UP will forward the packet with DA of (01-80-C2-00-00-00), filter out the packet with DA of



ATAN Technology, Inc.

(01-80-C2-00-00-01), and forward the packet with DA of (01-80-C2-00-00-02 ~ 01-80-C2-00-00-0F)

3.4.1.3 Address Aging

Address aging is supported for topology changes such as an address moving from one port to the other. When this happens, the AT8989UP internally has a 300 seconds timer will aged out (remove) the address from the address table. Aging function can enable/disable by user. Normally, disabling aging function is for security purpose.

3.4.1.4 Buffers and Queues

The AT8989UP incorporates nine transmit queues and receive buffer area for the nine ETHERNET ports. The receive buffers as well as the transmitted queues are located within the AT8989UP along with the switch fabric. The buffers are divided into 448 blocks of 256 bytes each. The queues of each port are managed according to each port's read/write pointer.

Input buffers and output queues are maintained through ATAN proprietary patent pending UNIQUE (Universal Queue management) scheme.

3.4.1.5 Back off Algorithm

The AT8989UP implements the truncated exponential back off algorithm compliant to the 802.3 CSMA-CD standard. AT8989UP will restart the back off algorithm by choosing 0-9 collision counts. The AT8989UP resets the collision counter after 16 consecutive retransmit trials.

3.4.1.6 Inter-Packet Gap (IPG)

IPG is the idle time between any two successive packets from the same port. The typical number is 96 bits time. The value is 9.6us for 10Mbps ETHERNET, 960ns for 100Mbps fast ETHERNET and 96ns for 1000M. AT8989UP provide option of 92 bit gap in EEPROM to prevent packet lost when turn off Flow Control and clock P.P.M. value difference.

3.4.1.7 Illegal Frames

The AT8989UP will discard all illegal frames such as runt packet (less than 64 bytes), oversize packet (greater than 1518 or 1522 bytes) and bad CRC. Dribbling packing with good CRC value will accept by AT8989UP.

3.4.1.8 Half Duplex Flow Control

Back Pressure function is supported for half-duplex operation. When the AT8989UP cannot allocate a receive buffer for an incoming packet (buffer full), the device will transmit a jam pattern on the port, thus forcing a collision. Back Pressure is enabled by the BPEN set during RESET asserting. An ATAN proprietary algorithm is implemented inside the AT8989UP to prevent back pressure function cause HUB partitioned under heavy traffic environment and reduce the packet lost rate to increase the whole system performance.

3.4.1.9 Full Duplex Flow Control

When full duplex port run out of its receive buffer, a PAUSE packet command will be issued by AT8989UP to notice the packet sender to pause transmission. This frame based flow control is totally compliant to IEEE 802.3x. AT8989UP can issue or receive pause packet.



3.4.1.10 Broadcast Storm filter

If Broadcast Storming filter is enable, the broadcast packets over the rising threshold within 50 ms will be discarded by the threshold setting. See EEPROM Reg.10h.

Broadcast storm mode after initial:

- Time interval : 50ms

the max. packet number = 7490 in 100Base, 749 in 10Base

Per Port Rising Threshold				
	00	01	10	11
All 100TX	Disable	10%	20%	40%
Not All 100TX	Disable	1%	2%	4%

Per Port Falling Threshold				
	00	01	10	11
All 100TX	Disable	5%	10%	20%
Not All 100TX	Disable	0.5%	1%	2%

3.4.2 Auto TP MDIX function

The traditional method to connect switches and NIC cards is to use one-by-one TP cables. If Switch connects other devices such as another Switch, it must be done by two ways. First is to use Cross-Over TP cable. Second is to use extra RJ45 connector which crossovers internal TX+- and RX+- signal, so-called Uplink port on the front panel of traditional network equipments. Those need extra cost and are not good solution for home-users. AT8989P provides Auto MDIX function which can adjust TX+- and RX+- at correct pin. User can use one-by-one cables between AT8989P and other devices on every port. This function can be Enabled/Disabled by hardware pin or EEPROM option.

3.4.3 Port Locking

Port locking function will provide customer simple way to limit per port user number to one. If this function is turn on then AT8989UP will lock first MAC address in learning table. After this MAC address locking will never age out except Reset signal. Another MAC address which not same as locking one will be dropped. AT8989UP provide one MAC address per port. This function is per port setting. When turn on Port Locking function, recommend customer turn off aging function.

3.4.4 Trunk Port

AT8989UP supports one Trunk port formed by two 10/100 ports to achieve 400Mbps bandwidth. Those two ports are port 6, and port 7, the last two ports. The trunk function supports Fault tolerance in which the packet will be routed into the other port when either port 6 or port 7 cable disconnect/link fail. Trunk function can set by hardware or EEPROM. EEPROM setting has a higher priority than strapping-pin setting.

3.4.5 VLAN setting & Tag/Untag & port_based VLAN

AT8989UP supports bypass mode and untagged port as default setting while the chip is power-on. Thus, every packet with or without tag will be forwarding to the destination port without any modification by AT8989UP. Meanwhile port-base VLAN could be enabled according to the PVID value (4bits to map 16 groups written at register 13 to register 22) of the configuration content of each port.

AT8989UP supports 16 VLAN groups. AT8989UP will recognize the last four bits of total twelve VLAN IDs. If user need to use this function, two EEPROM registers are needed to be programmed first :

* Port VID number at EEPROM register 0x1~0x9 bit 13~10: AT8989UP will check the coming packets and will add



ATAN Technology, Inc.

the four bytes VLAN tag to the non-VLAN packets. The LSB of VID will be inserted by the four-bit value.

* VLAN Group Mapping Register. EEPROM register 013h~022h defines VLAN grouping value. User uses these registers to define VLAN groups.

User can define each port as Tag port or Untag port by register Bit 4. The operation of the communication of packets between Tag port and Untag port can be explained by the following examples:

Example1: A port receives Untag packets and sends to an Untag port.

AT8989UP will check the port VLAN ID first, then check VLAN group register. If destination port same VLAN as receiving port then this packet will forward to destination port without any change. If destination port not same VLAN as receiving port then this packet will be dropped.

Example2: A port receives Untag packets and sends to a Tag port.

AT8989UP will check the port VLAN ID first then check VLAN group register. If destination port same VLAN as receiving port then this packet will forward to destination port with four byte VLAN Tag and new CRC. If destination port not same VLAN as receiving port then this packet will be dropped.

Example3: Port receives Tag packet and send to an Untag port.

AT8989UP will check the packet VLAN ID first then check VLAN group register. If destination port same VLAN as receiving port then this packet will forward to destination port after remove four bytes with new CRC error. If destination port not same VLAN as receiving port then this packet will be dropped.

Example4: Port receives Tag packet and send to a Tag port.

AT8989UP will check the packet VLAN ID first then check VLAN group register. If destination port same VLAN as receiving port then this packet will forward to destination port after remove without any change. If destination port not same VLAN as receiving port then this packet will be dropped.

3.4.6 Priority Setting

Switch devices not only handle with data packets but also provide services of multimedia data. AT8989UP provides four priority queues on each port at fixed 8:4:2:1 rate. This priority function can set three ways as below:

* By Port Base: Set specific port at specific queue. AT8989UP only check the port priority and not check VLAN and TOS.

* By VLAN first: AT8989UP check VLAN three priority bit first then TOS priority bits.

* By IP TOS first: AT8989UP check IP TOS three priority bit first then VLAN three priority bits.

User can set drop low-priority queue (Q0, Q1 & Q2) when buffer full. This function is optional.

3.4.7 Buffer Management

AT8989UP has embedded 1M bit SSRAM for the cost-sensitive market. Since most of packets have length of 256bytes less at real network environment, AT8989UP is designed as 256bytes/block of internal memory. The packets with less 256 bytes length will occupy one block. And AT8989UP will link 2~6 blocks to store the packets of more than 256bytes. This buffer management will provide a better memory utilization on the limited memory size and get a better performance on the real network application.

3.4.8 LED Display

Three LEDs per port are provided by AT8989UP. Link/Act, Duplex/Col & Speed are three LED display of AT8989UP. **Dual color LED mode** is also supported by AT8989UP. For the easy production purpose AT8989UP will send test signals to each LED one by one at power-on-reset. EEPROM register 0x12h defines the LED configuration table.

AT8989UP/GP LED is active Low signal. Dupcol0 & Dupcol1 will check the pin-setting at Reset time. If the pin-setting add a pull high resistor then LEDs will active Low. If the pin-setting add a pull down resistor, LEDs will drive high.

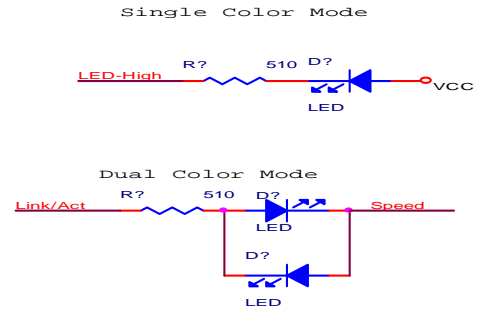

3.5 AT8989UP 16 Port Wire-Speed Switch Application

AT8989UP provides eight ports 100/10 Half/Full port plus one expansion bus with bandwidth up to 1.6Gbps. Two AT8989UPs can connect each other with the expansion bus to be a 16-port wire-speed Switching Hub. The expansion bus is implemented by the existing GMII interface at 100Mhz. Such configuration could get good result at both of Novell's Performance test and the HOL on smart-bit AST, even though it will increase latency around 12% across chips.

3.6 EEPROM Content

EEPROM provides AT8989UP many options setting such as:

- * Port Configuration: Speed, Duplex, and Flow Control Capability.
- * Special MII Register programming.
- * VLAN & TOS Priority Mapping
- * Broadcast Storming rate
- * Fiber Select, Auto MDIX select
- * VLAN Mapping
- * Per Port Buffer number

EEPROM Registers

Register	Bit 15- 8	Bit 7 - 0	Default Value
0x00h	Signature	Signature	4154h
0x01h	Port 0 Configuration	Port 0 Configuration	40fh
0x02h	Port 1 Configuration	Port 1 Configuration	40fh
0x03h	Port 2 Configuration	Port 2 Configuration	40fh
0x04h	Port 3 Configuration	Port 3 Configuration	40fh
0x05h	Port 4 Configuration	Port 4 Configuration	40fh
0x06h	Port 5 Configuration	Port 5 Configuration	40fh
0x07h	Port 6 Configuration	Port 6 Configuration	40fh
0x08h	Port 7 Configuration	Port 7 Configuration	40fh
0x09h	Port 8 Configuration	Port 8 Configuration	40fh



ATAN Technology, Inc.

0x0ah	Configuration		Configuration	0h
0x0bh	Customized MII Register for Port 8		Customized MII Register for Port 0~7	8000h
0x0ch	Port 0 ~ 7 MII Data High		Port 0 ~ 7 MII Data Low	fa50h
0x0dh	Port 8 MII Data High		Port 8 MII Data Low	fa50h
0x0eh	VLAN priority Map High		VLAN priority Map Low	fa50h
0x0fh	TOS priority Map High		TOS priority Map Low	fa50h
0x10h	Miscellaneous Configuration 0		Miscellaneous Configuration 0	aa40h
0x11h	Reserved		Reserved	ff00h
0x12h	Miscellaneous Configuration 1		Miscellaneous Configuration 1	3600h
0x13h	VLAN 0 outbound Port Map		VLAN 0 outbound Port Map	1ffh
0x14h	VLAN 1 outbound Port Map		VLAN 1 outbound Port Map	1ffh
0x15h	VLAN 2 outbound Port Map		VLAN 2 outbound Port Map	1ffh
0x16h	VLAN 3 outbound Port Map		VLAN 3 outbound Port Map	1ffh
0x17h	VLAN 4 outbound Port Map		VLAN 4 outbound Port Map	1ffh
0x18h	VLAN 5 outbound Port Map		VLAN 5 outbound Port Map	1ffh
0x19h	VLAN 6 outbound Port Map		VLAN 6 outbound Port Map	1ffh
0x1ah	VLAN 7 outbound Port Map		VLAN 7 outbound Port Map	1ffh
0x1bh	VLAN 8 outbound Port Map		VLAN 8 outbound Port Map	1ffh
0x1ch	VLAN 9 outbound Port Map		VLAN 9 outbound Port Map	1ffh
0x1dh	VLAN 10 outbound Port Map		VLAN 10 outbound Port Map	1ffh
0x1eh	VLAN 11 outbound Port Map		VLAN 11 outbound Port Map	1ffh
0x1fh	VLAN 12 outbound Port Map		VLAN 12 outbound Port Map	1ffh
0x20h	VLAN 13 outbound Port Map		VLAN 13 outbound Port Map	1ffh
0x21h	VLAN 14 outbound Port Map		VLAN 14 outbound Port Map	1ffh
0x22h	VLAN 15 outbound Port Map		VLAN 15 outbound Port Map	1ffh
0x23h	P1 Buffer Threshold		P0 Buffer Threshold	0h
0x24h	P3 Buffer Threshold		P2 Buffer Threshold	0h
0x25h	P5 Buffer Threshold		P4 Buffer Threshold	0h
0x26h	P7 Buffer Threshold		P6 Buffer Threshold	0h
0x27h	Threshold Sel	Total Buffer Threshold	P8 Buffer Threshold	0h

Signature Register:0x00h

Configuration	Description
---------------	-------------



ATAN Technology, Inc.

Bit [15:0]	The value must be 4154h(AT)
------------	-----------------------------

Configuration Registers: Register 0x01h ~ 0x09h

Configuration	Description
Bit 0	802.3x Flow control command ability
Bit 1	Auto negotiation Enable. High enable, Low disable
Bit 2	Speed. High 100TX, Low 10 Base-T
Bit 3	Duplex. High Full, Low Half
Bit 4	VLAN Tag or UnTag Port
Bit 5	Reserve
Bit 6	TOS over VLAN priority
Bit 7	Enable port-base priority
Bit [9:8]	Port-base priority
Bit [13:10]	PVID. Port base VLAN ID
Bit[14]	Select FX
Bit [15]	Crossover auto-detect enable

Configuration: Register 0x0ah

Configuration	Description
Bit [7:0]	Reserve
Bit 8	Reserve
Bit 9	Enable Replace VLAN ID 0 &1 by PVID
Bit [15:10]	Reserved

Customized MII Address Register: Register 0x0bh

Configuration	Description
Bit [4:0]	Port 0~7 MII Register Address
Bit 5	Port 0~7 MII Write Enable. High Active
Bit 6	Enable IPG leveling
Bit 7	Enable Trunk Port
Bit [12:8]	Port 8 MII Register Address
Bit 13	Port 8 MII Write Enable. High Active



ATAN Technology, Inc.

Bit 14	Reserve
Bit 15	Reserve

Customized MII Data Register: Register 0x00h

Configuration	Description
Bit [15:0]	Port 0~7 MII Data

Customized MII Data Register: Register 0x0dh

Configuration	Description
Bit [15:0]	Port 8 MII Data

VLAN(TOS) priority Map: Register 0x0eh (VLAN), 0x0fh(TOS)

Configuration	Description
Bit [1:0]	Mapped priority of tag value(VLAN, TOS) 0
Bit [3:2]	Mapped priority of tag value(VLAN, TOS) 1
Bit [5:4]	Mapped priority of tag value(VLAN, TOS) 2
Bit [7:6]	Mapped priority of tag value(VLAN, TOS) 3
Bit [9:8]	Mapped priority of tag value(VLAN, TOS) 4
Bit [11:10]	Mapped priority of tag value(VLAN, TOS) 5
Bit [13:12]	Mapped priority of tag value(VLAN, TOS) 6
Bit [15:14]	Mapped priority of tag value(VLAN, TOS) 7

00: lowest priority queue. Q0

01: lower priority queue. Q1

10: higher priority queue. Q2

11: highest priority queue. Q3

The weight ratio is Q0: Q1: Q2: Q3=1: 2: 4: 8. The default is Q1 for un-tag packet and none IP frame.

Miscellaneous Configuration: Register 0x10h

Configuration	Description
Bit [1:0]	Broadcast Storming Threshold[1:0]
Bit [2]	Broadcast Storming Enable
Bit [3]	Reserve
Bit [4]	XCRC (0/XCRCCHK, enable CRC Check)
Bit [5]	Reserve



ATAN Technology, Inc.

Bit [6]	SWCLK (switch rxclk to txclk for 7-wire)
Bit [7]	Aging Disable.
Bit [15:8]	Reserve

VLAN mode select Register: Register 0x11h, default value is 0xff00h :

Configuration	Description
Bit [4:0]	Reserved, default value 0
Bit [5]	VLAN mode select, default 0 0 : by-pass mode with port-base VLAN 1 : VLAN ID base VLAN.
Bit [7:6]	Reserved. Default value 0
Bit [15:8]	Reserved, default value 1

Miscellaneous Configuration: Register 0x12h

Configuration	Description			
Bit [8:0]	Unilrn8~0 (for security mode)			
Bit [10:9]	Reserve			
Bit [11]	Reserve			
Bit [13:12]	Power Saving Select			
EDI, Bit [14]	Recommend LED variety			
		Lnkact	Speed	Dupcol (always single color)
	00	Single color	Single color	Duplex/col
	01	Single color	Single color	duplex
	10	Dual color	Dual color	Duplex/col
	11	Dual color	Dual color	duplex

VLAN mapping table register: 0x13h~0x22h

Configuration	Description
Bit [8:0]	VLAN mapping table.

Per Port Buffer Threshold: 0x23h~0x26h

Configuration	Description
---------------	-------------



ATAN Technology, Inc.

Bit [13:8], Bit [5:0]	Port Buffer Threshold (available buffers are 8 times of the value)
-----------------------	--

Total Buffer Threshold: 0x27h

Configuration	Description
Bit [5:0]	Total Buffer Threshold for all ports
Bit 7	1: Enable EEPROM Threshold value, 0: default Threshold value

4. EEPROM Content Description

4.1 EEPROM Register Description:

Register 0x00h: Signature. Default value is 4154h. AT8989UP will check register 0 value before read EEPROM content. If this value do not match with 4154h then other values in EEPROM will be useless. AT8989UP will use internal defaulted value.

Register 0x01h~0x09h: Port 0~8 configuration register.

Bit 0: 802.3X Flow Control capability. 1: Enable; 0: Disable.

Bit 1: Auto Negotiation capability Enable. 1: Enable; 0: Disable.

Bit 2: Speed Capability when Bit 1 Enable. 1: 100; 0: 10.

Bit 3: Duplex Capability when Bit 1 Enable. 1: Full; 0: Half.

Bit 4: VLAN Tag Port. 1: set to Tag port; 0: set to Untag port.

Bit 5: Reserve.

Bit 6: TOS over VLAN Priority. Define AT8989UP priority source when VLAN & TOS existed in the packet.

1: TOS priority level higher than VLAN;

0: VLAN priority level higher than TOS. (default)

Bit 7: Enable Port Based Priority. 1: Enable; 0: Disable.

If this bit turn on, AT8989UP will not check TOS or VLAN as priority reference. AT8989UP will check port base priority only.

Bit[9:8]: Port base priority number. From 0~3 mapping to Q0~Q3.

Bit[13~10]: Port Base VLAN ID when packet without 4 bytes VLAN tag. If packet with 4 bytes VLAN then

AT8989UP will not add this VLAN ID to packet content. ID is from 0-15.

Bit[14]: Select FX interface. 1: FX; 0: TP;

Bit[15]: Auto MDIX enable. 1: Enable; 0: Disable.

Register 0x0ah: Configuration register.

Bit[7~0]: Reserve.

Bit 8: Reserve.

Bit 9: To replace VLAN ID 0 & 1 by PVID. 1: Enable; 0: Disable.

If this bit enable then AT8989UP will check VLAN ID. If this VLAN ID is 0 or 1 then AT8989UP will replace this ID by PVID.

Bit[15~10]: Reserved.

Register 0x0bh: Custom MII Address Register

Bit[4~0]: Reserve.

Bit 5: Reserve.

Bit 6: Enable IPG Leveling. 1: Enable. 0: Disable.

When this bit is enabled, AT8989UP will transmit packet out with 92 bit-time of IPG for test under SmartBit. If disable this function AT8989UP will transmit packet with 96 bit-time IPG for normal application.

Bit 7: Trunk port enable. 1: Enable, 0: Disable.

If enable, these Trunk port must be set at the same VLAN. The speed must run at 100M Full Duplex, regardless of



ATAN Technology, Inc.

other previous settings.

Bit[15~8]: Reserve.

Register 0x0ch: Reserve.

Register 0x0dh: Reserve.

Register 0x0eh: VLAN priority map

Value 00~11 are Q0~Q3 respectively.

Bit[1:0]: Mapped priority of VLAN tag value 0

Bit[3:2]: Mapped priority of VLAN tag value 1

Bit[5:4]: Mapped priority of VLAN tag value 2

Bit[7:6]: Mapped priority of VLAN tag value 3

Bit[9:8]: Mapped priority of VLAN tag value 4

Bit[11:10]: Mapped priority of VLAN tag value 5

Bit[13:12]: Mapped priority of VLAN tag value 6

Bit[15:14]: Mapped priority of VLAN tag value 7

Register 0x0fh: TOS priority map

Value 00~11 are Q0~Q3 respectively.

Bit[1:0]: Mapped priority of TOS value 0

Bit[3:2]: Mapped priority of TOS value 1

Bit[5:4]: Mapped priority of TOS value 2

Bit[7:6]: Mapped priority of TOS value 3

Bit[9:8]: Mapped priority of TOS value 4

Bit[11:10]: Mapped priority of TOS value 5

Bit[13:12]: Mapped priority of TOS value 6

Bit[15:14]: Mapped priority of TOS value 7

Register 0x10h: Miscellaneous Configuration Register.

Bit[1:0]: Broadcast Storming threshold. See Broadcast Threshold table.

Bit 2: Broadcast Storming Enable. 0: Disable. 1: Enable.

Bit 3: Reserve.

Bit 4: CRC check disable. 1: Disable. 0: Enable.

Bit 5: Reserve.

Bit 6: Switch RXCLK to TXCLK at GPSI interface. 1: Enable. 0: Disable.

Bit 7: Aging Disable. 1: Disable. 0: Enable.

Bit[15:8]: Reserve.

Register 0x11h:

Bit 5: VLAN mode select, default is “0”.

“0”, By-pass mode with port-base VLAN.

“1”, VLAN ID base VLAN.

Bit [15:6] : Reserve value “1”,

Bit [4:0] : Reserve value “0”.



Register 0x12h: Miscellaneous Configuration Register

- Bit 6: Enable IPG Leveling. 1: Enable. 0: Disable.
- Bit [8:0]: Port Locking enable. Learn one MAC ID when enable. 1: Enable. 0: Disable.
- Bit [10:9]: Reserve.
- Bit 11: Reserve.
- Bit [13:12]: Power Saving. 1: Enable. 0: Disable.
- Bit[14]: LED selection. See EEPROM content.
- Bit[15]: ENDC16 select excessive collision drop packet. 1: drop. 0: no drop.

Register 0x22h~0x13h: VLAN group 15~0 outbound port map. Default value 1ffh.

Each register bit0~8 directly point to port 0~8. Select the VLAN group ports is to set the corresponding bits to 1.

Register 0x26h~0x23h:

Bit[5:0] Port 7~0 Buffer Threshold when register 0x27h bit 15=1. Normal value is 03h.

Register 0x27h:

- Bit[5:0]: Port 8 buffer Threshold.
- Bit[12:8]: total buffer Threshold.
- Bit 15: Threshold selection enable. 1: Enable; 0: Disable.
When set at "1", At8989UP will set buffer threshold by the value of register0x26h~0x23h.

Packet with Priority:

Normal packet content

Ethernet Packet from Layer 2

Preamble/SFD	Destination (6 bytes)	Source (6 bytes)	Packet length (2 bytes)	Data (46-1500 bytes)	CRC (4 bytes)
	Byte 0~5	Byte 6~11	Byte 12~13	Byte 14~	

VLAN Packet

AT8989UP will check packet byte 12 &13. If byte[12:13]=8100h then this packet is a VLAN packet

Tag Protocol TD 8100	Tag Control Information TCI	LEN Length	Routing Information
Byte 12~13	Byte14~15	Byte 16~17	Byte 18

- Byte 14~15: Tag Control Information TCI
 - Bit[15:13]: User Priority 7~0
 - Bit 12: Canonical Format Indicator (CFI)
 - Bit[11~0]: VLAN ID. The AT8989UP will use bit[3:0] as VLAN group.

TOS IP Packet

AT8989UP check byte 12 &13 if this value is 0800h then AT8989UP knows this is a TOP priority packet.



ATAN Technology, Inc.

Type 0800	IP Header
-----------	-----------

Byte 12~13

Byte 14~15

IP header define

Byte 14

Bit[7:0]: IP protocol version number & header length.

Byte 15: Service type

Bit[7~5]: IP Priority (Precedence) from 7~0

Bit 4: No Delay (D)

Bit 3: High Throughput

Bit 2: High Reliability (R)

Bit[1:0]: Reserve

4.2 EEPROM Access

Customer can select AT8989UP read EEPROM contents as chip setting or not. AT8989UP will check the signature of

EEPROM to decide read content of EEPROM or not.

RESETL & EEPROM content relationship

RESETL	CS	SK	DI	DO
0	High Impedance	High Impedance	High Impedance	High Impedance
Rising edge 0→1 (30ms)	Output	Output	Output	Output
1 (after 30ms)	Input	Input	Input	Input

Keep at least 30ms after RESETL from 0→1. AT8989UP will read data from EEPROM. After RESETL=1, AT8989UP will update configuration registers too if CPU update EEPROM.

When CPU programs EEPROM & AT8989UP, AT8989UP will recognize the EEPROM WRITE instruction only. If there is any Protection instruction before or after the EEPROM WRITE instruction, CPU needs to generate a separated CS signal cycle for each Protection & WRITE instruction.

CPU can directly program AT8989UP after 30ms of Reset signal rising edge with or without the presence of EEPROM.

5. DC Characteristics

5.1 Absolute Maximum Rating

Symbol	Parameter	Rating	Units
V _{CCxx}	Power Supply	-0.3 to 3.63	V
V _{cca2}	TX line driver	-0.3 to 2.75	V
V _{ccpll}	PLL voltage	-0.3 to 2.75	V
V _{ccik}	Digital core voltage	-0.3 to 2.75	V
V _{IN}	Input Voltage	-0.3 to V _{CC} + 0.3	V
V _{out}	Output Voltage	-0.3 to V _{CC} + 0.3	V
T _{STG}	Storage Temperature	-55 to 155	°C
PD	Power Dissipation	4	W
T _c	Temperature of Package Case Surface	150	°C
ESD	ESD Rating	2KV	V

5.2 Recommended Operating Conditions

Symbol	Parameter	Min	Typ	Max	Units
V _{CC}	Power Supply	3.135	3.3	3.465	V
V _{cca2}	TX line driver		2.25		V
V _{ccpll}	PLL voltage		2.25		V
V _{ccik}	Digital core voltage		2.25		V
V _{in}	Input Voltage	0	-	V _{CC}	V
PC	Power consumption		2.6		W
T _j	Junction Operating Temperature	0	25		°C

5.3 DC Electrical Characteristics for 3.3V Operation

(Under V_{CC}=3.0V~3.6V, T_j= 0 °C ~ 125 °C)

Symbol	Parameter	Conditions	Min	Typ	Max	Units
V _{IL}	Input Low Voltage	CMOS			0.3 * V _{CC}	V
V _{IH}	Input High Voltage	CMOS	0.7 * V _{CC}			V
V _{OL}	Output Low Voltage	CMOS			0.4	V
V _{OH}	Output High Voltage	CMOS	0.7 * V _{CC}			V
R _I	Input Pull_up/down Resistance	V _{IL} =0V or V _{IH} = V _{CC}		100		KΩ

6. AC Characteristics

6.1. GRXD7_0, GRXDV, GRXER and GRXCLK Receive Signals Timing

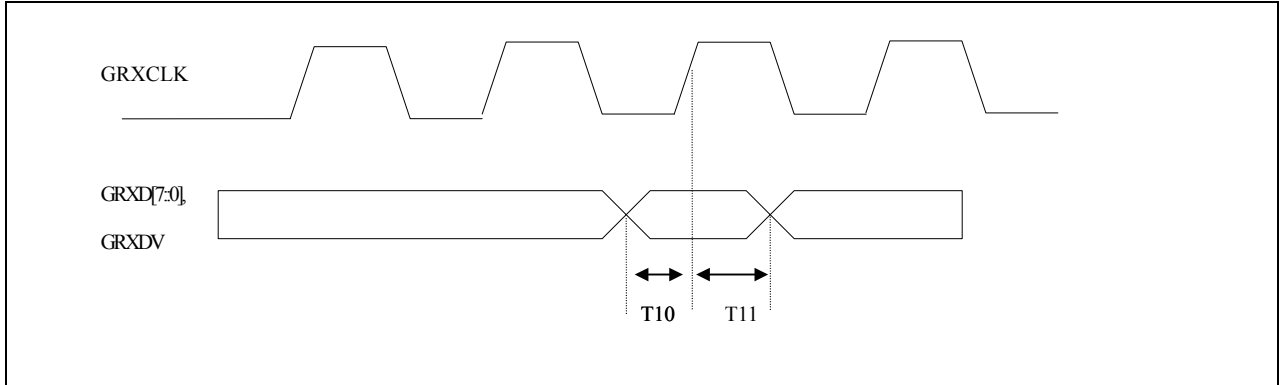

Name	Parameter	Min	Max	Units
T10	Setup Time to Rising GRXCLK	4		ns
T11	Hold Time to Rising GRXCLK	2		ns
GRXCLK Freq/125MHz, Period/8+- 0.5ns, GRXCLK high/2.5ns min, GRXCLK low/2.5ns min				

6.2. GTXD7_0, GTXEN, GTXER and GTXCLK Transmit Signals Timing

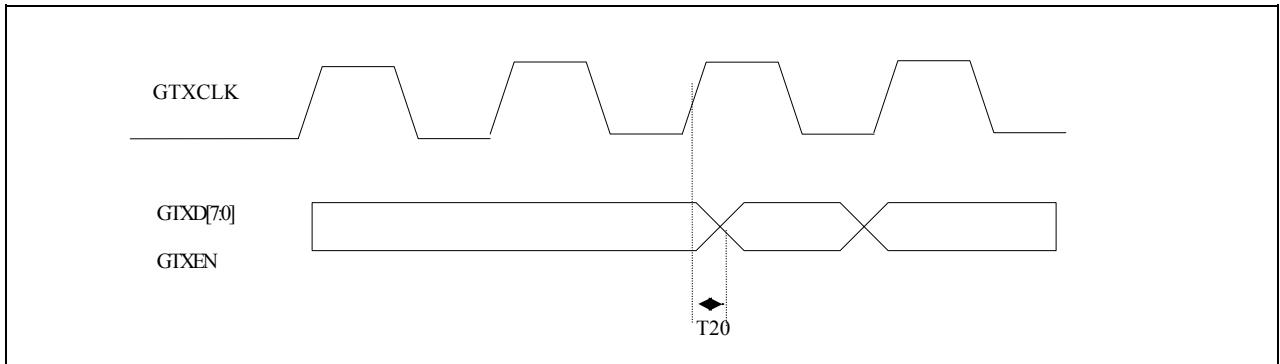

Name	Parameter	Min	Max	Units
T20	Data Valid Delay after Rising GTXCLK	1.5	4	ns
GTXCLK Freq/125MHz, Period/8+- 0.5ns, GTXCLK high/2.5ns min, GTXCLK low/2.5ns min				

6.3 EECS, EESK and EDI Signals Timing

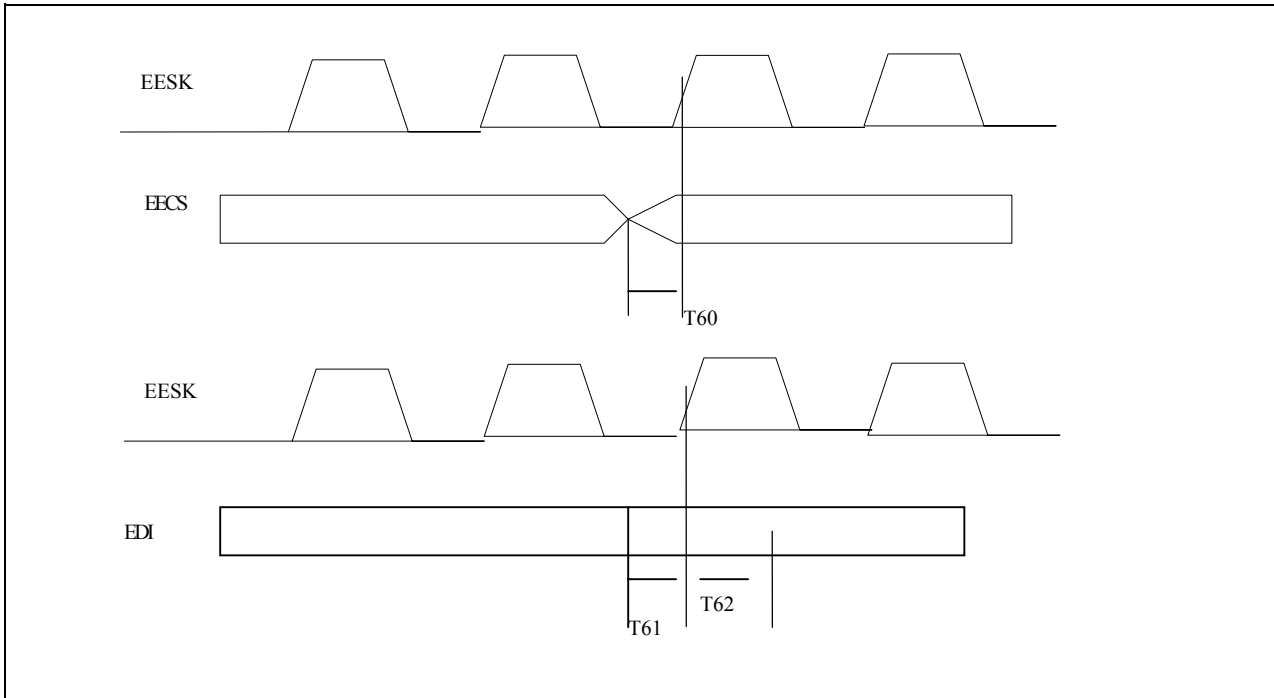

Name	Parameter	Min	Max	Units
T60	EECS to EESK setup time	10		ns
T61	EDI to EESK setup time	10		ns
T62	EDI to EESK hold time	10		ns

6.4 Expansion bus 1.6G Receive Signals Timing

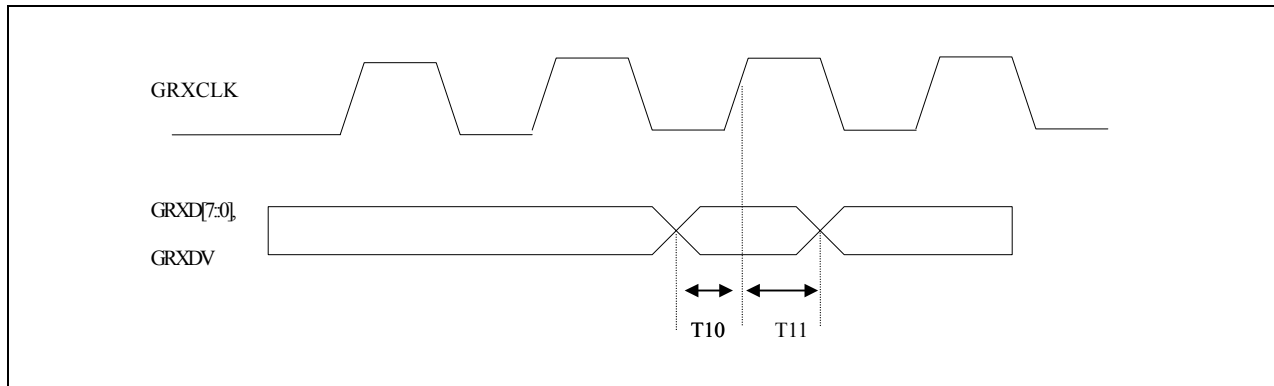



Name	Parameter	Min	Max	Units
T10	Setup Time to Rising GRXCLK	4		ns
T11	Hold Time to Rising GRXCLK	2		ns

6.5 Expansion 1.6G Transmit Signals Timing

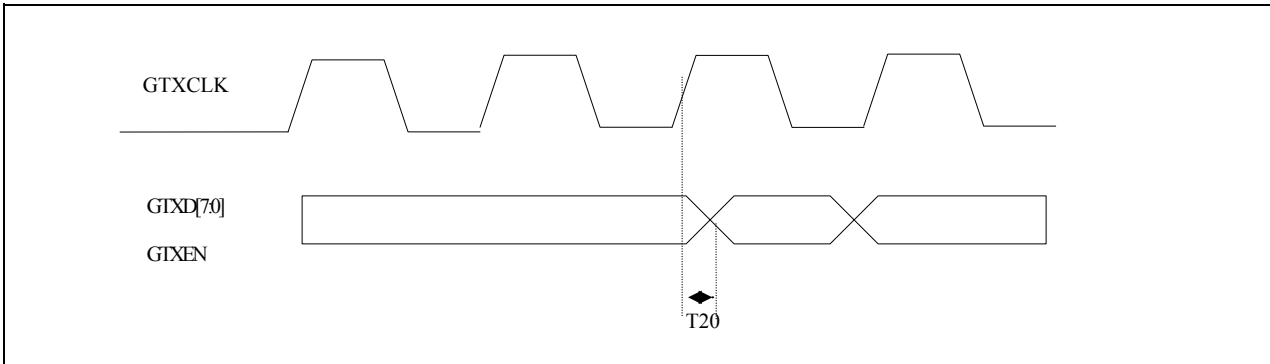

Name	Parameter	Min	Max	Units
T20	Data Valid Delay after Rising GTXCLK	1.5	4	ns

6.6 MII Receive Signals Timing

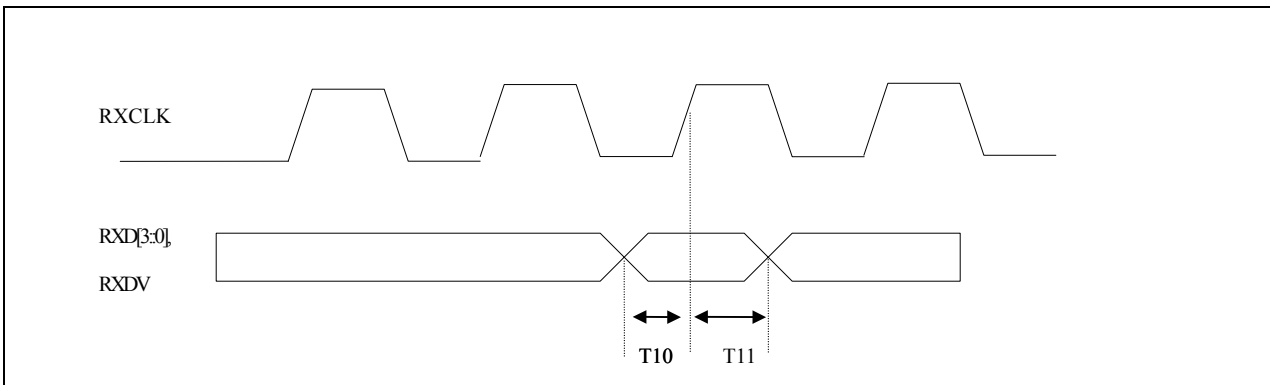

Name	Parameter	Min	Max	Units
T10	Setup Time to Rising RXCLK	4		ns
T11	Hold Time to Rising RXCLK	2		ns

6.7 MII Transmit Signals Timing

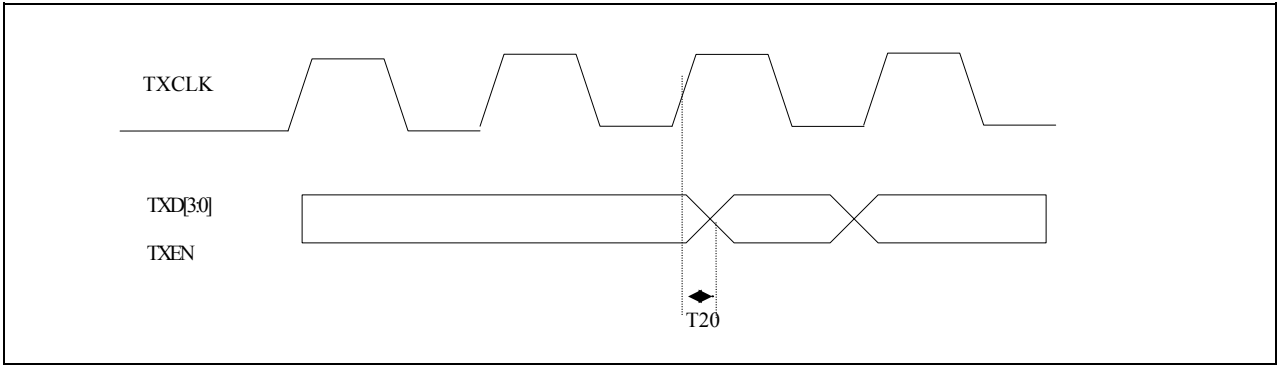

Name	Parameter	Min	Max	Units
T20	Data Valid Delay after Rising TXCLK	3	10	ns

6.8 PSI(7 wires) Transmit Signals Timing

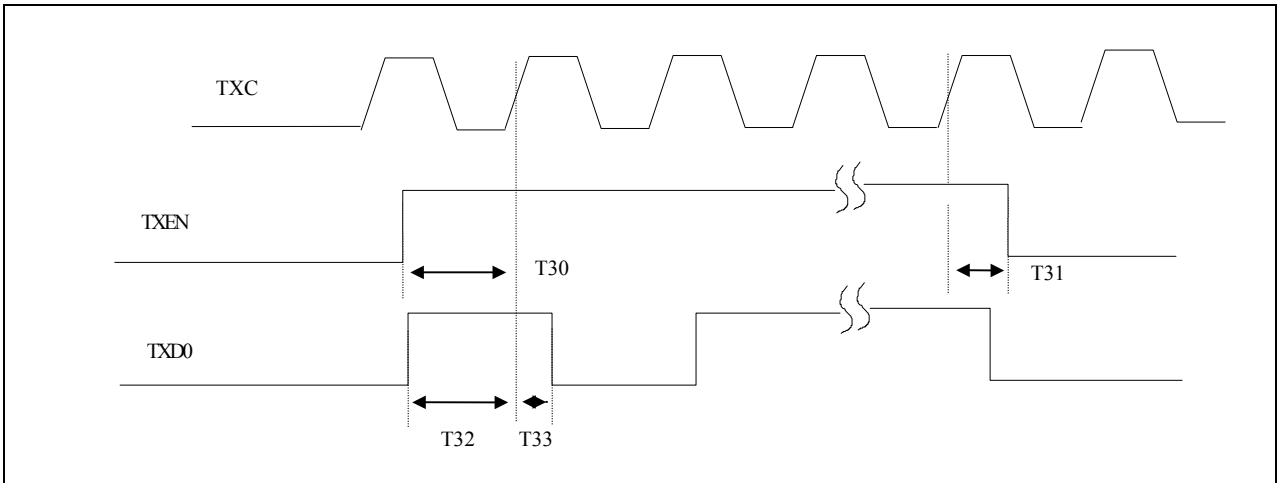

Name	Parameter	Min	Max	Units
T30	Transmit Enable Setup Time to TXC Rising	20		ns
T31	Transmit Enable Hold Time to TXC Rising	5		ns
T32	Transmit Data Setup Time to TXC Rising	20		ns
T33	Transmit Data Hold Time to TXC Rising	5		ns



ATAN Technology, Inc.

GPSI (7 wires) Receive Signals Timing

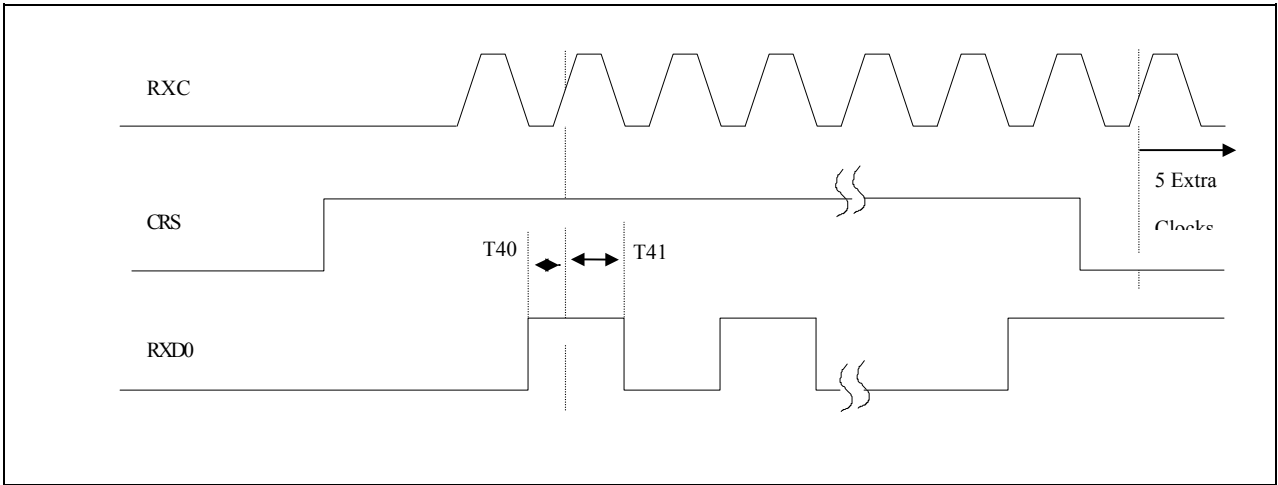

Name	Parameter	Min	Max	Units
T40	Receive Data Setup Time to RXC Rising	10		ns
T41	Receive Data Hold Time to RXC Rising	5		ns

7. Package

208 Pin PQFP Outside Dimension

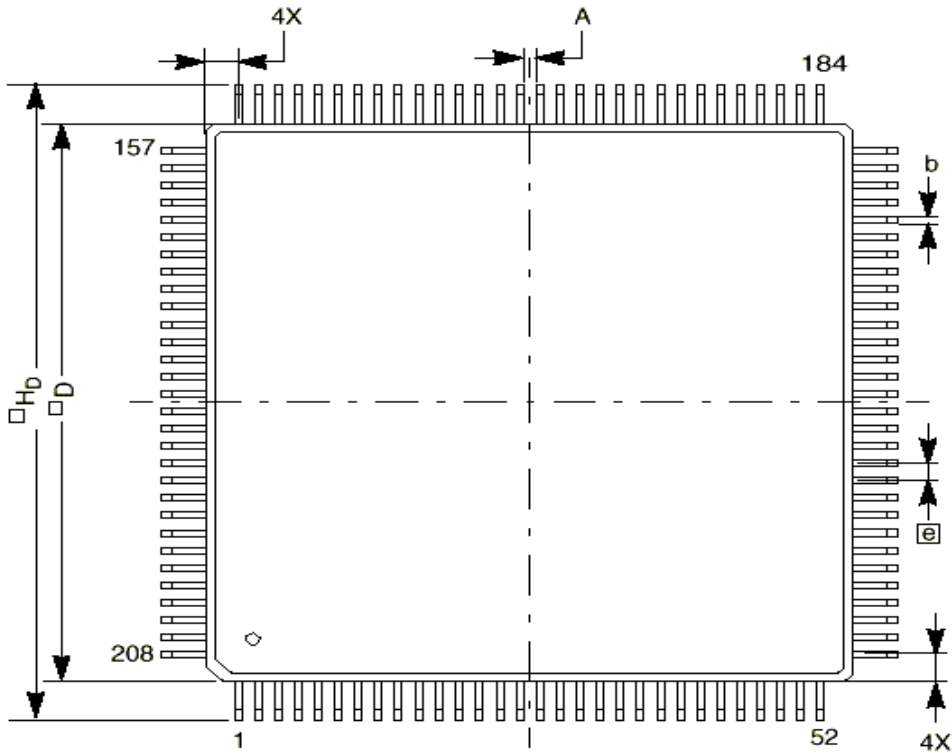

Symbol	Dimension: Inches			Dimension: Millimeters		
	Min	Nom	Max	Min	Nom	Max
A	--	--	0.145	--	--	3.68
A1	0.004	--	--	0.10	--	--
A2	0.122	0.127	0.132	3.10	3.23	3.35
b	0.006	0.008	0.010	0.15	0.20	0.25
c	0.004	0.006	0.010	0.10	0.15	0.25
D	1.097	1.102	1.107	27.87	28.00	28.13
E	1.097	1.102	1.107	27.87	28.00	28.13
Ⓜ	0.016	0.020	0.024	0.40	0.50	0.60
H _D	1.193	1.205	1.217	30.30	30.60	30.90
L	0.012	0.020	0.028	0.30	0.50	0.70
L1	0.043	0.051	0.059	1.10	1.30	1.50
y	--	--	0.004	--	--	0.10
θ	0°	--	10°	0°	--	10°

