



## • RF Signal Processors (continued)

Type	Function	Package		Features	Reference Catalog
		Configuration	No. of pins		
BA4405	FM front end	SIP	7	Higher gain than the BA4403.	No.3121
BA4408F	1.5V FM front end	MF	14	Equipped with RF amplifier, mixer, OSC, IF amplifier and vari-cap for AFC.	No.3121
BA4411	FM front end	SIP	9	Double balance mixer system. High gain. $V_{CC}=2$ to 8V operation With vari-cap for AFC, IF amplifier. 3 types available to accommodate IF gain.	No.3121
BA4412	FM front end	SIP	9		
BA4413	FM front end	SIP	9		
BA4422AN	FM/TV front end	SIP	9	Receive TV frequency. High gain. With vari-cap for AFC.	No.3121
BA4424N	FM/TV front end	SIP	9	Receive TV frequency. High gain. With vari-cap for AFC. $V_{CC}=1.7$ to 6V operation. Excellent two-signal characteristics	No.3121
BA4425F	FM/TV front end	MF	8	Receives TV frequencies as well; High gain; Operable on $V_{CC}=1.7$ to 6V; Excellent two-signal characteristics	—
BA1332/BA1332L	FM stereo multiplexer	DIP/LF	16	Operates with supply voltage in the range 3 to 14V. Low current consumption (9mA).	No.3121
BA1335	FM stereo multiplexer	DIP	16	High-performance multiplexer using a PLL. Operates with high stability at supply voltages down to 3.3V.	No.3121
BA1350	FM stereo multiplexer with noise controller	LF	16	Operates with supply voltage in the range 6 to 12V. Wide dynamic range and low distortion. DC control is used for linked control of separation and cutoff ratio.	No.3121
BA1351	FM stereo multiplexer with noise controller	DIP	16		
BA1355/BA1355F	FM stereo multiplexer with noise controller	DIP/MF	16	DC control for independent varying of cutoff ratio (independently settable $\tau$ ). Forced monaural pin and VCO inhibiting pin for passing AM signals.	No.3121
BA1356	FM stereo multiplexer with noise controller	LF	16		
BA1360/BA1360F	3V FM stereo multiplexer	LF/MF	16	Operates with supply voltage in the range 1.8 to 4V. Wide dynamic range and low distortion. Forced monaural pin and VCO inhibiting pin for passing AM signals.	No.3121
BA1362F/BA1362FS	1.5V FM stereo multiplexer	MF/MFS	16	Forced monaural pin and VCO inhibiting pin for passing AM signals. Built-in output resistance. Supply voltage range for stereo operation: $V_{CC}=1.0$ to 2.5V	No.3121
BA1440	FM/AM-IF system + FM stereo multiplexer	DIP	18	$V_{CC}=3.5$ to 7V operation; no AM IFT required; adjustment-free FM quadrature detector; inverse S-shaped curve covered by two models.	No.3121
BA1441	FM/AM-IF system + FM stereo multiplexer	DIP	18		
BA1402/BA1402F	3V FM stereo reception system	DIP/MF	22	3V power supply, quadrature detection. FM-IF and Multiplexer.	No.2700
BA1404/BA1404F	FM stereo transmitter	DIP/MF	18	Internal stereo modulator and RF oscillator; (Operates with supply voltage in the range 1.0 to 2.0V).	No.2700
BA1407AL/BA1407AF	TV multiplex demodulator	LF/MF	18/20	Internal mode switching between STEREO, MAIN, SUB, and MAIN/SUB; broad supply voltage range of 4-11V; two versions with different audio subchannel sensing hysteresises available.	No.3121
BA1407BL	TV multiplex demodulator	LF	18		—

## • Power Amplifiers

BA5152F	1.5V/15mW Dual power amplifier	MF	16	15mW×2 output at 1.5V/16 $\Omega$ (THD=10%). Less pop noise. Built-in power supply switch.	No.3121
BA5204/BA5204F	3V/35mW Dual power amplifier	LF/MF	16	35mW×2 output at 3V/32 $\Omega$ (THD=10%).	No.3121
BA5206BF	3V/64mW Dual power amplifier	MF	16	64mW×2 output at 3V/16 $\Omega$ (THD=10%). Very little pop noise.	No.3121
BA526	6V/430mW Single power amplifier	SIP	9	430mW output at 6V/8 $\Omega$ (THD=10%). Better voltage reduction characteristics. Operation start voltage of 2V.	No.3121
BA527	6V/800mW Single power amplifier	SIP	9	800mW output at 6V/4 $\Omega$ (THD=10%). Ripple rejection factor as high as 55dB, (Typ.). Less pop noise.	No.3121
BA546	6V/330mW Single power amplifier	SIP	9	330mW output at 6V/8 $\Omega$ (THD=10%). Better voltage reduction characteristics. Operation start voltage of 2V.	No.3121
BA534	9V/2.3W Single power amplifier	SIP-P	10	2.8W output at 9V/3 $\Omega$ or 2.3W out at 9V/4 $\Omega$ (THD=10%). Better ripple attenuation (53dB, Typ.).	No.3121
BA5410	9V/2.9W, 12V/5.2W Dual power amplifier	SIP-P	10	2.9W×2 output at 9V/3 $\Omega$ or 5.2W×2 output at 12V/3 $\Omega$ (THD=10%). Few external parts required	No.3121
BA5412	9V/1.5W Dual power amplifier	SIP-P	12	Delivers 2.5 watts×2 (THD=10%) into 4-home loads at 9V supply.	—
BA5404	12V/360mW Single power amplifier	SIP	9	360mW output at 12V/32 $\Omega$ (THD=10%).	No.3121
BA5406	12V/5W Dual power amplifier	SIP-P	12	5W×2 output at 12V/3 $\Omega$ (THD=10%). Less pop noise.	No.3121
BA5413	12V/5.4W Dual power amplifier	SIP-P	12	5.4W×2 output at 12V/3 $\Omega$ (THD=10%) THD=0.09%	—
BA532	13.2V/5.8W Single power amplifier	SIP-P	10	5.8W output at 13.2V/4 $\Omega$ (THD=10%). Less pop noise.	—

Dimensions (Unless otherwise specified, dimensions are shown in Typ. values.)

SIP

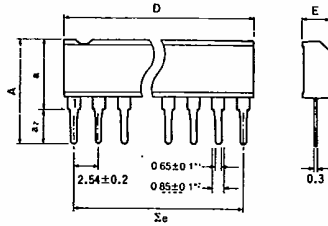

• SIP Dimensions (Unit: mm)

Package	A	a	a <sub>2</sub>	D	Σe	E
SIP 5	9.7	6.2	3.5	12.0	10.16	2.4
SIP 7	9.7	6.2	3.5	17.0	15.24	2.8
SIP 8	10.5	7.0	3.5	19.5	17.78	2.8
SIP 9	10.5	7.0	3.5	22.0	20.32	2.8
SIP 10	10.5	7.0	3.5	25.2	22.86	2.8

\*1 SIP 10pin: 0.6 \*2 SIP 10pin: 0.8

DIP/DIPS

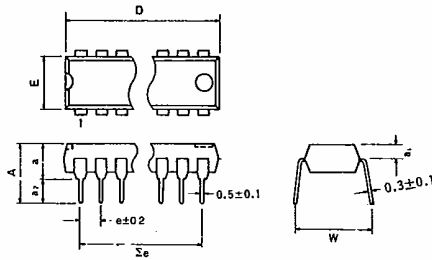

• DIP Dimensions (Unit: mm)

Package	A	a	a <sub>1</sub>	a <sub>2</sub>	D	e	Σe	E	W
DIP 8	6.8	3.6	1.1	3.2	9.3	2.54	7.62	6.5	8.8
DIP 14	6.94	3.65	1.65	3.29	19.4	2.54	15.24	6.5	8.8
DIP 16	6.94	3.65	1.65	3.29	19.4	2.54	17.78	6.5	8.8
DIP 18	6.94	3.65	1.65	3.29	22.9	2.54	20.32	6.5	8.8
DIP 20	7.09	3.65	1.65	3.44	26.3	2.54	22.86	6.5	8.8
DIP 22	7.09	3.65	1.65	3.44	26.3	2.54	25.40	6.5	8.8
DIP 24	7.51	4.22	1.8	3.29	32.0	2.54	27.94	13.8	16.5
DIP 28	7.51	4.22	1.8	3.29	37.1	2.54	33.02	13.8	16.5
DIP 40	7.7	4.5	1.8	3.2	52.3	2.54	48.26	13.8	16.5
DIPS 18	7.35	3.65	1.65	3.7	19.4	1.778	14.224	6.5	8.8
DIPS 22	7.35	3.65	1.65	3.7	19.4	1.778	17.78	6.5	8.8
DIPS 24	7.4	4.0	1.7	3.4	22.8	1.778	19.558	6.5	8.8
DIPS 30	7.9	4.7	1.7	3.2	28.0	1.778	24.892	8.4	11.4
DIPS 32	7.9	4.7	1.7	3.2	28.0	1.778	26.67	8.4	11.4
DIPS 42	7.7	4.5	1.8	3.2	37.1	1.778	35.56	13.8	16.5

MF/MFS/MFP

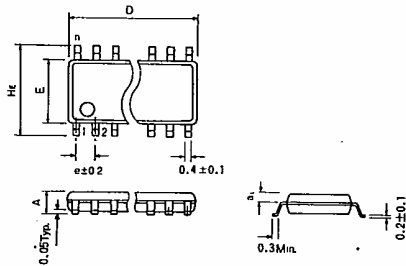

• MF Dimensions (Unit: mm)

Package	A	a <sub>1</sub>	D	H <sub>e</sub>	e	E
MF 8	1.5	0.65	5.0	6.2	1.27	4.4
MF 14	1.5	0.65	8.7	6.2	1.27	4.4
MF 16	1.5	0.65	10.0	6.2	1.27	4.4
MF 18	1.8	0.8	11.2	7.8	1.27	5.4
MF 20	1.8	0.8	12.5	7.8	1.27	5.4
MF 22	1.8	0.8	13.7	7.8	1.27	5.4
MF 24	1.8	0.8	15.0	7.8	1.27	5.4
MF 28	2.2	1.0	18.5	9.9	1.27	7.5
MFS 16	1.5	0.65	6.6	6.2	0.8	4.4
MFS 20	1.8	0.8	8.7	7.8	0.8	5.4
MFS 24	1.8	0.8	10.0	7.8	0.8	5.4
MFP 24	1.9	0.8	13.7	7.8	0.8	5.4
MFP 28	2.2	0.95	18.5	9.9	0.8	7.5

LF/LFS

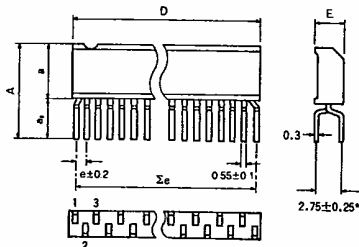

• LF Dimensions (Unit: mm)

Package	A	a	a <sub>2</sub>	D	Σe	e	E
LF 9	9.8	5.0	4.8	12.0	10.16	1.27	2.4
LF 12	9.8	5.0	4.8	17.0	13.97	1.27	2.8
LF 16	9.9	5.8	4.1	19.5	19.05	1.27	2.8
LF 18	9.9	5.8	4.1	22.0	21.59	1.27	2.8
LFS 24	10.0	5.8	4.2	22.0	20.447	0.889	2.8

\*LFS 24: 2.54±0.25

QFP/QFPS

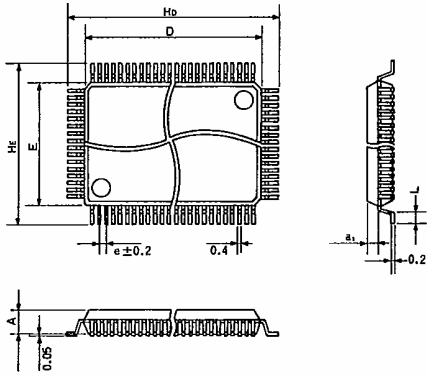

• QFP Dimensions (Unit: mm)

Package	A	$a_1$	D	$e$	E	$H_E$	$H_D$	L
QFP 32	1.45	0.65	7.0	0.8	7.0	9.0	9.0	0.4
QFP 44	2.15	1.0	10.0	0.8	10.0	14.0	14.0	1.2
QFP 64	2.15	1.0	20.0	1.0	14.0	18.0	24.0	1.2
QFP 80	2.7	1.275	20.0	0.8	14.0	18.0	24.0	1.2
QFPS 56	2.15	1.0	10.0	0.65	10.0	12.4	12.4	0.5
QFPS 80	2.7	1.275	14.0	0.65	14.0	16.4	16.4	0.5
QFPS 100	2.7	1.275	20.0	0.65	14.0	18.0	24.0	1.2

SIP-P 10 pin

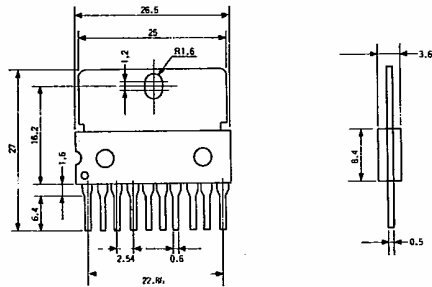

SIP-P 12 pin

