

Linear Building Block – Dual Low Power Comparator and Voltage Reference with Shutdown

Features

- Combines Two Comparators and a Voltage Reference in a Single Package
- Optimized for Single Supply Operation
- Small Package: 8-Pin MSOP
- Ultra Low Input Bias Current: Less than 100pA
- Low Quiescent Current, Operating: 10 μ A (Typ.)
Shutdown Mode: 0.05 μ A (Typ.)
- Rail-to-Rail Inputs and Outputs
- Operates Down to $V_{DD} = 1.8V$

Applications

- Power Supply Circuits
- Battery Operated Equipment
- Consumer Products
- Replacements for Discrete Components

Device Selection Table

Part Number	Package	Temperature Range
TC1028CEUA	8-Pin MSOP	-40°C to +85°C

Package Type

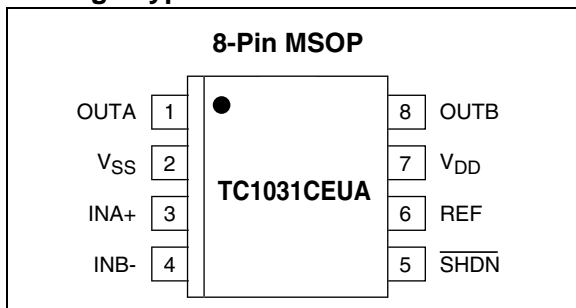

General Description

The TC1028 is a mixed-function device combining two comparators and a voltage reference in a single 8-pin package. The inverting input of Comparator A and the non-inverting input of Comparator B are internally connected to the reference.

This increased integration allows the user to replace two packages, which saves space, lowers supply current and increases system performance. The TC1028 operates from two 1.5V alkaline cells down to $V_{DD} = 1.8V$. It requires only 10 μ A typical of supply current, which significantly extends battery life. A low power shutdown input (SHDN) disables the entire chip, placing all outputs in a high-impedance state. This mode saves battery power and allows comparator outputs to share common analog lines (multiplexing). Shutdown current is 0.05 μ A typical.

Rail-to-rail inputs and outputs allow operation from low supply voltages with large input and output signal swings.

Packaged in an 8-Pin MSOP, the TC1028 is ideal for applications requiring low power level detection.

Functional Block Diagram

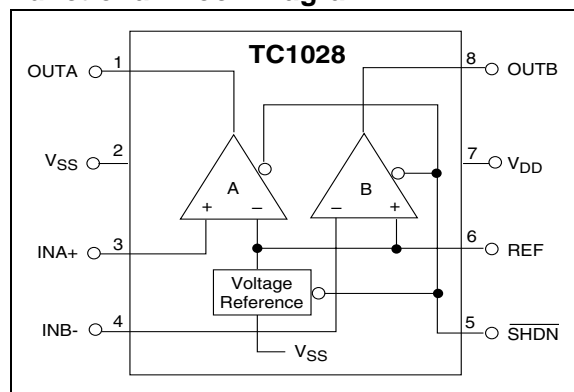

TC1028

1.0 ELECTRICAL CHARACTERISTICS

ABSOLUTE MAXIMUM RATINGS*

Supply Voltage	6.0V
Voltage on Any Pin	(V _{SS} - 0.3V) to (V _{DD} + 0.3V)
Junction Temperature.....	+150°C
Operating Temperature Range.....	-40°C to +85°C
Storage Temperature Range	-55°C to +150°C

*Stresses above those listed under "Absolute Maximum Ratings" may cause permanent damage to the device. These are stress ratings only and functional operation of the device at these or any other conditions above those indicated in the operation sections of the specifications is not implied. Exposure to Absolute Maximum Rating conditions for extended periods may affect device reliability.

TC1028 ELECTRICAL SPECIFICATIONS

Electrical Characteristics: Typical values apply at 25°C and V _{DD} = 3.0V. Minimum and maximum values apply for T _A = -40° to +85°C, and V _{DD} = 1.8V to 5.5V, unless otherwise specified.						
Symbol	Parameter	Min	Typ	Max	Units	Test Conditions
V _{DD}	Supply Voltage	1.8	—	5.5	V	
I _Q	Supply Current Operating	—	10	15	μA	All outputs unloaded, $\overline{\text{SHDN}} = V_{\text{DD}}$
I _{SHDN}	Supply Current, Shutdown	—	0.05	0.1	μA	$\overline{\text{SHDN}} = V_{\text{SS}}$
Shutdown Input						
V _{IH}	Input High Threshold	80% V _{DD}	—	—	V	
V _{IL}	Input Low Threshold	—	—	20% V _{DD}	V	
I _{SI}	Shutdown Input Current	—	—	±100	nA	
Comparators						
R _{OUT}	Output Resistance in Shutdown	20	—	—	MΩ	$\overline{\text{SHDN}} = V_{\text{SS}}$
C _{OUT}	Output Capacitance in Shutdown	—	—	5	pF	$\overline{\text{SHDN}} = V_{\text{SS}}$
T _{SEL}	Select Time	—	20	—	μsec	V _{OUT} Valid from $\overline{\text{SHDN}} = V_{\text{IH}}$
T _{DESEL}	Deselect Time	—	500	—	nsec	V _{OUT} Invalid from $\overline{\text{SHDN}} = V_{\text{IL}}$ R _L = 10kΩ to V _{SS}
V _{IR}	Input Voltage Range	V _{SS} - 0.2	—	V _{DD} + 0.2	V	
V _{OS}	Input Offset Voltage	-5 -5	—	+5 +5	mV	V _{DD} = 3V, T _A = 25°C T _A = -40°C to 85°C
I _B	Input Bias Current	—	—	±100	pA	T _A = 25°C, INA+, INB- = V _{DD} to V _{SS}
V _{OH}	Output High Voltage	V _{DD} - 0.3	—	—	V	R _L = 10kΩ to V _{SS}
V _{OL}	Output Low Voltage	—	—	0.3	V	R _L = 10kΩ to V _{DD}
CMRR	Common Mode Rejection Ratio	66	—	—	dB	T _A = 25°C, V _{DD} = 5V V _{CM} = V _{DD} to V _{SS}
PSRR	Power Supply Rejection Ratio	60	—	—	dB	T _A = 25°C, V _{DD} = 1.8V to 5V
I _{SRC}	Output Source Current	1	—	—	mA	INA+ = V _{DD} , INB- = V _{SS} Output Shorted to V _{SS} V _{DD} = 1.8V
I _{SINK}	Output Sink Current	2	—	—	mA	INA+ = V _{SS} , INB- = V _{DD} Output Shorted to V _{DD} V _{DD} = 1.8V
t _{PD1}	Response Time	—	4	—	μsec	100mV Overdrive, C _L = 100pF
t _{PD2}	Response Time	—	6	—	μsec	10mV Overdrive, C _L = 100pF
Voltage Reference						
V _{REF}	Reference Voltage	1.176	1.200	1.224	V	
I _{REF(SOURCE)}	Source Current	50	—	—	μA	
I _{REF(SINK)}	Sink Current	50	—	—	μA	
C _{L(REF)}	Load Capacitance	—	—	100	pF	
R _{OUT(SD)}	Output Resistance in Shutdown	20	—	—	MΩ	$\overline{\text{SHDN}} = V_{\text{SS}}$
C _{OUT(SD)}	Output Capacitance in Shutdown	—	—	5	pF	$\overline{\text{SHDN}} = V_{\text{SS}}$

TC1028 ELECTRICAL SPECIFICATIONS (CONTINUED)

Electrical Characteristics: Typical values apply at 25°C and $V_{DD} = 3.0V$. Minimum and maximum values apply for $T_A = -40^\circ$ to $+85^\circ C$, and $V_{DD} = 1.8V$ to $5.5V$, unless otherwise specified.

Symbol	Parameter	Min	Typ	Max	Units	Test Conditions
T_{SEL}	Select Time	—	200	—	μsec	REF Valid from $\overline{\text{SHDN}} = V_{IH}$ $R_L = 100k\Omega$ to V_{SS}
T_{DESEL}	Deselect Time	—	10	—	μsec	REF Invalid from $\overline{\text{SHDN}} = V_{IL}$ $R_L = 100k\Omega$ to V_{SS}
$C_{L(REF)}$	Load Capacitance	—	—	100	pF	
E_{VREF}	Noise Voltage	—	20	—	μV_{RMS}	100Hz TO 100kHz
e_{VREF}	Noise Voltage Density	—	1.0	—	$\mu V/\sqrt{Hz}$	1kHz

TC1028

2.0 PIN DESCRIPTION

The description of the pins are listed in Table 2-1.

TABLE 2-1: PIN FUNCTION TABLE

Pin No. (8-Pin MSOP)	Symbol	Description
1	OUTA	Comparator output.
2	V_{SS}	Negative power supply.
3	INA+	Non-inverting input to Comparator A.
4	INB-	Inverting input to Comparator B.
5	$\overline{\text{SHDN}}$	Shutdown input.
6	REF	Voltage reference.
7	V_{DD}	Positive power supply.
8	OUTB	Comparator output.

3.0 DETAILED DESCRIPTION

The TC1028 is one of a series of very low power, linear building block products targeted at low voltage, single supply applications. The TC1028 minimum operating voltage is 1.8V and typical supply current is only 10 μ A (fully enabled). It combines two comparators and a voltage reference in a single package. The shutdown mode disables both comparators and the reference. All of the outputs are in a high impedance state during shutdown.

3.1 Comparators

The TC1028 contains two comparators. The comparator's input range extends beyond both supply voltages by 200mV and the outputs will swing to within several millivolts of the supplies depending on the load current being driven. The inverting input of Comparator A and the non-inverting input of Comparator B are internally connected the output of the voltage reference.

The comparators exhibit a propagation delay and supply current which are largely independent of supply voltage. The low input bias current and offset voltage make them suitable for high impedance precision applications. Both comparators are disabled during shutdown and have high impedance outputs.

3.2 Voltage Reference

A 2.0% tolerance, internally biased, 1.20V bandgap voltage reference is included in the TC1028. It has a push-pull output capable of sourcing and sinking 50 μ A. The voltage reference is disabled during shutdown, with a high impedance output.

3.3 Shutdown Input

$\overline{\text{SHDN}}$ at V_{IL} disables the entire part. The $\overline{\text{SHDN}}$ input cannot be allowed to float; when not used, connect it to V_{DD} . All outputs are in a high impedance state when shutdown is active. The disabled comparators' inputs and outputs can be driven from rail-to-rail by an external voltage when the TC1028 is in shutdown. No latchup will occur when the device is driven to its enabled state when SHDN is set to V_{IH} .

4.0 TYPICAL APPLICATIONS

The TC1028 lends itself to a wide variety of applications, particularly in battery-powered systems. It typically finds application in power management, processor supervisory and interface circuitry.

4.1 Wake-Up Timer

Many microcontrollers have a low-power "sleep" mode that significantly reduces their supply current. Typically, the microcontroller is placed in this mode via a software instruction, and returns to a fully-enabled state upon reception of an external signal ("wake-up"). The wake-up signal is usually supplied by a hardware timer. Most system applications demand that this timer have a long duration (typically seconds or minutes), and consume as little supply current as possible.

The circuit shown in Figure 4-1 is a wake-up timer made from Comparator A. Capacitor C1 charges through R1 until a voltage equal to V is reached, at which point the "wake-up" is driven active. Upon wake-up, the microcontroller resets the timer by forcing a logic low on a dedicated, open drain I/O port pin. This discharges C1 through R4 (the value of R4 is chosen to limit maximum current sunk by the I/O port pin). With a 3V supply, the circuit as shown consumes typically 10 μ A and furnishes a nominal timer duration of 25 seconds.

FIGURE 4-1: WAKE-UP TIMER

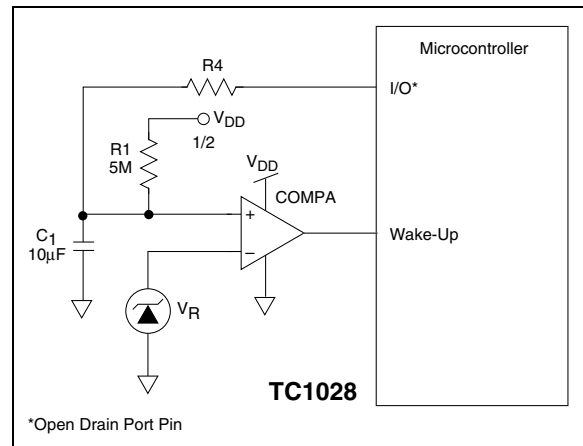

4.2 Precision Battery Monitor

Figure 4-2 is a precision battery low/battery dead monitoring circuit. Typically, the battery low output warns the user that a battery dead condition is imminent. Battery dead typically initiates a forced shutdown to prevent operation at low internal supply voltages (which can cause unstable system operation).

The circuit in Figure 4-2 uses a single TC1028, a TC1034, and only six external resistors. COMPA and COMPB provide precision voltage detection using V_R as a reference. Resistors R2 and R4 set the detection threshold for BATT LOW, while resistors R1 and R3 set the detection threshold for BATT FAIL. The component values shown assert BATT LOW at 2.2V (typical) and BATT FAIL at 2.0 (typical). Total current consumed by this circuit is typically 16 μ A at 3V. Resistors R5 and R6 provide hysteresis for comparators COMPA and COMPB, respectively.

4.3 External Hysteresis (Comparator)

Hysteresis can be set externally with two resistors using positive feedback techniques (see Figure 4-3). The design procedure for setting external comparator hysteresis is as follows:

1. Choose the feedback resistor R_C . Since the input bias current of the comparator is at most 100pA, the current through R_C can be set to 100nA (i.e., 1000 times the input bias current) and retain excellent accuracy. The current through R_C at the comparator's trip point is V_R / R_C where V_R is a stable reference voltage.
2. Determine the hysteresis voltage (V_{HY}) between the upper and lower thresholds.

3. Calculate R_A as follows:

EQUATION 4-1:

$$R_A = R_C \left(\frac{V_{HY}}{V_{DD}} \right)$$

4. Choose the rising threshold voltage for V_{SRC} (V_{THR}).
5. Calculate R_B as follows:

EQUATION 4-2:

$$R_B = \frac{1}{\left[\left(\frac{V_{THR}}{V_R \times R_A} \right) - \frac{1}{R_A} - \frac{1}{R_C} \right]}$$

6. Verify the threshold voltages with these formulas:

V_{SRC} rising:

EQUATION 4-3:

$$V_{THR} = (V_R)(R_A) \left[\left(\frac{1}{R_A} \right) + \left(\frac{1}{R_B} \right) + \left(\frac{1}{R_C} \right) \right]$$

V_{SRC} falling:

EQUATION 4-4:

$$V_{THF} = V_{THR} - \left[\left(\frac{R_A \times V_{DD}}{R_C} \right) \right]$$

FIGURE 4-2: PRECISION BATTERY MONITOR

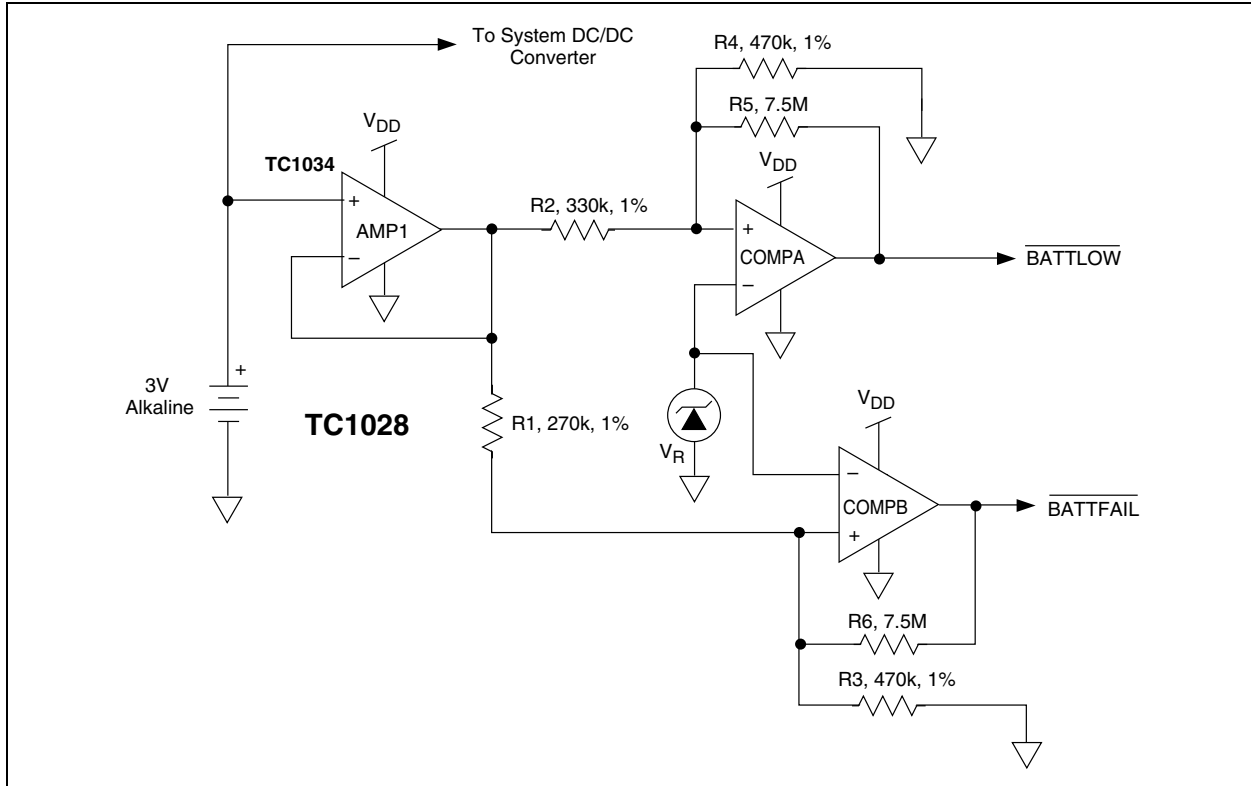
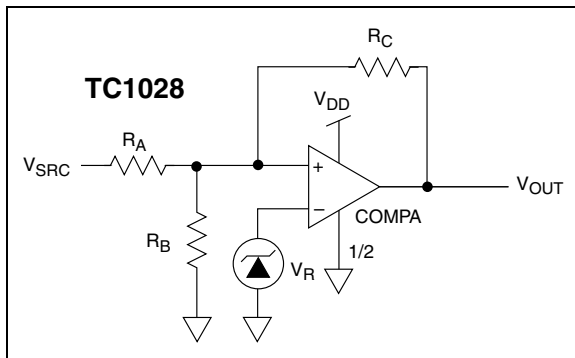
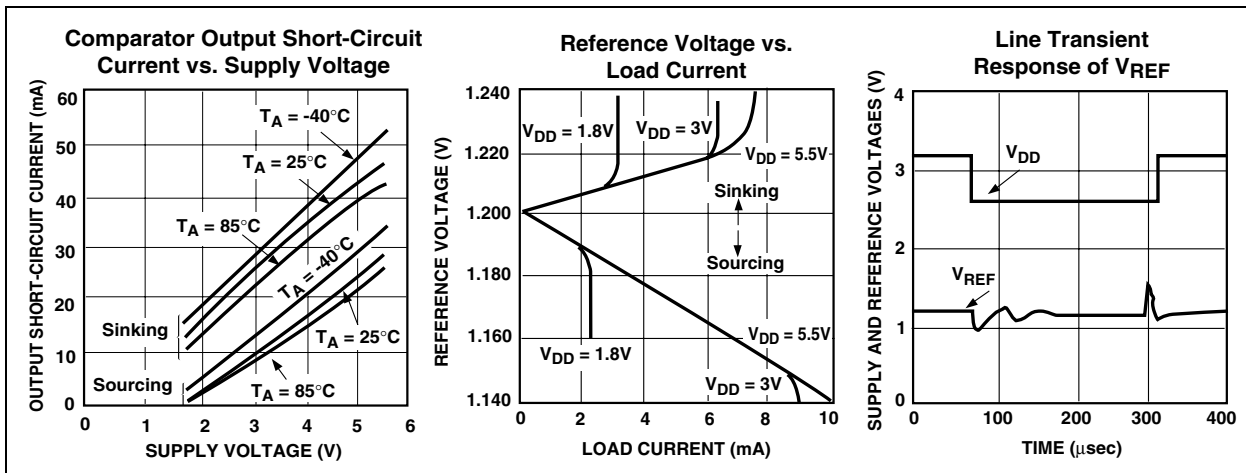
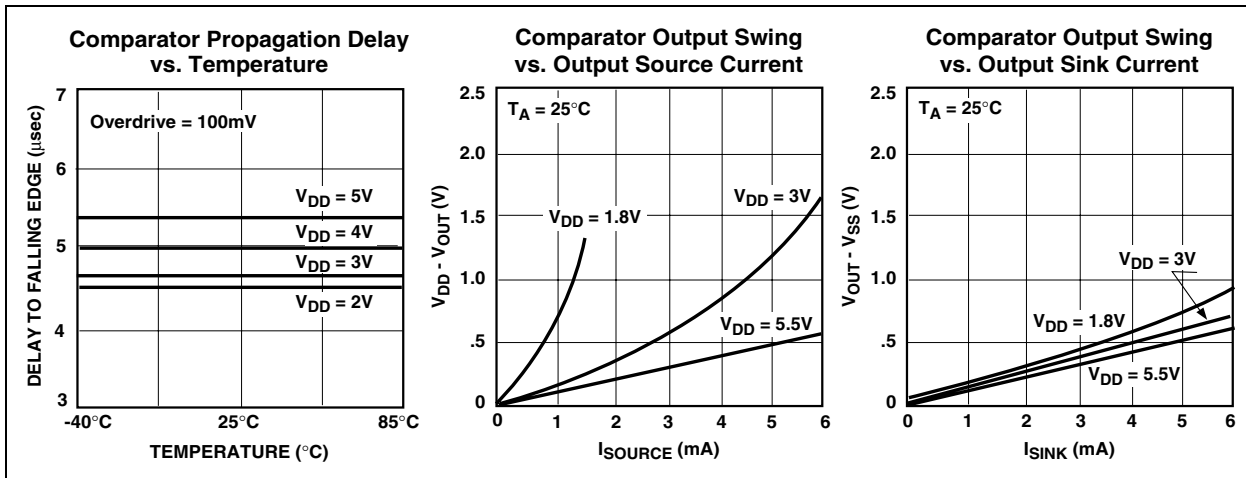
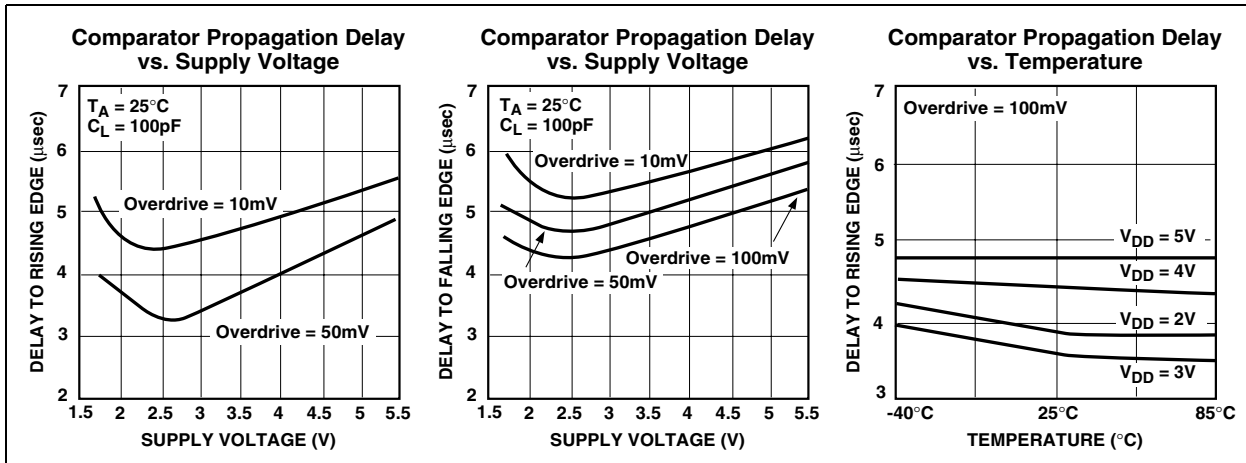

FIGURE 4-3: COMPARATOR EXTERNAL HYSTERESIS CONFIGURATION



5.0 TYPICAL CHARACTERISTICS

Note: The graphs and tables provided following this note are a statistical summary based on a limited number of samples and are provided for informational purposes only. The performance characteristics listed herein are not tested or guaranteed. In some graphs or tables, the data presented may be outside the specified operating range (e.g., outside specified power supply range) and therefore outside the warranted range.



5.0 TYPICAL CHARACTERISTICS (CONTINUED)

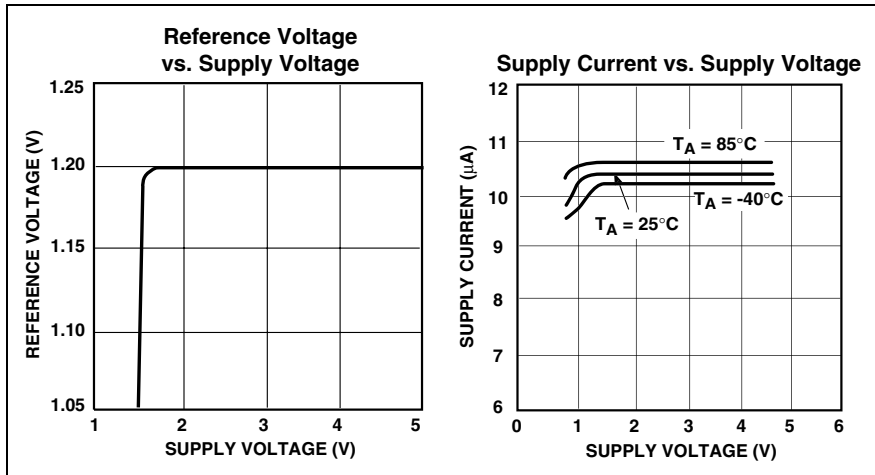

TC1028

6.0 PACKAGING INFORMATION

6.1 Package Marking Information

Package marking data not available at this time.

6.2 Taping Form

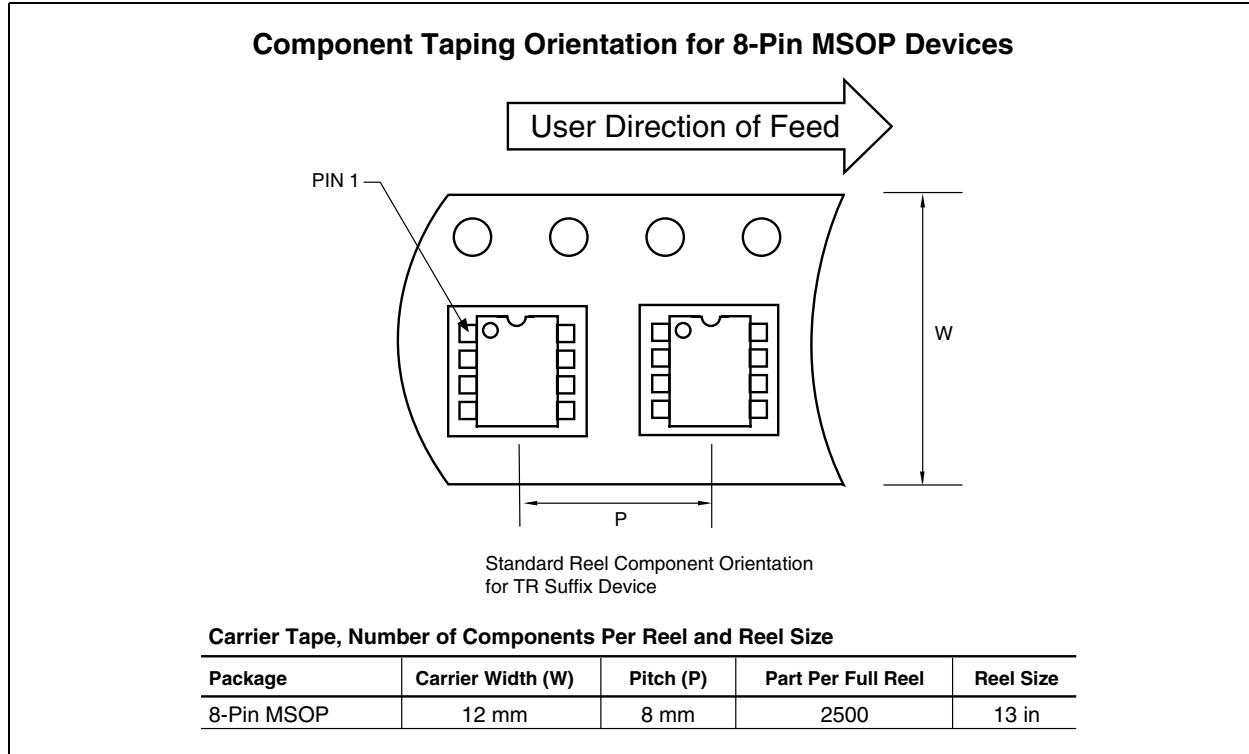

6.3 Package Dimensions

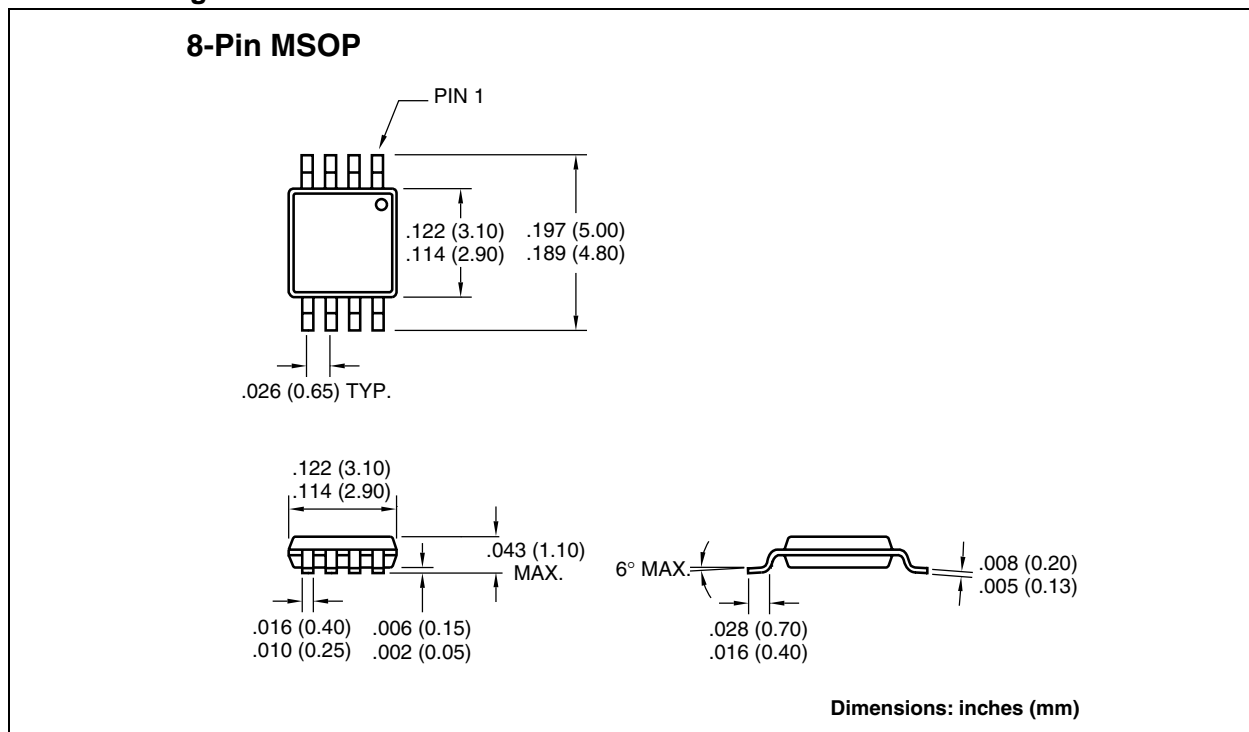

Sales and Support

Data Sheets

Products supported by a preliminary Data Sheet may have an errata sheet describing minor operational differences and recommended workarounds. To determine if an errata sheet exists for a particular device, please contact one of the following:

1. Your local Microchip sales office
2. The Microchip Corporate Literature Center U.S. FAX: (480) 792-7277
3. The Microchip Worldwide Site (www.microchip.com)

Please specify which device, revision of silicon and Data Sheet (include Literature #) you are using.

New Customer Notification System

Register on our web site (www.microchip.com/cn) to receive the most current information on our products.

TC1028

NOTES:

Information contained in this publication regarding device applications and the like is intended through suggestion only and may be superseded by updates. It is your responsibility to ensure that your application meets with your specifications. No representation or warranty is given and no liability is assumed by Microchip Technology Incorporated with respect to the accuracy or use of such information, or infringement of patents or other intellectual property rights arising from such use or otherwise. Use of Microchip's products as critical components in life support systems is not authorized except with express written approval by Microchip. No licenses are conveyed, implicitly or otherwise, under any intellectual property rights.

Trademarks

The Microchip name and logo, the Microchip logo, FilterLab, KEELOQ, microID, MPLAB, PIC, PICmicro, PICMASTER, PICSTART, PRO MATE, SEEVAL and The Embedded Control Solutions Company are registered trademarks of Microchip Technology Incorporated in the U.S.A. and other countries.

dsPIC, ECONOMONITOR, FanSense, FlexROM, fuzzyLAB, In-Circuit Serial Programming, ICSP, ICEPIC, microPort, Migratable Memory, MPASM, MPLIB, MPLINK, MPSIM, MXDEV, PICC, PICDEM, PICDEM.net, rfPIC, Select Mode and Total Endurance are trademarks of Microchip Technology Incorporated in the U.S.A.

Serialized Quick Turn Programming (SQTP) is a service mark of Microchip Technology Incorporated in the U.S.A.

All other trademarks mentioned herein are property of their respective companies.

© 2002, Microchip Technology Incorporated, Printed in the U.S.A., All Rights Reserved.

 Printed on recycled paper.

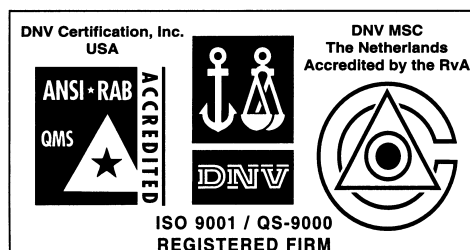

Microchip received QS-9000 quality system certification for its worldwide headquarters, design and wafer fabrication facilities in Chandler and Tempe, Arizona in July 1999 and Mountain View, California in March 2002. The Company's quality system processes and procedures are QS-9000 compliant for its PICmicro® 8-bit MCUs, KEELOQ® code hopping devices, Serial EEPROMs, microperipherals, non-volatile memory and analog products. In addition, Microchip's quality system for the design and manufacture of development systems is ISO 9001 certified.



MICROCHIP

WORLDWIDE SALES AND SERVICE

AMERICAS

Corporate Office

2355 West Chandler Blvd.
Chandler, AZ 85224-6199
Tel: 480-792-7200 Fax: 480-792-7277
Technical Support: 480-792-7627
Web Address: <http://www.microchip.com>

Rocky Mountain

2355 West Chandler Blvd.
Chandler, AZ 85224-6199
Tel: 480-792-7966 Fax: 480-792-7456

Atlanta

500 Sugar Mill Road, Suite 200B
Atlanta, GA 30350
Tel: 770-640-0034 Fax: 770-640-0307

Boston

2 Lan Drive, Suite 120
Westford, MA 01886
Tel: 978-692-3848 Fax: 978-692-3821

Chicago

333 Pierce Road, Suite 180
Itasca, IL 60143
Tel: 630-285-0071 Fax: 630-285-0075

Dallas

4570 Westgrove Drive, Suite 160
Addison, TX 75001
Tel: 972-818-7423 Fax: 972-818-2924

Detroit

Tri-Atria Office Building
32255 Northwestern Highway, Suite 190
Farmington Hills, MI 48334
Tel: 248-538-2250 Fax: 248-538-2260

Kokomo

2767 S. Albright Road
Kokomo, Indiana 46902
Tel: 765-864-8360 Fax: 765-864-8387

Los Angeles

18201 Von Karman, Suite 1090
Irvine, CA 92612
Tel: 949-263-1888 Fax: 949-263-1338

New York

150 Motor Parkway, Suite 202
Hauppauge, NY 11788
Tel: 631-273-5305 Fax: 631-273-5335

San Jose

Microchip Technology Inc.
2107 North First Street, Suite 590
San Jose, CA 95131
Tel: 408-436-7950 Fax: 408-436-7955

Toronto

6285 Northam Drive, Suite 108
Mississauga, Ontario L4V 1X5, Canada
Tel: 905-673-0699 Fax: 905-673-6509

ASIA/PACIFIC

Australia

Microchip Technology Australia Pty Ltd
Suite 22, 41 Rawson Street
Epping 2121, NSW
Australia
Tel: 61-2-9868-6733 Fax: 61-2-9868-6755

China - Beijing

Microchip Technology Consulting (Shanghai)
Co., Ltd., Beijing Liaison Office
Unit 915
Bei Hai Wan Tai Bldg.
No. 6 Chaoyangmen Beidajie
Beijing, 100027, No. China
Tel: 86-10-85282100 Fax: 86-10-85282104

China - Chengdu

Microchip Technology Consulting (Shanghai)
Co., Ltd., Chengdu Liaison Office
Rm. 2401, 24th Floor,
Ming Xing Financial Tower
No. 88 TIDU Street
Chengdu 610016, China
Tel: 86-28-6766200 Fax: 86-28-6766599

China - Fuzhou

Microchip Technology Consulting (Shanghai)
Co., Ltd., Fuzhou Liaison Office
Unit 28F, World Trade Plaza
No. 71 Wusi Road
Fuzhou 350001, China
Tel: 86-591-7503506 Fax: 86-591-7503521

China - Shanghai

Microchip Technology Consulting (Shanghai)
Co., Ltd.
Room 701, Bldg. B
Far East International Plaza
No. 317 Xian Xia Road
Shanghai, 200051
Tel: 86-21-6275-5700 Fax: 86-21-6275-5060

China - Shenzhen

Microchip Technology Consulting (Shanghai)
Co., Ltd., Shenzhen Liaison Office
Rm. 1315, 13/F, Shenzhen Kerry Centre,
Renminnan Lu
Shenzhen 518001, China
Tel: 86-755-2350361 Fax: 86-755-2366086

Hong Kong

Microchip Technology Hongkong Ltd.
Unit 901-6, Tower 2, Metroplaza
223 Hing Fong Road
Kwai Fong, N.T., Hong Kong
Tel: 852-2401-1200 Fax: 852-2401-3431

India

Microchip Technology Inc.
India Liaison Office
Divyasree Chambers
1 Floor, Wing A (A3/A4)
No. 11, O'Shaugnessey Road
Bangalore, 560 025, India
Tel: 91-80-2290061 Fax: 91-80-2290062

Japan

Microchip Technology Japan K.K.
Benex S-1 6F
3-18-20, Shinyokohama
Kohoku-Ku, Yokohama-shi
Kanagawa, 222-0033, Japan
Tel: 81-45-471-6166 Fax: 81-45-471-6122

Korea

Microchip Technology Korea
168-1, Youngbo Bldg. 3 Floor
Samsung-Dong, Kangnam-Ku
Seoul, Korea 135-882
Tel: 82-2-554-7200 Fax: 82-2-558-5934

Singapore

Microchip Technology Singapore Pte Ltd.
200 Middle Road
#07-02 Prime Centre
Singapore, 188980
Tel: 65-6334-8870 Fax: 65-6334-8850

Taiwan

Microchip Technology Taiwan
11F-3, No. 207
Tung Hua North Road
Taipei, 105, Taiwan
Tel: 886-2-2717-7175 Fax: 886-2-2545-0139

EUROPE

Denmark

Microchip Technology Nordic ApS
Regus Business Centre
Lautrup høj 1-3
Ballerup DK-2750 Denmark
Tel: 45 4420 9895 Fax: 45 4420 9910

France

Microchip Technology SARL
Parc d'Activite du Moulin de Massy
43 Rue du Saule Trapu
Batiment A - 1er Etage
91300 Massy, France
Tel: 33-1-69-53-63-20 Fax: 33-1-69-30-90-79

Germany

Microchip Technology GmbH
Gustav-Heinemann Ring 125
D-81739 Munich, Germany
Tel: 49-89-627-144 0 Fax: 49-89-627-144-44

Italy

Microchip Technology SRL
Centro Direzionale Colleoni
Palazzo Taurus 1 V. Le Colleoni 1
20041 Agrate Brianza
Milan, Italy
Tel: 39-039-65791-1 Fax: 39-039-6899883

United Kingdom

Arizona Microchip Technology Ltd.
505 Eskdale Road
Winnersh Triangle
Wokingham
Berkshire, England RG41 5TU
Tel: 44 118 921 5869 Fax: 44-118 921-5820

03/01/02

