



RB-TK2051

CLASS-T DIGITAL AUDIO AMPLIFIER 2 CHANNEL TK2051 EVALUATION BOARD

Technical Information- Board Rev. 1.4

Revision 1.0 – April 2002

GENERAL DESCRIPTION

The RB-TK2051 Revision 1.4 is a stereo 50W per channel audio amplifier designed to provide a simple and straightforward environment for the evaluation of the TK2051 amplifier as well as a small footprint reference design (3.2" X 2"). For additional documentation on the TK2051, see the TK2051 Data Sheet.

APPLICATIONS

- 6Ω and 8 Ω stereo
- 4 Ω mono (parallel operation)
- Home Theater Receivers
- Multi-channel Distribution
- Powered DVD Systems
- Mini/Micro Systems

BENEFITS

- More power per cubic inch for 50W/Channel design
- Simplifies thermal management
- Signal Quality comparable to high quality, linear amplifiers
- Simple building block for multi-channel design

FEATURES

- High Continuous Power*: 46W @ 6Ω
50W @ 8Ω
- * 1/8 power for 1 hour followed by full power for 5 minutes.
- Low Noise Floor: <135uV A-weighted
- Low Distortion: .005% THD+N, 20W, 6Ω
.005% THD+N, 30W, 8Ω
- High Efficiency: 85% @ 46W, 6Ω
89% @ 59W, 8Ω
- Over-Current Protection
- Over and Under Voltage Protection
- Over Temperature Protection

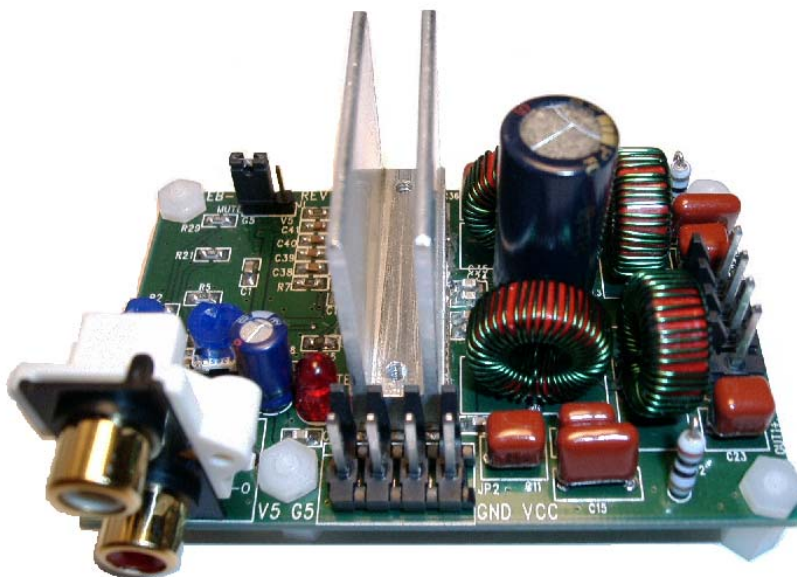

PERFORMANCE CHARACTERISTICS

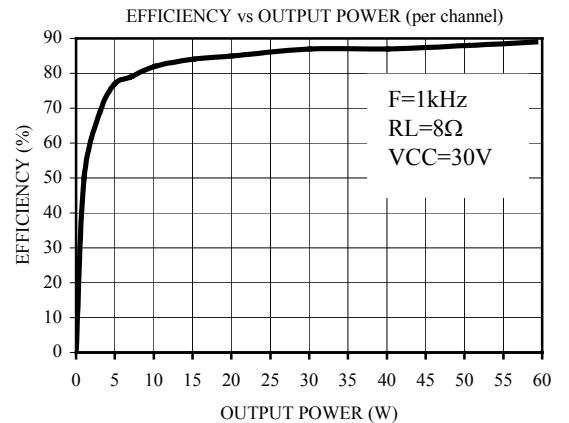
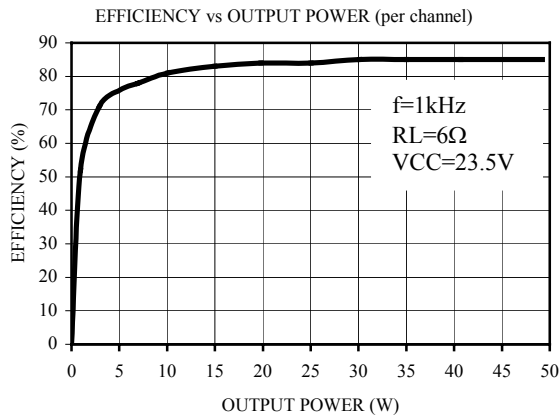
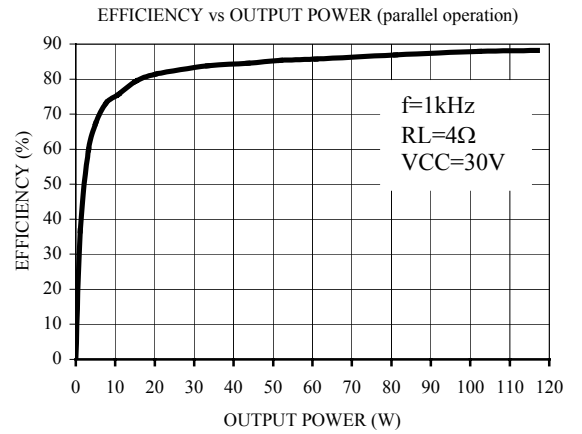
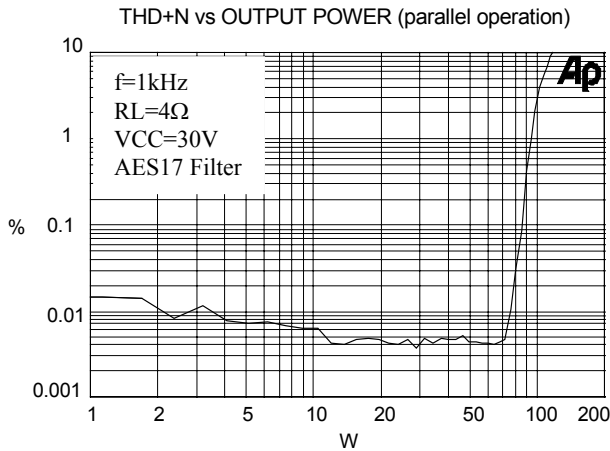
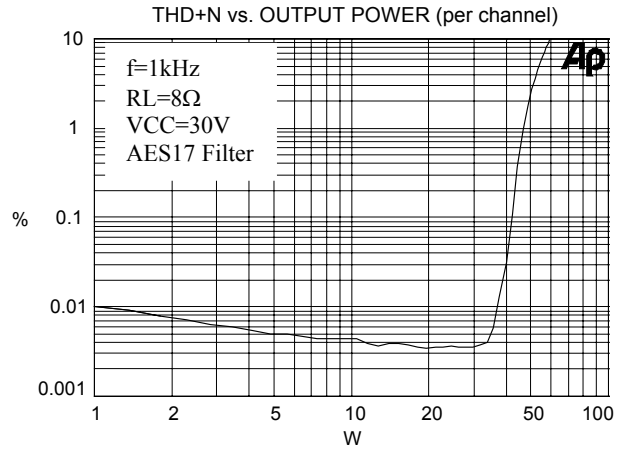
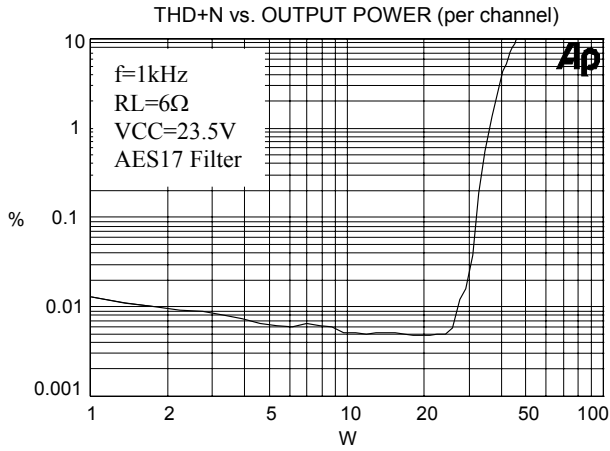

OPERATING INSTRUCTIONS

BOARD CONNECTION DIAGRAM

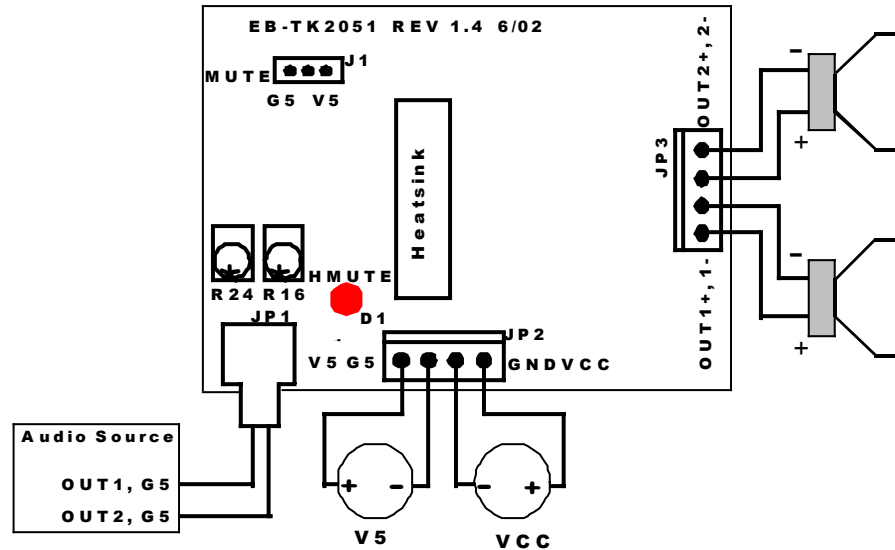

POWER SUPPLIES

Two external power supplies are required to operate the RB-TK2051: VCC (referenced to GND), and V5 (referenced to G5). The V5 ground (G5) must be kept separate from the VCC ground (GND). GND and G5 are joined at a common point on the RB-TK2051 with a 0Ω resistor (R1).

The Minimum and Maximum VCC supply voltages are +10V and +30V, respectively.

The V5 supply voltage is 5V. Please see the TK2051 Data Sheet for Minimum and Maximum values.

The VCC and V5 power supply connection (JP2) is a standard 4 pin, .156" Molex header. Please refer to the Board Connection Diagram for the connector locations on the RB-TK2051.

OUTPUT

The output connection (JP3) for the RB-TK2051 is a standard 4 pin, .156" Molex header. The output of the TK2051 is differential; therefore each output has a positive output (OUT1+ and OUT2+) and a NEGATIVE OUTPUT (OUT1- AND OUT2-).

Please refer to the Board Connection Diagram for the connector locations on the RB-TK2051.

INPUT

The input connection for the RB-TK2051 is a dual RCA connector (JP1). The RCA connector is labeled IN1 and IN2 on the bottom of the PCB. These inputs share a common ground referenced to G5. Please refer to the Board Connection Diagram for the connector locations on the RB-TK2051.

JUMPER SETTINGS

There is a 3-pin header for the MUTE (J1) control of the TK2051. With the jumper placed in the G5 position the part is un-muted. When the jumper is placed in the V5 position the mute pin is pulled high (5V) and the amplifier is muted. Please refer to the Board Connection Diagram for the connector locations on the RB-TK2051.

INDICATOR LED'S

The RB-TK2051 has an LED labeled HMUTE (D1). The LED will glow red and both outputs are muted when a fault occurs or the MUTE header is set to V5. Please refer to the TK2051 Data Sheet for a complete description of HMUTE. Please refer to the Board Connection Diagram for the LED locations on the RB-TK2051.

OUTPUT OFFSET NULL

There are two potentiometers, R16 (Channel 1) and R24 (Channel 2) that are used to manually trim the output offset to 0Vdc. Please refer to the Board Connection Diagram for the potentiometer locations on the RB-TK2051. The Evaluation board is shipped each channels offsets nulled within +/-10mV.

GAIN SETTING

The gain of the RB-TK2051 Rev 1.3 is set to 15V/V. The gain of the TK2051 is the product of the TC2000 (control stage) gain and the TP2051 (power stage) gain. The control stage gain is set to unity. Before changing the gain of the RB-TK2051, please refer to the Amplifier Gain section of the TK2051 Data Sheet.

PERFORMING MEASUREMENTS ON THE RB-TK2051 Rev 1.4:

The TK2051 operates by generating a high frequency switching signal based on the audio input. This signal is sent through a low-pass filter that recovers an amplified version of the audio input. The frequency of the switching pattern is spread spectrum in nature and typically varies between 100kHz and 1MHz, which is well above the 20Hz – 20kHz audio band. The pattern itself does not alter or distort the audio input signal, but it does introduce some inaudible components.

The measurements of certain performance parameters, particularly noise related specifications such as THD+N, are significantly affected by the design of the low-pass filter used on the output as well as the bandwidth setting of the measurement instrument used. Unless the filter has a very sharp roll-off just beyond the audio band or the bandwidth of the measurement instrument is limited, some of the inaudible noise components introduced by the TK2051 amplifier switching pattern will degrade the measurement by including out of band (audio) energy.

One feature of the TK2051 is that it does not require large multi-pole filters to achieve excellent performance in listening tests, usually a more critical factor than performance measurements. Though using a multi-pole filter may remove high-frequency noise and improve THD+N type measurements (when they are made with wide-bandwidth measuring equipment), these same filters degrade frequency response. The RB-TK2051 has a simple two-pole output filter with excellent performance in listening tests. (See Application Note 4 for additional information on bench testing)

Contact Information

TRIPATH TECHNOLOGY, INC

2560 Orchard Parkway, San Jose, CA 95131

408.750.3000 - P

408.750.3001 - F

For more Sales Information, please visit us @ www.tripath.com/contact.htm

For more Technical Information, please visit us @ www.tripath.com/data.htm

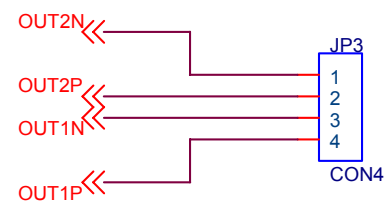
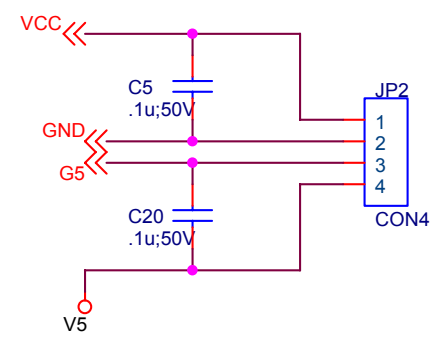
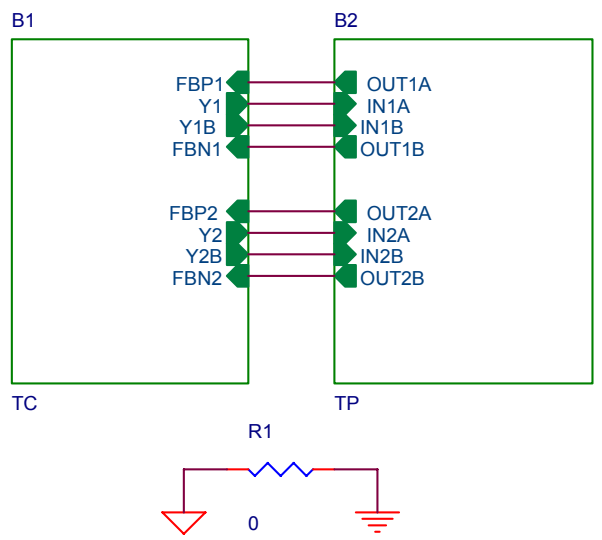
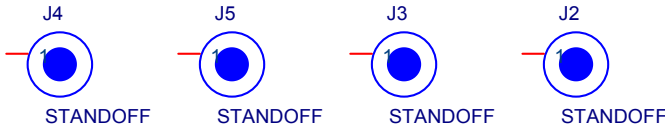

Title		
TK2051 EVAL BOARD		
Size	Document Number	Rev
A	<Doc>	1.4
Date:	Monday, July 22, 2002	Sheet 1 of 3

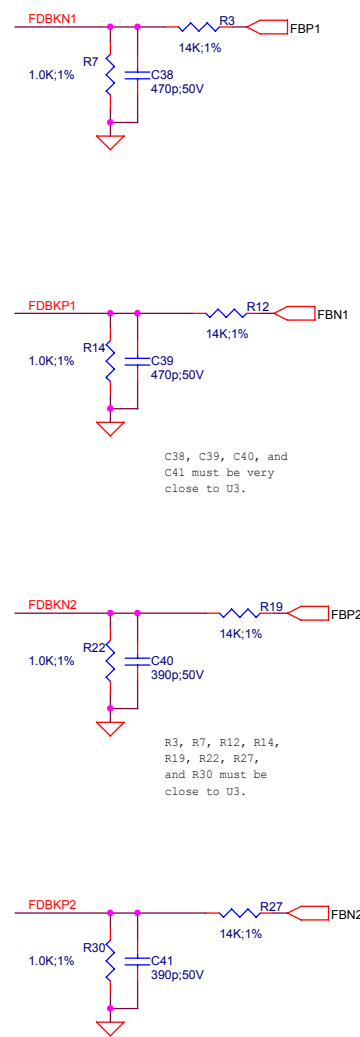
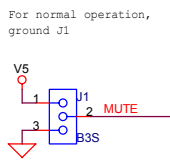
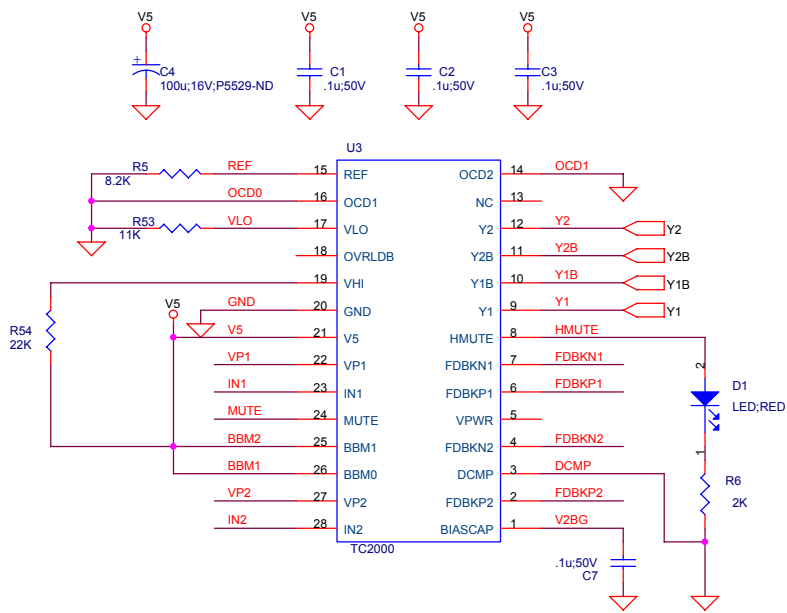
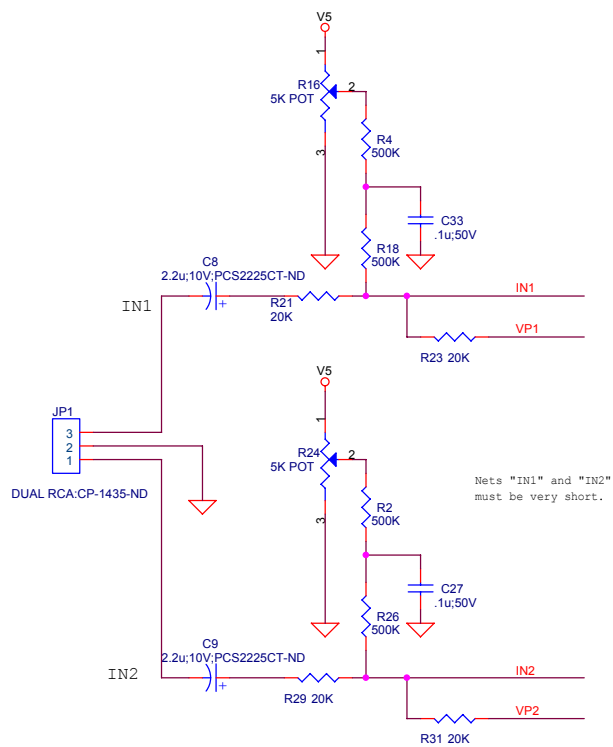

Title		
TK2051 EVAL BOARD		
Size B	Document Number <Doc>	Rev 1.4
Date:	Monday, July 22, 2002	Sheet 2 of 3

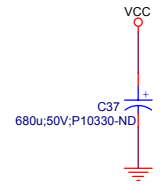
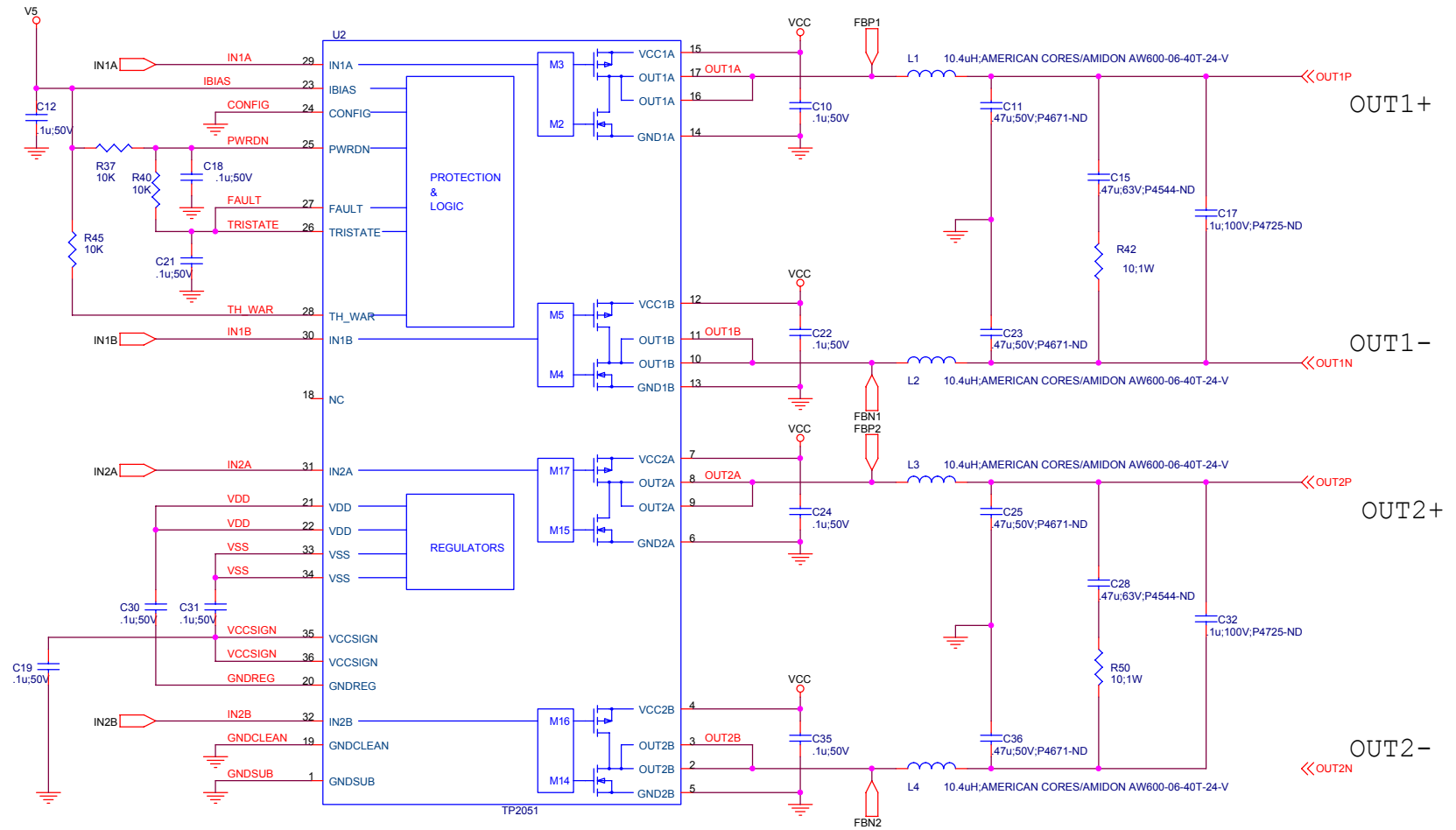

Title		
TK2051 EVAL BOARD		
Size	Document Number	Rev
B	<Doc>	1.4
Date:	Monday, July 22, 2002	Sheet 3 of 3

TK2051 EVAL BOARD Revised 6/20/02
 REVISION 1.4

Item	Quantity	Reference	Part;Digi-Key number	Package Info.	Notes:
1	18	C1,C2,C3,C5,C7,C10,C12, C18,C19,C20,C21,C22,C24, C27,C30,C31,C33,C35	.1u;50V	CAP0805	
2	1	C4	100u;16V;P5529-ND	Thru-hole	
3	2	C8,C9	2.2u;10V;PCS2225CT-ND	CAP3612	
4	4	C11,C23,C25,C36	.47u;50V;P4671-ND	Thru-hole	
5	2	C28,C15	.47u;63V;P4544-ND	Thru-hole	
6	2	C17,C32	.1u;100V;P4725-ND	Thru-hole	
7	1	C37	680u;50V;P10330-ND	Thru-hole	
8	2	C38,C39	470p;50V	CAP0805	
9	2	C40,C41	390p;50V	CAP0805	
10	1	D1	LED;RED		
11	1	JP1	DUAL RCA;CP-1435-ND		
12	2	JP2,JP3	CON4	4pin, 156Mil	
13	1	J1	B3S	3pin, 100Mil	
14	4	J2,J3,J4,J5	STANDOFF		
15	4	L1,L2,L3,L4	10.4uH		AMERICAN CORES/AMIDON AW600-06-40T-24-V
16	1	R1	0	RES0805	
17	4	R2,R4,R18,R26	500K	RES0805	
18	4	R3,R12,R19,R27	14K;1%	RES0805	
19	1	R5	8.2K	RES0805	
20	1	R6	2K	RES0805	
21	4	R7,R14,R22,R30	1.0K;1%	RES0805	
22	2	R16,R24	5K POT;3306P-502-ND		
23	4	R21,R23,R29,R31	20K	RES0805	
24	3	R37,R40,R45	10K	RES0805	
25	2	R50,R42	10;1W;P10W-1BK-ND	Thru-hole	
26	1	R53	11K	RES0805	
27	1	R54	22K	RES0805	
28	1	U2	TP2051		
29	1	U3	TC2000		

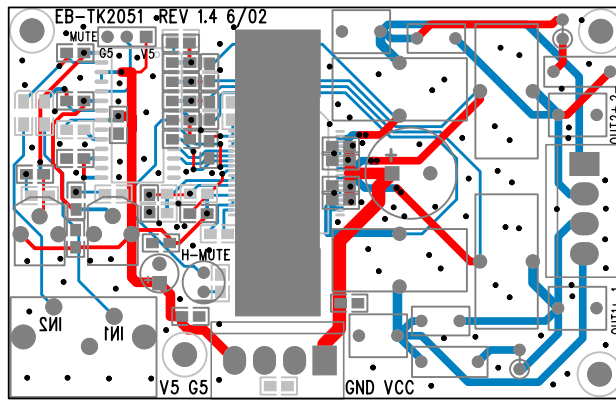

FABRICATION NOTES
DOUBLE SIDED BOARD
MATERIAL: .062 FR-4
2 OZ COPPER, ALL LAYERS

VIEWED FROM TOP SIDE
COMPOSITE DRAWING
Top Trace RED
Bottom Trace BLUE
Top Component DARK GRAY
Bottom Component LIGHT GRAY

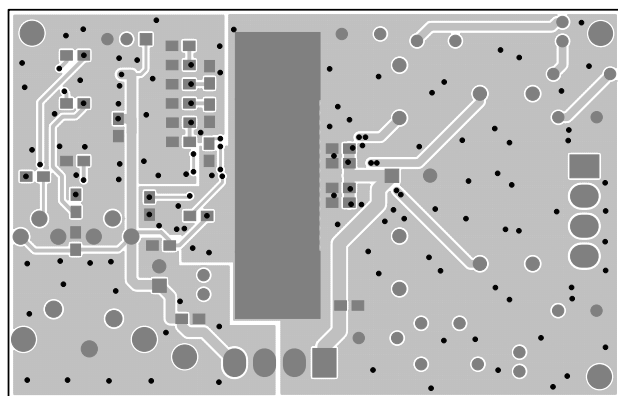

FABRICATION NOTES
DOUBLE SIDED BOARD
MATERIAL: .062 FR-4
2 OZ COPPER, ALL LAYERS

VIEWED FROM TOP SIDE
TOP SIDE ETCH

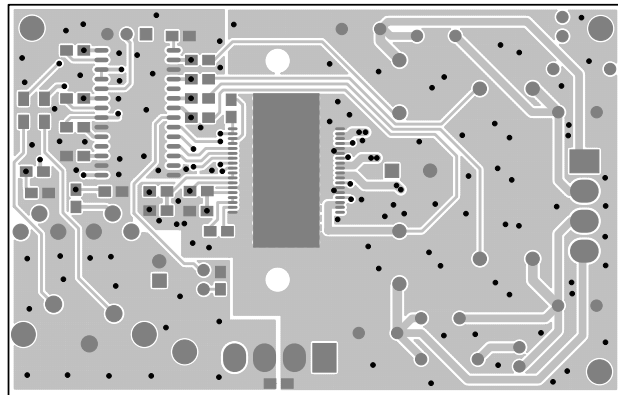

FABRICATION NOTES
DOUBLE SIDED BOARD
MATERIAL: .062 FR-4
2 OZ COPPER, ALL LAYERS

VIED FROM TOP SIDE
BOTTOM SIDE ETCH

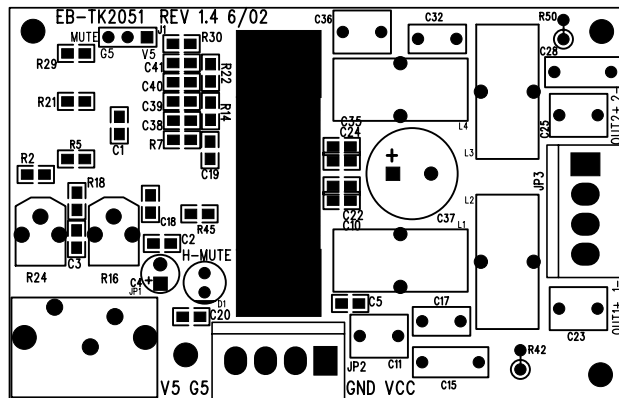

FABRICATION NOTES
 DOUBLE SIDED BOARD
 MATERIAL: .062 FR-4
 2 OZ COPPER, ALL LAYERS

VIEWED FROM TOP SIDE
 SILKSCREEN TOP

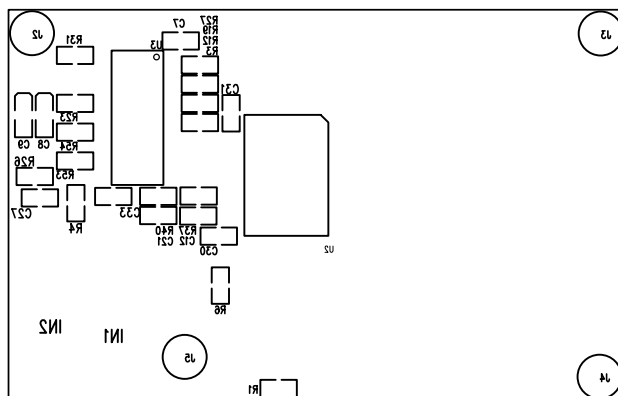

FABRICATION NOTES
 DOUBLE SIDED BOARD
 MATERIAL: .062 FR-4
 2 OZ COPPER, ALL LAYERS

VIED FROM TOP SIDE
 SILKSCREEN BOTTOM