

# Solid-Electrolyte TANTALEX<sup>®</sup> Capacitors

## Extended Capacitance Values, Hermetically-Sealed

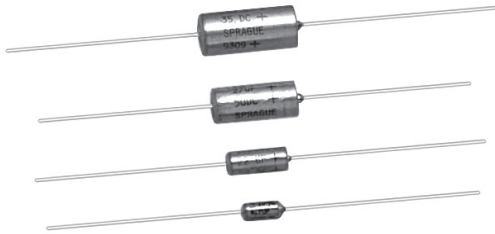

### FEATURES

- High capacitance and small size
- Low leakage current and low dissipation factor
- Exceptional operating stability
- Hermetically-sealed, cylindrical, metal-case
- The military equivalent to the 152D is the CSR23 which is qualified to MIL-C-39003/03
- Provide proven reliability in a wide variety of high performance military, industrial and commercial markets

### PERFORMANCE CHARACTERISTICS

**Operating Temperature:** - 55°C to + 85°C. (To + 125°C with voltage derating.)

**Capacitance Tolerance:** At 120 Hz, + 25°C. ± 20% and ±10% standard. ± 5% available as special.

**Dissipation Factor:** At 120 Hz, + 25°C. Dissipation factor, as determined from the expression  $2\pi fRC$ , shall not exceed the values listed in the Standard Ratings Tables.

**DC Leakage Current (DCL Max.):**

**At + 25°C:** Leakage current shall not exceed the values listed in the Standard Ratings Tables.

**At + 85°C:** Leakage current shall not exceed 10 times the values listed in the Standard Ratings Tables.

**At + 125°C:** Leakage current shall not exceed 12 times the values listed in the Standard Ratings Tables.

**Life Test:** Capacitors shall withstand rated DC voltage applied at + 85°C for 2000 hours or derated DC voltage applied at + 125°C for 1000 hours.

Following the life test:

1. DCL shall not exceed 125% of the initial requirements. In no case need the leakage current be less than 2µA.
2. Dissipation Factor shall meet the initial requirement.
3. Change in capacitance shall not exceed ± 5%.

### ORDERING INFORMATION

152D	106	X0	006	A	2	T
MODEL	CAPACITANCE	CAPACITANCE TOLERANCE	DC VOLTAGE RATING AT + 85°C	CASE CODE	STYLE NUMBER	PACKAGING
This is expressed in picofarads. The first two digits are the significant figures. The third is the number of zeros to follow.		X0 = ± 20% X9 = ± 10% *X5 = ± 5% *Special order	This is expressed in volts. To complete the three-digit block, zeros precede the voltage rating.	See Ratings and Case Codes Table.	2 = Insulated sleeve.	T = Tape and Reel

### DIMENSIONS in inches [millimeters]

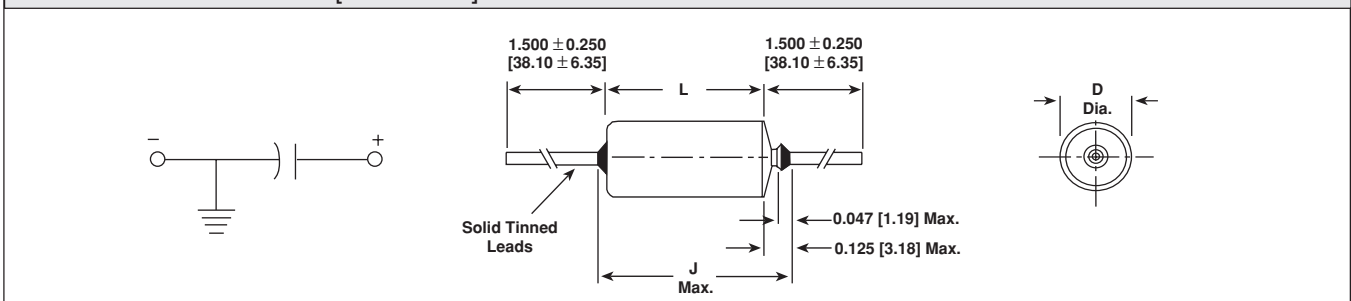

CASE CODE	WITH INSULATING SLEEVE*		J (MAX.)	LEAD SIZE	
	D	L		AWG NO.	NOMINAL DIA.
A	0.135 ± 0.016 [3.43 ± 0.41]	0.286 ± 0.031 [7.26 ± 0.79]	0.422 [10.72]	24	0.020 [0.51]
B	0.185 ± 0.016 [4.70 ± 0.41]	0.474 ± 0.031 [12.04 ± 0.79]	0.610 [15.49]	24	0.020 [0.51]
R	0.289 ± 0.016 [7.34 ± 0.41]	0.686 ± 0.031 [17.42 ± 0.79]	0.822 [20.88]	22	0.025 [0.64]
S	0.351 ± 0.016 [8.92 ± 0.41]	0.786 ± 0.031 [19.96 ± 0.79]	0.922 [23.42]	22	0.025 [0.64]

\*When a shrink-fitted insulation is used, it shall lap over the ends of the capacitor body.



Solid-Electrolyte TANTALEX<sup>®</sup> Capacitors  
Extended Capacitance Values, Hermetically-Sealed

Vishay Sprague

<b>STANDARD RATINGS</b>					
CAPACITANCE ( $\mu$ F)	CASE CODE	PART NUMBER* CAP. TOL. $\pm$ 20%	PART NUMBER* CAP. TOL. $\pm$ 10%	MAX. DCL @ + 25°C ( $\mu$ A)	MAX. DF @ + 25°C 120 Hz (%)
<b>6 WVDC @ + 85°C, SURGE = 8 V . . . 4 WVDC @ + 125°C, SURGE = 5 V</b>					
10	A	152D106X0006A2	152D106X9006A2	1.0	6
12	A	—	152D126X9006A2	1.0	6
15	A	152D156X0006A2	152D156X9006A2	1.0	6
68	B	152D686X0006B2	152D686X9006B2	3.0	6
82	B	—	152D826X9006B2	3.0	6
100	B	152D107X0006B2	152D107X9006B2	6.0	6
330	R	152D337X0006R2	152D337X9006R2	10.0	8
390	R	—	152D397X9006R2	10.0	8
470	R	152D477X0006R2	152D477X9006R2	10.0	8
560	S	—	152D567X9006S2	20.0	10
680	S	152D687X0006S2	152D687X9006S2	20.0	10
820	S	—	152D827X9006S2	20.0	10
1000	S	152D108X0006S2	152D108X9006S2	20.0	10
<b>10 WVDC @ + 85°C, SURGE = 13 V . . . 7 WVDC @ + 125°C, SURGE = 9 V</b>					
5.6	A	—	152D565X9010A2	1.0	4
6.8	A	152D685X0010A2	152D685X9010A2	1.0	6
8.2	A	—	152D825X9010A2	1.2	6
10	A	152D106X0010A2	152D106X9010A2	1.2	6
47	B	152D476X0010B2	152D476X9010B2	4.0	6
56	B	—	152D566X9010B2	5.0	6
68	B	152D686X0010B2	152D686X9010B2	6.0	6
82	B	—	152D826X9010B2	7.0	6
150	R	152D157X0010R2	152D157X9010R2	8.0	8
180	R	—	152D187X9010R2	8.0	8
220	R	152D227X0010R2	152D227X9010R2	12.0	8
270	R	—	152D277X9010R2	13.0	8
330	S	152D337X0010S2	152D337X9010S2	16.0	8
390	S	—	152D397X9010S2	16.0	10
470	S	152D477X0010S2	152D477X9010S2	16.0	10
560	S	—	152D567X9010S2	20.0	10
<b>15 WVDC @ + 85°C, SURGE = 20 V . . . 10 WVDC @ + 125°C, SURGE = 12 V</b>					
3.9	A	—	152D395X9015A2	1.0	4
4.7	A	152D475X0015A2	152D475X9015A2	1.0	4
5.6	A	—	152D565X9015A2	1.3	4
6.8	A	152D685X0015A2	152D685X9015A2	1.3	6
27	B	—	152D276X9015B2	3.0	6
33	B	152D336X0015B2	152D336X9015B2	5.0	6
39	B	—	152D396X9015B2	5.0	6
82	R	—	152D826X9015R2	8.0	6

\*Insert capacitance tolerance code "X5"; for  $\pm$  5% units (special order).



<b>STANDARD RATINGS</b>					
CAPACITANCE ( $\mu$ F)	CASE CODE	PART NUMBER* CAP. TOL. $\pm$ 20%	PART NUMBER* CAP. TOL. $\pm$ 10%	MAX. DCL @ + 25°C ( $\mu$ A)	MAX. DF @ + 25°C 120 Hz (%)
<b>15 WVDC @ + 85°C, SURGE = 20 V . . . 10 WVDC @ + 125°C, SURGE = 12 V</b>					
100	R	152D107X0015R2	152D107X9015R2	10.0	8
120	R	—	152D127X9015R2	10.0	8
150	R	152D157X0015R2	152D157X9015R2	15.0	8
180	R	—	152D187X9015R2	15.0	8
220	S	152D227X0015S2	152D227X9015S2	20.0	8
270	S	—	152D277X9015S2	20.0	8
330	S	152D337X0015S2	152D337X9015S2	20.0	8
<b>20 WVDC @ + 85°C, SURGE = 26 V . . . 13 WVDC @ + 125°C, SURGE = 16 V</b>					
2.7	A	—	152D275X9020A2	0.8	4
3.3	A	152D335X0020A2	152D335X9020A2	1.0	4
3.9	A	—	152D395X9020A2	1.2	4
4.7	A	152D475X0020A2	152D475X9020A2	1.2	4
18	B	—	152D186X9020B2	3.0	4
22	B	152D226X0020B2	152D226X9020B2	3.0	4
27	B	—	152D276X9020B2	4.0	4
56	R	—	152D566X9020R2	7.0	6
68	R	152D686X0020R2	152D686X9020R2	8.0	6
82	R	—	152D826X9020R2	10.0	6
100	R	152D107X0020R2	152D107X9020R2	12.0	6
120	R	—	152D127X9020R2	12.0	6
150	S	152D157X0020S2	152D157X9020S2	15.0	8
180	S	—	152D187X9020S2	15.0	8
220	S	152D227X0020S2	152D227X9020S2	15.0	8
<b>30 WVDC @ + 85°C, SURGE = 39 V . . . 20 WVDC @ + 125°C, SURGE = 26 V</b>					
2.2	A	152D225X0030A2	152D225X9030A2	1.0	4
2.7	A	—	152D275X9030A2	1.0	4
12	B	—	152D126X9030B2	3.0	4
15	B	152D156X0030B2	152D156X9030B2	3.0	4
18	B	—	152D186X9030B2	3.0	4
56	R	—	152D566X9030R2	7.0	6
68	R	152D686X0030R2	152D686X9030R2	7.0	6
82	S	—	152D826X9030S2	10.0	8
100	S	152D107X0030S2	152D107X9030S2	10.0	8
<b>35 WVDC @ + 85°C, SURGE = 46 V . . . 23 WVDC @ + 125°C, SURGE = 28 V</b>					
1.2	A	—	152D125X9035A2	0.6	4
1.5	A	152D155X0035A2	152D155X9035A2	0.8	4
1.8	A	—	152D185X9035A2	1.0	4
8.2	B	—	152D825X9035B2	3.0	4
10	B	152D106X0035B2	152D106X9035B2	3.0	4
27	R	—	152D276X9035R2	7.0	6
33	R	152D336X0035R2	152D336X9035R2	8.0	6
39	R	—	152D396X9035R2	10.0	6
47	R	152D476X0035R2	152D476X9035R2	10.0	6
56	S	—	152D566X9035S2	12.0	6
68	S	152D686X0035S2	152D686X9035S2	12.0	6
82	S	—	152D826X9035S2	30.0	8
100	S	152D107X0035S2	152D107X9035S2	30.0	8
<b>50 WVDC @ + 85°C, SURGE = 65 V . . . 33 WVDC @ + 125°C, SURGE = 40 V</b>					
1.2	A	—	152D125X9050A2	0.6	4
1.5	A	152D155X0050A2	152D155X9050A2	0.8	4
5.6	B	—	152D565X9050B2	2.5	4
6.8	B	152D685X0050B2	152D685X9050B2	2.5	4
22	R	152D226X0050R2	152D226X9050R2	7.0	6
27	R	—	152D276X9050R2	8.0	6
33	S	152D336X0050S2	152D336X9050S2	10.0	6
39	S	—	152D396X9050S2	10.0	6
47	S	152D476X0050S2	152D476X9050S2	10.0	6

\*Insert capacitance tolerance code "X5"; for  $\pm$  5% units (special order).

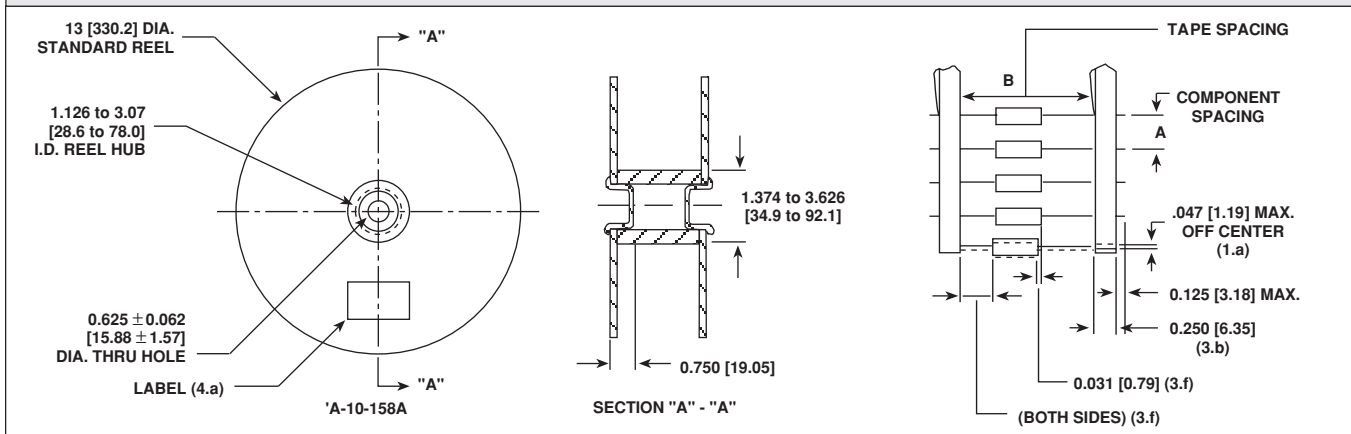
**STANDARD REEL PACKAGING SPECIFICATIONS - MEETS EIA STANDARD RS-296 in inches [millimeters]**

CASE CODE	TYPE 152D UNITS WITH INSULATING SLEEVE			LEAD SIZE		COMPONENT SPACING	TAPE SPACING	UNITS PER REEL
	D	L	J (MAX.)	AWG NO.	NOM. DIA.	A	B	
A	0.135 ± 0.016 [3.43 ± 0.41]	0.286 ± 0.031 [7.26 ± 0.79]	0.422 [10.72]	24	0.020 [0.51]	0.200 ± 0.015 [5.08 ± 0.38]	2.500 ± 0.062 [63.5 ± 1.57]	1000
B	0.185 ± 0.016 [4.70 ± 0.41]	0.474 ± 0.031 [12.04 ± 0.79]	0.610 [15.49]	24	0.020 [0.51]	0.200 ± 0.015 [5.08 ± 0.38]	2.500 ± 0.062 [63.5 ± 1.57]	1000
R	0.289 ± 0.016 [7.34 ± 0.41]	0.686 ± 0.031 [17.42 ± 0.79]	0.822 [20.88]	22	0.025 [0.64]	0.400 ± 0.015 [10.16 ± 0.38]	2.875 ± 0.062 [73.03 ± 1.57]	500
S	0.351 ± 0.016 [8.92 ± 0.41]	0.786 ± 0.031 [19.96 ± 0.79]	0.922 [23.42]	22	0.025 [0.64]	0.400 ± 0.015 [10.16 ± 0.38]	2.875 ± 0.062 [73.03 ± 1.57]	500

**STANDARD REEL PACKAGING INFORMATION**
**1. Component Leads:**

- Component leads shall not be bent beyond 0.047" [1.19mm] maximum from their nominal position when measured from the leading edge of the component lead at the lead egress from the component.
- The 'C' dimension shall be governed by the overall length of the reel packaged component. The distance between flanges shall be 0.125" to 0.250" [3.18mm to 6.35mm] greater than the overall component length.

**2. Orientation:**

- All polarized components must be oriented to one direction. The cathode lead tape shall be a color and the anode lead tape shall be white.

**3. Reeling:**

- Components on any reel shall not represent more than two date codes when date code identification is required.
- Component leads shall be positioned between pairs of 0.250" [6.35mm] tape.
- The disposable reels have hubs and corrugated fiberboard flanges and core or equivalent.
- A minimum of 12" [304.8mm] leader of tape shall be provided before the first and after the last component on the reel.
- 50 or 60 lb. Kraft paper must be wound between layer of components as far as necessary for component protection. Width of paper to be 0.062" to 0.250" [1.57mm to 6.35mm] less than the 'C' dimension of the reel.

- A row of components must be centered between tapes ± 0.047" [1.19mm]. In addition, individual components may deviate from center of component row ± 0.031 [0.79mm].
- Staples shall not be used for splicing. Not more than 4 layers of tape shall be used in any splice area and no tape shall be offset from another by more than 0.031" [0.79mm] non-cumulative. Tape splices shall overlap at least 6" [152.4mm] for butt joints and at least 3" [76.2mm] for lap joints and shall not be weaker than unspliced tape. Universal splicing clips may also be used.
- Quantity per reel shall be controlled so that tape components and cover shall not extend beyond the smallest dimension of the flange (either across flats or diameter). Once the quantity per reel for each part number has been established, future orders for that part number shall be packaged in that quantity. When order or release quantity is less than the established quantity, a standard commercial pack is to be used.
- A maximum of 0.25% of the components per reel quantity may be missing without consecutive missing components.
- Adequate protection must be provided to prevent physical damage to both reel and components during shipment and storage.

**4. Marking:**

- Minimum reel and carton marking shall consist of the following: Customer Part Number, Purchase Order No., Quantity, Package Date, Manufacturer's Name, Electrical Value, Date Code, Vishay Sprague Part Number and Country of Origin.