

1.0 SCOPE

This specification covers the detail requirements for a quad low-power voltage comparator.

It is highly recommended that this data sheet be used as a baseline for new military or aerospace spec control drawings.

1.2 Part Number. The complete part numbers per Table I of this specification follow:

Device	Part Number	Package
A	PM-139AY/883	Y
X	PM-139Y/883	Y
A	PM-139ARC/883	RC

1.2.3 Case Outline.

Letter	Case Outline (Lead finish per MIL-M-38510)
Y	14-pin ceramic dual-in-line package (CERDIP)
RC	20-contact hermetic leadless chip carrier (LCC)

1.3 Absolute Maximum Ratings. ($T_A = 25^\circ\text{C}$, unless otherwise noted)

Supply Voltage, V_+	36V or $\pm 18\text{V}$
Power Dissipation Hermetic DIP	500mW
Derate Above 100°C	10mW/ $^\circ\text{C}$
Differential Input Voltage	36V
Input Voltage	-0.3V to +36V
Output Short-Circuit to Ground	Continuous
Storage Temperature Range	-65°C to $+150^\circ\text{C}$
Operating Temperature Range	-55°C to $+125^\circ\text{C}$
Lead Temperature (Soldering, 60 sec)	$+300^\circ\text{C}$
Input Current ($V_{IN} < -0.3\text{V}$)	50mA

1.5 Thermal Characteristics:

Thermal Resistance, CERDIP (Y) package:

Junction-to-Case (θ_{JC}) = 29°C/W MAX

Junction-to-Ambient (θ_{JA}) = 100°C/W MAX

Thermal Resistance, LCC (RC) package:

Junction-to-Case (θ_{JC}) = 35°C/W MAX

Junction-to-Ambient (θ_{JA}) = 110°C/W MAX

TABLE 1

V+ = 5V, V- = 0V; T_A = 25 °C unless otherwise specified.

Characteristics	Symbol	Special Conditions	PM-139/883				Units
			LIMITS A		LIMITS X		
			Min	Max	Min	Max	
Supply Current (All 4 Comparators)	I _{SY}	V+ = 30V, R _L = ∞	–	2.0	–	2.0	mA
		-55 °C ≤ T _A ≤ +125 °C	–	3.0	–	3.0	mA
Input Offset Voltage	V _{OS}	R _S = 0n, V _O = 1.4V	–	2.0	–	5.0	mV
		-55 °C ≤ T _A ≤ +125 °C	–	4.0	–	9.0	mV
Input Offset Current	I _{OS}	I _{IN} (+) - I _{IN} (-)	–	25	–	25	nA
		-55 °C ≤ T _A ≤ +125 °C	–	100	–	100	nA
Input Bias Current	I _B	I _{IN} (+) or I _{IN} (-)	–	±100	–	±100	nA
		-55 °C ≤ T _A ≤ +125 °C	–	±300	–	±300	nA
Common-Mode Rejection	CMR	R _L ≥ 15kΩ, V+ = 15V	60.5	–	60.5	–	dB
		V _{CM} = 1.5V to 13.5V	60.5	–	60.5	–	dB
Power Supply Rejection	PSR	R _L ≥ 15kΩ, V+ = 15V	60.5	–	60.5	–	dB
		V _{CM} = 1.5V to 13.0V	60.5	–	60.5	–	dB
Output Sink Current	I _{SINK}	-55 °C ≤ T _A ≤ +125 °C	6.0	–	6.0	–	mA
		V _{IN} ⁺ = 0V, V _{IN} ⁻ ≥ 1V	5.0	–	5.0	–	mA
Saturation Voltage	V _{OL}	V _O ≤ 1.5V	–	400	–	400	mV
		I _{SINK} ≤ 4mA	–	700	–	700	mV
		V _{IN} ⁺ = 0V, V _{IN} ⁻ ≥ 1V	–	400	–	400	mV
		I _{SINK} ≤ 4mA	–	700	–	700	mV
		-55 °C ≤ T _A ≤ +125 °C	–	400	–	400	mV

TABLE 1 (Continued)

V+ = 5V, V- = 0V; TA = 25 °C unless otherwise specified.

Characteristics	Symbol	Special Conditions	PM-139/883				Units
			LIMITS A		LIMITS X		
			Min	Max	Min	Max	
Output Leakage Current	ILEAK	VIN+ ≥ 1V, VIN- = 0V VO = 30V	-	500	-	500	nA
		VIN+ ≥ 1V, VIN- = 0V VO = 30V -55 °C ≤ TA ≤ +125 °C	-	1000	-	1000	nA
Large Signal Response Time (Note 2)	t _r Large Signal	VIN = 0V to 5V VREF = 1.4V, VRL = 5V RL = 5.1kΩ	-	700	-	700	ns
Small Signal Response Time (Note 2)	t _r Small Signal	Low to High Transition VRL = 5V, RL = 5.1kΩ 100mV Input Step, 5mV Overdrive	-	5.0	-	5.0	μs
		High to Low Transition VRL = 5V, RL = 5.1kΩ 100mV Input Step, 5mV Overdrive	-	2.5	-	2.5	μs
Common-Mode Voltage Range (Note 1)	CMVR	V+ = 15V	0 to 13.5	-	0 to 13.5	-	V
		V+ = 15V -55 °C ≤ TA ≤ +125 °C	0 to 13.0	-	0 to 13.0	-	V

NOTES:

1. CMVR is guaranteed by V_{OS} and CMR conditions. The input common-mode voltage, or either input signal voltage should not be allowed to go negative by more than 0.3V. The upper end of the common-mode voltage range is V(+) -1.5V, but either or both inputs can go to +30V without damage.
2. Sample tested.

7
COMPARATORS

TABLE 2

PM-139/883

Electrical Test Requirements For Class B Devices

MIL-STD-883 Test Requirements	Subgroups (see Table 3)
Interim Electrical Parameters (pre Burn-In)	1
Final Electrical Test Parameters	1*, 2, 3
Group A Test Requirements	1, 2, 3, 9

* PDA applies to Subgroup 1 only.
No other Subgroups are included in PDA.

TABLE 3

Group A Inspection

V+ = 5V, V- = 0V unless otherwise specified.

Subgroup	Symbol	Special Conditions	PM-139/883				Units
			LIMITS A		LIMITS X		
			Min	Max	Min	Max	
Subgroup 1 T _A = +25°C	I _{SY}	V+ = 30V, R _L = ∞ (Note 1)	--	2.0	--	2.0	mA
	V _{OS}	R _S = 0Ω, V _O = 1.4V	--	2.0	--	5.0	mV
	I _{OS}		--	25	--	25	nA
	I _B		--	±100	--	±100	nA
	CMR	V+ = 15V, R _L = 15kΩ V _{CM} = 1.5V, 13.5V	60.5	--	60.5	--	dB
	PSR	V+ = +5V, +18V	60.5	--	60.5	--	dB
	I _{SINK}	V _{IN+} = 0V, V _{IN-} = 1V V _O = 1.5V	6.0	--	6.0	--	mA
	V _{OL}	I _{SINK} = 4mA V _{IN+} = 0V, V _{IN-} = 1V	--	400	--	400	mV
I _{LEAK}	V _{IN+} = 1V, V _{IN-} = 0V V _O = 30V	--	500	--	500	nA	
Subgroup 2 T _A = +125°C	I _{SY}	V+ = 30V, R _L = ∞ (Note 1)	--	3.0	--	3.0	mA
	V _{OS}	R _S = 0Ω, V _O = 1.4V	--	4.0	--	9.0	mV
	I _{OS}		--	100	--	100	nA
	I _B		--	±300	--	±300	nA

7
COMPARATORS

TABLE 3

Group A Inspection (Continued)

V+ = 5V, V- = 0V unless otherwise specified.

Subgroup	Symbol	Special Conditions	PM-139/883				Units
			LIMITS A		LIMITS X		
			Min	Max	Min	Max	
Subgroup 2 T _A = +125°C (Continued)	CMR	V+ = 15V, R _L = 15kΩ V _{CM} = 1.5V, 13V	60.5	--	60.5	--	dB
	PSR	V+ = +5V, +18V	60.5	--	60.5	--	dB
	I _{SINK}	V _{IN+} = 0V, V _{IN-} = 1V V _O = 1.5V	5	--	5	--	mA
	V _{OL}	I _{SINK} = 4mA V _{IN+} = 0V, V _{IN-} = 1V	--	700	--	700	mV
	I _{LEAK}	V _{IN+} = 0V, V _{IN-} = 0V V _O = 30V	--	1000	--	1000	nA
Subgroup 3 T _A = -55°C	All Tests, Limits and Conditions are the same as for Subgroup 2.						
Subgroup 9 T _A = +25°C	t _r Large Signal	V _{IN} = 0V, 5V V _{REF} = 1.4V, V _{RL} = 5V R _L = 5.1kΩ	--	700	--	700	ns
	t _r Small Signal	Low to High Transition V _{RL} = 5V, R _L = 5.1kΩ 100mV Input Step 5mV Overdrive High to Low Transition V _{RL} = 5V, R _L = 5.1kΩ 100mV Input Step 5mV Overdrive	--	5.0	--	5.0	μs
			--	2.5	--	2.5	μs

NOTES:

1. Total all four comparators.

**3.2.1 Simplified Schematic and Pin Connections.
(ONE COMPARATOR)**

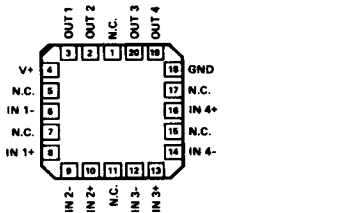
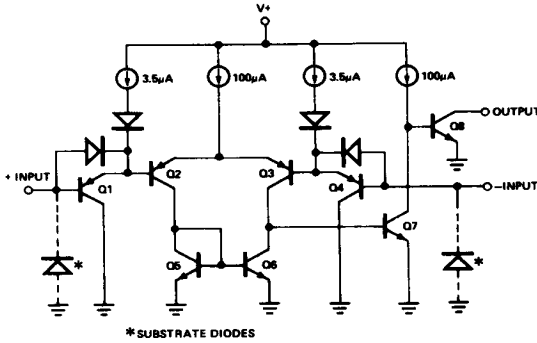

**PM-139ARC/883
LCC-PACKAGE
(RC-Suffix)**

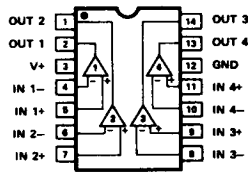

**14-PIN HERMETIC DIP
(Y-Suffix)**

3.2.4 Microcircuit Group Assignment. This microcircuit is covered by microcircuit group 50.

4.2 Life Test/Burn-In Circuit.

