

MS1578

RF & MICROWAVE TRANSISTORS
800-960MHz CELLULAR BASE STATION

Features

- GOLD METALLIZATION
- DESIGNED FOR LINEAR OPERATION HIGH SATURATED POWER CAPABILITY
- POUT = 150 W PEP
- INTERNAL INPUT/OUTPUT MATCHING
- COMMON EMITTER CONFIGURATION
- 8.0dB GAIN @ 900 MHz
- MAX IMD -28dBc @ 150 W PEP
- 5:1 VSWR CAPABILITY @ RATED CONDITIONS
- 3 dB OVERDRIVE CAPABILITY

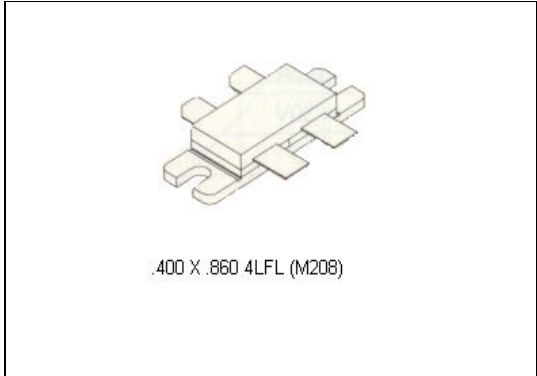

DESCRIPTION:

THE MS1578 IS A GOLD METALLIZED, EPITAXIAL SILICON, NPN PLANAR TRANSISTOR DESIGNED FOR HIGH LINEARITY CLASS AB OPERATION. DIFFUSED EMITTER BALLAST RESISTORS PROVIDE MAXIMUM RUGGEDNESS AND RELIABILITY FOR 900 MHz CELLULAR BASE STATION APPLICATIONS.

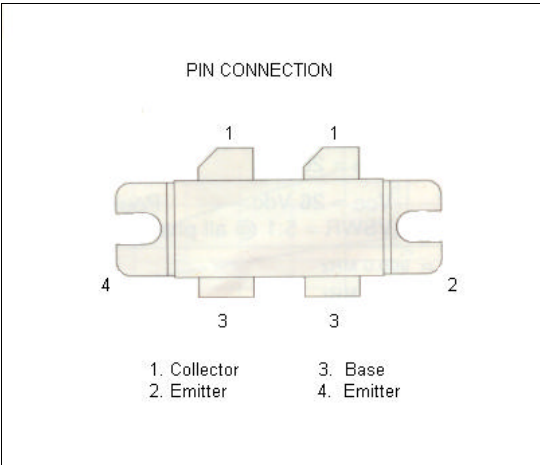

ABSOLUTE MAXIMUM RATINGS (Tcase = 25°C)

Symbol	Parameter	Value	Unit
V _{CEO}	Collector-Emitter Voltage	28	V
V _{CBO}	Collector-Base Voltage	65	V
V _{EBO}	Emitter-Base Voltage	3.5	V
I _C	Device Current	25	A
P _{DISS}	Power Dissipation	300	W
T _J	Junction Temperature	+200	°C
T _{STG}	Storage Temperature	- 65 to + 150	°C

Thermal Data

R _{TH(j-c)}	Junction-Case Thermal Resistance	0.60	°C/W
----------------------	----------------------------------	------	------

ELECTRICAL SPECIFICATIONS (T_{case} = 25°C)
STATIC

Symbol	Test Conditions		Value			Unit
			Min.	Typ.	Max.	
BV _{CBO}	I _C = 50 mA	V _{BE} = 0 V	60			
BV _{CER}	I _C = 100 mA	R _{BE} = 75 Ω	35	---	---	V
BV _{CEO}	I _C = 100 mA	I _B = 0 mA	28	---	---	V
BV _{EBO}	I _E = 10 mA	I _C = 0 mA	3.5	---	---	V
I _{CEO}	V _{CE} = 30 V	V _{BE} = 0 V	---	---	10	mA
h _{FE}	V _{CE} = 5 V	I _C = 6 A	25	---	120	

Tested per side

DYNAMIC

Symbol	Test Conditions		Value			Unit
			Min.	Typ.	Max.	
G _P *	V _{CC} = 26 Vdc	P _{OUT} = 150 W PEP I _{CQ} = 2 x 200 mA	8.5	9.0	---	dB
η _C *	V _{CC} = 26 Vdc	P _{OUT} = 150 W PEP I _{CQ} = 2 x 200 mA	30	---	---	%
IMD	V _{CC} = 26 Vdc	P _{OUT} = 150 W PEP I _{CQ} = 2 x 200 mA	---	-32	-28	dBc
LOAD* MISMATCH	V _{CC} = 26 Vdc	P _{OUT} = 150 W PEP I _{CQ} = 2 x 200 mA VSWR = 5:1 @ all phase angles				

*Note: f₁ = 900.0 MHz f₂ = 900.1 MHz

IMPEDANCE DATA

FREQ	Z _{IN} (Ω)	Z _{CL} (Ω)
800 MHz	4.25 + j12.25	5.75 - j4.25
860 MHz	4.75 + j10.25	5.00 - j3.00
900 MHz	7.75 + j10.25	4.25 - j2.90
960 MHz	8.50 + j 9.50	3.40 - j2.85
1000 MHz	8.50 + j13.25	2.75 - j3.15

P_{OUT} = 150W PEP V_{CE}=26V

TYPICAL PERFORMANCE

POWER OUTPUT vs POWER INPUT

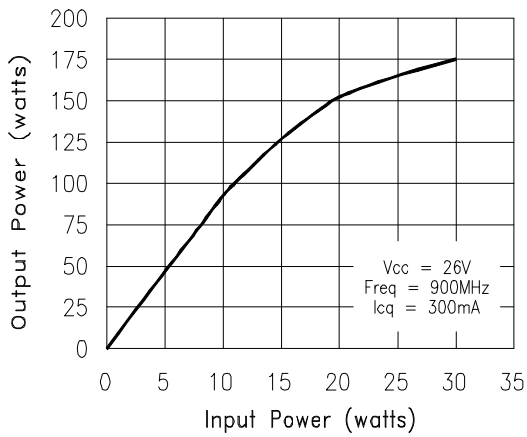

POWER GAIN vs POWER OUTPUT

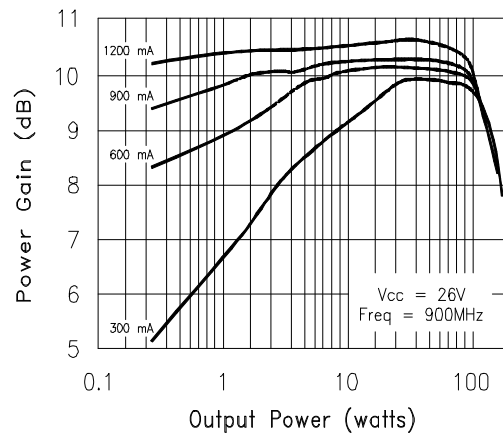

INTERMODULATION DISTORTION vs POWER OUTPUT

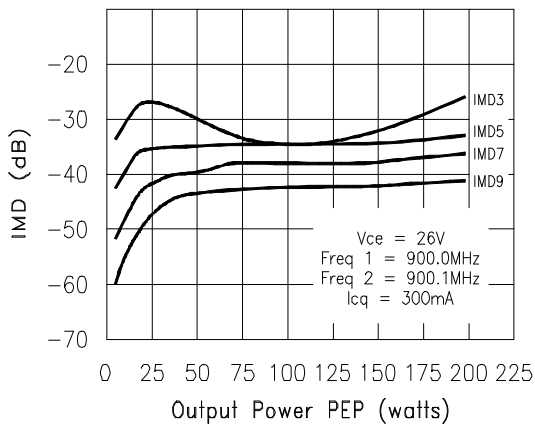

POWER OUTPUT vs SUPPLY VOLTAGE

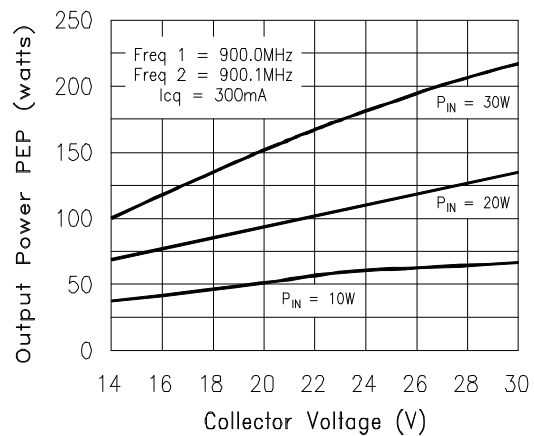

TEST CIRCUIT

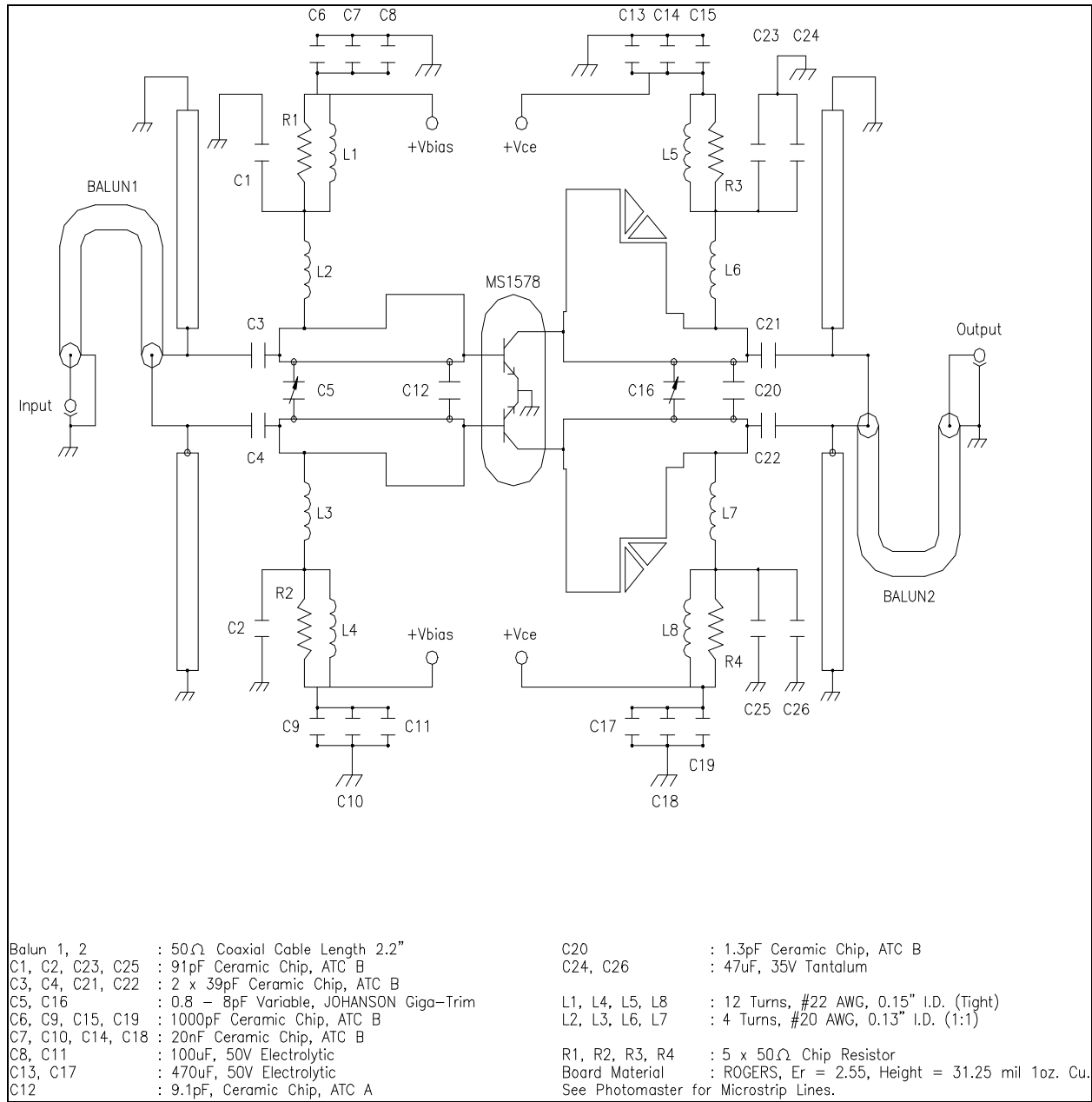

PACKAGE MECHANICAL DATA

