



High Speed Laser Diode Driver

The **HY6210 Laser Diode Driver** is a high speed, high current solid-state hybrid laser diode driver. It incorporates a patented technique of "backmatching" which allows remote drive of the laser diode through a 50Ω coaxial transmission line. This technique allows physical and thermal isolation of the laser diode and the driver. The laser diode can be driven through a transmission line without the need for a matched impedance termination. This removes a large source of heat that can be detrimental to high performance laser diode systems.

The HY6210 is used in applications that require digital, high speed, current modulation of the laser diode. The HY6210 input is ECL compatible and is terminated into 50Ω. The HY6210 uses a GaAsFET current switch that drives a laser diode with modulation currents of up to 200mA peak-to-peak. Two programmable current sources allow user selectability of the bias and modulation currents. The pre-bias current is selectable from zero to 40mA. The Modulation current is selectable from zero to 200mA. These selected currents modulate the laser beam at the input frequency. The HY6210 comes in a 22 pin dual in-line ceramic package. This package is not hermetically sealed and provides a cost effective alternative to the hermetic package of the HY6110 driver. An aluminum heat spreader is included as part of the package for heat sinking the device.



Features:

- ◆ Single ended ECL input (50Ω)
- ◆ Data rates up to 622Mbps
- ◆ Programmable bias current
- ◆ Adjustable modulation current
- ◆ Patented "backmatching" thermal management
- ◆ Backmatched output allows remote drive through 50Ω line

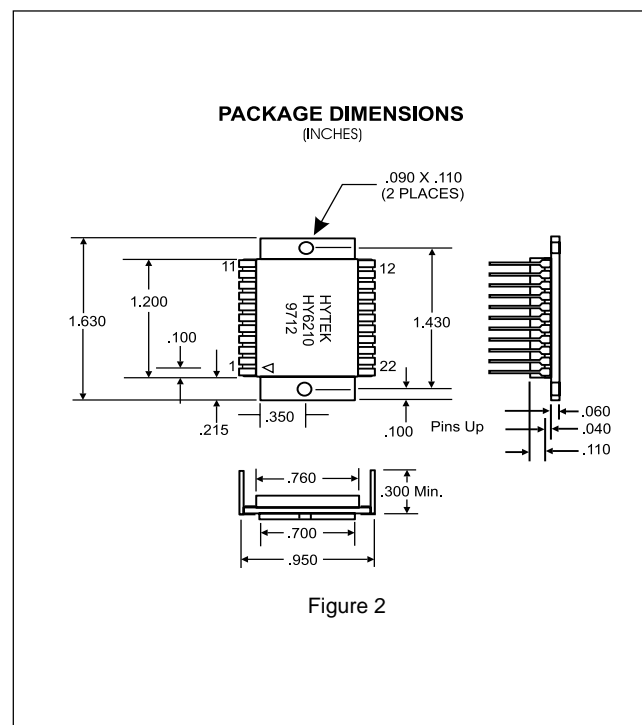
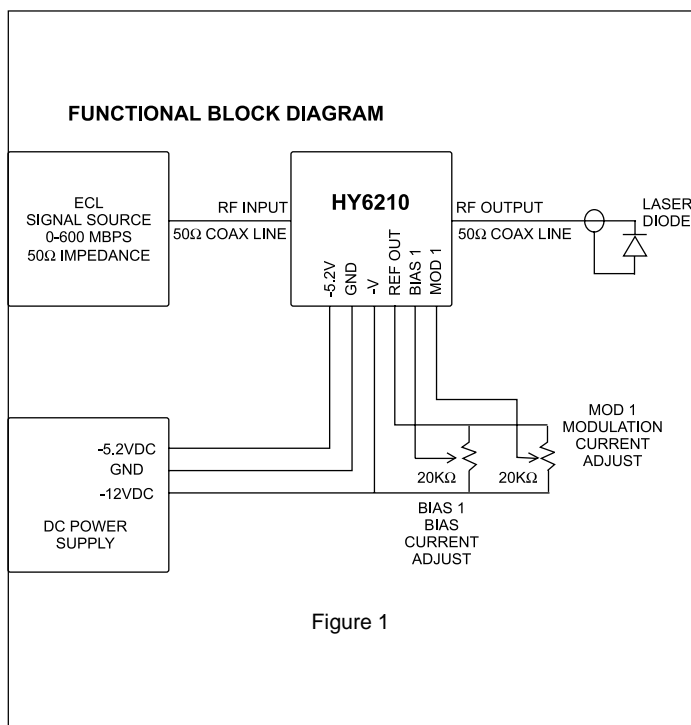

HY6210**Laser Diode Driver****Input Specifications**

Power Inputs	
-5.2V Supply	-4.9V to -5.5V @ 115mA max.
-12V Supply (-V)	-9V to -12V @ 220mA max.
RF IN	ECL logic levels, 0-622Mbps
BIAS I	0 to 40mA for input voltage -V to -V + 2V
MOD I	0 to 200mA for input voltage -V to -V + 0.5V

Output Specifications

RF OUT	Current output into 50Ω transmission line Low Current = BIAS I, High Current = MOD I
RF OUT Transmission Line Length	10 feet max.
REF OUT	-V +5V

Environmental Conditions

Operating Temperature	-55°C to 100°C (case)
Storage Temperature	-65°C to 150°C

Pin Designations

Description	HY6210
-5.2V input (-5.2V)	Pin 10
Ground (GND)	Pins 9, 13, 21
-V Input (-V)	Pin 8
Reference Voltage Output (REF OUT)	Pin 6
Bias I Adjust (BIAS I)	Pin 5
Modulation I Adjust (MOD I)	Pin 4
ECL Input Waveform (RF IN)	Pin 12
Laser Diode Current Driver (RF OUT)	Pin 22

Ordering Information

Model No. HY6210
Description: 200mA High Speed Laser Diode Driver; ceramic package
Application: ECL Digital Modulation of Laser Diode

Pin Descriptions

- > **-5.2V INPUT:** Power supply input for ECL buffer circuitry.
- > **GROUND:** Ground return for -5.2V ECL supply and -V.
- > **-V:** Power Supply input for Bias and Modulation currents as well as laser diode drive circuitry.
- > **REF OUT:** Precision reference output, +5V with respect to -V (if -V is -12V, REF OUT would be -7V).
- > **BIAS I:** Input used to set the Bias current for the laser diode. Maximum bias current occurs when the voltage at the BIAS I input is +2V with respect to the -V input. The voltage at the BIAS I input for a given bias current is determined by the equation: **$V(\text{BIAS I}) = -V + (\text{desired bias current}) \times 40\Omega$**
- > **MOD I:** Input used to set the Modulation current for the laser diode. This current is added to the Bias I current which always flows through the laser diode. Maximum modulation current occurs when the voltage at the MOD I input is +0.5V with respect to the -V input. The current set by the MOD I voltage is controlled by the ECL RF input. When the RF input is open or set to an ECL "low" input, only BIAS I current flows through the laser diode. The voltage at the MOD I input for a given modulation current is determined by the equation: **$V(\text{MOD I}) = -V + (\text{desired modulation current}) \times 2.5\Omega$**
- > **RF IN:** The input is terminated with an equivalent 50Ω into -2V required by the ECL logic family. This input accepts data rates up to 600Mbps.
- > **RF OUT:** The patented "backmatching" technique does not require a 50Ω termination at the laser diode end of the transmission line.