

Features

- a8237 MegaCore function implementing a programmable direct memory access (DMA) controller
- Optimized for FLEX® architecture
- Provides four independent channels
- Offers static read/write or handshaking modes
- Includes direct bit set/reset capability
- Uses approximately 1,201 FLEX logic elements (LEs)
- Functionally based on the Intel 8237A and Harris 82C37A devices, except as noted in “Variations & Clarifications” on page 24

General Description

The a8237 MegaCore function implements a programmable DMA controller, which controls memory-to-peripheral and memory-to-memory data transfers and provides block memory initialization capability. Four independently programmable channels are available in the a8237, and DMA requests can be made via hardware or software. [Figure 1](#) shows the symbol for the a8237.

Figure 1. a8237 Symbol

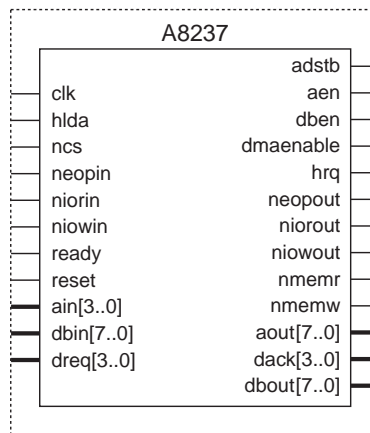

Table 1 describes the input and output ports of the a8237 MegaCore function.

Name	Type	Polarity	Description
clk	Input	–	Clock. Used to generate and synchronize a8237 operations.
hlda	Input	High	Hold acknowledge. This signal from the microprocessor indicates the release of the system bus to the a8237.
ncs	Input	Low	Chip select. When ncs is active, the a8237 is selected, and read and write transactions to internal registers are enabled.
neopin	Input	Low	End of process. Permits external termination of the current DMA service.
niorin	Input	Low	I/O read control. When niorin is low and the a8237 is selected, read transactions from internal registers are enabled.
niowin	Input	Low	I/O write control. When niowin is low and the a8237 is selected, data is asynchronously written into the a8237.
ready	Input	High	Ready. Extends the read and write pulses associated with slow memory or peripherals. When ready is low, wait states are inserted until ready returns high.
reset	Input	High	Reset. Clears the command, status, request, and temporary registers. Also clears the byte pointer, mode register counter, and the controller state machine. Sets the mask register so requests are ignored after initialization.
ain[3..0]	Input	–	Register address bus. Selects one of the internal a8237 registers. See Table 2 on page 9 .
dbin[7..0]	Input	–	Data bus input. The microprocessor writes data to internal registers via the dbin[7..0] bus.
dreq[3..0]	Input	–	DMA request bus. Programmable polarity. Asynchronous signals from peripherals requesting DMA service.
adstb	Output	High	Address strobe. Latches the MSB of the DMA address from about[7..0] into an external address latch.
aen	Output	High	Address enable. Enables an external address latch containing the most significant address byte of a DMA transfer.
dben	Output	High	Data bus enable. Active when data registers are read. Also active during DMA transfers, allowing the most significant bit (MSB) of the address to latch the output of temporary register data during memory-to-memory writes.
dmaenable	Output	High	DMA enable. Asserted during an active DMA cycle. Can create bidirectional signals from the niorin, niorout, niowin, and niowout signals, and the lower four bits of the address bus.
hrq	Output	High	Hold request. Requests control of the system bus.
neopout	Output	Low	End of process. Indicates normal termination of a DMA transfer.
niorout	Output	Low	I/O read output. Read strobe to I/O devices as DMA writes to memory.

Table 1. a8237 Ports (Part 2 of 2)

Name	Type	Polarity	Description
niowout	Output	Low	I/O write output. Write strobe to I/O devices as DMA reads from memory.
nmemr	Output	Low	Memory read. Read strobe to memory elements during DMA reads or memory-to-memory transfers.
nmemw	Output	Low	Memory write. Write strobe to memory elements during DMA writes or memory-to-memory transfers.
aout[7..0]	Output	–	Address output. During DMA service, aout[7..0] comprises the least significant byte of the DMA address.
dack[3..0]	Output	–	DMA acknowledge bus. Programmable polarity. Indicates a DMA cycle has been granted to the peripheral.
dbout[7..0]	Output	–	Data bus output. The microprocessor reads data from internal registers via the dbout[7..0] bus. Also used to output the most significant byte of the DMA address and temporary data held during memory-to-memory transfers.

Functional Description

Figure 2 shows a block diagram of the a8237 MegaCore function.

Figure 2. a8237 Block Diagram

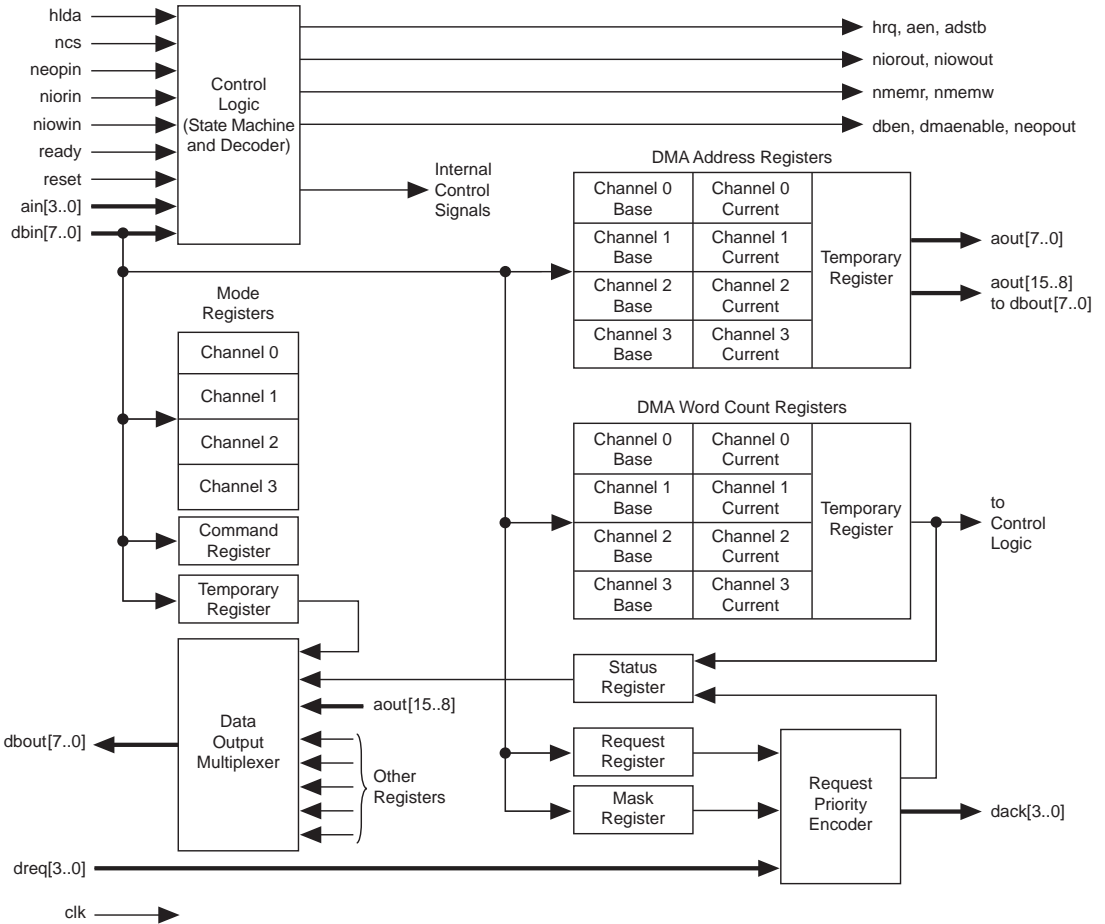

Programming

Several registers in the a8237 must be programmed before DMA cycles can be executed. However, to avoid unpredictable behavior, disable the DMA cycles during programming by setting bit 2 of the command register.

The microprocessor can program the a8237 when the `ncs` input and the `ain[3..0]` bus are asserted. When `niowin` and `ain[3..0]` are asserted, the microprocessor writes data to internal registers via the `dbin[7..0]` bus. When `niorin` and `ain[3..0]` are asserted, the microprocessor reads data from internal registers via the `dout[7..0]` bus. See “Host Processor Write Timing” and “Host Processor Read Timing” in Figure 3.

The byte pointer bit must be toggled to the correct value before operating on the DMA address register and word count register. The set byte pointer and clear mode register counter commands can change the contents of registers, effectively acting as write commands.

Register Address Map

Table 2 shows the register address map for the a8237.

ain3	ain2	ain1	ain0	Channel	Write (1), (2)	Read (1), (2)
0	0	0	0	0	Base and current DMA address register	Current DMA address register
0	0	0	1		Base and current DMA word count register	Current DMA word count register
0	0	1	0	1	Base and current DMA address register	Current DMA address register
0	0	1	1		Base and current DMA word count register	Current DMA word count register
0	1	0	0	2	Base and current DMA address register	Current DMA address register
0	1	0	1		Base and current DMA word count register	Current DMA word count register
0	1	1	0	3	Base and current DMA address register	Current DMA address register
0	1	1	1		Base and current DMA word count register	Current DMA word count register
1	0	0	0	X	Command register	Status register
1	0	0	1	X	Single request bit command	Request register
1	0	1	0	X	Single mask bit command	Command register
1	0	1	1	X	Mode register	Mode register
1	1	0	0	X	Clear byte pointer command	Set byte pointer command
1	1	0	1	X	Master clear command	Temporary register
1	1	1	0	X	Clear mask register command	Clear mode register counter
1	1	1	1	X	Mask register	Mask register

Notes:

- (1) If the byte pointer is set to 0, the byte pointer flag selects the least significant byte.
If the byte pointer is set to 1, the byte pointer flag selects the most significant byte.
The byte pointer flag is a single-bit internal register that selects either the least significant or most significant byte of the 16-bit registers in the a8237, allowing the microprocessor to write and read via the 8-bit data bus. See “Clear Byte Pointer Command” and “Set Byte Pointer Command” on page 17 for more information.
- (2) The X indicates “don’t care.”

Registers

The a8237 MegaCore function contains the following registers:

- Base address
- Current address
- Base word count
- Current word count
- Command
- Mode
- Request
- Mask
- Status
- Temporary

Base Address Register

Each of the four DMA channels has a base address register, which is a 16-bit register that contains the starting address for DMA transfers. If auto-initialization is enabled, the a8237 loads the base address value into the current address register at the conclusion of a DMA cycle. The microprocessor writes to the base address register in two parts via $\text{dbin}[7..0]$, and simultaneously loads the current address register. The byte pointer flag chooses either the least significant or most significant byte. The microprocessor cannot read the base address register.

Current Address Register

Each of the four DMA channels has a current address register, which is a 16-bit register containing the working address value for DMA transfers. The microprocessor loads the current address register simultaneously with the base address register via $\text{dbin}[7..0]$. If auto-initialization is enabled, the a8237 reloads the base address value at the conclusion of a DMA cycle. The microprocessor reads or writes to the current address register in two parts via the 8-bit data bus. The byte pointer flag chooses the least significant or most significant byte. After each DMA transfer, the current address value is updated with the incremented or decremented value from the temporary address register (except for channel 0 in memory-to-memory mode when the address can be held constant).

Base Word Count Register

Each of the four DMA channels has a base word count register, which is a 16-bit register containing the beginning word count for DMA transfers. If auto-initialization is enabled, the a8237 loads the base word count value into the current word count register at the conclusion of a DMA cycle. The microprocessor writes to the base word count register in two parts via $\text{dbin}[7..0]$, and simultaneously loads the current word count register. The byte pointer flag chooses the least significant or most significant byte. The microprocessor cannot read the base word count register.

Current Word Count Register

Each of the four DMA channels has a current word count register, which is a 16-bit register containing the working word count value for DMA transfers. The microprocessor loads the current word count value simultaneously with the base word count register via $\text{dbin}[7..0]$. If auto-initialization is enabled, the a8237 reloads the base word count value at the conclusion of a DMA cycle. The microprocessor reads or writes to the current word count register in two parts via the 8-bit data bus. The byte pointer flag chooses the least significant or most significant byte. After each DMA transfer, the current word count value is updated with the decremented value from the temporary word count register. A terminal count flag is generated when the count rolls over from zero to hexadecimal FFFF. The number of DMA transfers is one more than the value written to the current word count register. For example, if a 16-word transfer is desired, the word count should be hexadecimal 000F.

Command Register

The command register configures the operation of the a8237, such as dreq and dack polarity, request priority, function enables/disables, and transfer timing. The microprocessor reads from or writes to the command register via the 8-bit data bus. The reset input or a master clear command clears the command register. See [Table 3](#).

Bit	Description
0	0 = Memory-to-memory disable 1 = Memory-to-memory enable
1	0 = Channel 0 address hold disable 1 = Channel 0 address hold enable X if bit 0 = 0, <i>Note (1)</i>
2	0 = Controller enable 1 = Controller disable
3	0 = Normal timing 1 = Compressed timing X if bit 0 = 1, <i>Note (1)</i>
4	0 = Fixed priority 1 = Rotating priority
5	0 = Late write 1 = Extended write X if compressed timing, <i>Note (1)</i>
6	0 = <code>dreq</code> active high 1 = <code>dreq</code> active low
7	0 = <code>dack</code> active low 1 = <code>dack</code> active high

Note:

(1) The X indicates “don’t care.”

Mode Register

The 6-bit mode registers contain the configuration for each of the four DMA channels. When writing from `dbin[7..0]`, the first two bits of the mode register format selects the DMA channel mode register. Before reading each of the mode registers, the clear mode register counter command must be executed. The next read from the mode register address returns the value from the channel 0 mode register. Subsequent mode register reads step through the other mode registers in order. See [Table 4](#).

Bit	Description
1..0	00 = Channel 0 select 01 = Channel 1 select 10 = Channel 2 select 11 = Channel 3 select 11 during Read
3..2	00 = Verify transfer 01 = Write transfer 10 = Read transfer 11 = Illegal
4	0 = Auto-initialization disable 1 = Auto-initialization enable
5	0 = Address increment 1 = Address decrement
7..6	00 = Demand mode select 01 = Single mode select 10 = Block mode select 11 = Unused (Cascade mode is not supported.)

Request Register

The 4-bit request register allows software DMA requests. Hardware requests (from `dreq` inputs) are masked by the mask register values; software requests generated from the request register are unmaskable. The request register request bits can only be programmed by the single request bit command. The `reset` input or a master clear command clears the request register. See [Table 5](#).

Bit	Description
0	1 = Channel 0 request
1	1 = Channel 1 request
2	1 = Channel 2 request
3	1 = Channel 3 request
7..4	1111

Mask Register

The 4-bit mask register can be set to disable an incoming DMA request, and contains the mask flags for the `dreq` inputs of each channel. The microprocessor can read or write to the mask register via the 8-bit data bus. Also, the microprocessor can write individual bits of the mask register with the single mask bit command. The `reset` input or a master clear command sets all bits in the mask register. See [Table 6](#).

Bit	Description
0	0 = Channel 0 unmasked 1 = Channel 0 masked
1	0 = Channel 1 unmasked 1 = Channel 1 masked
2	0 = Channel 2 unmasked 1 = Channel 2 masked
3	0 = Channel 3 unmasked 1 = Channel 3 masked
7..4	XXXX during write, Note (1) 1111 during read

Note:

(1) The X indicates “don’t care.”

Status Register

The 8-bit status register contains the status flags of the four DMA channels. Each DMA channel has a terminal count flag and a request flag. The terminal count flag indicates that a DMA cycle is complete or has been terminated by the `neopin` signal since the last read of the status register. The request flag indicates the `dreq` input of a channel is asserted regardless of the state of the associated mask bit. The status register is reset by the `reset` input or the master clear command. The terminal count flags are reset on each read of the status register. See [Table 7](#).

Table 7. Status Register Format

Bit	Description
0	Channel 0 terminal count
1	Channel 1 terminal count
2	Channel 2 terminal count
3	Channel 3 terminal count
4	Channel 0 request
5	Channel 1 request
6	Channel 2 request
7	Channel 3 request

Temporary Register

The 8-bit temporary register holds the data value for memory-to-memory DMA transfers. Reading this register from the microprocessor via `dbout[7..0]` yields the last data value transferred during the most recent memory-to-memory DMA cycle. The temporary register cannot be written to directly by the microprocessor via `dbin[7..0]`, but can be cleared by the `reset` input or a master clear command.

Commands

The a8237 MegaCore function can perform the following commands:

- Single request bit command
- Single mask bit command
- Clear byte pointer command
- Set byte pointer command
- Master clear command
- Clear mask register command
- Clear mode register counter command

These commands are issued by performing either a read or write operation with a specific address on `ain[3..0]`. [Table 2 on page 9](#) shows how to issue these commands.

Single Request Bit Command

The single request bit command alters a single bit of the 4-bit request register. See [Table 8](#).

Table 8. Single Request Bit Command Format	
Bit	Description
1..0	00 = Channel 0 select 01 = Channel 1 select 10 = Channel 2 select 11 = Channel 3 select
2	0 = Reset request bit 1 = Set request bit
7..3	XXXXX during write, Note (1)

Note:

(1) The X indicates “don’t care.”

Single Mask Bit Command

The single mask bit command alters a single bit of the 4-bit mask register. See [Table 9](#).

Table 9. Single Mask Bit Command Format	
Bit	Description
1..0	00 = Channel 0 mask bit select 01 = Channel 1 mask bit select 10 = Channel 2 mask bit select 11 = Channel 3 mask bit select
2	0 = Reset mask bit 1 = Set mask bit
7..3	XXXXX during write, Note (1)

Note:

(1) The X indicates “don’t care.”

Clear Byte Pointer Command

The byte pointer is a single-bit internal register that selects either the least significant or most significant byte of the 16-bit registers in the a8237. The byte pointer allows microprocessor write and read operations via the 8-bit data bus. The clear byte pointer command is a write command that resets the byte pointer, allowing subsequent access to the least significant byte of any 16-bit register. The data bus value for the clear byte pointer command is ignored. The reset input and the master clear command resets the byte pointer.

Set Byte Pointer Command

The set byte pointer command is a read command that sets the byte pointer, allowing subsequent access to the most significant byte of any 16-bit register. The data bus value for the set byte pointer command is unknown. The byte pointer is reset by the reset input and the master clear command.

Master Clear Command

The master clear command performs the same function as the reset input. This command resets the command, status, request, temporary and byte pointer registers, mode register counter, state machine, and also sets the mask register.

Clear Mask Register Command

The clear mask register command is a write command that resets the 4-bit mask register, enabling DMA requests from the `dreq` inputs. The data bus value for the clear mask register command is ignored.

Clear Mode Register Counter Command

The clear mode register counter command is a read command that resets the 2-bit mode register counter. This counter is incremented after each subsequent read of the mode register, allowing the user to cycle through all four mode registers. The data bus value for the clear mode register counter command is unknown.

Operation

This section describes the following a8237 MegaCore function operations:

- State machine
- Transfer modes
- Other operations

State Machine

The a8237 state machine synchronously controls various functions and can execute two types of DMA transfers. The memory to/from I/O transfer executes a simultaneous read and write operation, which requires a total of four states. The memory-to-memory transfer must perform the read and write operation separately, which requires a total of eight states (i.e., four states to read a memory location and store the data value in the temporary register, and another four to write the data value to a new memory location). The state machine loops through these states until the word count decrements to zero or until the transfer is externally aborted.

Upon reset, the state machine enters an SI state. In the SI state, the internal registers can be programmed to the appropriate configuration. After programming, the a8237 continuously samples any unmasked DMA request (\overline{dreq}) inputs. If a valid \overline{dreq} is detected, the state machine transitions into the acquire bus state. See [Figure 3 on page 22](#).

In the S0 state, the hrq output is asserted, and the state machine waits for the microprocessor to assert $hlda$. When the $hlda$ input is asserted, the a8237 controls the microprocessor via the 8-bit data bus, allowing DMA transfers to begin.

- The S1 state is the first state of a DMA transfer, where the aen and $adstb$ signals are asserted. The most significant byte of the address appears on the $\overline{dout}[7..0]$ bus, and the least significant byte of the address appears on the $\overline{aout}[7..0]$ bus.
- The S2 state is the second state, where $adstb$ is deasserted, latching the most significant byte of the address from $\overline{dout}[7..0]$ into the external latch.
- The S3 state is the third state, where $\overline{niorout}$ or \overline{nmemr} is asserted, depending on the direction of the DMA transfer.
- The S4 state is the fourth state, where $\overline{niowout}$ or \overline{nmemw} is asserted. If the end of the DMA cycle has not been reached, the state machine loops to the S2 state for the next transfer. If the most significant byte of the address does not change in subsequent cycles of the DMA transfer, then the S4 state transitions directly to the S2 state (i.e., the S1 state is skipped), which effectively suppresses $adstb$ generation and speeds up block transfers.

For memory-to-memory transfers, eight states are executed: four states to read a memory location and store the data value in the temporary register, and another four to write the data value to a new memory location. The equivalent of a S1 state is always executed for both memory accesses.

To compensate for slower memory or peripherals, additional wait states can be inserted before the write state by holding `ready` low. Returning `ready` to high halts the insertion of wait states, allowing normal operation to continue beginning with the next cycle.

Transfer Modes

The a8237 MegaCore function has three transfer modes: single transfer, block transfer, and demand transfer modes.

- In single transfer mode, only one DMA transfer is executed, and the state machine enters the S1 state to allow prioritized access by other DMA channels.
- In block transfer mode, the DMA transfers continue uninterrupted until the transfer is completed or `neopin` is asserted.
- In demand transfer mode, the DMA transfers can be interrupted by deasserting the `dreq` input. When `dreq` is reasserted, the DMA transfers restart from the point at which they were stopped.

Other Operations

In addition to the state machine and transfer modes, the a8237 also provides the following operations for controlling DMA transfers:

- Auto-initialization
- Verify transfer
- Memory-to-memory transfer
- Priority encoding
- Compressed timing
- Extended timing

Auto-initialization

Auto-initialization allows each DMA channel to reinitialize after the completion of a DMA cycle without microprocessor intervention. This feature is enabled by setting bit 4 of each channel's mode register. The current address and current word count registers are loaded with the values contained in the base address and base word count registers following the normal or aborted (by the `neopin` signal) conclusion of a DMA cycle.

Verify Transfer

The verify transfer type operates as a normal DMA read or write operation, except that the I/O and memory control signals remain deasserted. (The verify transfer type originated as a means to refresh DRAM in early personal computers.)

Memory-to-Memory Transfer

The memory-to-memory DMA transfers are enabled via bit 0 of the command register, and must be performed using channels 0 and 1. The transfer is initiated by a software or hardware request on channel 0. At the conclusion of the DMA cycle, the terminal count bit for channel 1 is set in the status register, while the counterpart for channel 0 remains unchanged. Also, channel 0 can be configured to hold the address constant, allowing memory fills with a single data value.

Priority Encoding

The DMA requests are priority encoded to arbitrate between simultaneous requests or multiple pending requests. Two modes of priority encoding are available via bit 4 of the command register:

- In fixed priority mode, the highest priority pending request is selected, with channel 0 as the highest priority and channel 3 as the lowest priority.
- In rotating priority mode, the last channel to be serviced becomes the lowest priority when selecting the next channel, with the other channels rotating accordingly.

Compressed Timing

Compressed timing operation speeds the DMA transfer state machine loop by skipping the S3 state, thereby forcing the read and write pulses to be of equal duration (i.e., one clock cycle). This operation is enabled by setting bit 3 of the command register. Compressed timing operation cannot be used for memory-to-memory transfers.

Extended Timing

Extended timing operation asserts the write pulse during the S3 state, thereby forcing the read and write pulses to be of equal duration (i.e., two clock cycles). This operation is enabled by setting bit 5 of the command register. Extended timing operation cannot be used for memory-to-memory transfers.

Timing Waveforms

Figure 3 shows the timing waveforms for the a8237 MegaCore function.

Figure 3. a8237 Timing Waveforms (Part 1 of 3)

Two-Word DMA Cycle

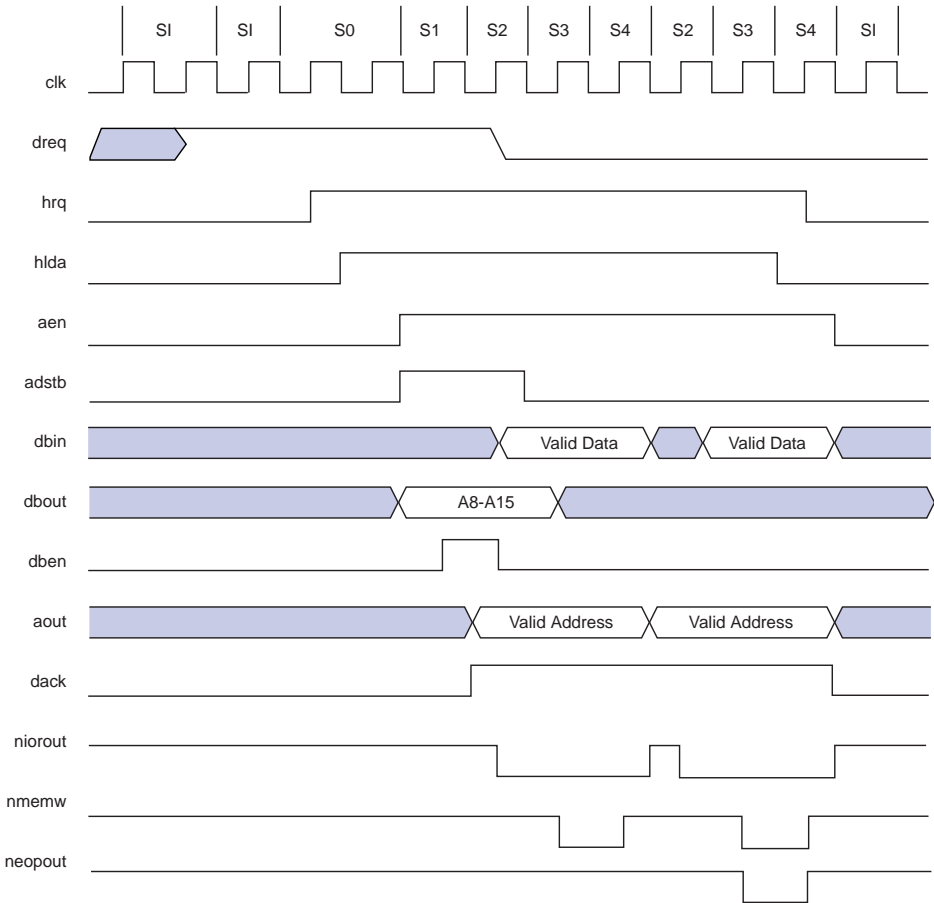

Figure 3. a8237 Timing Waveforms (Part 2 of 3)

Memory-to-Memory DMA Transfer

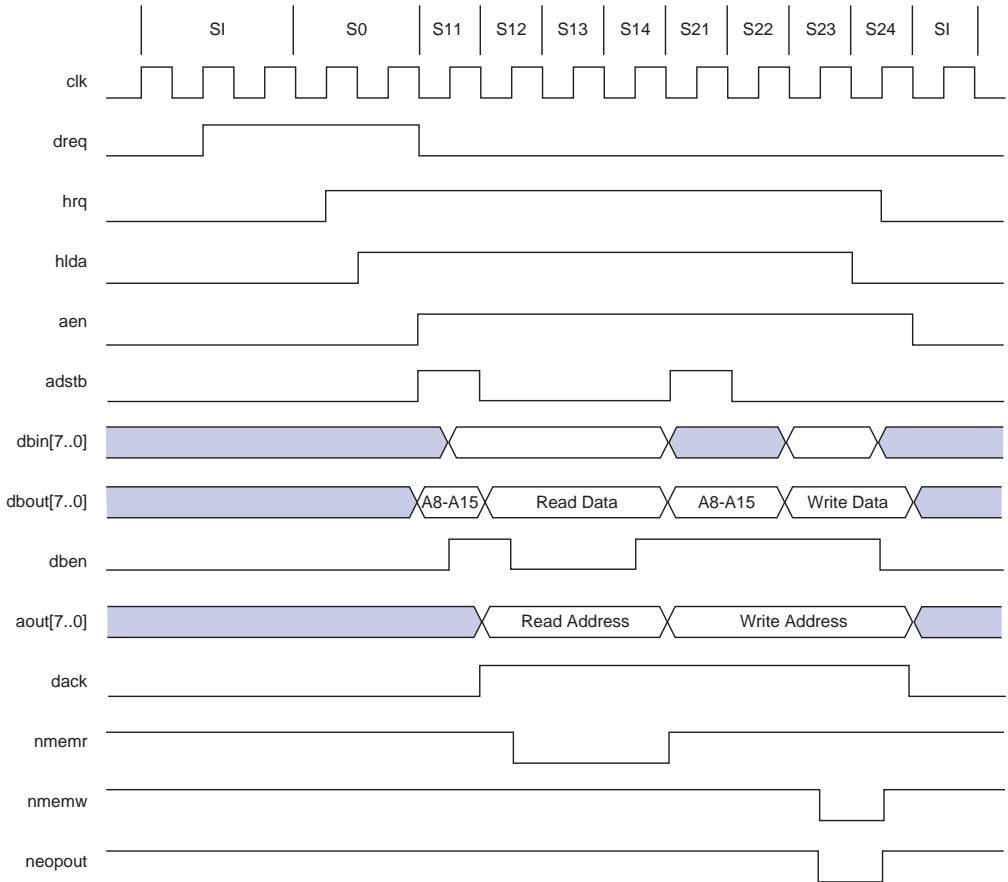
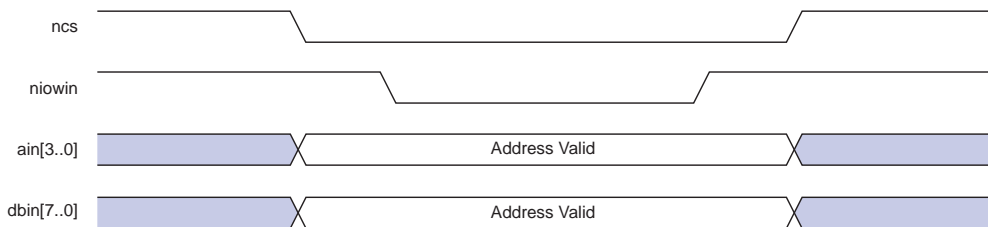
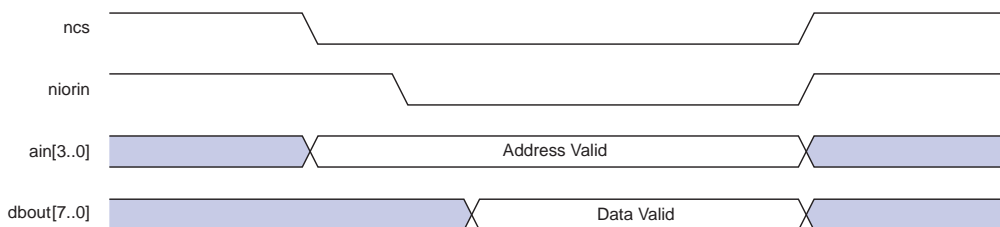

Figure 3. a8237 Timing Waveforms (Part 3 of 3)**Host Processor Write Timing****Host Processor Read Timing**

Variations & Clarifications

The following list provides clarifications on Altera's implementation of the a8237 and the functionality of the Intel 8237A and Harris 82C27A devices. Altera believes that the a8237 provides consistent functionality to that of the Intel and Harris devices. These interpretations have been implemented in the Altera a8237 MegaCore function and are believed to be consistent with the implementation of the Intel and Harris devices.

- The `neopin` is asserted for at least one clock cycle terminates a DMA cycle at the end of the current transfer. The `neopin` output is asserted at the normal conclusion of a DMA cycle, but not asserted when the DMA cycle is aborted by a `neopin`.
- The `reset` input or the master clear command clears the temporary data register used in memory-to-memory transfers, including the temporary address and word count registers.
- The a8237 does not implement wait-state support for memory-to-memory transfers.

The following list provides more information on the differences between Altera's implementation of the a8237 and the functionality of the Intel 8237A and Harris 82C27A devices.

- In the a8237 function, tri-state outputs and bidirectional ports are split into separate inputs, outputs, and enables as necessary.

- The a8237 does not support the cascade mode because it would not be an efficient use of device resources. To implement this capability, the designer should use a hand-coded module or a stripped down a8237 function.
- On the rising edge of `CLK`, the Harris 82C37A deasserts `nMEMR` on states 4 and 14, and deasserts `nIOROUT` on state 4. However, this approach is not reliable from a timing perspective for a CPLD. The Altera a8237 deasserts `nMEMR` on the falling edge of `CLK` at the end of states 4 and 14 and `nIOROUT` at the end of state 4. This action effectively extends the assertion of these signals by a 1/2 clock cycle.

Revision History

The information contained in the *a8237 Programmable DMA Controller Data Sheet* version 1.01 supersedes information published in previous versions. Version 1.01 includes the following changes:

- The “State Machine” on page 18 was updated.
- The waveforms in Figures 2 and 3 were updated.
- The “Variations & Clarifications” on page 24 was updated.
- Minor style and text changes were made throughout the document.

Copyright © 1995, 1996, 1997, 1998, 1999 Altera Corporation, 101 Innovation Drive,
San Jose, CA 95134, USA, all rights reserved.

By accessing this information, you agree to be bound by the terms of Altera's
Legal Notice.