

PLEASE CHECK WWW.MOLEX.COM FOR LATEST PART INFORMATION

Part Number: [0016020078](#)
Status: **Active**
Overview: [cgrid_sl_products](#)
Description: SL™ Crimp Terminal, Series 70021, Male, with 0.76μm (30μ") Selective Gold (Au) Plated Contact, 24-30 AWG, Reel

Documents:

[Drawing \(PDF\)](#) [RoHS Certificate of Compliance \(PDF\)](#)
[Product Specification PS-70021 \(PDF\)](#)

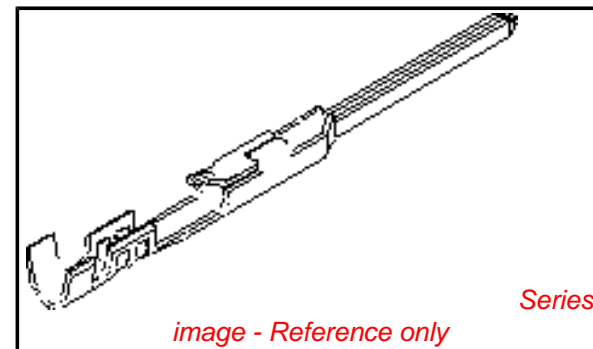

General

Product Family	Crimp Terminals
Series	70021
Crimp Quality Equipment	Yes
Overview	cgrid_sl_products
Product Name	SL™

Physical

Gender	Male
Material - Metal	Phosphor Bronze
Material - Plating Mating	Gold
Material - Plating Termination	Tin
Packaging Type	Reel
Plating min: Mating (μin)	30
Plating min: Mating (μm)	0.75
Plating min: Termination (μin)	75
Plating min: Termination (μm)	1.875
Termination Interface: Style	Crimp or Compression
Wire Insulation Diameter	1.52mm (.060") max.
Wire Size AWG	24, 26, 28, 30
Wire Size mm ²	N/A

Material Info

Old Part Number 70021-0008

Reference - Drawing Numbers

Packaging Specification	PK-70873-1300
Product Specification	PS-70021
Sales Drawing	SD-70021-0008

EU RoHS	China RoHS
ELV and RoHS Compliant	
REACH SVHC Contains SVHC: No	
Halogen-Free Status	
Halogen-Free	

Need more information on product environmental compliance?

Email productcompliance@molex.com
For a multiple part number RoHS Certificate of Compliance, [click here](#)

Please visit the [Contact Us](#) section for any non-product compliance questions.

Search Parts in this Series
[70021Series](#)

Use With
[70066 Housing](#), [70107 Housing](#)

Application Tooling | [FAQ](#)
Tooling specifications and manuals are found by selecting the products below. Crimp Height Specifications are then contained in the Application Tooling Specification document.

Global Description	Product #
FineAdjust™ Applicator for SL™ Crimp Terminal, Male, 22 AWG, 41 Strands/44 AWG Wire	0639014500
Hand Crimp Tool, UL Approved T2 Terminator Tooling Die	0639103400

FineAdjust™	<u>0639003400</u>
Applicator for SL™ Male Crimp Terminal, 24-30 AWG	
Insertion Tool	<u>0011020022</u>
Extraction Tool	<u>0011030036</u>

Japan

Description	Product #
Applicator for M211A Bench Press, 22-30 AWG, for 70021 Crimp Terminal	<u>0570173000</u>
Hand Insertion Tool	<u>0570336000</u>

This document was generated on 05/18/2010

PLEASE CHECK WWW.MOLEX.COM FOR LATEST PART INFORMATION

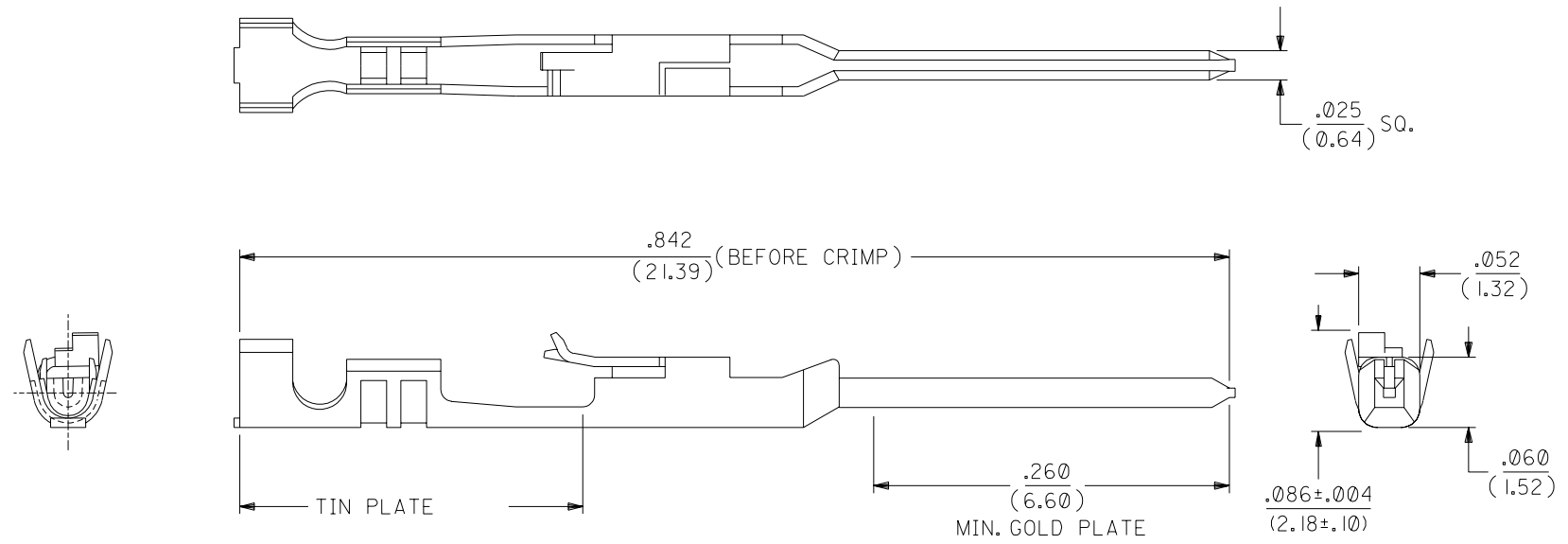

NOTES:

1. TERMINAL FOR USE WITH HOUSING PART NO. 70066-**** & 70107-****.
2. MATERIAL: .008/(0.20) THK. PHOSPHOR BRONZE.
3. TERMINAL TO BE USED WITH 24-30 AWG STRANDED WIRE WITH .060 DIA. MAX. INSULATION.
4. REFER TO MOLEX OPERATIONAL AND SERVICE MANUAL FOR DETAILS.
5. REFER TO PRODUCT SPECIFICATION NO. PS-70021.
6. PARTS SUPPLIED IN REEL FORM.

PLATING:

30 GOLD - .000030 MIN. GOLD PLATE IN SELECT AREA,
 .000075 MIN. TIN PLATE IN SELECT AREA,
 OVER .000050 MIN. NICKEL PLATE OVERALL.

*THE PRIMARY SHIPPING CARTON WILL BE LABELED "COMPLIANT TO
 RoHS DIRECTIVE 2002/95/EC AND ELV ANNEX II OF DIRECTIVE 2000/53/EC".
 CARTONS WITHOUT THIS LABEL MAY CONTAIN PRODUCT WITH LEAD.

G	LEAD FREE UCP2004-1769 RWHITE 04/03/12
FI	REVISED ECR #U80270 MCGRATH 97/07/31
F	REVISED PLTG. SPEC. PER ECR # U31149 08/17/93 REED
E	REVISED PER ECR # U82220 11-07-88 MJM/MGB
D	REDRAWN ON CAD PER E.C.M. #9509 11/10/86 WJF/MJM

MFG.	SH.	REV.	LTR.	REVISIONS
------	-----	------	------	-----------

DIMENSIONS SHOWN (METRIC) INCH		▽ = 0 ▼ = 0		REVISE ONLY ON CAD SYSTEM	
UNLESS OTHERWISE SPECIFIED TOLERANCES: ANGULAR ± 1/2°					
		INCH		METRIC	
3 PLACE	± .010	---		---	
2 PLACE	± .015	± 0.25		---	
1 PLACE	---	± 0.35		---	
DRAFT WHERE APPLICABLE MUST REMAIN WITHIN DIMENSIONS					
DRWG. BY: WJF		CHK'D. BY: MJM		FILE NAME: S70021X7 DGN	
APP'D. BY: WAZ		SCALE: 10:1		THIS DRAWING CONTAINS INFORMATION THAT IS PROPRIETARY TO MOLEX INC. AND SHOULD NOT BE USED WITHOUT WRITTEN PERMISSION.	
MOLEX INCORPORATED LISLE, ILL. 60532 U.S.A.		PART NO. 16-02-0078		SHEET NO. 1 DATE 10/30/86	
TITLE: TERMINAL, MALE CRIMP		DRWG. NO. SD-70021-0008		DIV. DA SIZE B	