

General Description

The device LDS297P is an adjustable accurate low-power solid-state thermostat. The temperature trip point can be set with one external resistor from 50°C to 150°C with an accuracy of 3 degrees. The thermal hysteresis is internally programmed to guarantee stability at the transition point.

The device LDS297P is used to protect systems from overheating above the normal rating of components like capacitors, batteries, or any other temperature sensitive component. The device LDS297P is also used in battery management systems to stop the battery charge when the battery temperature is outside of the safe temperature range.

The output OT is an open drain output that can sink up to 50mA when the threshold temperature is reached. The minimum voltage of operation is 2.2 V.

Applications

- Battery Chargers
- Electronic System protection
- Fan Control
- Microprocessor Thermal Management
- HVAC Systems

Features

- +/-3 degrees Celsius accuracy
- Adjustable temperature trip point
- Open-drain output capable of 50mA
- Internally programmed thermal hysteresis
- Low input voltage and current
- Excellent power supply noise rejection
- Offered in very small SOT23-5 package.
- RoHS Compliant

Block Diagram

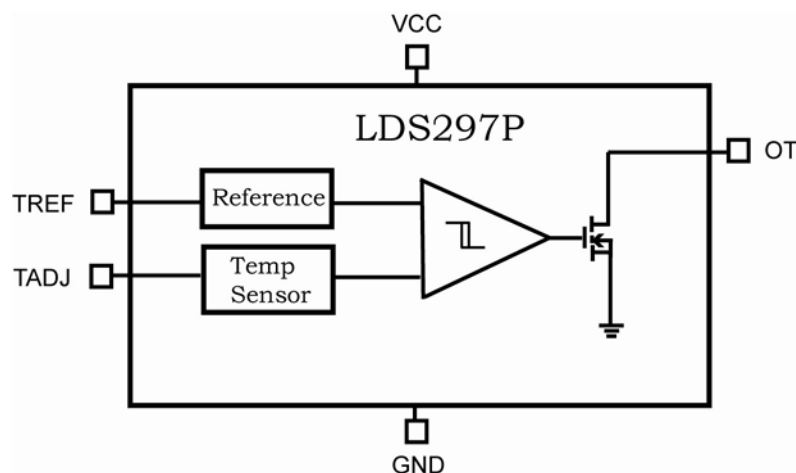

Pin Configuration

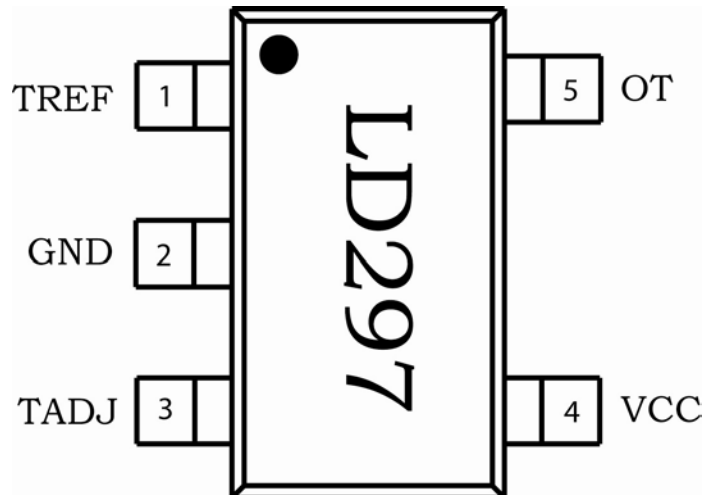

Pin Descriptions

Pin num	Pin Name	Function
1	TREF	Reference connects to temperature adjust resistor
2	GND	Ground
3	TADJ	Adjust pin, connects to temperature adjust resistor
4	VCC	V supply. Must be greater than 2.2V for normal operation.
5	OT	Normally Open Drain, V_{DSS} when thermal threshold is reached.

Absolute Maximum Ratings

Stress greater than those listed under “Absolute Maximum Ratings” may cause permanent damage to the device. These are stress ratings only, and functional operation of the device at these or any conditions beyond those indicated under recommended Operating Conditions is not implied. Exposure to “Absolute Maximum Rating” for extended periods may affect device reliability. Use of standard ESD handling precautions is required.

Parameter	Value	Units
VCC Voltage	18	V
VOT Voltage	18	V
IOT Current	80	mA
ITREF Current	10	mA
ITADJ Current	10	mA
Operating Junction Temperature	155	°C
Lead Temperature (soldering 10 seconds)	260	°C
Storage Temperature Range	-65 to +150	°C

Electrical Specifications

Electrical characteristics are guaranteed over the full temperature range $-55^{\circ}\text{C} < T_j < 150^{\circ}\text{C}$ unless otherwise stated. Ambient temperature must be de-rated based upon power dissipation and package thermal characteristics. Unless otherwise specified: VCC = 5V, TREF and TADJ = no connect, $T_j = 25^{\circ}\text{C}$

Symbol	Parameter	Conditions	Min	Typ	Max	Units
IVCC	Input Current			80	120	μA
IVCC	Input Current	$T_j > \text{trip temperature}$		1.5	2.0	mA
VCC	Input Voltage		2.2		16	V
VOT	Output V_{DSS}	IC = 10mA $T_j > \text{trip temperature}$		0.15	0.25	V
IOT	Output leakage current	VCC = 16V		0.2	0.4	μA
OTT	Over temp Threshold	Unadjusted	117	120	123	°C
TOT	Over temp accuracy	Adjusted	-3		3	°C
HOT	Hysteresis			5		°C

Notes:

Typical Application

The device LDS297P is very simple to use. It is recommended to place the LDS297P in close proximity of the device whose temperature is to be sensed. The device LDS297P has an open drain output which is capable of sinking up to 50mA when the sensed temperature exceeds the trip point. The temperature trip point can be set by the addition of an external resistor RSET between the TREF and the TADJ pins as depicted in FIG.1 below.

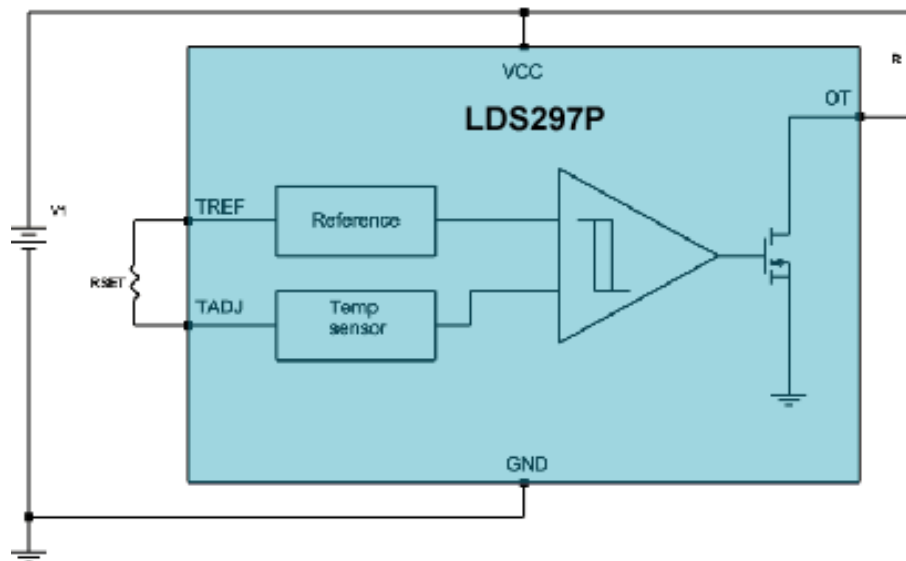
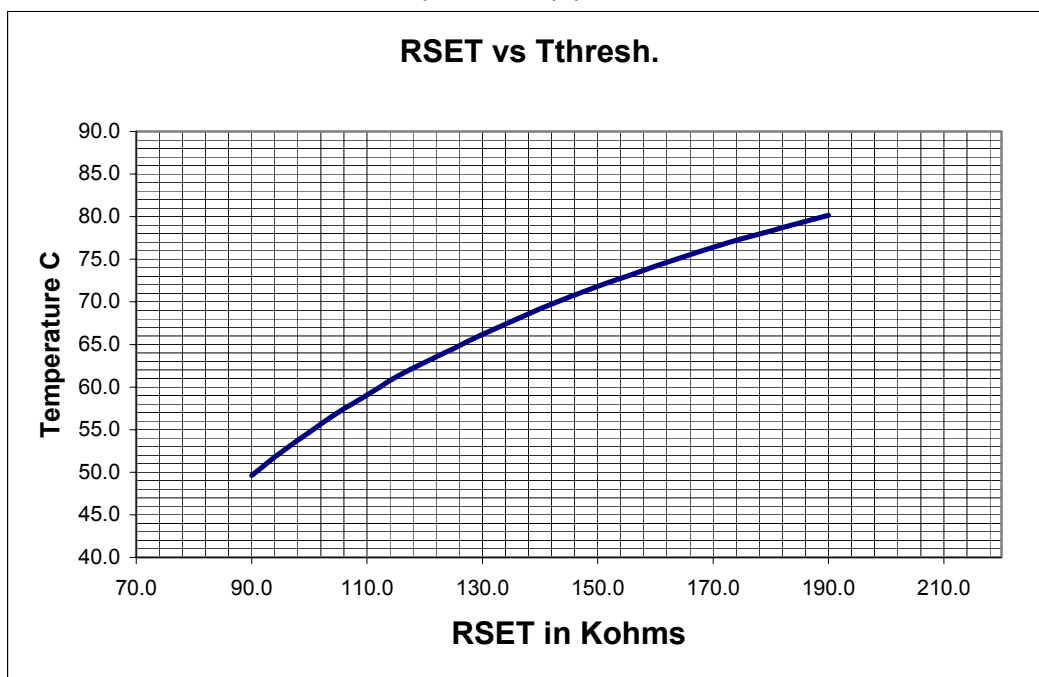

FIG.1

It is assumed that the temperature coefficient of the external resistor be close to zero as it commonly is. Higher accuracy resistors guarantee higher accuracy temperature trip point. The resistor RSET value should be selected according to the table below to determine the desired temperature trip point. The table in particular shows the desired resistor value for the temperature range between 50°C and 80°C. If no external resistor is selected the temperature trip point will be 120°C.



Package Dimensions

SOT23-3, SOT23-4, SOT23-5, SOT23-6

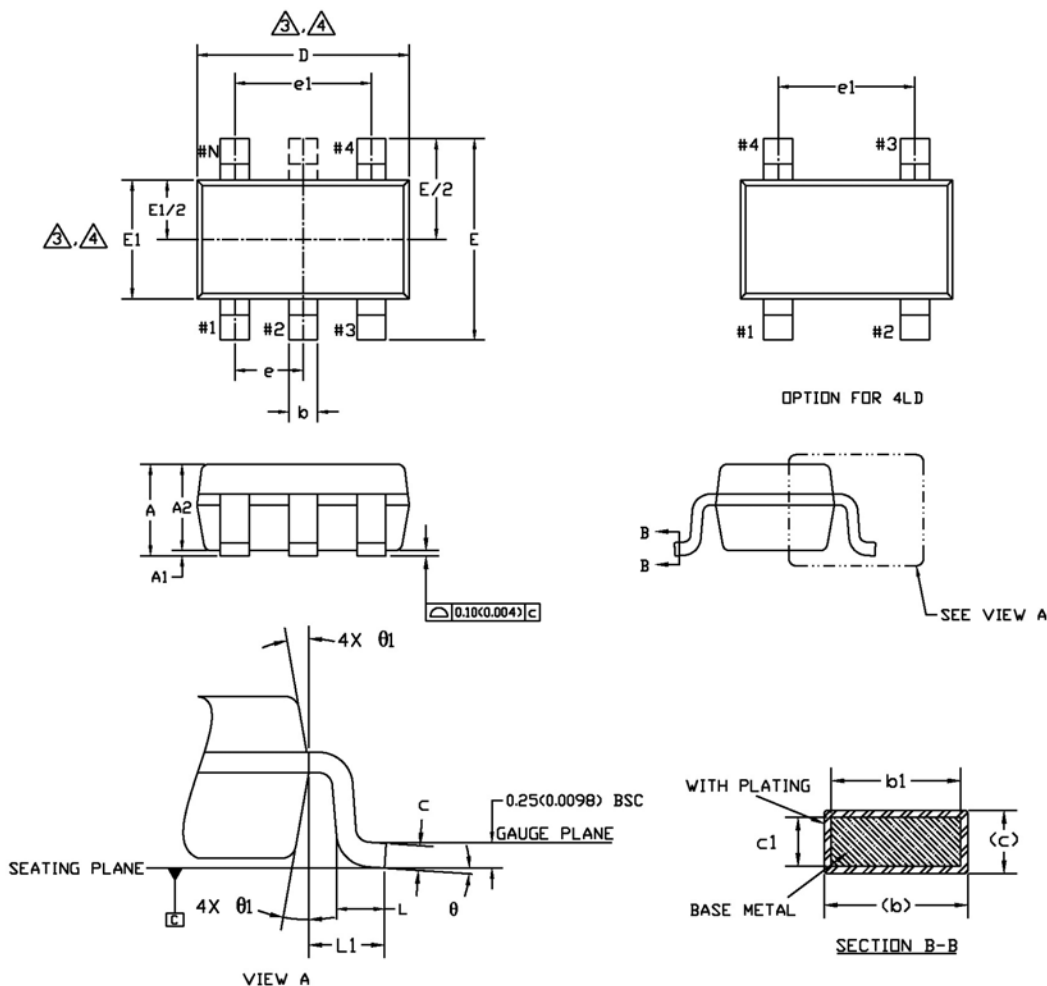

SYMBOL	COMMON					
	DIMENSIONS MILLIMETER			DIMENSIONS INCH		
	MIN.	NDM.	MAX.	MIN.	NDM.	MAX.
A	1.20	1.30	1.40	0.047	0.051	0.055
A1	0.05	-	0.15	0.002	-	0.006
A2	0.90	1.15	1.30	0.035	0.045	0.051
b	0.35	-	0.50	0.013	-	0.020
b1	0.35	0.40	0.45	0.013	0.015	0.017
c	0.08	-	0.22	0.003	-	0.008
c1	0.08	0.13	0.20	0.003	0.005	0.007
D	2.90 BSC			0.114 BSC		
E	2.80 BSC			0.110 BSC		
E1	1.60 BSC			0.062 BSC		
e	0.95 BSC			0.037 BSC		
e1	1.90 BSC			0.074 BSC		
L	0.35	0.45	0.55	0.013	0.017	0.021
L1	0.60 REF.			0.023 REF.		
theta	0°	4°	8°	0°	4°	8°
theta1	10° TYP			10° TYP		

NOTE :

1. Dimensioning and tolerancing per ASME Y 14.5 M - 1994.
2. Dimensions are in millimeters. Converted inch dimension are not necessarily exact.
3. Dimension D does not include mold flash, protrusions or gate burrs. Mold flash, protrusion or gate burrs shall not exceed 0.15 mm per side. Dimension E1 does not include interlead flash or protrusion. Interlead flash or protrusion shall not exceed 0.15 mm per side.
4. Top package may be smaller than the bottom package. Dimension D and E1 are determine at the outermost extremes of the plastic body exclusive of mold flash gate burrs and interlead flash.
5. Terminal numbers are shown for reference only. Die is facing up for molding. Die is facing down for trim/form.

Ordering Information

Device	Operating Tj	Initial TTHRESH	Adjusted TTHRESH	Tol.	PKG Type	Wrap	Ordering Number
LDS297P	-55°C ≤ 150°C	120°C	50-150°C	± 3°C	SOT-23-5	T&R	LDS297GY-M5-AJ-TL

Note: Lead Free and RoHS compliant.

Warranty and Use

LEADIS TECHNOLOGY MAKES NO WARRANTY, REPRESENTATION OR GUARANTEE, EXPRESS OR IMPLIED, REGARDING THE SUITABILITY OF ITS PRODUCTS FOR ANY PARTICULAR PURPOSE, NOR THAT THE USE OF ITS PRODUCTS WILL NOT INFRINGE ITS INTELLECTUAL PROPERTY RIGHTS OR THE RIGHTS OF THIRD PARTIES WITH RESPECT TO ANY PARTICULAR USE OR APPLICATION AND SPECIFICALLY DISCLAIMS ANY AND ALL LIABILITY ARISING OUT OF ANY SUCH USE OR APPLICATION, INCLUDING BUT NOT LIMITED TO, CONSEQUENTIAL OR INCIDENTAL DAMAGES.

Leadis Technology products are not designed, intended, or authorized for use as components in systems intended for surgical implant into the body, or other applications intended to support or sustain life, or for any other application in which the failure of the Leadis Technology product could create a situation where personal injury or death may occur.

Leadis Technology reserves the right to make changes to or discontinue any product or service described herein without notice. Products with data sheets labeled "Advance Information" or "Preliminary" and other products described herein may not be in production or offered for sale.

Leadis Technology advises customers to obtain the current version of the relevant product information before placing orders. Circuit diagrams illustrate typical semiconductor applications and may not be complete.



Leadis Technology
 800 W. California Ave,
 Suite 200
 Sunnyvale, CA 94086
 Phone: 408.331.8600
 Fax: 408.331.8601
<http://www.leadis.com>

Document No: 297LDS
 Revision: 1.4
 Issue date: 5/20/08